

PROJECTS SUPPORTED BY PRIVATE FUNDS

PROJECTS SUPPORTED BY PRIVATE FUNDS IMPLEMENTED BY UPT 2019

Field	Total number of projects	Number of projects presented
Environment	40	3
Exploration and exploitation of the earth	1	-
Transport, telecommunications and other infrastructures	28	1
Education	4	-
Energy	2	-
Industrial production and technology	55*	7**
Social and economic sciences	1	-
Technological and engineering sciences	3	-
Total	134	11

* *National Private Funds: 54 projects;*
International Private Funds: 1 project.

** *National Private Funds: 6 projects;*
International Private Funds: 1 project.

EVOLUTION OF PROJECTS SUPPORTED BY PRIVATE FUNDS CONTRACTED BY UPT 2015 - 2019

A series of inter-institutional collaborations have crucially influenced UPT's ranking classification exercise between 2015 and 2019.

Two main categories of institutional collaborations are to be noted: inter-university collaborations and collaborations with enterprises. Each of them has clearly established, mutually-shared objectives: mutual support, know-how transfer, and cooperation objectives for a common output.

UPT has always maintained a close relationship with the community, with the external environment, this relationship being its own reason to exist. Beyond the actual research and formal education, the research accomplished through technological transfer has been a constant concern for the University departments, faculties and management structures, which is reflected in the number of contracts with private companies.

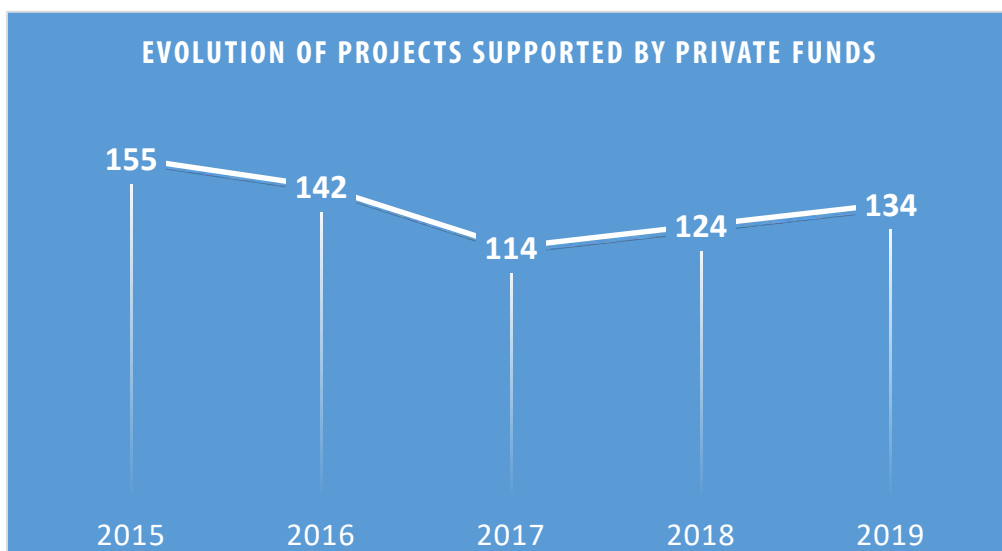

This chapter presents a selection of the research contracts with third parties.

RESEARCH IN THE DEVELOPMENT AND IMPROVEMENT OF AUTOMATED TESTING SYSTEMS USING LABVIEW, LABWINDOWS/CVI AND TESTSTAND

Goal of the project

Carrying out project execution services entitled "Research in the Development and Improvement of Automated Testing Systems using LabVIEW, LabWindows/CVI and TestStand". Technical consultancy activity in the field of automated testing systems.

Short description of the project

Design, development of automated testing systems.

Implementation period

15.03.2019 – 15.07.2019

Main activities

The following were achieved:

- automatic testing programs;
- programs, which were based on event scheduling;
- handling program errors;
- graphical interfaces for automatic testing programs of electronic circuits;
- programming of DAQmx type acquisition boards;
- programming of test equipment on different communication interfaces;
- distribution of the application by generating installation packages.

Results

- New programming techniques have been implemented for testing electronic circuits and programmable measurement and control equipment has been interfaced with computer systems.
- Threads have been implemented for automated testing programs and multi-core programming for testing systems has also been achieved.
- New automated testing techniques were used, such as: boundary scan, ICT and functional testing.

Applicability and transferability of the results

The results are used in the Honeywell Life Safety Romania S.R.L. plant from Lugoj, Timis country, Romania.

All the test systems and test programs are implemented and used for testing many electric circuits fabricated in the plant.

Research Centre

Programmable Logic Systems Research Laboratory supported by National Instruments & Honeywell Life Safety Romania S.R.L.

Financed through/by

Honeywell Life Safety Romania S.R.L.

Research team

Roland SZABO, PhD
Prof. Mihaela LASCU, PhD

Contact information

Roland SZABO, PhD
Faculty of Electronics Telecommunications and Information Technologies/Applied Electronics Department & Measurements and Optical Electronics Department, Address: Vasile Parvan Av., No. 2, Postal Code 300223, Timisoara
Phone: (+40) 256 403 351
E-mail: roland.szabo@upt.ro
Web: <https://sites.google.com/view/rolandszabo>

EXTENDING THE FLYING PROBE MEASUREMENT CAPABILITIES BY EXTERNAL LCR METER INTEGRATION

Goal of the project

The goal of this project was to implement a flexible solution to integrate, at software and hardware, level the Takaya Flying Probe (FP) type equipment and the LCR meter. By this solution, we aimed at extending the measurement range and improving the accuracy of the FP, in the process of evaluating circuit-mounted inductive and capacitive components.

Short description of the project

The goal of this application is to avoid the apparition of FP erroneous measurement results, for circuit-mounted L and C components, by integration of an LCR meter with the FP. This application was implemented with the help of a partner company which provided the required equipment: the Takaya APT 1400F FP and the BK Precision 891 LCR meter.

Implementation period

01.04.2019–31.12.2019

Main activities

- A study on the communication possibilities between the Takaya APT, LCR meter and external applications using Dynamic Data Exchange (DDE) technology;
- Automatic determination of the best conditions for measuring L-C components, by automatic analysis of the frequency response;
- Development of the integrated software for repetitive measurements;
- Testing experimental models in the industrial area to evaluate the repeatability and measurement accuracy of the proposed solution.

Results

- The integration of the LCR meter device can be performed transparently, without complex user intervention;
- A collection of VI functions, based on DDE, that provide communication between APT and an external device;
- Software for the automatic determination of the best measurement conditions by analyzing the response in the frequency range 1 kHz – 300 kHz;
- Software for automatic measurement of inductive and capacitive parameters;
- Part of the experimental results have been published in an ISI indexed Journal: R. Ionel, S. Mischie, D. Belega, L. Mătiu-lovan, C. Dughir, I&M Applications for Educational Purposes, IEEE Instrumentation & Measurement Magazine, April, 2020.

Applicability and transferability of the results

With the redevelopment of the urban section of the watercourse, it is possible to exploit this non-polluting energy resource in order to satisfy a part of the public consumption. For the moment, the technical part of the study was disseminated through a scientific paper published in the specialized journal Hidraulica Bucharest (ISSN 1453-7303).

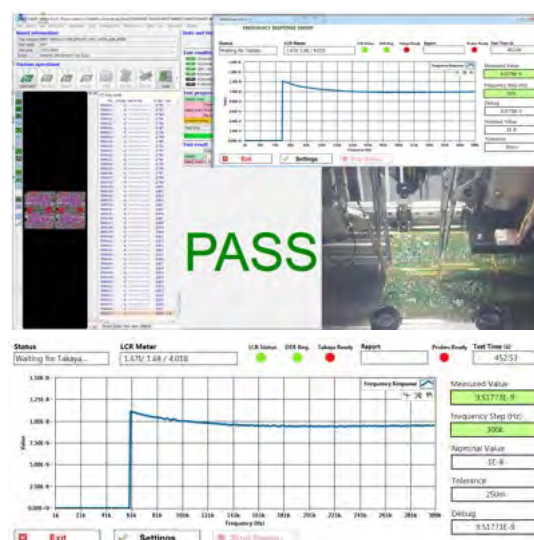

Financed through/by

S.C. Alfa Test S.R.L., Timișoara

Research team

Lecturer Liliana MĂȚIU-IOVA, PhD
Lecturer Raul Ciprian IONEL, PhD
Adina Elena IVONICIU

Contact information

Lecturer Eng. Liliana MĂȚIU-IOVAN, PhD
Faculty of Electronics, Telecommunications and Informational Technologies, Department of Measurements and Optical Electronics
Address: Room B329, 3rd Floor, Bd. Vasile Parvan, nr. 2, 300223 Timisoara, Romania
Phone: (+40) 256 403367 Mobile: (+40) 722307996
E-mail: liliana.matiu-iovan@upt.ro Web: meo.etc.upt.ro

RESEARCH ON ADVANCED INTEGRATION BETWEEN THE TERADYNE TSA N129 TEST STATION AND THE VECTOR CANCase XL DEVICE

Goal of the project

The goal of this project was to implement a functional technical approach related to an integration between the Vector CAN Case XL (CCXL) module and the Teradyne In Circuit Tester (ICT). The proposed application is the achievement of a collaboration between two industrial partners: Continental Automotive Romania (Timișoara Plant) and Alfa Test S.R.L. The need for such an integration has originated in the context of permanent focus on innovative production solutions.

Short description of the project

The capabilities offered by this solution include: communication protocol administration, automated formatting of CAN messages, CAN segmentation, selection information embedded in exchanged frames or the combination of ICT based measurements interposed between CAN dialogs.

Implementation period

01.04.2018 - 31.03.2019

Main activities

- Activity 1: A study on the communication possibilities between the Teradyne In Circuit Tester equipment and external hardware tools, using dedicated DLL files.
- Activity 2: Preliminary communication implementations between the Teradyne In Circuit Tester equipment and external hardware tools, using dedicated DLL files.
- Activity 3: Testing the communication library and extending the available commands set. The results should be a 90% minimal success rate for transferring the CAN frames between the Vector tools and the ICT software.

- The Teradyne Test Station Multi Site (1)
- Two CCXL network interfaces have been placed inside the back chassis; Test Fixture (2);
- DUTs (3);
- ICT monitors (4).



Financed through/by

S.C. Alfa Test S.R.L., Timișoara

Results

- over 130 CAN telegrams/responses and can be used for testing other products;
- average response time of 0.56s/CAN command (TS send cmd, TS receive rsp);
- Automated repetition in case of FAIL responses (3 times);
- First Pass Yield (FPY) = 98%, 51 consecutive runs, average test time is 97 s, over 320 CAN command/response exchanges for each test, experimental context;
- approximately 25000 DUTs/month tested with this solution;
- best FPY average over 2 months 96%, worst case FPY average over 2 months 79%. These results are a combined result, with pure ICT test;
- average test time/DUT is 107s.

Applicability and transferability of the results

The solution is running in production, it includes over 100 CAN telegrams/responses and can be used for testing other products. An average response time for a single CAN telegram, from the moment it is issued by the Teradyne Test Station until the user receives the result on the Test Station interface is approximately 0.56 s. A 2.22 s execution time has been obtained for a frequency measurement test which includes 3 type of CAN telegrams.

The proposed application has been developed in the context of creating innovative test solutions which correspond to the requirements of one of the most important automotive companies worldwide.

Research team

Assist. Prof. Raul Ciprian IONEL, PhD
Assist. Prof. Liliana MĂȚIU-IOVA, PhD

Contact information

Assist. Prof. Raul Ciprian IONEL, PhD
Faculty of Electronics, Telecommunications and Informational Technologies, Department of Measurements and Optical Electronics
Address: Room B326, 3rd Floor, Bd. Vasile Parvan, nr. 2, 300223 Timișoara, Romania
Phone: (+40) 256403366, Mobile: (+40) 723619912
E-mail: raul.ionel@upt.ro
Web: <https://ieeexplore.ieee.org/document/8583920>

TECHNICAL-SCIENTIFIC ANALYSIS REGARDING THE POSSIBILITY OF FUEL AND NOXES REDUCTION OF DIESEL ENGINES THAT EQUIPP S.C. SANGO WATER CO S.A. PERSONS TRANSPORT VEHICLES

Goal of the project

The aim of the project is to identify the technical solutions that can be implemented on a target group of vehicles in order to reduce the fuel consumption as well as the emissions exhausted during their operating regimes.

Short description of the project

Within the project, the fuel consumption of a group of vehicles was analyzed based on pollution standards and real operating conditions.

Implementation period

01.10.2019–24.05.2020

Project implemented by

The project will be implemented by S.C. Sango Water Co S.A.

Main activities

- Identification of real test conditions.
- Determining the fuel consumption for the buses in the target group.
- Measurement and verification of results.

Results

- The factors that lead to a reduction in fuel consumption at a target group of buses were identified
- Technical solutions for optimizing fuel consumption have been proposed.

Applicability and transferability of the results

- The obtained results led to the identification of technical solutions to reduce fuel consumption, and implicitly, the pollution degree, so that the emission values to fall within the limits imposed by pollution standards.

Financed through/by

S.C. SANGO WATER Co S.A.

Research Centre

Research Centre for Thermal Machines and Equipments, Transportation and Environmental Pollution Control,

Research team

- Daniel OSTOIA,
- Arina Negoitescu,
- Adriana Tokar,
- Dan Negoitescu,
- Ion Silviu Borozan,
- Dan Tokar

Contact information

Prof. Daniel OSTOIA, PhD
Faculty for Mechanical Engineering
Research Centre for Thermal Machines and Equipments,
Transportation and Environmental Pollution Control,
Address: Mihai Viteazu No. 1, Postal Code 30222, Timisoara, Romania
Phone: (+40) 256 403672
Mobile: (+40) 722827957
E-mail: daniel.ostoia@upt.ro

POLLUTANT EMISSION MONITORING OF DIFFERENT INDUSTRIAL EQUIPMENTS & TECHNOLOGICAL UNITS, ACCORDING CONTRACTS WITH DIVERSE ECONOMIC AGENTS, BASED ON THE RENAR ACREDITATION OF THE LACIEDIN LAB OF UPT

Goal of the project

- Goal of all cooperation contracts is to identify the ecological performances of different technological processes and units, based on emission monitoring of species such as: NO_x, CO, SO₂, particles, VOC, CO₂, in addition O₂ and physical parameters control.
- The LACIEDIN laboratory, as unique university laboratory for air quality monitoring in the region, offers support to detect potential polluting sources and elaborates diverse technical bulletins, according the measurements.
- Main clients of our lab are indicated in the followings: SC CENTRALA ELECTRICA DE TERMOFICARE HIDROCARBURI S.A. ARAD; COMBINATUL AGROINDUSTRIAL OLARI; SPUMOTIM S.A. TIMISOARA; FRIGOGLASS SRL PARTA, SC ELBA SA TIMISOARA, SC PORKPROD IRATOSU, CASADEVALL ROMANIA SRL, VOESTALPINE ROTEC COATING SRL, UTTIMISOARA, PLASESS ROMANIA SRL CHISODA, KIMBALL ELECTRONICS ROMANIA SRL REMETEA MARE, SMART WOOD ROMANIA SRL TIMISOARA, and others.
- One expresses respect & appreciation for all industrial partners, and thank for the opportunity to serve their interest.

Short description of the project

TESTS: 1. Specific tests for identification of the concentration of specific gaseous and solid pollutants, according legislation and standard methods,

2. Physical tests.

SCOPE: 1. Determination of the potential polluting effect of specific technologies and industrial units

2. Development of the laboratory

Implementation period

The periods are indicated in the different contracts signed by UPT. They cover long term cooperation.

Project implemented by

LACIEDIN of UPT (Laboratory for Fuel Analysis, Ecological Investigation and pollutants' Dispersion of the Politehnica University of Timisoara) www.mediu.ro is fully implementing standard 17025/2018.

Main activities

- Preparation of the measuring points (measuring plan) and identification of representative technological regimes
- Calibration of the instruments
- Measurements and verification of the results
- Calculations & Conceiving the report (Technical Bulletin) in accordance with the RENAR specifications

Results

- Technical Bulletins elaborated are attesting the level of pollution of different sources



Applicability and transferability of the results

- Development of a strategy of monitoring, according to the specific needs of the client and support for future developments.
- Raising the visibility of UPT on the free market concerning the collaboration with industrial units.
- Offering to our students of a possibility to be part of the research activity of the teachers.
- Offering to the members of the team a modality to perform, also in industrial cooperation, in addition to the main duties as researcher or university teacher.
- Maintaining the standards & quality for RENAR accreditation.
- Developing skills and knowhow for all personnel involved, including students.



Financed through/by

- diverse frame contracts: BC16/ 25.02.2019; BC36/09.04.2019; BC 78/26.07.2019; BC 79/29.07.2019; BC 82/31.07.2019; BC 101/04.10.2019; BC62/10.06.2019; BC65/18.06.2019, BC 125/09.12.2019; BC120/05.12.2019; BC 121/05.12.2019, BC 33/20.03.2015, and few more.

Research Centre

Research Centre for Thermal Machines and Equipments, Transportation and Environmental Pollution Control, http://www.upt.ro/Informatii_-research-centre-for-thermal-machines-and-equipments-transpo_109_en.html

Through the RENAR accredited laboratory LACIEDIN www.mediu.ro



Research team

Ioana IONEL
Ramon Mihai Balogh
Delia Gabriela TRIF TORDAI
Daniel BISORCA
Virgil STOICA
Gabriela NAGY
Gavril BRATEANU

Contact information

Prof. Ioana IONEL, PhD
Faculty for Mechanical Engineering/ LACIEDIN in the Research Centre for Thermal Machines and Equipments, Transportation and Environmental Pollution Control,
Mihai Viteazu No. 1, Postal Code 30222, Timisoara, Romania
Phone: (+40) 256 403670
Mobile: (+40) 723349337
E-mail: ioana.ionel@upt.ro
Web: www.mediu.ro

AIR QUALITY MONITORING IN DIFFERENT LOCATIONS, ACCORDING CONTRACTS WITH DIVERSE ECONOMIC UNITS, BASED ON THE RENAR ACREDITATION OF THE LACIEDIN LAB

Goal of the project

- Goal of all cooperation contracts is to focus on the potential pollution episodes. The air quality has a huge importance for the health of the population, as well the environment, in general, and assures the quality of life as well.
- The LACIEDIN laboratory, as unique university laboratory for air quality monitoring in the region, offers, long term measurements' campaigns, that are absolute necessary to attest the quality of air in the region. It measures: CO, NOx, VOC's, particles, O3, benzene, etc. The goal of the projects is to offer a data base concerning air quality and specific other information, attested by a RENAR qualified laboratory.
- main clients of our lab are indicated in the followings: SC CENTRALA ELECTRICA DE TERMOFICARE HIDROCARBURI S.A. ARAD; INSTITUTUL NATIONAL DE CERCETARE DEZVOLTARE PENTRU ENERGIE - ICEMENERG BUCURESTI (as subcontractor for RETEAUA ELECTRICA DE TRANSPORT LEA - ST TIMISOARA); COMBINATUL AGROINDUSTRIAL OLARI; COMSA SA BARCELONA - SUCURSALA BUCURESTI; SPUMOTIM S.A. TIMISOARA; FRIGOGLOSS SRL PARTA, SC PORKPROD IRATOSU, STERICYCLE ROMANIA SRL, and others.
- One expresses respect & appreciation for all industrial partners, and thank for the opportunity to serve their interest.

Short description of the project

TESTS according legislation and standard methods:

1. Gravimetric tests (dust) affecting air quality,
2. Specific tests for specific gaseous pollutants in air,
3. Physical tests.

- SCOPE:
1. Determination of air quality in different regions –rural or urban & industrial sites
 2. Identification of potential impact of several pollutants upon the air quality and future strategies

Implementation period

The periods are indicated in the different contracts signed by UPT. They cover long term cooperation.

Project implemented by

LACIEDIN of UPT (Laboratory for Fuel Analysis, Ecological Investigation and pollutants' Dispersion of the Politehnica University of Timisoara) www.mediu.ro is fully implementing standard 17025/2018.

Main activities

- Identification of the most representative regimes for measuring
- Identification of the safety conditions for the workers
- Preparation of the measuring points (measuring plan)
- Calibration of the instruments
- Measurements and verification of the results
- Calculations
- Conceiving the report (Technical Bulletin) in accordance with the RENAR specifications.

Results

- Technical Bulletins elaborated are attesting the level of pollution in the areas, and generally can be used to inform the population as well, if the client is giving its approval..



Applicability and transferability of the results

- Development of a strategy of monitoring, according to the specific needs of the client.
- Raising the visibility of UPT on the free market concerning the collaboration with industrial units.
- Offering to our students of a possibility to analyse real pollution episodes and develop information based on own experience.
- Offering to the members of the team a modality to perform, also in industrial cooperation, in addition to the main duties as researcher or university teacher.
- Maintaining the quality for next RENAR accreditation.
- Developing skills and knowhow for all personnel involved, including students.



Financed through/by

- Diverse frame contracts such as: BC16/ 25.02.2019; BC36/09.04.2019; BC 78/26.07.2019; BC 79/29.07.2019; BC 82/31.07.2019; BC 101/04.10.2019, BC 26/ 21.03.2019 and few more.

Research Centre

Research Centre for Thermal Machines and Equipments, Transportation and Environmental Pollution Control, http://www.upt.ro/Informatii_-research-centre-for-thermal-machines-and-equipments-transpo_109_en.html

Through the RENAR accredited laboratory LACIEDIN www.mediu.ro

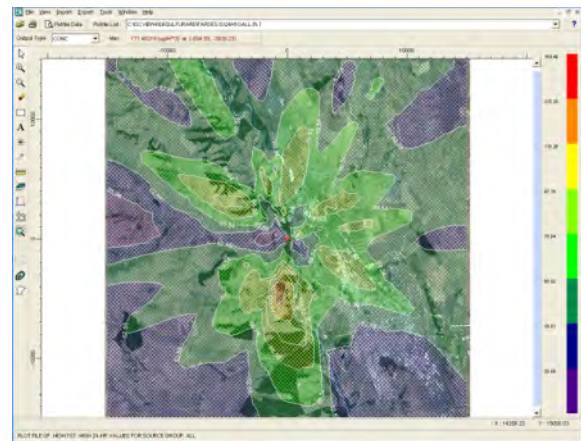

Research team

Ioana IONEL
Ramon Mihai Balogh
Delia Gabriela TRIF TORDAI
Daniel BISORCA
Virgil STOICA
Gabriela NAGY
Gavril BRATEANU

Contact information

Prof. Ioana IONEL, PhD
Faculty for Mechanical Engineering/ LACIEDIN in the Research Centre for Thermal Machines and Equipments, Transportation and Environmental Pollution Control,
Mihai Viteazu No. 1, Postal Code 30222, Timisoara, Romania
Phone: (+40) 256 403670
Mobile: (+40) 723349337
E-mail: ioana.ionel@upt.ro
Web: www.mediu.ro

COMPLEX MEASUREMENTS FOR THE DETERMINATION OF POLLUTANT EMISSIONS AT THE TIMISOARA (16 MĂCIN STR.), ORAVIȚA, LUPENI AND MARGHITA UNITS OF THE COMPANY TRW AUTOMOTIVE SAFETY SYSTEMS

Goal of the project

Identifying the level of pollution generated by specific units in the company. Thus, by analyzing the results, the specialists from TRW Automotive Safety Systems can adapt and reconsider their technologies, in order to optimize/ reduce the emissions' levels/concentrations, if they are not appropriate and in correlation with the emission control legislation.

Thus the company can maintain its leading position in the frame of all Romanian production companies, knowing that TRW Automotive Safety Systems gained by 2018 the third place for cooperation in Romania (diploma offered by ListaFirme.ro, 2018).

Short description of the project

TESTS:

- 1.Gravimetric tests (dust) (emissions);
- 2.Electrochemical tests;
- 3.Flame ionization tests;
- 4.Physical tests.

SCOPE:

1. Determination of total dusts (emissions).
2. Determination of combustion gas concentrations (O₂, CO, CO₂, H₂S, SO₂ and CH₄)
3. Determination with flame ionization detector of COV / COT.
4. Determination of physical parameters (pressure, speed and flow).

FEEDBACK:

The client is offering a feedback by filling in a specific file, that enables us to improve the offer and cooperation activity for the future.

Implementation period

Starting 15.04.2019, up to 24 months, with potential prolonging of the cooperation availability of the contract, at request

Project implemented by

- LACIEDIN of UPT (Laboratory for Fuel Analysis, Ecological Investigation and pollutants' Dispersion of the Politehnica University of Timisoara) www.mediu.ro
- The LAB is profound anchored in the reality of the present society and devoted to the protection of the environment. Through the product offered it assists and helps all the clients greatly to prevent and combat the specific pollution level resulted from their production. LACIEDIN is fully implementing standard 17025/2018.

Main activities

- Identification of the most representative regimes for measuring
- Identification of the safety conditions for the workers
- Preparation of the measuring points (measuring plan)
- Calibration of the instruments
- Measurements and verification of the results
- Calculations
- Conceiving the report (Technical Bulletin) in accordance with the RENAR specifications



Results

Technical Bulletins attesting the level of pollution exhausted by diverse facilities, as identified by the Agency of Environmental protection as to be monitored on specific intervals, during representative technological episodes.

Applicability and transferability of the results

- Development of a strategy of monitoring, according to the specific needs of the client.
- Raising the visibility of UPT on the free market concerning the collaboration with industrial units.
- Offering to the members of the team a modality to perform, also in industrial cooperation, in addition to the main duties as researcher or university teacher.
- Maintaining the quality according to existing RENAR accreditation.
- Developing skills and knowhow for all personnel involved.
- Supporting practical development for the students and correlation of research with theory.



Research Centre

Research Centre for Thermal Machines and Equipments, Transportation and Environmental Pollution Control, http://www.upt.ro/Informatii_-research-centre-for-thermal-machines-and-equipments-transpo_109_en.html
Through the RENAR accredited laboratory LACIEDIN www.mediu.ro

Financed through/by

- Contract BC 40/12.04.2019 signed by UPT with TRW Automotive Safety Systems

Research team

Ioana IONEL
Ramon Mihai Balogh
Delia Gabriela TRIF TORDAI
Daniel BISORCA
Virgil STOICA
Gabriela NAGY
Gavril BRATEANU

Contact information

Prof. Ioana IONEL, PhD
Faculty for Mechanical Engineering/ LACIEDIN in the Research Centre for Thermal Machines and Equipments, Transportation and Environmental Pollution Control,
Mihai Viteazu No. 1, Postal Code 30222, Timisoara, Romania
Phone: (+40) 256 403670
Mobile: (+40) 723349337
E-mail: ioana.ionel@upt.ro
Web: www.mediu.ro

STUDY FOR SMALL HYDROPOWER PLANTS ON BÂRZAVA RIVER, AS LOCALLY ADAPTED SOLUTION FOR INVESTMENT IN RENEWABLE ENERGY AND PUBLIC UTILITIES INFRASTRUCTURE

Goal of the project

The study is mainly concerned by the implementation of extension of the water supply and the domestic sewerage network for the area of tourist resorts of local interest Secu, Reșița municipality, construction of non-motorized pedestrian and bicycle track to the Secu resort area and providing a protective tube for the electrical cables, lighting, internet, telephony, etc., for the Secu station area.

Short description of the project

Following analysis, the project identifies two accomplishment scenarios from which the technical-economical optimum solution for the extension of the water supply and the domestic sewerage network and the construction of non-motorized track for the Secu tourist resort area.

Implementation period

2019–2020 (19 months)

Financed through/by

Resita Municipality

Main activities

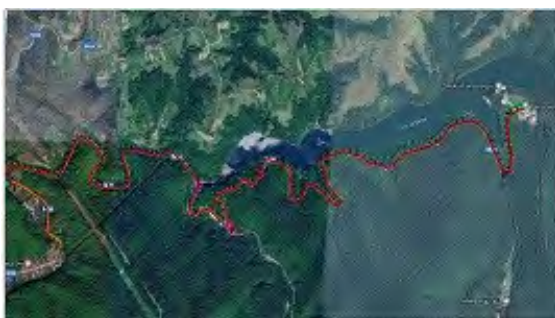

The extension of the drinking water supply network of the objective will be made of PE-HD, PE100, PN16, with De 180 mm, on a length of approximately $L = 7,469$ m. 2 tanks with the volume of $V = 200$ m³ each will be provided, a pumping station for the tank R1 and a pumping station for the tank R2.

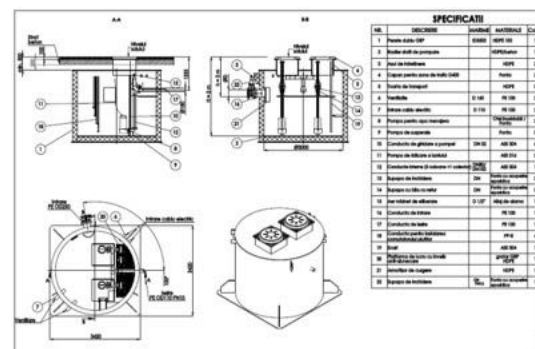

The extension of the sewerage network of the objective implies:

- wastewater discharge pipe from PE-HD, PE100, PN10, with De 200 x 11.9 mm in length of 3,903 m from the wastewater pumping station at the highest point on the route;

- wastewater discharge pipe from PE-HD, PE100, PN16, with 180 x 16.4 mm in length of 4,170 m from the highest point on the route to the existing manhole on Rozelor Street.

On the location of the track bikes, according to the situation plan and the transversal profile, a corrugated protection tube made of PE-HD with De 110 mm is positioned for the protection of the existing or future cables of telephony, electrical, internet, lighting, etc. The total length of the protection tube is 7,394 m.

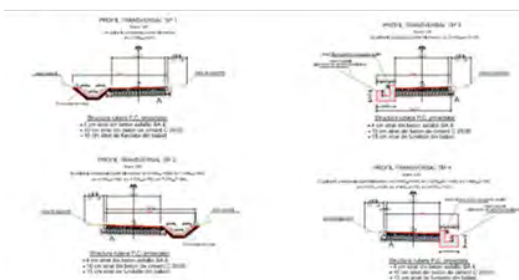
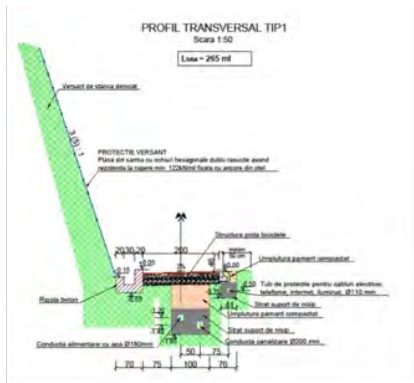

- The projected route of the runway runs over a length of 7,394 m, on the administrative territory of Reșița municipality, Caraș-Severin county.
- It serves the inhabitants of the area as well as the tourists who generate the bicycle traffic in the area.

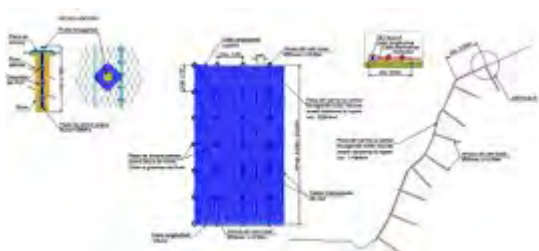

On the projected water-canal route, respectively the bicycle track, in the areas where the existing road is close to the slope, given the width of the bicycle track, respectively of the imposed safety zones, including gutters, demolition works are required in the slope, the total length (cumulated by sectors) being about 1,625 m.

Results

Ensuring the traffic of tourists by bicycle and the degree of comfort in the tourist resort Secu through the water and sewerage system.

Applicability and transferability of the results

Providing a water supply and sewerage system for the Secu tourist resort and the bicycle track for tourists.

Research team

Albert Titus CONSTANTIN,
Constantin FLORESCU,
Ion MIREL,
Marin MARIN,
Ioan ȘUMĂLAN,
Ciprian COSTESCU,
Cristian STĂNILOIU,
Serban –Vlad NICOARA,
Alina POPESCU – BUSAN,
Mircea VIȘESCU, Marius ADAM,
Dan PÎRVULESCU,
Ioana-Alina CREȚAN,
Liliana COTOARBĂ

Contact information

Assist. Prof. Albert Titus CONSTANTIN, PhD
Faculty of Civil Engineering
Department of Hydrotechnical Engineering
Address: 1A George Enescu Street, 300022, Timișoara, Romania
Phone: (+40) 256 404091
Mobile: +40 720 059 371
E-mail: albert.constantin@upt.ro
<https://www.ct.upt.ro/en/hidro/index.htm>

CONSULTING FOR THE USAGE OF MACHINE LEARNING FOR MACHINE VISION APPLICATIONS

Goal of the project

Machine learning consists of scientific study of algorithms and statistical models that computer systems use to effectively perform a specific task. Machine learning algorithms are used in a wide variety of applications (as computer vision is) where it is infeasible to develop an algorithm of specific instructions. Data mining is a field within machine learning, and focuses on exploratory data analysis through unsupervised learning. In its application across business problems, machine learning is also referred to as predictive analytics.

EVT has developed machine vision products, which not only allow precise and error-free image processing, but also products, which are one step ahead of the market. The machine vision software EyeVision by EVT is a product, which due to easy-handling is able to adopt to various applications. The research trends for it follow to enhance easy programming, easy-handling, versatility, extensibility and to get fast solutions.

Short description of the project

EyeVision is a complete image processing package for every possible field of application. EyeVision is connecting a powerful, hardware platform independent software for Windows and Linux with a wide range of hardware for image capture and digital I/O.

All industrial inspection tasks are done fast and effective by the all-in-one image processing software EyeVision.

Implementation period

01.04.2018 - 01.04.2020

Main activities

- Image Processing largely involves several processes to gain information from source data, such as for example image recognition and pattern matching. With the usual methods for image processing one can for example count objects, measure, inspect or read coded information. Image processing nowadays is used in nearly every science and engineering disciplines. One domain for image processing is the quality control at production processes such as automotive engineering, electrical and semiconductor industries, food industry and pharmaceutical industry.
- We focused on research and development of the hardware platform independent software for Windows and Linux - technical. We offer consultancy in the field of all-in-one image processing software.
- Consulting services for using applications at Machine Learning for Machine Vision.

Results

- Machine Vision Software for VisionSensors, SmartCameras and PC Systems - EyeVision the one software for all Hardware Platforms.
- For programmers a PlugIn Interface was made, which supports easy to integrate software modules.
- The software supports all major interfaces for cameras e.g. USB, FireWire, GigE, CL, CoaXPress and analog.

Applicability and transferability of the results

- A build in WebServer for easy remote control as well as interfaces to SAP Oracle and SQL.
- EyeVision Software is available.

Financed through/by

EVT Eye Vision Technology GmbH, Karlsruhe Germany

Research team

Prof. Ivan BOGDANOV, PhD

Contact information

Prof. Ivan BOGDANOV, PhD
Faculty of Electronics, Telecommunications and Information Technology
Department of Applied Electronics
Address: Bvd. Vasile Parvan, No.2, 300223, Timisoara
Phone: (+40) 256 403 338
E-mail: ivan.bogdanov@upt.ro

SOFTWARE MODULE FOR THE ENERGETIC ASSESSMENT OF HYDRAULIC GENERATORS OPERATION IN AQUATIM'S DRINKING WATER SYSTEM

Goal of the project

The goal of the project was to create a simple to use software system validated by experimental results for the quick assessment and monitoring of the efficiency of hydraulic generators deployed in Aquatim's Drinking Water System.

Short description of the project

The project contained three phases:

Phase 1 27.03.2018 – 30.06.2018, for the development of the algorithms for constant-speed pump efficiency assessment and variable-speed pump efficiency assessment.

Phase 2 01.07.2018 – 30.09.2018, for the validation and testing of the software module against laboratory experimental data from a variable-speed pump.

Phase 3 01.10.2018 – 27.12.2018, for the development of the graphical user interface for the central desktop system and for the mobile, smartphone application.

Main activities

- The development of a software module for the energetic assessment of hydraulic generators operation in Aquatim's Drinking Water System in two parts: the desktop application and the smartphone application.
- All software results have been validated with in situ and laboratory experiments for constant-speed pumps and for variable-speed pumps.



Results

An interdisciplinary expert software solution for the energetic assessment of hydraulic generators operation in Aquatim's Drinking Water System in two parts: two desktop applications and the smartphone application.

The desktop applications generate QR code stickers for each hydraulic generator configuration for constant-speed pumps and for variable-speed pumps.

The QR codes are scanned by the mobile application which works both for constant-speed pumps and variable-speed pumps. The hydraulic route is encoded in the QR codes in addition to polynomial curve fitting coefficients, in order to allow the correct assessment of the efficiency for each pump configuration.

Applicability and transferability of the results

- The results are tailored for the energetic assessment of hydraulic generators operation in Aquatim's drinking water system.



Implementation period

23.02.2018-22.02.2019

Financed through/by

AQUATIM S.A.

Research Centre

Research Center in Computer and Information Technology (CCCTI)

Research team

Assist. Prof. Alin-Adrian ANTON, PhD
Eng. Daniel Calin MOS, PhD Student
CS1 Sebastian MUNTEAN, PhD

Contact information

Assistant Prof. Alin-Adrian ANTON, PhD
Faculty of Automation and Computers
Department of Computer and Information Technology
Address: BvdI. Vasile Parvan no.2. 300223, Timisoara
Phone: (+40) 256 403 281
Mobile: (+40) 745 001010
E-mail: alin.anton@cs.upt.ro
Web: <http://staff.cs.upt.ro/~alin.anton>

PROTOTYPE RESEARCH AND DEVELOPMENT FOR IMAGE PROCESSING SOLUTION FOR BOARDS TESTING IN THE AUTOMOTIVE INDUSTRY

Goal of the project

The main goal of the project is to obtain a prototype, able to execute boards inspection, based on image processing, functioning in accordance with the company requirements for the production line.

Short description of the project

The starting point of the project was represented by an experimental model. The activities were to adapt, to improve, to test and to validate the software from the experimental model within a new mechanical-hardware structure in order to obtain a prototype that is able to perform ECU tests based on image processing functioning in accordance to the Hella company requirements in the production line.

Implementation period

22/11/2018-22/03/2019

Main activities

The prototype was conceived and implemented, and the solution was integrated, tested and validated in the production line.

Results

Some results are detailed below:

- 1) Starting from the experimental model (consisting of 4 compact modules, each containing a Raspberry Pi and a camera), the solution was modified within the prototype in order to fit the high number of different ECUs from the production line and to reach the test indicators. A prototype solution was conceived and implemented, based on 6 Raspberry Pis and 6 cameras, this time physically separated, and improving the quality of the inspection for the connectors with perspective issues. Having separated cameras, the prototype allows besides higher possibilities to eliminate the perspective, a higher luminosity on the ECUs analyzed surface.
- 2) The capability to vehiculate data between 1 master and 5 slaves, including from request/response transmissions toward data aggregation, concluding procedures and reporting.
- 3) A generic platform was created for n processing modules. Therefore now, the prototype contains only two branches: 1 master branch and 1 slave branch, and the software from the slaves is generic for any Raspberry Pi slave in the scheme.
- 4) The prototype solution is extended to function for the 4 main classes of ECUs from the production line. The extension required a whole new concept for the software module.
- 5) Modules were conceived and developed to include layouts from all main classes of boards and all the particular sets of boards inside the main classes.

- 6) The pin search module was optimized to reduce the search area and the processing times.
- 7) New detection modules were researched and implemented based on islands identification, separation and grouping, for more accurate conclusions.
- 8) A new method was researched and developed to establish a dynamic illumination threshold associated to each pin.
- 9) The layout saving, storing and loading was optimized due to the high number of layouts in the production line.
- 10) Detection task request optimizing was researched and implemented mainly in a sense that the master equipment extracts and sends a list of the connectors to analyze for each slave equipment. This procedure eliminates the fix slaves, each being able to be replaced without application issues.
- 11) The processing time was significantly reduced by eliminating the necessity of connector rotation for the slave's software.
- 12) A new module was implemented for new layout learning, placed only on the master equipment. This way no ssh/vnc connection is necessary for each slave.
- 13) A new offset (search area) separation was researched and implemented so that each pin has now its own offset. Also, a new module was created that establishes the filling factor for the offset for each pin.
- 15) The prototype is able to apply all the changes in configuration from the graphical user interface.
- 16) The prototype functions in complete correlation with the traceability software within the company.

Financed through/by

HELLA ROMANIA S.R.L.

Research team

Adrian Stefan KORODI, Ioan SILEA, Alexandru Brian BOITOR
Denis Florin ANITEI, Mariana Daniela GIUCHICI

Contact information

Assistant Prof. Adrian KORODI, PhD
Faculty of Automation and Computers Science
Department of Automation and Applied Informatics
Address: Bd. Vasile Parvan, No. 2, 300223, Timisoara
E-mail: adrian.korodi@upt.ro