

PATENTS

EVOLUTION OF PATENTS UNDER AFFILIATIONS OF UPT 2015 - 2019

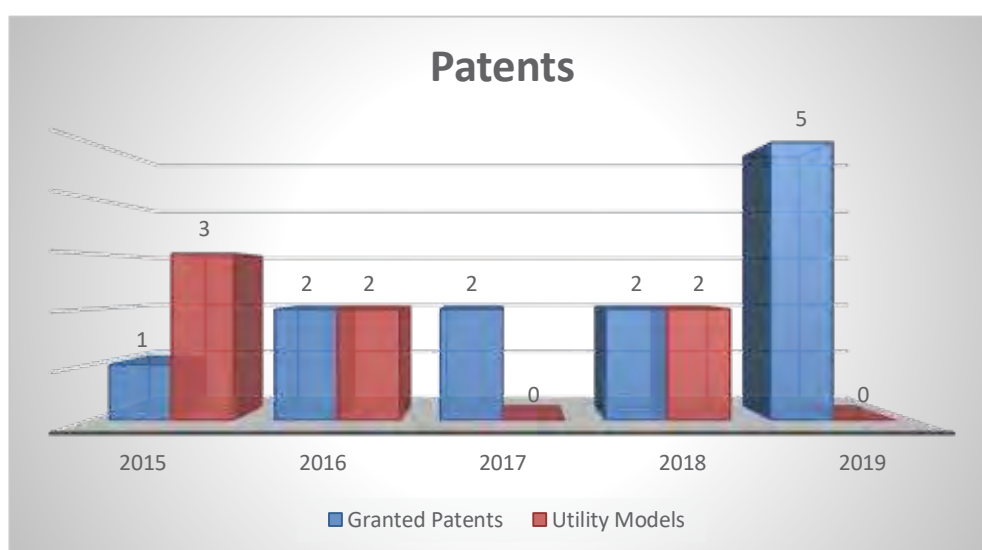

The innovative capacity of the Politehnica University Timisoara is supported by teachers and scientific researchers through patents and utility models invented, presented in this section.

Granted Patents

INVENTORS: MUNTEAN SEBASTIAN, SUSAN-RESIGA ROMEO-FLORIN, BOSIOC ILIE ALIN, CONSTANTIN SORIN RĂZVAN, MAXIM DANIEL IOSIF, TANASA CONSTANTIN, VEKAS LADISLAU-NICOLAE, BORBATH ISTVAN, ANTON LIVIU-EUGEN.

PATENT NO. 131578 / 2019

EQUIPMENT FOR REDUCING CAVITATIONAL EFFECTS AND LEVELING FLOW AT TURBO PUMPS INLET



The invention relates to an equipment for reducing cavitation effects and for leveling the flow at the inlet of turbo-pumps operating at flows different from the flow they were designed for, turbo-pumps which may be used for irrigations, water supply of towns and industrial objectives and for heating systems.

According to the invention, the equipment consists of a pipe (1) which takes over the water from a downstream lake or a well through a suction pipe elbow (3) to a rotor of turbo-pump (5) driven by an electric motor (6) using a shaft (9) and leads it to an accumulator (10) and a discharge pipe (11) for controlling the cavitation and levelling the flow.

It is used the controlled variable speed of an impeller (4) in relation to the constant speed of the shaft (9) of the rotor of the turbo-pump (5) by mounting the impeller (4) coaxial onto a shaft (8) and the shaft (9), the shaft (8) of the impeller (4) and the shaft (9) of the turbo-pump being driven by means of a control device (7) which comprises a magneto-rheological clutch which, by the control of an automation device or an operator, allows the differentiation between the speeds of the impeller (4) and the shaft (9) of the rotor of the turbo-pump (5), the control device (7) consisting of a cylindrical flange (13) fixed onto the output shaft of a driving motor (6), the flange (13) being connected through an elastic coupling (15) to

another semi-cylindrical flange (14), which is fixed onto an iron piece (17) integral with the shaft (9) of the turbo-pump, the shaft (8) of the impeller (4) being in rotary motion on ball bearings inside the borehole thereof, while, between the shafts (8 and 9) a mechanical coupling is provided by means of a magneto-rheological fluid (16) the viscosity of which may be controlled and adjusted by the size of the magnetic field directed by a mechanism or an operator, which is transmitted to an electromagnet (18) by means of a slip ring (19).

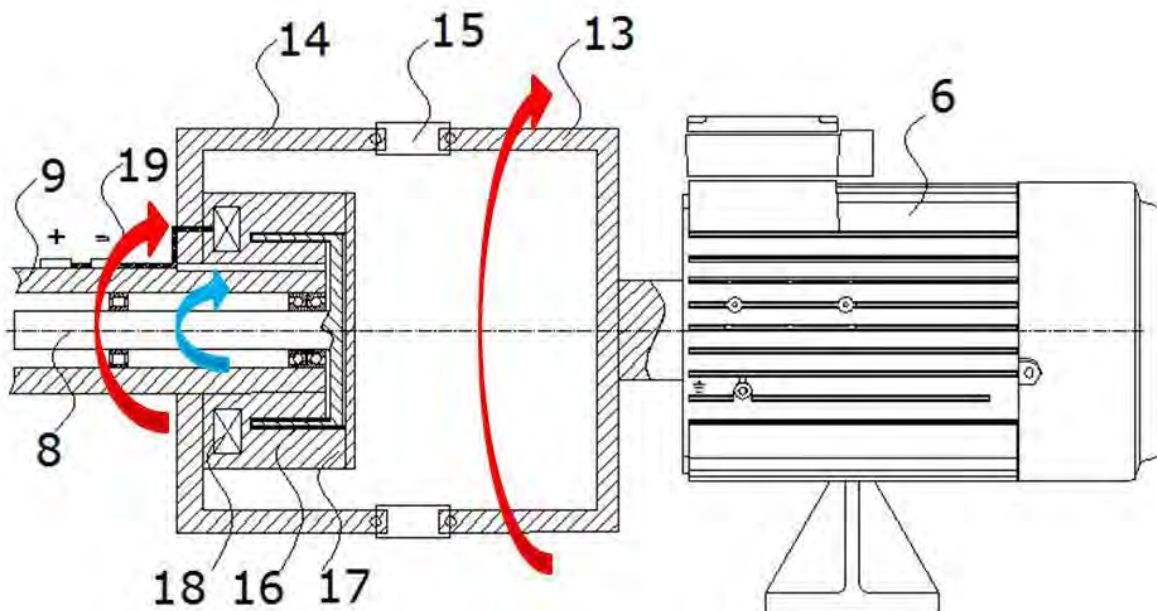
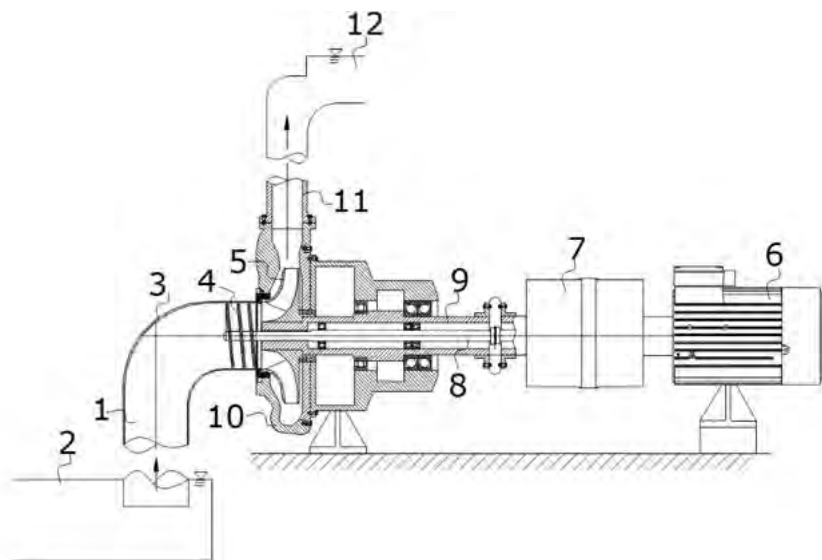

INVENTORS: ICLANZAN TUDOR ALEXANDRU, STAN DANIEL VOICU, TULCAN AUREL, COSMA CRISTIAN, DUME ADRIAN ILIE, TULCAN LILIANA GEORGETA

PATENT NO. 129443 / 2019

MOLD AND METHOD FOR THE INJECTION OF MINIATURE PARTS



The claimed method propose a new non-conventional approach for forming small plastic parts from thermoplastic material detached from a plastic strip as raw material.

As method, the shaping of the small/miniature parts as described below, is done by copying the geometry of a nest by the molten plastic material brought into this and melted here as a result of the thermal conversion of the mechanical energy provided by an ultrasonic activation system attached to the molding device and not by using of a conventional, regular, injection machine which melts the raw material.

The claimed equipment for carrying out the method looks like a regular mold, Figure 1, which carries in the movable half an attached ultrasonic system US1, (4), whose concentrator (6) participates himself with its front side at the nest configuration (case 1) or it will work as a plunger in the injection antechamber as shown in Figure 2 and 3 (case 2). For better results, a second ultrasonic system US2 could be attached at the counter plate (8).

In the raised position, the concentrator (6) exits the forming subassembly (A), and the thermoplastic material strip (7) is brought under the front of the concentrator.

Until this moment, this equipment is working is a punching device, having a side piercer for assuring step-by-step advance of the strip.

When the concentrator (6) goes down, it detaches by cutting (punching, through contour) material from the strip, as sufficient amount to form the product to be manufactured.

Next, the concentrator (6) continues the descending race and this detached material is pushed into the forming subassembly (A), in the nest (case 1) or into the injection antechamber (Figure 2 and 3, case 2), it is pressed, at which point the ultrasonic activation system is put into operation. The mechanical energy of the ultrasonic vibration is converted into thermal energy and the pressed material passes into a molten state, it fills the entire cavity copying the shape of this (the basic principle of injection as a forming process). The exceeding material will be evacuated through leakage channels located peripheral on the nest (case 1) or will remain in the injection antechamber as shown in Figure 2 and 3 (case 2).

After forming, the compression of the material in the nest is maintained until the passage in solid state of this, technological step that can be rushed by passing cooling water through the channels of the counter plate (8).

Advantages for using the technology as described above:

- does not require conventional, regular, injection machine;
- the forming of the part to be manufactured is obtained by pressing the melt in the nest and not by flowing, the shrinkage of the material will be uniform in the volume of the part and the dimensional accuracy of this will be better than in the case of conventional injection molding.
- the proposed technology can be applied for the shaping of small products from thermoplastic material with high viscosity that, in the case of the classic microinjection, raises problems of filling the nest. Can be also be applied for nonsuitable material for injection such as fluoropolymers.

Limitations:

The limitation in size and weight of the product that can be modeled may arise from the need to ensure a certain value of the power density on the front, active surface, of the concentrator (6) that needs to be between 15 and 100 W / cm², depending on the nature of the thermoplastic material to be processed. The ultrasonic system used to activate the nest uses frequencies between 20 and 60 KHz, with the nominal power of the ultrasonic generator between 50 and 1000 W.

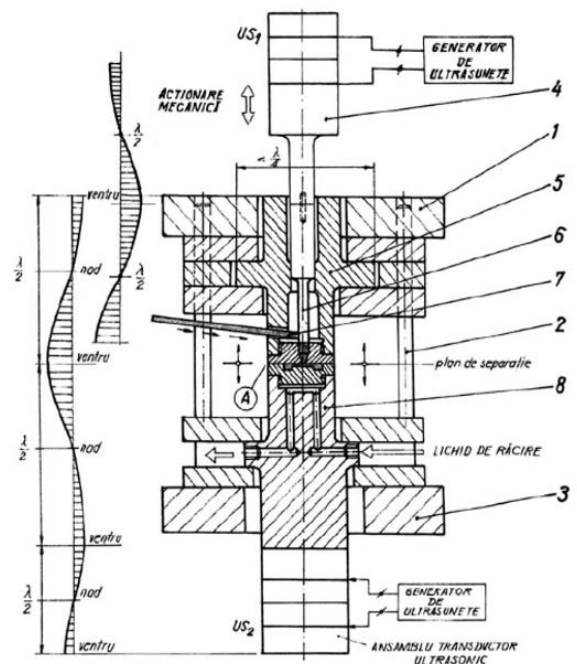

Fig. 1

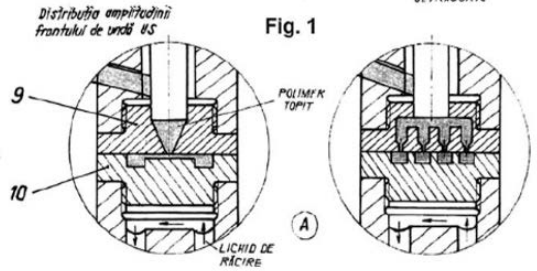

Fig. 2

Fig. 3

INVENTORS: GONTEAN AUREL ȘTEFAN, CERNAIANU MIHAIL OCTAVIAN

PATENT NO. 129477 / 2019

HYBRID THERMOELECTRIC SOLAR SYSTEM



The invention relates to a solar thermal system - electric, hybrid, which produces domestic hot water and electricity using thermoelectric modules.

The solar thermo-electric hybrid (figure 1) is composed of a concentrator, 1, with paraboloid cavity covered with reflecting mirrors, 2 (figure 3), arranged in a mosaic, over the interior surface, to ensure the capture and reflecting the sun light in a concentrated way towards the upper end of a collector 3, containing the TEGs, which provides the conversion of solar energy collected into electrical energy by means of a support 4, placed on a frame 5, shaped "L", which supports both the concentrator, 1 and the collector, 3 in various positions.

To ensure the maximum efficiency the solar tracking is possible using a tilt mechanism, 6, and pan mechanism, 7, 8. The baseplate, 9 has enough sturdiness to permit the attachment of the system and offer stability against wind.

The parabolic collector/concentrator 1, contains even shaped hexagonal mirrors, 10 and PV cells, 2 (figure 2). The electrical efficiency of the system and the hot water produced can be optimized by modifying the amount of photovoltaic cells used on the surface of collector. The energy of sunlight which enters the mirrors parallel to their plane is focused along the focal point, where the TEG 3, is placed.

Figure 1 represents the proposal for the solar collector, 3, built around the TEGs to produce the hot water and electricity. The TEG is placed in a cylindrical glass-like shaped duralumin with a lateral connection 12, connected to a vacuum pump. In the opposite side there is a hole filled with a rubber stopper 13, which ensure a good isolation and where wires attached to 4 connected serially TEGs, 14, exit from the module. The connection is made using low thermal conductivity fiber screws, 15. A black body metal plate, 16, ensure a good light absorption and a good thermal connection between the TEGs and the rest of the module. In the upper side of the module, a circular window is covered with a convex heat-resistant glass, 17, with good optical properties. The glass window is glued with a sealant ring, 18, to ensure a hermetic tightness. To obtain a good thermal isolation between the hot and cold junction of the TEG, the air is removed from the cylindrical cavity using a vacuum pump obtaining a low pressure of $\sim 10^{-2}$ mbar. The bottom of the cylindrical shape, 11, is fixed with screws, 19, to a metal plate, 20, which contains high thermal conductivity aluminum silver anodized tubes, 21. The inside of the tubes are filled with an adequate liquid to ensure the heat transfer from the TEG module to the storage boiler. The module is connected to the "L" shaped bar, 4 and the support, 5 of the solar thermo-electric system with two isolation rings which ensure good thermal isolation from the system chassis.

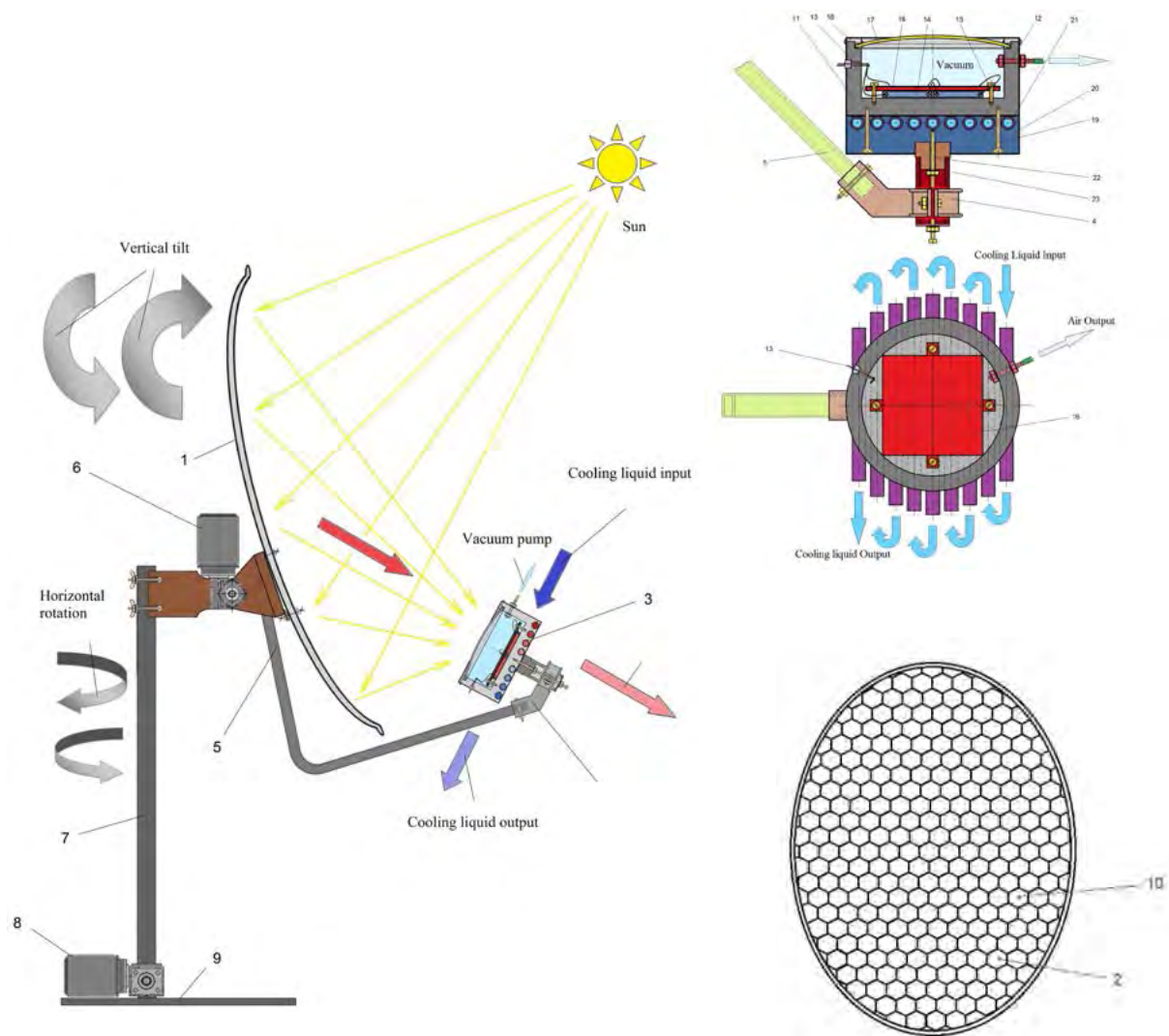

INVENTORS: HEPUȚ TEODOR, CRIȘAN EUGEN, ARDELEAN ERIKA, SOCALICI ANA, ARDELEAN MARIUS

PATENT NO. 127756 / 2019

CYLINDRICAL MULTI-HOLLOW BRIQUETTE PRODUCED OF FERROUS PULVEROUS WASTE



The invention relates to a cylindrical multi-hollow briquette obtained from ferrous pulverous and small waste with a grain size of less than 2 mm, said briquette being used in ferrous metallurgy in the wind furnaces producing the refining iron or in the installations for direct reduction of iron in order to produce iron sponge.

The multi-hollow cylindrical shape of the lighter ensures the growth of the reaction surfaces, respectively of the speed of reduction of iron oxides, compared to conventional lighters, with positive effects on productivity, energy consumption and on the degree of usage of the reductant. Also, using them in reducing ovens ensures a good permeability to gases of the material column.

Ferrous waste in the composition: steel plant dust, furnace dust, furnace agglomeration sludge and iron scale sludge.

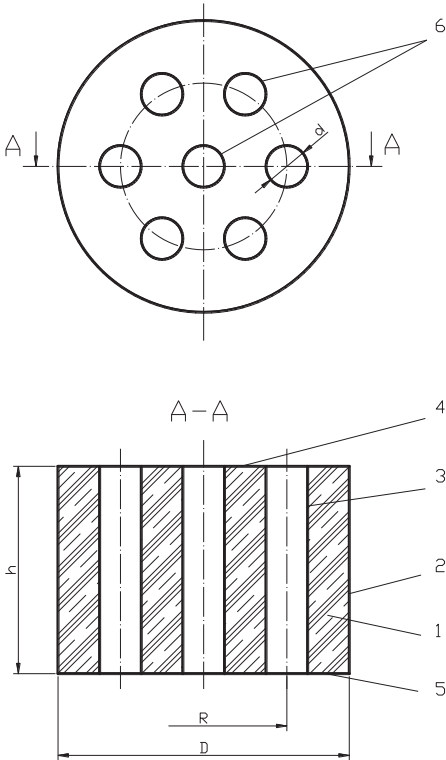

INVENTORS: SUSAN-RESIGA ROMEO-FLORIN, MUNTEAN SEBASTIAN, TĂNASĂ CONSTANTIN, BOSIOC ILIE ALIN, CIOCAN TIBERIU, POPESCU CONSTANTIN

PATENT NO. 131408 / 2019

EQUIPMENT FOR CONTROLLING INSTABILITIES OF SWIRL FLOW FROM THE CONICAL DIFFUSER OF HYDRAULIC TURBINES



The invention relates to an equipment for controlling the instabilities of the swirl flow from the conical diffuser of hydraulic turbines which run at partial flow rate.

According to the invention, the equipment comprises a bypass pipe (11), a regulating gate (VR), a rotary valve (VO), a calming basin (R) and water injection pipe (12) which, connected in series, link an upstream reservoir (1) and a rotor of the turbine (7), the bypass pipe (11) is connected to a pipe (2) for the delivery of water from the upstream reservoir (1), and the bypass pipe (11) is continued by the regulating gate (VR) which controls the flow rate of the pulsatile jet.

