

up

Universitatea
Politehnica
Timișoara

Research Report 2014

**Research
Annual
Report**

Politehnica
University
of Timisoara

2014

Research Report 2014

Research Report, 2014

Copyright © Editura Politehnica 2015

All rights reserved to Politehnica University of Timisoara.

No part of this booklet may be reproduced or transmitted in any form or by any means, electronic or mechanical, including photocopy, recording, or any information storage and retrieval system now known or to be invented, without permission in writing from the publisher, except by a reviewer who wishes to quote brief passages in connection with a review written for inclusion in a magazine, newspaper, or broadcast.

Editorial team

Editor:

Prof. Marius-Emil OTEȘTEANU, PhD

Co-Editors:

Roxana Mihaela SÎRBU

Iris MIHAI

Layout & cover design: Eugen STAN

Editura Politehnica

Bd. Republicii, nr. 9, 300159

Timisoara, România

Phone: +40 256 403823

Fax: +40 256 403021

ISSN 1841-2769

Research
Report 2014

**Research
Annual
Report**
Politehnica
University
of Timisoara
2014

Structure of the report

Introducing the Report.....	5
Research Centers.....	9
Scientific Excellence Awards	15
Projects supported by public funds.....	29
Project in highlight.....	33
Research Projects.....	43
Projects supporting research.....	97
Projects supported by private funds.....	107
Patents.....	131
Granted Patents.....	133
Patent Requests.....	135
Utility Models.....	141
Doctor Honoris Causa.....	145
Professor Emeritus.....	149
Habilitation Theses.....	153
PhD Theses.....	163
Scientific Conferences.....	173
Scientific Journals.....	181
ISI Papers.....	187
ISI Publications.....	189
ISI Proceedings.....	201
Books.....	209

Introducing the Report

“It’s not the walls that make a school, but the spirit living inside.”
King Ferdinand I, 1923

The needs for a modern society, in the context of a competitive global market, require highly skilled human resource development. In this context, the role of universities in the innovation process has increased continuously over time because the development of new products or technologies depends increasingly on the findings of scientific research.

The mission of the Politehnica University of Timisoara is to offer nationally competitive and internationally recognized opportunities for Learning, Research, and Innovation at the highest levels of excellence. As a knowledge resource to the public, the university builds partnerships with other educational institutions, community organizations, government agencies, and the private sector to fulfill the requirements for competences of the societal environment through superior professional training for students and graduates.

The present Research Report of Politehnica University of Timisoara gathers the main results obtained through the research activities carried out within the university in 2014, Politehnica being renowned as a remarkable actor on the stage of scientific research, both at national and international level. Our research activity is facilitated by the existence of twenty-five research centres specialized in fields that are capital for the sustainable development of any modern society. Each of these research centres brings together various prestigious researchers, whom, by their effort and vision, provide UPT with the incentives needed to contribute to the progress of our society.

Most of the research activity carried out by our institution is financed through external sources, obtained either from national and international calls for projects, or through agreements with private companies. This represents a confirmation of the superior quality of the research, but also of the prestige and professional deontology of the researchers affiliated to our institution. Politehnica’s reputation as an institution of advanced research is emphasized also by the patents obtained by its researchers, by the medals and prizes obtained in both national and international competitions, and by the collaborations with important research centres and institutes from Romania and from abroad.

Each year, we select the most talented young researchers for our doctoral school, providing them with the opportunity to transform their knowledge and ideas into the innovations of tomorrow. Many of them take part in peer learning programs consolidating the relationship between our university and similar partner institutions. They strive for becoming doctors in science and for making the world a better place.

This report is divided into thirteen sections, each one presenting a specific component of the research activity performed within the institution.

In the first section, the research infrastructure is presented, which comprises the twenty-five research centres hosted by the university. The order in which they are presented is given by the research fields. The important number of research centres, respectively teams of researchers constituted ad-hoc, on different themes, successfully put in practice the scientific research strategy of the university, within the framework of numerous grants and contracts won by competition. The results of the research are materialized in papers, patents and products, all bringing for the University prestige, as well as important funds.

The second section of the Research Report is dedicated to the Scientific Excellence Awards. This section has three subsections: the Romanian Academy Awards („Anghel Saligny” Award received by Prof. Dan Dubină, and Viorel UNGUREANU, and „Costin D. Nenițescu”

Award, received by Prof. Daniel HĂDĂRUGĂ, and Geza BANDUR), the IEEE Nikola Tesla Award received by Prof. Ion BOLDEA, and the UEFISCDI Awards granted for eighty-seven scientific papers.

The third and fourth sections include the research projects implemented by the university. The third section includes the projects supported by public funds, both national and international, while the fourth one includes the projects supported by private funds awarded by companies. For the purposes of this report, we have chosen the most relevant projects for our research capacity. Within each section, the projects are arranged by research fields.

The innovative capacity of the University Politehnica Timisoara is supported by teachers and scientific researchers through patents and utility models invented, presented in the fifth section.

Politehnica University of Timisoara recognizes scientific excellence by conferring the honorary degree of Professor Emeritus and Doctor Honoris Causa to distinguished Researchers for their contribution to the development of UPT and continuous support, as is shown in sections six and seven.

Sections eight and nine include habilitation theses and PhD theses held in 2014 in our University.

Section ten presents an overview of the most relevant scientific conferences that brought together professionals from Romania and from abroad, hosting and encouraging the dialogue, exchange of ideas and the opportunity for new collaborations.

The eleventh section gathers the scientific journals that have been edited by our institution. This category includes journals specialized in various fields like computer science, chemistry and environmental engineering, electronics and communications, economics and social sciences, electrical engineering, hydrotechnics, physical education and sport, modern languages etc.

The dissemination of research results and findings is an integral part of the research process and the career in academia. In section twelve are presented the most relevant scientific researches that have been published in 2014, comprising the results obtained by our researchers, papers that obtained recognition from some of the most prestigious journals, both from Romania, and from abroad.

And finally the thirteenth section comprises a collection of books written by our researchers, most of them published under Politehnica Publishing House, but not limited to it.

Through research we generate ideas, through ideas we generate innovation and through innovation we contribute to the improvement of the quality of life; this is why research is our priority.

Research Centres



Research Institute for Renewable Energy

Director: prof. Viorel UNGUREANU
Contact: viorel.ungureanu@upt.ro, www.icer.ro



Research Centre for Computers and Information Technology

Director: prof. Vladimir-Ioan CREȚU
Contact: vladimir.cretu@upt.ro, <http://www.cs.upt.ro/~vcretu>



Research Centre for Automatic Systems Engineering

Director: prof. Radu-Emil PRECUP
Contact: radu.precup@upt.ro, <http://www.aut.upt.ro/centru-cercetare>



Research Centre for Power Systems Analysis and Optimization

Director: prof. Ștefan KILYENI
Contact: stefan.kilyeni@upt.ro, <http://www.et.upt.ro/index.php?sublink=1694&link=10&pag=2&lang=ro>



Research Centre for Smart Energy Conversion and Storage

Director: prof. Nicolae MUNTEAN
Contact: nicolae.muntean@upt.ro, <http://www.et.upt.ro/index.php?link=10&sublink=1695&pag=1&lang=en>



Research Centre for Intelligent Electronic Systems

Director: prof. Marius OTEȘTEANU
Contact: marius.otesteanu@upt.ro, <http://www.ccesi.etc.upt.ro/index.php/ro>



Research Centre for Intelligent Signal Processing

Director: prof. Alexandru ISAR
Contact: alexandru.isar@upt.ro, <http://www.tc.etc.upt.ro/isprc>



Research Centre for Multimedia

Director: prof. Radu VASIU
Contact: radu.vasiu@upt.ro, <http://www.cm.upt.ro>



Research Centre for Environmental Science and Engineering

Director: prof. Rodica PODE
Contact: rodica.pode@upt.ro, http://www.chim.upt.ro/Facultatea-de-Chimie-Industriala-si-Ingineria-Mediului-Centru_GF.html



Research Centre for Inorganic Materials and Alternative Energies

Director: prof. Ioan LAZĂU

Contact: ioan.lazau@upt.ro, http://www.chim.upt.ro/Facultatea-de-Chimie-Industrială-si-Ingineria-Mediului-Centru_Zx.html



Research Centre for Organic, Macromolecular and Natural Compounds' Chemistry and Engineering

Director: prof. Corneliu DAVIDESCU

Contact: corneliu.davidescu@upt.ro, http://www.chim.upt.ro/Facultatea-de-Chimie-Industrială-si-Ingineria-Mediului-Centru_VT.html



Research Centre for Mechanics of Materials and Structural Safety

Director: prof. Dan DUBINĂ

Contact: dan.dubina@upt.ro, <http://www.ct.upt.ro/centre/cemsig/>



Research Centre for Hidrotechnics

Director: prof. Teodor Eugen MAN

Contact: eugen.man@upt.ro, <http://www.ct.upt.ro/centre/cchpm.htm>



Research Centre for Building Services

Director: prof. Ioan BORZA

Contact: ioan.borza@upt.ro, <http://www.ct.upt.ro/centre/ccic/>



Research Centre for Retrofitting of Constructions

Director: prof. Valeriu STOIAN

Contact: valeriu.stoian@upt.ro, <http://www.ct.upt.ro/centre/reco.htm>



Research Centre for Construction and Transportation Substructures

Director: prof. Marin MARIN

Contact: marin.marin@upt.ro, <http://www.ct.upt.ro/centre/ict/index.htm>



Research Centre for Mechatronics and Robotics

Director: prof. Inocențiu MANIU

Contact: inocentiu.maniu@upt.ro



Research Centre for Medical Engineering

Director: -
Contact: <http://cmpicsu.upt.ro>



Research Centre for Integrated Engineering

Director: prof. George DRAGHICI
Contact: george.draghici@upt.ro, http://www.eng.upt.ro/imf/ccii/index_en.html



Research Centre for Processing and Characterization of Advanced Materials

Director: conf. Bogdan RADU
Contact: bogdan.radu@upt.ro, <http://eng.upt.ro/ccpcma>



Research Centre for Complex Fluid Systems Engineering

Director: prof. Romeo SUSAN-RESIGA
Contact: romeo.resiga@upt.ro, <http://mh.mec.upt.ro/cnisfc>



Research Centre for Thermal Machines and Equipments, Transportation and Environmental Pollution Control

Director: prof. Ioana IONEL
Contact: ioana.ionel@upt.ro, <http://mettcp.mec.upt.ro/>



Research Centre for Engineering and Management

Director: prof. Monica IZVERCIANU
Contact: monica.izvercianu@upt.ro, <http://www.mpt.upt.ro/pag/centru%20cercetare.html>



Research Centre for Urban Planning

Director: prof. Radu RADOSLAV
Contact: radu.radoslav@upt.ro, <http://ccddt.blogspot.ro>



Research Centre for Advanced Study Methods for Physical Phenomena

Director: prof. Dumitru TOADER
Contact: dumitru.toader@upt.ro, <http://www.et.upt.ro/etf/index.php?sublink=24&link=2&lang=ro>

Scientific Excellence Awards

ANGHEL SALIGNY ROMANIAN ACADEMY AWARD - For the book: Dubina, D., Ungureanu, V., Landolfo, R. DESIGN OF COLD-FORMED STEEL STRUCTURES

Dan DUBINA, Viorel UNGUREANU, Raffaele LANDOLFO, Design of Cold-formed Steel Structures, ECCS (ISBN: 978-92-9147-107-2) - Wiley-Blackwell-Ernst&Sohn (ISBN: 978-3-433-02979-4), ECCS - European Convention for Constructional Steelwork, 2012.

Summary

The book, of more than 650 pages, is concerned with design of cold-formed steel structures in building based, mainly, on the Eurocode 3 package, particularly on EN 1993-1-3. It contains the essentials of theoretical background and design rules for cold-formed steel sections and sheeting, members and connections for building applications. The peculiar behaviour characteristics of thin-walled cold-formed steel sections and their implication in design approaches are emphasised and clearly explained. Both theoretical and relevant technical contributions of the authors are integrated within the book chapters. Elaborated examples and design applications - more than 200 pages, accompanied by design oriented flow charts - are included in the respective chapters in order to provide a better understanding to the reader.

Purpose and Motivation of the book:

The use of cold-formed steel members in building construction began in the 1850s in both the United States and Great Britain. In the 1920s and 1930s, acceptance of cold-formed steel as a construction material was still limited because there was no adequate design standard and there was limited information on material use in building codes. One of the first documented uses of cold-formed steel as a building material is the Virginia Baptist Hospital, constructed around 1925 in Lynchburg, Virginia, USA. 20 years later, only, Lustron Corporation built in Albany, New York, 2500 steel-framed homes, with the framing, finishes, cabinets and furniture made from cold-formed steel. These inexpensive houses were built for the veterans returning from the World War II. This was the beginning of cold-formed steel adventure in building.

In recent years, cold formed steel sections are used more and more as primary framing components. Wall stud systems in housing, trusses, building frames or pallet rack structures are some examples. As secondary structural systems they are used as purlins and side rails or floor joists, as well as in building envelopes. Cassette sections in modern housing systems play simultaneously the role of primary structure and envelope. Profiled decking is widely used as basic components in composite steel-concrete slabs.

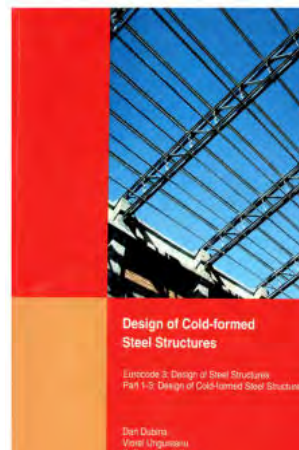

Cold-formed steel members are efficient in terms of both their stiffness and strength. Additionally, because the base steel is thin, even less than 1 mm thick when high strength steel is used, the members are lightweight. The use of thinner sections and high strength steel leads to design problems for structural engineers which may not normally be encountered in routine structural steel design. Further, the shapes which can be cold-formed are often considerably more complex than hot-rolled steel shapes, such as I sections and plain channel sections. The cold-formed sections commonly have mono-symmetric or point symmetric shapes, and normally have stiffening lips on flanges and intermediate stiffeners in wide flanges and webs. Both simple and complex shapes can be formed for structural and non-structural applications.

Cold-formed steel design is dominated by two specific problems, i.e. (1) stability behaviour, which is dominant for design criteria of thin sections, and (2) connecting technology, which is specific and influences significantly the structural performance and design detailing. Special design standards have been developed to cover the specific problems of cold-formed steel structures. In the USA, the Specification for the design of cold-formed steel structural members of the American Iron and Steel Institute was first produced in 1946 and has been regularly updated based on research to the most recent 2007 edition, AISI S100-07, entitled North American Specification for Design of Cold-Formed Steel Structural Members. In Europe, the ECCS Committee TC7 originally produced the European Recommendations for the design of light gauge steel members in 1987 (ECCS, 1987).

This European document has been further developed and published in 2006 as the European Standard Eurocode 3: Design of steel structures. Part 1-3: General Rules. Supplementary rules for cold-formed thin gauge members and sheeting (EN 1993-1-3, 2006). In Australia and New Zealand, the last version of specification for the design of cold-formed steel structures, AS/NZS 4600, was published in December 2005, and the review of cold-formed steel design specification could be continued around the world.

The market share of cold-formed structural steelwork continues to increase in the developed world. The main reasons can be found in the improving technology of manufacture and corrosion protection which leads, in turn, to an increased competitiveness of resulting products as well as new applications. Recent studies have shown that the coating loss for galvanized steel members is sufficiently slow, and indeed slows down to effectively zero, than a design life in excess of 60 years can be guaranteed. The range of use of cold-formed steel sections specifically as load-bearing structural components is very wide. Besides building applications, cold-formed steel elements can be met in the Automotive industry, Shipbuilding, Rail transport, in Aircraft industry, Highway engineering, Agricultural and Industry equipment, Office equipment, Chemical, Mining, Petroleum, Nuclear and Space industries.

Interested Public

The book was conceived primarily as a technical support for structural engineers in design and consulting offices, but it is expected to be of interest and useful for students and staff members of structural engineering faculties, as well as, for engineers working in steelwork industry.

Reviews

The authors are clearly extremely experienced in the structural design and behaviour of cold-formed steel and they are also deeply knowledgeable about the content of EN 1993-1-3. The credentials of the authors and fact that the book forms part of the ECCS series of Eurocode Design Manuals means that this will become an authoritative text for engineers with an interest in the design of cold-formed steel (The Structural Engineer, 1 July 2013).

The authors

Dan Dubina, corresponding Member of Romanian Academy, is professor and head of the Department of Steel Structures and Structural Mechanics at the Politehnica University of Timisoara, Romania. He has published more than 400 scientific papers and 25 books in the field of cold-formed steel structures, steel structures in seismic areas, structural connections, and structural analysis. He is a member of the ECCS Technical Committees TC 7 (Cold Formed Thin Walled Sheet Steel in Building), TC 8 (Stability), TC 10 (Connections), and TC 13 (Seismic Design). He has been awarded with the ECCS European Steel Design Award twice.

Viorel Ungureanu is professor at the Politehnica University of Timisoara, Romania. His experience in the field of steel structures, light steel structures, rehabilitation and sustainability of constructions is reflected in more than 200 scientific papers and 15 books and edited volumes. He participated in the drafting teams for the Romanian design code and technical regulations for steel structures. He is a member of the ECCS TC 7 (Cold Formed Thin Walled Sheet Steel in Building) and TC 14 (Sustainability and Eco-Efficiency of Steel Buildings).

Raffaele Landolfo is professor of structural engineering and head of Head of Department of Structures for Engineering and Architecture University of Naples "Federico II". He is external examiner for MSc in earthquake engineering and structural steel design at the Imperial College London and he also teaches in several PhD and master courses. He was engaged in the activities of both national working groups and European project teams dealing with the conversion from ENV to EN of the EN 1993-1-3, and he is chairing the ECCS Technical Committee TC 13 (Seismic Design).

According to WorldCat data base, the 2012 and 2013 editions of the book are already present in 121 libraries Worldwide.

COSTIN D. NENIȚESCU ROMANIAN ACADEMY AWARD for (Chemical Sciences section)

Costin D. Nenițescu AWARD of the ROMANIAN ACADEMY on Chemical Sciences section for the scientifically work of the year 2012, has been awarded for the scientifically contribution entitled: **The influence of water content of cyclodextrin-based complexes on the structural descriptors of biologically active compounds**. This award was given for two research articles on the border of chemical/bioconjugation / supramolecular interaction and the involvement to the stability / bioactivity / bioavailability of flavonoid and essential oil – cyclodextrin nanoparticles.

The authors

Daniel I. HĂDĂRUGĂ is assistant professor at the Department of Applied Chemistry, Organic and Natural Compounds Engineering, Politehnica University of Timișoara.

He received the Ph.D. degree in chemistry in 2003. The main research topic includes the obtaining and analysis of new dual bioactive compounds (such as antioxidant derivatives and bioconjugates) and micro- / nanoencapsulation in cyclodextrins and liposomes. He is published many research articles and book chapters (Wiley, USA and Franche-Comté, France) in this area and is reviewer for top journals in chemical and food fields.

Nicoleta G. HĂDĂRUGĂ is full professor at the Banat's University of Agricultural Sciences and Veterinary Medicine "King Mihai I of Romania", Timișoara, Department of Food Science from the Faculty of Food Processing Technology.

She obtained the Ph.D. degree in Chemical Engineering in 2005 at the Polytechnic University of Timișoara and the Habilitated Doctor in 2013. Professor Nicoleta Hădărugă's research interests include protection / stability and controlled release of biologically active compounds from cyclodextrins. She is international journal reviewer and Editor-in-Chief of the J. Agroalim. Food Chem. and Organizing Chair of The 8th International Conference on Water in Food.

Geza N. BANDUR is associate professor at the Department of Applied Chemistry, Organic and Natural Compounds Engineering, Politehnica University of Timișoara.

He received the Ph.D. degree in 1999. Professor Geza Bandur's expertise is especially the synthesis and analysis of carbohydrate based polymers as well as advanced thermal analysis methods. He has published numerous research articles on thermogravimetry and differential scanning calorimetry analysis of oligo- and polymer based materials

Heinz-Dieter ISENGARD is Emeritus Professor at the University of Hohenheim, Stuttgart.

Professor Isengard received the Ph.D. degree in chemistry in 1972 and had numerous scientifically and administrative positions. He is the president of Association EuroFoodWater and organized many international conferences of food chemistry.

Water content of flavonoid/cyclodextrin nanoparticles: relationship with the structural descriptors of biologically active compounds

Authors: Daniel I. Hădărugă, Nicoleta G. Hădărugă, Geza N. Bandur, Heinz-Dieter Isengard

Journal: Food Chemistry (Elsevier) 2012, 132(4), 1651-1659, doi: 10.1016/j.foodchem.2011.06.004 (ISI2012 = 3.334)

Abstract

The paper presents a study regarding the obtaining, characterization, and water evaluation of flavonoid (flavone, chrysin, naringenin, hesperetin, apigenin, fisetin, luteolin) and related compounds (cinnamic and caffeic acids, silybin etc.)/cyclodextrin complexes.

The thermogravimetric and calorimetric analyses indicate the formation of complexes, the presence of bioflavonoids and related compounds being revealed by the larger peaks from the calorimetric analysis (up to 250°C); the dissociation of water and other volatiles (ethanol) is revealed by thermogravimetry.

The Karl Fischer titration (KFT) water content of β cyclodextrin complexes obtained by crystallization method was in the range of 8.8% (chrysin) to 12.6% (caffeic acid), and higher for ultrasonication method (9.4-13.3%).

For α -cyclodextrin complexes the water content was lower (8.2-9.8%). KFT water content correlates with the hydrophobic descriptors (i.e. octanol-water partition coefficient). This observation demonstrates the molecular encapsulation of compounds such as bioflavonoids in cyclodextrin cavity by replacing of crystallization water molecules with the more hydrophobic guest compounds.

Keywords

flavonoids; cyclodextrins; nanoparticles; Karl Fischer water titration; thermogravimetry; differential scanning calorimetry; structural descriptors.

Goal

In the present study the influence of structural characteristics of biologically active compounds from flavonoid, cinnamic acid, and flavanolignan classes on the encapsulation process in cyclodextrins by means of water content and the correlation of this water content with flavonoid structures and with the type of complexation method were investigated.

Conclusions

- The study regarding the obtaining, characterization, and water content evaluation of flavonoid and related compounds/ α - and β -cyclodextrin complexes revealed that the formation of the complex depends of the hydrophobicity of the guest compound (expressed by different descriptors), but only in the case of obtaining of complexes by crystallization method.
- Thus, the water content of cyclodextrin complexes, determined even by classical Karl Fischer titration or evaluated by thermogravimetry, depend on the hydrophobic (or related) descriptors of guest compound, especially for β -cyclodextrin complexes, the best correlation being obtained for logP (logarithm of octanol-water partition coefficient) and Nnp (total number of non-polar atoms); good correlations were obtained also for the water solubility descriptor (LogS), which are correlated (inverse correlation) with the hydrophobicity descriptors.
- These correlations were obtained only for the case of obtaining of cyclodextrin complexes by crystallization method and can be explained by the possibility to touch the association/dissociation equilibrium between guest (flavonoid and related compounds) and host (cyclodextrin) by very slow crystallization, when some of the water molecules from cyclodextrin are replaced by the guest molecule; if the guest molecule are more hydrophobic the van der Waals interaction with the inner cavity of cyclodextrin is better and the water content of the final complex is reduced. Furthermore, the obtaining of cyclodextrin complexes by ultrasonication method is inappropriate due to the facility of dissociation of guest-cyclodextrin complex in this process, as is revealed by the higher water content of these complexes.
- The water content determined by classical Karl Fischer method seems to be the better method for water evaluation in cyclodextrin micro/nanoparticles; thermogravimetry conduct to similar results, but little bit lower than the above mentioned method, due to the analysis technique: the TG analysis starts after obtaining the inert atmosphere (nitrogen) in the balance space and in this period a small quantity of water is already lost
- Moreover, the KFT allow evaluating only the water content and TG analysis indicate the mass loss by increasing temperature and do not differentiate between water and other volatile compounds,

Water content of natural cyclodextrins and their essential oil complexes: A comparative study between Karl Fischer titration and thermal methods

Authors: Nicoleta G. Hădăruță, Daniel I. Hădăruță, Heinz-Dieter Isengard

Journal: Food Chemistry (Elsevier) 2012, 132(4), 1741-1748, doi: 10.1016/j.foodchem.2011.11.003 (ISI2012 = 3.334)

Abstract

The paper presents a comparative study regarding the water determination in natural cyclodextrins and in their essential oil complexes (Apiaceae, Liliaceae, and Cupressaceae families) by using Karl Fischer titration (KFT) and thermal methods.

For the natural cyclodextrins the influence of the solvent hydrophobicity and the preheating temperature on the water extraction process were evaluated. The water contents, estimated by KFT in both methanol and methanol-octanol solvent systems, were 10.6% and 14.4% for α and β -cyclodextrin, respectively.

The water content, estimated by KFT in a more hydrophilic solvent system, methanol-formamide, was 0.4-0.6% higher.

Thermogravimetric evaluation of water conducts to lower values. For the essential oil/cyclodextrin complexes, the KFT water content were in the range of 6.4-8.1%, higher values being obtained in the case of Juniperus essential oil/ β cyclodextrin complexes (7.5-8.1%). With some exceptions, thermal analyses of complexes are in good agreement with the KFT results.

Keywords

Karl Fischer water titration; microparticles and nanoparticles; cyclodextrins; thermogravimetry; differential scanning calorimetry; scanning electron microscopy.

Goal

In this study the influence of the hydrophobicity of solvent mixture and the preheating temperature on the water extraction process for α - and β -cyclodextrin as well as for their complexes with various essential oils were evaluated by using classical Karl Fischer titration method and the results were compared with those from the thermogravimetric analysis.

Conclusion

- Classical Karl Fischer water titration is a good tool for evaluation of water concentration in cyclodextrins and their micro/nanoparticles used in food industry and KFT results are in good agreement with the thermogravimetric results; the KFT chemical method is more accurate than TG due to the fact that it evaluate only water concentration and furthermore the "surface" and "strong-bonded" water molecules can be determined.
- Karl Fischer water titration values for natural cyclodextrins depend on the hydrophobicity of solvent mixture: lower values were obtained in the case of more hydrophobic solvent addition to the methanol used as the base solvent. The differences between KFT water content values for natural cyclodextrins and their essential oils complexes is still small from the solvent hydrophobicity point of view and further investigations must be performed in order to elucidate all aspects of cyclodextrin Karl Fischer titration.

IEEE NIKOLA TESLA AWARD - Prof. Ion Gheorghe BOLDEA, PhD

- The IEEE Nikola Tesla Award was established in 1975 through an agreement between the IEEE Power Engineering Society and the IEEE Board of Directors.
- The Award is named in honor of Nikola Tesla, an electrical engineer, a distinguished Yugoslav-American inventor, and a pioneer in many fields, who is most renowned for the development of the coil that bears his name and the a-c induction motor.
- The IEEE Nikola Tesla Award is granted for outstanding contributions to the generation and utilization of electric power.

BIOGRAPHY

Prof. Ion Gheorghe BOLDEA, PhD in Electrical Engineering in 1973 has worked exclusively for University Politehnica Timisoara Romania, but spent more than 5 years in total as visiting scholar in USA and UK, while delivering intensive courses, keynote addresses IA-IEEE DLs (since 2008) in USA, S. America, EU and Asia, with technical consulting over decades for companies like GM, Bosch, Vestas, Hilti, Hyosung, EMBRACO, Scumberger etc.

His technical expertise is related to electric energy conversion and control by power electronics for better industrial productivity, energy savings and air pollution reduction. Besides the academic involvement he was a founding co-owner for 20 years of an industrial digital electric automation (IDEA) private enterprise that has now more than 60 engineers.

His technical expertise is related to electric energy conversion and control by power electronics for better industrial productivity, energy savings and air pollution reduction.

Besides the academic involvement he was a founding co-owner for 20 years of an industrial digital electric automation (IDEA) private enterprise that has now more than 60 engineers.

He worked and published on linear and rotary electric machinery design and control (18 books and more than 150 IEEEExplore papers, 30 patents etc.).

He received 4 IEEE paper awards, and is a member of Romanian Academy of Technical Sciences and of Romanian Academy.

Prof. Boldea initiated cooperation with many universities such as those of Kentucky, Oregon and Texas at Dallas in USA, Cassino, Bologna, Torino, Trieste in Italy, Hanyang in Korea, Aalborg University in Denmark where he holds a Doctor Honoris Causa.

Specific contributions

- The introduction of the optimum goodness factor for the design of linear induction motors of high speed(1976);
- First integrated-propulsion-levitation passive guideway MAGLEV –Magnibus(4 ton prototype on an 150m test track) with linear homopolar synchronous motors and over all power factor and energy conversion above 80% (1986);



- Generalization in 1988 of the to be DTC (in 1995), proposed initially (1985) only for IMs, under the name of TVC, for both voltage and current source inverter, for all ac motor drives;
- The design and testing the largest power factor(0.91, at 1500W and 3.6krpm) reluctance synchronous motor (2 poles, ALA rotor) in 1992;
- 3rpm full torque sensorless control for an IM DTC drive without signal injection, using sliding mode observers and regulators(2000);
- The introduction of the first matrix converter in the terminal box of an induction motor(2000);
- The introduction of BEGA(an IPMSM with additional dc excitation in an axis at 90 degrees with respect to magnets axis) to produce very large CPSR at unity power factor and pure resistive generator voltage drop by zero Id and zero Psiq active control (2006);
- Introducing the concept of “active flux” as a unifying concept to simplify sensorless(advanced) control of all ac motor drives(2008);
- Optimal design deterministic and evolutionary methodologies for IMs and SMs with embedded FEM (2010);
- Contribution to the revival and development of No-PM Brushless DC multiphase reluctance machines with dual flat top;
- current control for high performance over wide CPSR with simplified control and applications for electric transport and wind/hydro generators (2012);

EXECUTIVE UNIT FOR FINANCING HIGHER EDUCATION, RESEARCH, DEVELOPMENT AND INNOVATION - UEFISCDI AWARDS

Through these awards UEFISCDI aims to increase quality, impact and international visibility of Romanian research by recognizing and rewarding significant results published in prestigious journals from international senior scientific stream.

Within this competition can participate the researchers affiliated to institutions in Romania, authors of scientific articles published in journals indexed by Thomson Reuters Science Citation Index Expanded ("Science"), Social Sciences Citation Index ("Social Sciences") or Arts & Humanities Citation Index ("Arts & Humanities").

More information at <http://uefiscdi.gov.ro/Public/cat/471/Premierea%20rezultatelor%20cercetarii.html>

1. Ancuti, C., Ancuti, C. O. Effective Contrast-Based Dehazing for Robust Image Matching, IEEE GEOSCIENCE AND REMOTE SENSING LETTERS, Volume: 11, Issue: 11, Pages: 1871-1875, Published: NOV 2014
2. Ardelean, M., Manea, F., Vaszilcsin, N., Pode, R. Electrochemical detection of sulphide in water/seawater using nanostructured carbon-epoxy composite electrodes, ANALYTICAL METHODS Volume: 6 Issue: 13 Pages: 4775-4782, 2014;
3. Belega, D; Petri, D, Sine-wave parameter estimation by interpolated DFT method based on new cosine windows with high interference rejection capability, DIGITAL SIGNAL PROCESSING, 2014;
4. Binzar, T., Lazureanu, C. A Rikitake type system with one control, DISCRETE AND CONTINUOUS DYNAMICAL SYSTEMS-SERIES B Volume: 18, Issue 7, pages: 1755-1776;
5. Binzar, T., Lazureanu, C. On some dynamical and geometrical properties of the Maxwell-Bloch equations with a quadratic control, JOURNAL OF GEOMETRY AND PHYSICS Volume: 70 Pages: 1-8;
6. Birtea, P., Comanescu, D. Popa, C.A. Averaging on Manifolds by Embedding Algorithm, JOURNAL OF MATHEMATICAL IMAGING AND VISION, Volume: 49 Issue: 2, Pages: 454-466;
7. Bistriean, D.A., A solution of the parabolized Navier-Stokes stability model in discrete space by two-directional differential quadrature and application to swirl intense flows, COMPUTERS & MATHEMATICS WITH APPLICATIONS Volume: 68 Issue: 3 Pages: 197-211, Impact factor 1.996;
8. Boboescu, I.Z. et. al. Temperature-dependent transformation of biogas-producing microbial communities points to the increased importance of hydrogenotrophic methanogenesis under thermophilic operation, BIORESOURCE TECHNOLOGY Volume: 177 Pages: 375-380;
9. Boboescu, I.Z., Ilie, M., Gherman, V.D., Mirel, I., Pap, B., Negrea, A., Kondorosi, E., Biro, T., Maroti, G. Revealing the factors influencing a fermentative, BIOTECHNOLOGY FOR BIOFUELS, Volume: 7, Article Number: 139;
10. Fatu, M., Blaabjerg, F., Boldea, I. Grid to stand alone Transition Motion-Sensor less Dual-Inverter Control of PMSG with Asymmetrical Grid Voltage Sags and Harmonics Filtering, IEEE TRANSACTIONS ON POWER ELECTRONICS, Volume: 29, Issue: 7, Pages: 3463-3472;
11. Boldea, I., Tutelea, L. N., Parsa, L. et al. Automotive Electric Propulsion Systems With Reduced or No Permanent Magnets: An Overview. IEEE TRANSACTIONS ON INDUSTRIAL ELECTRONICS, Volume: 61, Issue: 10, Pages: 5696-5711;
12. Borbath, T., Borbath, I., Gunther, S., Marinica, O., Vekas, L. Odenbach, S., Three-dimensional microstructural investigation of high magnetization nano-micro composite fluids using x-ray microcomputed tomography, SMART MATERIALS AND STRUCTURES, Volume: 23 Issue: 5;

13. Bota, C., Caruntu, B. Approximate polynomial solutions of the nonlinear Lane-Emden type equations arising in astrophysics using the squared remainder minimization method, *COMPUTER PHYSICS COMMUNICATIONS* Volume: 184, Issue: 7, Pages: 1643-1648;
14. Bota, C., Caruntu, B. Approximate Analytical Solutions of the Regularized Long Wave Equation Using the Optimal Homotopy Perturbation Method, *SCIENTIFIC WORLD JOURNAL*, 2014;
15. Calinoiu D., Stefu N., Paulescu M., Trif – Tordai G., Mares O., Paulescu E., Boata R., Pop N., Pacurar A., Evaluation of errors made in solar irradiance estimation due to averaging the Angstrom turbidity coefficient, *Atmospheric Research*, Vol. 150, p. 69-78, 2014;
16. Corpas, L., Hadaruga, N.G., David, I., Pirsan, P., Hadaruga, D.I., Isengard, H.D., Karl Fischer Water Titration-Principal Component Analysis Approach on Wheat Flour, *FOOD ANALYTICAL METHODS*, Volume: 7 Issue: 6 Pages: 1353-1358;
17. Craciunescu, C. Ercuta, A. Prediction of thermally-controlled actuation for shape memory alloy film-based bimorph cantilevers, *SMART MATERIALS AND STRUCTURES*, Volume: 23 Issue: 7;
18. Crisan A., Ungureanu V., Dubina D. Influence of web members on the in-plane and out-of-plane capacities of steel storage upright frames. *Thin-Walled Structures*, Volume 81, August 2014, pp. 175–184;
19. Curiac, D.I., Volosencu, C. A 2D chaotic path planning for mobile robots accomplishing boundary surveillance missions in adversarial conditions, *COMMUNICATIONS IN NONLINEAR SCIENCE AND NUMERICAL SIMULATION* Volume: 19 Issue: 10 Pages: 3617-3627;
20. Sas, G., Daescu, C., Popescu, C. et al. Numerical optimization of strengthening disturbed regions of dapped-end beams using NSM and EBR CFRP, *COMPOSITES PART B-ENGINEERING* Volume: 67, pages: 381-390;
21. Dubina D., Ungureanu V. Instability mode interaction: from Van Der Neut model to ECBL approach. *Thin-Walled Structures*, Volume 81, August 2014, pp. 39–49; 2014;
22. Filip-Vacarescu N., Stratan A., Dubina D., Seismic performance of multistorey steel frames with strain hardening friction dampers, *Proceeding of the Romanian Academy, Series A*, Volume 15, Number 2/2014, pp. 174–181;
23. Florut, S. C., Sas, G., Popescu, C., Stoian, V. Tests on reinforced concrete slabs with cut-out openings strengthened with fibre-reinforced polymers, *COMPOSITES PART B-ENGINEERING*, Volume: 66, Pages: 484-493;
24. Gherman, V.D., Boboescu, I.Z., Pap, B., Kondorosi, E., Gherman, G. Maroti, G. An Acidophilic Bacterial- Archaeal- Fungal Ecosystem Linked to Formation of Ferruginous Crusts and Stalactites, *GEOMICROBIOLOGY JOURNAL*, Volume: 31, Issue: 5, Pages: 407-418;
25. Groza, B.; Warinschi, B. Cryptographic puzzles and DoS resilience, revisited, *DESIGNS CODES AND CRYPTOGRAPHY*, Volume: 73, Issue: 1, Pages: 177-207;
26. Hulka, I. et. al. Properties of WC-FeCrAl coatings manufactured by different high velocity thermal spray processes, *SURFACE & COATINGS TECHNOLOGY* Volume: 247, Pages: 74-89;
27. Ianos, R., Babuta, R., Lazau, R. Characteristics of Y2O3 powders prepared by solution combustion synthesis in the light of a new thermodynamic approach, *CERAMICS INTERNATIONAL*, Volume: 40, Issue: 8, Pages: 12207-12211 Part: A;
28. Ianos, R. Highly sinterable cobalt ferrite particles prepared by a modified solution combustion synthesis, *MATERIALS LETTERS*; Volume: 135, Pages: 24-26;

29. Ianos, R., Bosca, M., Lazau, R. Fine tuning of CoFe₂O₄ properties prepared by solution combustion synthesis, CERAMICS INTERNATIONAL, Volume: 40 Issue: 7, Pages: 10223-10229, Part: B;
30. Ianos, R., Lazau, R. Chromium-doped calcium zirconate A potential red shade pigment: Preparation, characterization and testing, DYES AND PIGMENTS, Volume: 105, Pages: 152-156;
31. Ianos, R., Lazau, R., Borcanescu, S., Babuta, R. Single-step combustion synthesis of LaAlO₃ powders and their sintering behavior, CERAMICS INTERNATIONAL, Volume: 40, Issue: 5, Pages: 7561-7565;
32. Ianos, R., Pacurariu, C., Mihoc, G. Magnetite/carbon nanocomposites prepared by an innovative combustion synthesis technique-Excellent adsorbent materials, CERAMICS INTERNATIONAL, Volume: 40, Issue: 8, Pages: 13649-13657, Part: B;
33. Ilinoiu, E.C., Manea, F., Serra, P.A. et al. Simultaneous/Selective Detection of Dopamine and Ascorbic Acid at Synthetic Zeolite-Modified/Graphite-Epoxy Composite Macro/Quasi-Microelectrodes, SENSORS Volume: 13, Issue: 6, Pages: 7296-7307;
34. Iosif, A., Sarbu, I. Numerical modeling of cavitation characteristics and sensitivity curves for reversible hydraulic machinery, ENGINEERING ANALYSIS WITH BOUNDARY ELEMENTS, vol. 41, no. 4, 2014
35. Irimescu, A. Optical characterization of combustion processes in a DISI engine equipped with plasma-assisted ignition system, APPLIED THERMAL ENGINEERING Volume: 69, Issue: 1-2, Pages: 177-187;
36. Irimescu, A., Marchitto, L., Merola, S.S., Tomatore, C., Valentino, G. Evaluation of different methods for combined thermodynamic and optical analysis of combustion in spark ignition engines, ENERGY CONVERSION AND MANAGEMENT, Volume: 87, Pages: 914-927, 2014;
37. Irimescu, A., Vasii, G., Tordai, G.T. Performance and emissions of a small scale generator powered by a spark ignition engine with adaptive fuel injection control, APPLIED ENERGY, Volume: 121, Pages: 196-206;
38. Lelea, D., Laza, I. The water based Al₂O₃ nanofluid flow and heat transfer in tangential microtube heat sink with multiple inlets, International Journal of Heat and Mass Transfer, Volume 69, February 2014, Pages 264-275;
39. Lemle, L.D. On Some Approximation Theorems for Power q -Bounded Operators on Locally Convex Vector Spaces, SCIENTIFIC WORLD JOURNAL Article Number: 513162;
40. Lemle, L.D. On the L -infinity-uniqueness of multidimensional Nelson's diffusion, CARPATHIAN JOURNAL OF MATHEMATICS, Volume: 30, Issue: 2, Pages: 209-215;
41. Lemle, L.D., Wang, R., Wu, L.M. Uniqueness of Fokker-Planck equations for spin lattice systems (II): Non-compact case, SCIENCE CHINA MATHEMATICS, Volume: 57, Issue: 1, Pages: 161-172;
42. Lupa, N. Roughness of $(Z(+), Z(-))$ -Nonuniform Exponential Dichotomy for Difference Equations in Banach Spaces, SCIENTIFIC WORLD JOURNAL, Article Number: 819046;
43. Lupa, L., Negrea, A., Ciopec, M., Negrea, P. Cs⁺ Removal from Aqueous Solutions through Adsorption onto Florisil (R) Impregnated with Trihexyl(tetradecyl)phosphonium Chloride, MOLECULES Volume: 18, Issue: 10, Pages: 12845-12856;
44. Marinca, V., Ene R. D., Marinca, B. Analytic approximate solution for Falkner - Skan equation, The Scientific World Journal, Special Issue: Dynamics of Nonlinear Systems (DNS), Article ID: 617453, 2014;

45. Marinca, V. Herisanu, N. On the flow of a Walters-type B' viscoelastic fluid in a vertical channel with porous wall, INTERNATIONAL JOURNAL OF HEAT AND MASS TRANSFER, Volume: 79, Pages: 146-165, 2014;
46. Marinca, V., Herisanu, N. The Optimal Homotopy Asymptotic Method for solving Blasius equation, APPLIED MATHEMATICS AND COMPUTATION, Volume: 231, Pages:134-139;
47. Marinica, O., Vasile, E., Vekas, L. Fabrication and characterization of superparamagnetic poly(vinyl pyrrolidone)/poly(L-lactide)/Fe₃O₄ electrospun membranes, JOURNAL OF MAGNETISM AND MAGNETIC MATERIALS, Volume: 352, Pages: 30-35;
48. Marinica, O., Vekas, L. An innovative synthesis approach toward the preparation of structurally defined multiresponsive polymer (co)networks, POLYMER CHEMISTRY, Volume: 5 Issue: 14 Pages: 4365-4374, 2014;
49. Marinica, O., Vasile, E., Vekas, L. Fabrication, Characterization, and Evaluation in Drug Release Properties of Magnetoactive Poly(ethylene oxide)-Poly(L-lactide) Electrospun Membranes, BIOMACROMOLECULES, Volume: 14, Issue: 12, Pages: 4436-4446;
50. Miclau, M., Miclau, N. Low-temperature hydrothermal synthesis of the three-layered sodium cobaltite P₃-Na_xCoO₂ (x similar to 0.60), MATERIALS RESEARCH BULLETIN Volume: 54, Pages: 1-5;
51. Mihet-Popa, L. Electrical Vehicle Batteries Testing in a Distribution Network Using Sustainable Energy, IEEE TRANSACTIONS ON SMART GRID, Volume: 5, Issue: 2, Pages: 1033-1042;
52. Minculete, N., Ciurdariu, L. A generalized form of Gruss type inequality and other integral inequalities, JOURNAL OF INEQUALITIES AND APPLICATIONS;
53. Mitelea, I., Groza, C., Craciunescu, C.M. Pulsed Laser Processing of Dissimilar Ti-6Al-4V and X5CrNi18-10 Joints, MATERIALS AND MANUFACTURING PROCESSES, Volume: 29 Issue: 8, Pages: 975-979;
54. Mitelea, I., Dimian, E., Bordeasu, I., Craciunescu, C.- Ultrasonics Sonochemistry Volume: 21, Issue: 4 Published: JUL 2014, ISSN: 1350-4177, Pages: 1544-1548;
55. Gioncu, V., Mosoarca M., Anthimos, A, Local ductility of steel elements under near-field earthquake loading, Journal of Constructional Steel Research, Volume 101, Octombrie 2014, Pages 33-52, 2014, Editura Elsevier, ISSN: 0143-974X;
56. Mutascu, M.I., Albulescu, C.T. The influence of the international oil prices on the real effective exchange rate in Romania in a wavelet transform framework, ENERGY ECONOMICS, Volume: 40, Pages: 714-733;
57. Negru, R., Muntean, S., Pasca, N., Marsavina, L. Failure assessment of the shaft of a pumped storage unit, FATIGUE & FRACTURE OF ENGINEERING MATERIALS & STRUCTURES, Volume: 37 Issue: 7 Pages: 807-820 Special Issue: SI;
58. Palade, A., Cicala, E., Marsavina, I. Subsurface treatment of a contact subjected to a hertz pressure, INTERNATIONAL JOURNAL OF MECHANICAL SCIENCES, Volume: 77, Pages: 107-112;
59. Pana, A.M., Badea, V., Banica, R., Bora, A., Dudas, Z., Cseh, L., Costisor, O. Network reaction of 2,6-bis(2-hydroxybenzilidene)cyclohexanone by external stimuli Network reaction of 2,6-bis(2-hydroxybenzilidene)cyclohexanone by external stimuli, JOURNAL OF PHOTOCHEMISTRY AND PHOTOBIOLOGY A-CHEMISTRY, Volume: 283, Pages: 22-28;
60. Pana, A.M., Stefan (cas.Furca), L.M., Bandur, G.N., Sfirloaga, P., Gherman, V.D. Silion, M., Popa, M., Rusnac, L.M. Novel Glycopolymers Based on d-Mannose and Methacrylates: Synthesis, Thermal Stability and Biodegradability Testing, JOURNAL OF POLYMERS AND THE ENVIRONMENT Volume: 21 Issue: 4 Pages: 981-994

61. Paulescu, M., Badescu, V., Dughir, C. New procedure and field-tests to assess photovoltaic module performance, *ENERGY*, Volume: 70, Pages: 49-57;
62. Paulescu M., Mares O., Paulescu E., Stefu N., Pacurar A., Calinoiu D., Gravila P., Pop N., Boata R., Nowcasting solar irradiance using the sunshine number, *Energy Conversion and Management*, Vol. 79, p. 690–697, 2014;
63. Pescaru, D., Curiac D.I., Ensemble based traffic light control for city zones using a reduced number of sensors”, *Transportation Research Part C: Emerging Technologies*, Elsevier, Vol. 46, September 2014, pp. 261–273;
64. Pescaru, D., Curiac D.I., Anchor Node Localization for Wireless Sensor Networks Using Video and Compass Information Fusion, *Sensors*, Vol. 14(3), MDPI Basel, March 2014, pp. 4211–4224;
65. Motapon O, Pop N., Argoubi F, Mezei J, Epee MDE, Faure A, Telmini M, Tennyson J, Schneider IF, Rotational transitions induced by collisions of HD⁺ ions with low-energy electrons”, *PHYSICAL REVIEW A*, 90(1), 2014, 012706-1; 012706-9;
66. Pop N., Pacurar A., Boata, R., Gravila, P., Paulescu M. The assessment of beam solar irradiance using parametric modeling”, *International Journal of Green Energy*, Volume: 11, Issue: 8, Pages: 876-885;
67. Precup, R.E., David, R.C., Petriu, E.M., Radac, M.B., Preitl, S. Adaptive GSA-Based Optimal Tuning of PI Controlled Servo Systems With Reduced Process Parametric Sensitivity, Robust Stability and Controller Robustness, *IEEE TRANSACTIONS ON CYBERNETICS*, Volume: 44 Issue: 11, Pages: 1997-2009, Special Issue: SI;
68. Precup, R.E., Filip, H.I., Radac, M.B., Petriu, E.M., Preitl, S., Dragos, C.A. Online identification of evolving Takagi-Sugeno-Kang fuzzy models for crane systems, *APPLIED SOFT COMPUTING*, Volume: 24, Pages: 1155-1163;
69. Precup, R.E., Tomescu, M.L., Dragos, C.A. Stabilization of Rössler chaotic dynamical system using fuzzy logic control algorithm, *INTERNATIONAL JOURNAL OF GENERAL SYSTEMS*, Volume: 43, Issue: 5, Pages: 413-433;
70. Radac M. B., Precup, R. E., Petriu, E. M., Preitl, S. Iterative Data-Driven Tuning of Controllers for Nonlinear Systems with Constraints, *IEEE Transactions on Industrial Electronics*, vol. 61, no. 4, pp. 6360-6368, 2014;
71. Radu, A.G. Nonlinear reduced order modeling of isotropic and functionally graded plates, *INTERNATIONAL JOURNAL OF NON-LINEAR MECHANICS*, Volume: 49 Pages:100-110;
72. Raduca, M., Hatiegan, C., Pop, N., Raduca, E., Gillich, G.R. Finite element analysis of heat transfer in transformers from high voltage stations, *JOURNAL OF THERMAL ANALYSIS AND CALORIMETRY*, Volume: 118, Issue: 2, Pages: 1355-1360;
73. Rus, S.F., Vlazan, P., Herklotz, A. Effect of non-magnetic ion substitution on the magnetoelastic properties of CoFe₂O₄ films, *JOURNAL OF APPLIED PHYSICS*, Volume: 116, Issue: 1;
74. Vlazan, P., Rus, F.S., Vasile, E., Grozescu, I. Effect of the substitution element In in CoFe_{2-x}In_xO₄ on morphology, magnetic and optical properties, *PHYSICA SCRIPTA*, Volume: T157, Article Number: 014047;
75. Rus, F.S., Vlazan, P. Effect of non-magnetic ion substitution on the magnetoelastic properties of CoFe₂O₄ films, *JOURNAL OF APPLIED PHYSICS* Volume: 114, Issue: 4, Article Number: 043913;
76. Sarbu, I., Nodal analysis of urban water distribution networks, *WATER RESOURCES MANAGEMENT*, vol. 28, no. 10, 2014;

77. Sarbu, I., Sebarchievici, C. General review of ground-source heat pump systems for heating and cooling of buildings, *ENERGY AND BUILDINGS*, vol. 70, no. 2, 2014;
78. Sarbu, I. Sebarchievici, C. Aspects of indoor environmental quality assessment in buildings, *ENERGY AND BUILDINGS*, Volume: 60, Pages: 410-419;
79. Savu, I.D., Savu, S.V., Sirbu, N.A. Heat affected zones in polymer laser marking, *JOURNAL OF THERMAL ANALYSIS AND CALORIMETRY* Volume: 115, Issue: 2, Pages: 1427-1437;
80. Stoia, M., Barvinschi, P., Barvinschi, F. Structural and morphologic characterization of zirconia-silica nanocomposites prepared by a modified sol-gel method, *JOURNAL OF CRYSTAL GROWTH*, Volume: 401, Pages: 462-468;
81. Serban, V.A., Codrean, C., Voda, M., Chicot, D., Decoopman, X. Correlation between yield stress and hardness of nickel-silicon-boron-based alloys by nanoindentation, *MATERIALS SCIENCE AND ENGINEERING A-STRUCTURAL MATERIALS PROPERTIES MICROSTRUCTURE AND PROCESSING*, Volume: 605, Pages: 294-300;
82. Tigan, G., Analysis of a two-dimensional nonsmooth Poincaré-like map, *NONLINEAR DYNAMICS*, Volume: 75, Issue: 4, Pages: 643-651;
83. Tirian, G.O., Filip, I., Prostean, G. Adaptive control system for continuous steel casting based on neural networks and fuzzy logic, *NEUROCOMPUTING*, Volume: 125, Pages: 236-245, Special Issue: SI;
84. Todut, C., Dan, D., Stoian, V. Theoretical and experimental study on precast reinforced concrete wall panels subjected to shear force, *ENGINEERING STRUCTURES* Volume: 80, Pages: 323-338;
85. Totorean, A.F., Bosioc, I.A., Bernad, S.A., Susan-Resiga, R.F. Identification and visualization of vortices in by-pass graft flow, *PROCEEDINGS OF THE ROMANIAN ACADEMY SERIES A-MATHEMATICS PHYSICS TECHNICAL SCIENCES INFORMATION SCIENCE* Volume: 15, Issue: 1, Pages: 52-59;
86. Tutelea, L.N., Boldea, I.G. 2/4-POLE Split-Phase Capacitor Motor for Small Compressors: A Comprehensive Motor Characterization, *IEEE TRANSACTIONS ON INDUSTRY APPLICATIONS* Volume: 50, Issue: 1, Pages: 356-363;
87. Vatau, D., Musuroi, S., Barbulescu, C., Babescu, M. PV systems modelling and optimal control, *ENERGY CONVERSION AND MANAGEMENT*, Volume: 84, Pages: 448-456;

Projects supported by public funds

Research Projects

Field	Total number of projects	Source of financing	Number of projects
Automation and Computers	10	National Funds* International Programs**	9 1
Electrical and Power Engineering	1	National Funds*	1
Electronics and Telecommunications Engineering	6	National Funds* International Programs** POSDRU***	2 3 1
Chemical Engineering	9	National Funds*	9
Civil Engineering	10	National Funds* International Programs**	6 4
Materials Engineering	5	National Funds* International Programs**	4 1
Mechanical Engineering	14	National Funds* International Programs** POSDRU*** Cross-border Cooperation RO-SR	10 2 1 1
Engineering and Management	1	National Funds*	1
Mathematics	2	National Funds* International Programs**	1 1

* National Funds - funds awarded by the Romanian govern through UEFISCDI

** International Programs - EU 7th Framework Program, Research Fund for Coal and Steel or the Information and Communication Technologies Policy Support Program - The European Space Agency (ESA)

*** Structural Funds - European Regional Development Fund, European Social Fund and the Romanian National Authority for Scientific Research

Project in highlight

FULL-SCALE EXPERIMENTAL VALIDATION OF DUAL ECCENTRICALLY BRACED FRAME WITH REMOVABLE LINKS (DUAREM)

Goal of the project

The aim of the project was to reduce the repair costs and downtime of a structure hit by an earthquake. There are three main objectives: (a) validate experimentally the re-centring capability of dual structures with removable dissipative members; (b) assess overall seismic performance of dual eccentrically braced frames; (c) obtain information on the interaction between the steel frame and the reinforced concrete slab in the link region and (d) validate the link removal technology.

Short description of the project

Improved seismic performance of multi-storey structures is to be attained through removable dissipative members ("fuse components") and re-centring capability. The concepts of removable dissipative members and re-centring capability are to be implemented in a dual structure, obtained by combining steel eccentrically braced frames with removable bolted links with moment resisting frames.

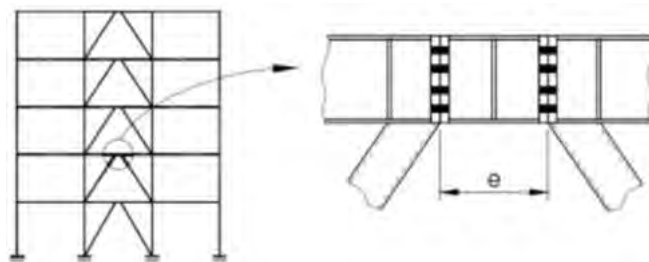

The bolted links are intended to provide the energy dissipation capacity and to be easily replaceable, while the more flexible moment resisting frames would provide the necessary re-centring capability to the structure. The columns are to be realised from high strength steel, in order to keep these members in the elastic range even under strong seismic input. The validation of the proposed solution is to be realised through a pseudo-dynamic test of a full-scale model of a dual eccentrically braced structure at the European Laboratory for Structural Assessment (ELSA) of the Joint Research Centre (JRC) in Ispra, Italy. The research will demonstrate the feasibility of the proposed concept clearing the route toward implementation into design.

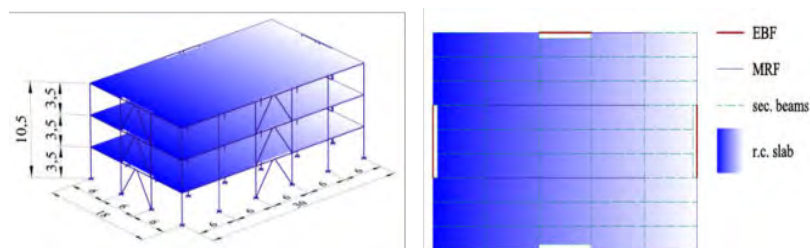

The main lateral load resisting system of the prototype structure is composed of eccentrically braced frames. Additionally, there are 4 moment resisting frames on transversal directions and 10 moment resisting frames on longitudinal (test) direction, to assure the restoring forces after an earthquake. Considering that in the transversal direction the lateral force resisting system is located on the perimeter frames only, and in order to reduce the cost of the experimental specimen, it was composed of the two perimeter frames only.

Steel structural components were designed in S355 grade steel, with two exceptions. Grade S460 steel was used for columns, in order to obtain a larger capacity without increasing the stiffness. This approach helps promoting the capacity design rules. Links were designed from S235 steel grade (which was replaced during fabrication with equivalent DOMEX 240 YP B) mainly due to coping with available actuator capacities.

The floor layout is conceived in a manner that allows investigation of two different solutions of interaction between the removable link and the reinforced concrete slab. One of the two eccentrically braced frames is realised so that the beam containing the removable link is totally disconnected from the reinforced concrete slab (the south frame) and in the other EBF the beam containing removable links is connected to the slab in a conventional way (the north frame).

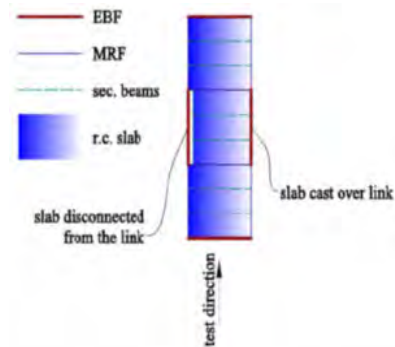

The structure showed an excellent seismic performance. The large scale experimental programme validated the procedure used to remove and replace damaged shear links in dual eccentrically braced frame. Small permanent deformations were recorded until the ultimate limit state earthquake level, which means that the structure is to a certain degree self-centring. Nevertheless, permanent drifts were eliminated further through removal of bolted links. Very good re-centring for frame with links disconnected from the slab was observed and only moderate cracks in the slab on the other frame were noticed (until the ultimate limit state).

If permanent plastic deformations after an earthquake are small, removing of shear links can be done simply by unbolting. If larger permanent drifts occur, as could be the case under near-field records or long-period motions, flame cutting of links and temporary braces for smooth release of forces could be employed. The system combining "fuse" components with re-centring capacity may also be extended to buckling restrained braced (BRB) and steel plate shear walls (SPSW) systems.

Project implemented by

CESMIG – The Research Centre for Mechanics of Materials and Structural Safety – Research and Technical Development unit of Politehnica University Timisoara, at the Faculty of Civil Engineering, Department of Steel Structures and Structural Mechanics.

Research Team

- UPT – Politehnica University of Timișoara, Romania (project coordinator)
- University of Liege, Belgium
- University of Naples "Federico II" – Faculty of Architecture, Italy
- University of Ljubljana, Slovenia
- University of Coimbra, Portugal

Main activities

According to the flowchart of research, the main activities can be summarized as follows:

- The prototype structure was designed according to EN1990, EN1991, EN1992, EN1993, EN1994 and EN1998;
- Numerical simulations on the test structure and links were done in order to investigate the possibility to replace bolted links following significant inelastic deformations and the practical feasibility of the replacement procedure;
- Practical solutions regarding order in which bolted links need to be replaced were developed;
- A solution that uses temporary braces with viscous dampers mounted on the structure during link removal was analysed and chosen in order that the link removal process to be a safe one;

- Some experimental tests on one-storey one-span frames were used in order to calibrate the numeric model of the DUAREM test structure, before applying the link removal procedure;
- The testing sequence on the mock-up in the reaction wall facility of ELSA consists in modal evaluation, snap-back and pseudo-dynamic tests.
- The two frames of the specimen were instrumented in order to obtain information on the structural behaviour during the seismic tests, performed by using the pseudo-dynamic test method. The instrumentation consists of local displacement transducers (to monitor the links deformations and the slip in the splice connection of every EBF brace and the EBF beams from the 1st storey, in the south frame), global displacement transducers (to monitor the global longitudinal and transversal displacements of the structure), inclinometers (to monitor the rotations of the beam to column and column base joint zones) and strain gages (to monitor the yielding at the middle of the EBF braces and at the end of the MRFs beams at the 1st storey).
- Pre-test nonlinear dynamic simulations were performed on the 2D model of the experimental mock-up, using seven ground motion records, selected by matching the elastic response spectrum used in design. One record was chosen to be used in the pseudo-dynamic tests in order to evaluate the structural performance of the test structure, applied with several input levels:

Limit state	Return period, years	Probability of exceedance	a_0/a_{gr}	a_0/g
Full Operation (FO)	-	-	0.062	0.020
Damage Limitation (DL / SLS)	95	10 % / 10 years	0.59	0.191
Significant Damage (SD / ULS)	475	10 % / 50 years	1.00	0.324
Near Collapse (NC)	2475	2 % / 50 years	1.72	0.557

The following pseudo-dynamic tests were proposed and performed:

- DL/SLS (Damage Limitation/Serviceability Limit State) tests set:
 - Full operation (FO1) earthquake ($a_g=0.02g$);
 - Damage Limitation (DL/ SLS) earthquake ($a_g=0.191g$).
- SD/ULS (Significant Damage/Ultimate Limit State) tests set:
 - Full operation (FO2) earthquake ($a_g=0.02g$);
 - Significant Damage (SD/ULS) earthquake ($a_g=0.324g$);
 - Pushover (PO1) test (monotonic, with a displacement of 55 mm).
- NC (Near Collapse) tests set:
 - Full operation (FO3) earthquake ($a_g=0.02g$);
 - Near collapse (NC) earthquake ($a_g=0.557g$);

Results

The first tests, the snap back tests, were carried out by imposing and releasing (at a very short time interval) a force at the first floor of the north frame to simulate the last seismic link removal, were according to numerical simulation is were the highest forces are locked into the device. This was achieved by pulling the structure towards the reaction wall with a piston linked by a notched bar that gave the sudden release of force when breaking after reaching its maximum. The force achieved during the snap back was lower than that given by the numerical simulation, and limited to prevent damage on the structure.

The proposed pseudo-dynamic tests, as well as two link replacement operations, were performed and information about the seismic performance of the test specimen, the link replacement feasibility and concrete slab influence were obtained.

DL/SLS tests set results:

- FO1 test was performed in order to assess the elastic response of the structure with the initial (first) set of links, the selected seismic record being scaled to have the PGA of 0.02g. During this first test, the structure manifested an elastic response, in the non-dissipative elements, as well as in the dissipative ones (including the links). This means that there were no residual top displacements or inter-storey drifts of the structure, the maximum top displacement being also small.

- DL/SLS test was performed afterwards, in order to simulate a moderate earthquake, causing moderate structural damage, the selected seismic record being scaled to have the PGA of 0.191g. During this test, no yielding was observed in the elements outside links. Small maximum plastic deformations occurred in links and no slips have occurred in the EBF braces and beams splice connections. Beam to column and column bases joint zones manifested small rotations. Minor cracks were observed in the concrete slab. The structure exhibited low residual top displacement. Also low residual inter-storey drifts were observed.

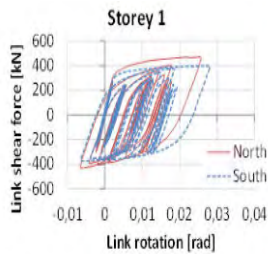
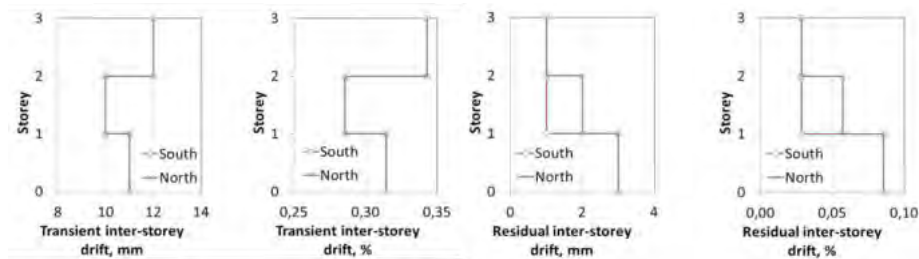

First link replacement (LR1):

- Because after the DL/SLS test the structure exhibited low residual top displacement and low residual drifts were observed, the decision was to remove the first set of damaged links, by removing the bolts, on a level by level basis, starting from the lower level to the upper one. The low value of the residual top displacement from the end of the DL/SLS test decreased after the elimination of the damaged links. A better re-centring was observed in the south frame, where the concrete slab is disconnected from the link. After unscrewing the bolts, a hydraulic jack had to be used for pushing apart the braces, in order to pull out the links. A new set of unused links was then mounted into the structure.

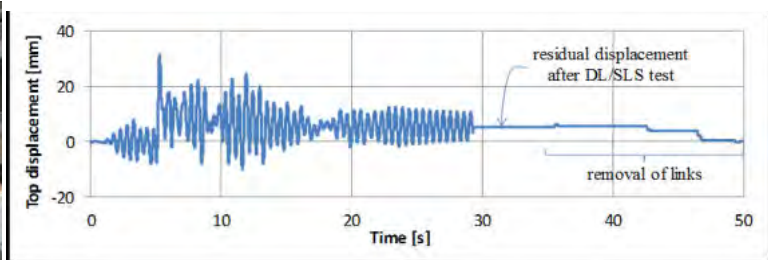

SD/ULS tests set results:

- F02 test was performed in order to assess the elastic response of the structure with the new (second) set of links, the selected seismic record being applied with a scaling factor of 0.02. During this second FO test, the structure exhibited a similar behaviour as the FO1 test. This means that the structure manifested an elastic response, in the non-dissipative elements, as well as in the dissipative ones (including the links) and there were no residual top displacements or inter-storey drifts of the structure, the maximum top displacement being also small.
- SD/ULS test was performed in order to simulate a stronger earthquake, causing larger structural damage, the selected seismic record being scaled to have the PGA of 0.324g. During this test, no yielding was observed in the elements outside links. Moderate maximum plastic deformations occurred in links and no slips have occurred in the EBF braces and beams splice connections. Beam to column and column bases joint zones manifested slightly larger rotations. Moderate cracks were observed in the concrete slab. The structure exhibited still quite low residual top displacement.
- Also low residual inter-storey drifts were observed.

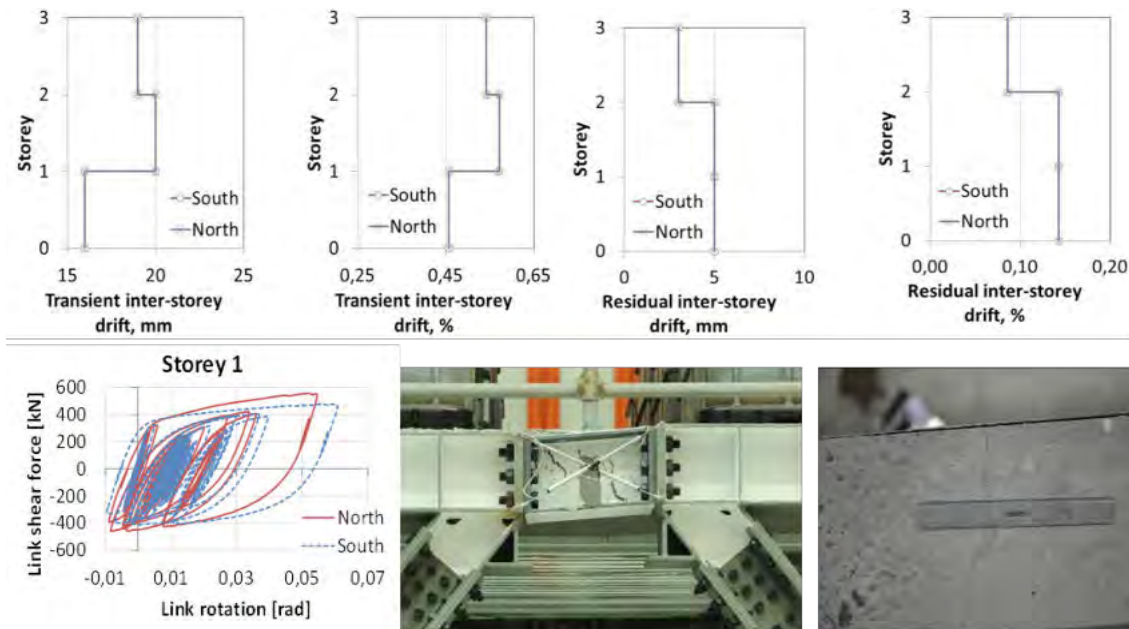

- PO1 test (a monotonic pushover test until an additional displacement of 55 mm) starting from the end of the SD/SLS test position was necessary. This was done to obtain larger residual displacements that were necessary in order to validate the feasibility of the link removal process and re-centring of the structure. During this test, no yielding was observed in the elements outside links. Higher maximum plastic deformations occurred in links and no slips have occurred in the EBF braces and beams splice connections. Beam to column and column bases joint zones manifested larger rotations. More visible cracks were observed in the concrete slab. After this test, the structure exhibited significant larger residual top displacement. Larger residual inter-storey drifts amounting were observed.

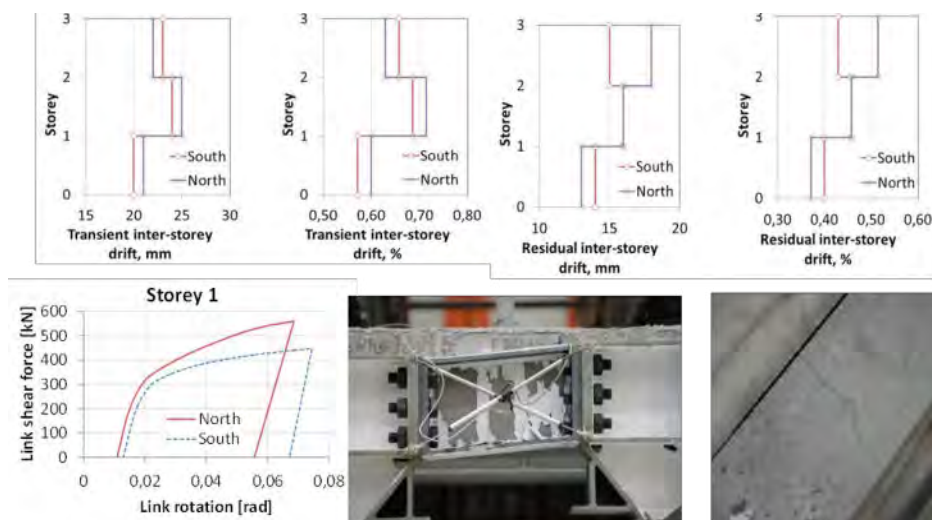

Second link replacement (LR2):

- Because after the PO1 test the structure exhibited significant larger residual top displacement and larger residual drifts were observed, the decision was to remove the second set of damaged links, by flame cutting both the web and flanges of the links, from the top storey downwards. The value of the residual top displacement from the end of the PO1 test was decreased after the elimination of the damaged links. Again a better re-centring was observed in the south frame, where the concrete slab is disconnected from the link. Although the hydraulic jack was not necessary to remove the links, it was needed for placing the new set of links back into the structure. A new set of unused links was then mounted into the structure.

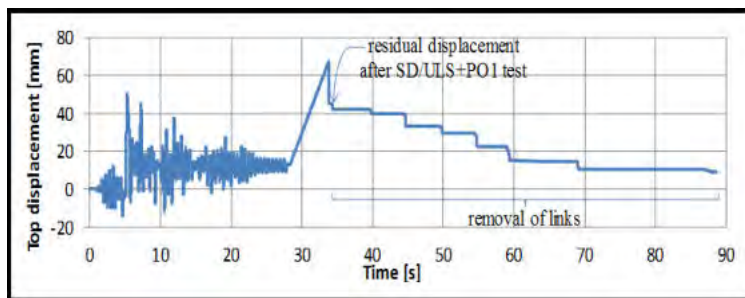

NC tests set results:

- TF03 test was performed in order to assess the elastic response of the structure with the new (third) set of links, the selected seismic record being scaled to have the PGA of 0.02g. During this third FO test, the structure exhibited a similar behaviour as the first two FO tests. The structure manifested an elastic response, in the non-dissipative elements, as well as in the dissipative ones outside links and very small residual deformations in links and there were no residual top displacements or inter-storey drifts of the structure, the maximum top displacement being also small.
- NC test was proposed in order to simulate a much stronger earthquake and to obtain extensive damage throughout the structure, the re-centring capability being lost due to yielding in other members apart from the links, the selected seismic record being applied with a scaling factor of 0.557. This test was prematurely stopped because the available actuator capacity (1000 kN per frame at every floor) was not enough to carry it out with the imposed null torsion at every floor.
- Another cyclic pushover test (PO2) with maximum displacement amplitudes of 150 mm was further proposed, after the actuators' release of force from the NC test and afterwards a final cyclic pushover test (PO3) with maximum displacement amplitude of 400 mm.
- The last three tests brought extensive plastic behaviour throughout the entire structure. First of all, very large maximum plastic deformations occurred in links, failure occurring in the welds of the links to the end plates and also between web and flanges for the first two levels. Significant damage was also observed in the column bases zones and at the end of the MRFs beams (strains 3 times larger than the yield one), just outside the haunch. Beam to column and column bases joint zones manifested very large rotations. The concrete slab was heavily deteriorated in the north frame.



- Due to the presence of the slab over the links, the north frame is more rigid and has a larger capacity than the south frame. This makes more difficult the re-centring of the north frame with respect to the one of the south frame, but the residual drifts were still lower than the erection tolerances.
- The dual eccentrically braced structure showed an excellent performance at the SLS and ULS earthquakes. Small permanent deformations were recorded for both seismic intensity levels, which are within the erection tolerance limits defined in EN 1090. This behaviour occurs mostly due to the large post-elastic stiffness of the system, provided by the moment-resisting frames. Small permanent deformations effectively mean that the structure is self-centring to a certain degree.

Implementation period

01.06.2010 – 01.08.2014

Applicability and transferability of the results:

After the pseudo-dynamic experimental validation of the main concepts, the experimental results interpretation and numerical model validation and calibration, the system can be applied to new, higher, multi-storey steel dual structures in seismic areas. A design methodology for dual eccentrically braced steel frames with removable links thus can be developed, as well as a guide for link replacement technology. The system may also be extended to buckling restrained braced (BRB) and steel plate shear walls (SPSW) systems.

Fields of interest

- Re-centring structures; Performance-based design; Bolted link connections; Pseudo-dynamic structural experimental tests.

Financed through/by

- European Community's Seventh Framework Programme [FP7/2007–2013] for access to the European Laboratory for Structural Assessment of the European Commission – JRC under grant agreement n° 227887
- European Community's Research Fund for Coal and Steel under grant agreement n° RFSR-CT-2009-00024 "High strength steel in seismic resistant building frames"

Research centre

CEMSIG - The Research Centre for Mechanics of Materials and Structural Safety,
Politehnica University of Timisoara.

Dissemination of results:

- Dubina, D., Stratan, A., Dinu, F. (2011). "Re-centring capacity of dual-steel frames", *Steel Construction: Design and Research*, Vol. 4, No. 2, pp. 73-84.
- Ioan, A. (2011). "Seismic response of dual steel eccentrically braced frames with removable links". *Scientific Journal - Mathematical Modelling in Civil Engineering*, vol.7, no.4, ISSN 2066 – 6926, pp. 101- 110 – BDI Journal.
- Stratan, A., Ioan, A., Dubina, D. (2012). "Re-centering capability of dual eccentrically braced frames with removable bolted links". *Proceedings of the 7th International Conference on Behavior of Steel Structures in Seismic Areas (STESSA)*, 9-11 January 2012, Santiago, Chile, ISBN 978-0-415-62105-2, pp. 723-728 – ISI Web of Knowledge conference.
- Ioan, A., Stratan, A., Dubina, D., Taucer, F. (2012) – "Dual Steel Eccentrically Braced Frames with Bolted Links – Simulation of Safe Removal Process". *Proceedings of the First International Conference for PhD students in Civil Engineering (CE-PhD)*, 4-7 November 2012, Cluj-Napoca, Romania, ISBN 978-973-757-710-8, pp. 220-227.
- Ioan, A., Stratan, A., Dubina, D. (2013). "Numerical Simulation of bolted links removal in eccentrically braced frames". *Pollack Periodica*, vol. 8, no.1, ISSN 1788-1994, pp. 15-26 – BDI Journal.
- Dubina, D., Stratan, A., Florea, D., Ioan, A. (2013). "Sisteme structurale cu componente disipative de siguranta seismica" (in Romanian). *AICPS Review*, no. 1-2 ISSN 2067-4546, pp. 41-50.
- Stratan, A., Ioan, A., Dubina, D., D'Aniello, M., La Manna Ambrosino, G., Landolfo, R., Taucer, F., Poljansek, M. (2013). "Pre-test numerical simulation and experimental program on a dual eccentrically braced frame with replaceable links". "XXIV Giornate italiane della Costruzione in Acciaio", Torino, 30 September – 2 October 2013, ISBN 978-88-905870-0-9, pp. 867-876.
- Ioan, A. (2013). "Pre-testarea numerica a unui cadru cu bare disipative demontabile supus la incercari pseudo-dinamice" (in Romanian). *AICPS Review*, no. 3, ISSN 2067-4546, pp. 63-71. (ZAT2013)
- Ioan, A., Stratan, A., Dubina, D. "Evaluation of restoring capacity of dual steel EBFs with removable links". *Pollack Periodica* (accepted for publication)
- Stratan, A., Ioan, A., Dubina, A., Taucer, F., Poljansek, M. (2013). "Pre-test numerical simulations and experimental program on dual eccentrically braced frame with removable links". *International Workshop "High Strength Steel in Seismic Resistant Structures - HSS-SERF"* 28-29 June 2013, Naples, Italy, ISBN 978-973-638-552-0, pp. 137-148.
- Stratan, A., Ioan, A., Dubina, D., Taucer, F., Poljanšek, M., Molina, J., Pegon, P., D'Aniello, M., Landolfo, L. 2014. „Experimental program for large-scale tests on a re-centring dual eccentrically braced frame”. *EUROSTEEL 2014 (7th European Conference on Steel and Composite Structures)*, 10-12 September 2014, Napoli, Italy.
- Ioan, A., Stratan, A., Dubina, D. 2014. „Link replacement order in high-rise re-centring dual eccentrically braced frames”. *EUROSTEEL 2014 (7th European Conference on Steel and Composite Structures)*, 10-12 September 2014, Napoli, Italy.
- Stratan, A., Ioan, A., Dubina, D., Poljanšek, M., Molina, J., Pegon, P., Taucer, F. (2014). „Dual eccentrically braced frames with removable links: Experimental validation of technical solution through large-scale pseudo-dynamic testing”. *5CNIS&1CNISS (5th National Conference of Earthquake Engineering and 1st National Conference on Earthquake Engineering and Seismology)*, 19-20 June 2014, Bucharest, Romania.
- Stratan, A., Ioan, A., Dubina, D., Poljanšek, M., Molina, J., Taucer, F., Pegon, P., Sabau, G. (2014). "Experimental validation of re-centring capacity of eccentrically braced frames with removable links" – sent to *Engineering Structures Journal - ISI Web of Knowledge journal*.

Contact information

Prof. Dr. H. C. Dan DUBINĂ, PhD
 Corresponding Member of Romanian Academy
 Department of Steel Structures and Structural Mechanics
 Address: Str. Ioan Curea, No. 1, RO300224, Timisoara
 Phone: (+40) 256 403 920
 Fax: (+40) 256 403 917
 E-mail: dan.dubina@upt.ro

CONTROL ALGORITHMS AND OPTIMAL TUNING OF FUZZY MODELS FOR AUTOMOTIVE, MECHATRONICS APPLICATIONS AND MOBILE ROBOTS

Goal of the project

Development of control structures and algorithms and optimal tuning of fuzzy models for a wide range of industrial processes, mechatronics, mobile robots and automotive applications.

Short description of the project

The project aims:

- Advanced control structures for automotive and mechatronics applications.
- Improvement and development of new Takagi-Sugeno (T-S) fuzzy models and control solutions for a wide range of industrial processes.
- Optimal tuning of fuzzy models for automotive and mechatronics applications.
- Improvement and development of control algorithms for mobile robots.

Project implemented by

"Gheorghe Asachi" Technical University of Iasi (TUIASI) – Coordinator;
Politehnica University of Timisoara, Department of Automation and Applied Informatics – Project Partner P1;
S.C. ROMUS Trading & Development SRL – Project Partner P2.

Implementation period

2012-2016

Main activities

- Design of low-cost T-S state feedback fuzzy controllers for the position control of a class of nonlinear servo systems.
- Sensitivity analysis with respect to the process parametric variations in the low-cost controller designs for vehicle power train systems with spark-ignition engine and continuously variable transmission.
- Modelling, simulation, analysis and design of linear, fuzzy and variable structure control solutions for direct current electric drive systems with continuously variable reference input, variable moment of inertia and variable load disturbance input, applicable to rolling mills and to strip winding systems.
- Development and experimental validation of simple T-S fuzzy models for several processes in automotive and mechatronics: anti-lock braking systems, nonlinear DC drive servo systems, magnetic levitation systems, electromagnetic actuated clutch systems, inverted pendulums.
- Fuzzy logic control algorithms that stabilize chaotic dynamical systems.

- Frequency domain design of fractional order proportional-integral controllers for lambda control in the framework of automotive engine control systems.
- Development of two-degree-of-freedom linear and fuzzy controllers, of hybrid T-S fuzzy controllers, of hybrid PI neuro-fuzzy controllers and of adaptive sliding mode fuzzy controllers for speed and position control of brushless DC drives with variable parameters – continuously variable reference input (speed), variable moment of inertia and variable load disturbance.
- Optimal tuning of parameters of T-S fuzzy models using nature-inspired algorithms (simulated annealing, particle swarm optimization and gravitational search algorithms) and evolving fuzzy modelling.
- Continuous development of the nRobotic platform in the framework of path planning and collision avoidance for mobile robots in missions.
- Development and testing of path planning algorithms for mobile robots using nature-inspired optimization algorithms.

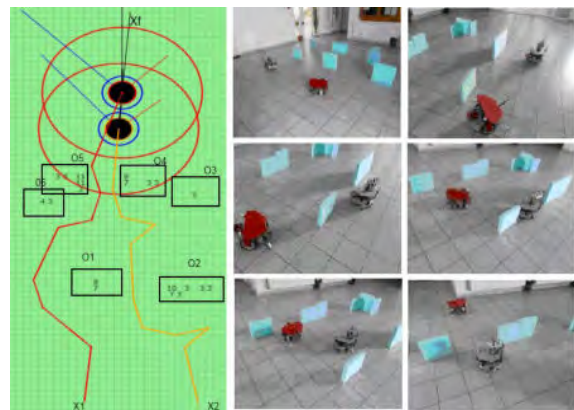

Results

- 20 papers published in ISI journals with impact factors.
- 3 papers published in journals indexed by international databases.
- 7 book chapters published in Springer-Verlag volumes.
- 20 papers published in conference proceedings indexed by international databases (IEEE Xplore, INSPEC, DBLP, Scopus).
- more than 50 independent citations in 2014.

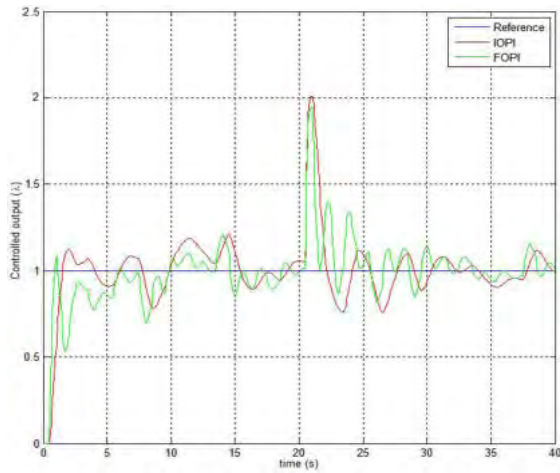

Applicability and transferability of the results

Nature-inspired optimization algorithms in modelling and control design, low-cost solutions for control problems in mechatronics, electrical drives, automotive and robotics, tools for the modelling, optimization and design of fuzzy control systems, real-time programming and operating systems for control and robotics.

Financed through/by

Executive Agency for Higher Education, Research, Development and Innovation Funding – UEFISCDI, Bucharest, Romania.

Research Centre

CCISA - Research Centre for Automatic Systems Engineering

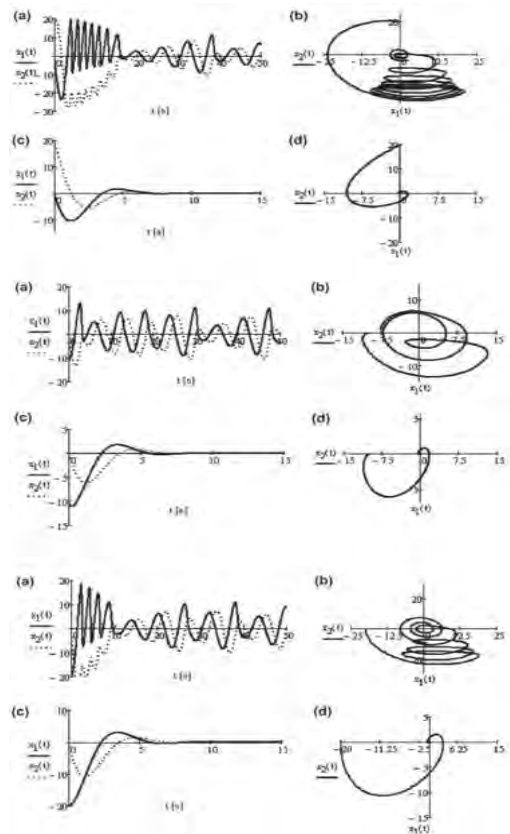
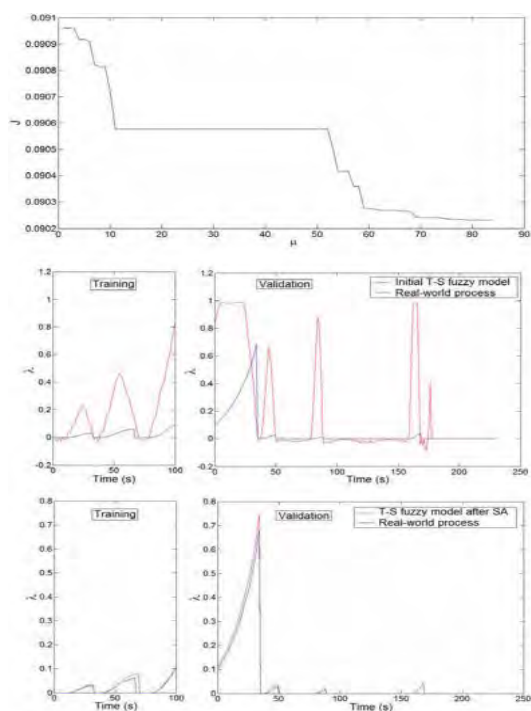

Research team

Prof. Dr. Ing. Radu-Emil Precup – director
 Prof. Dr. Ing. Stefan Preitl
 Prof. Dr. Ing. Ioan Filip
 Assoc. Prof. Dr. Ing. Florin Drăgan
 Lect. Dr. Ing. Adriana Albu
 Lect. Dr. Ing. Ovidiu Baniș
 Lect. Dr. Ing. Daniel Ierican
 Assist. Lect. Dr. Ing. Claudia-Adina Dragoș
 Assist. Lect. Dr. Ing. Mircea-Bogdan Rădac
 Dr. Ing. Alexandra-Lulia Stînean
 PhD student M.Sc. Ing. Lucian-Ovidiu Fedorovici
 PhD student M.Sc. Ing. Constantin Purcaru

Contact information

Prof. Radu-Emil PRECUP, PhD
 Director of the CCISA Research Centre
 Department of of Automation and Applied Informatics
 Address: Str. Bd. Vasile Pârvan, No. 2, RO300223, Timisoara,
 Phone: (+40) 256 403 229
 Fax: (+40) 256 403 214
 E-mail: radu.precup@upt.ro
 Web: <http://www.aut.upt.ro/centru-cercetare/index.EN.php>

NEW PERFORMANCE IMPROVEMENT TECHNIQUES OF CONTROL SYSTEMS USING EXPERIMENT-BASED TUNING

Goal of the project

Enhance the existing techniques and develop new techniques dedicated to the improvement of control system performance using experimental data.

Short description of the project

The project aims:

- Enhancement and development of data-based (data-driven) techniques and algorithms for improving control system performances using experimental data.
- Enhancement and development of nature-inspired algorithms in optimization of control system performance.
- Development of optical character recognition (OCR) applications.
- Development of new fuzzy control solutions for a wide range of industrial processes.

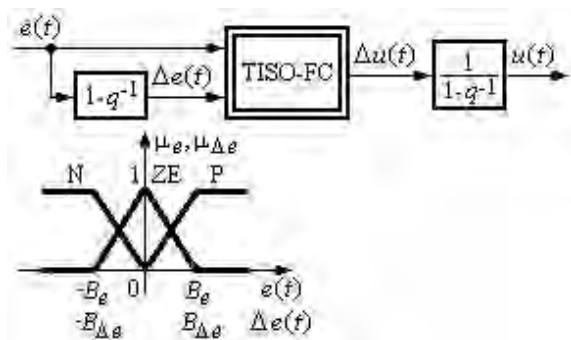

Project implemented by

Department of Automation and Applied Informatics.

Implementation period

2011-2015

Main activities

- Application of Iterative Feedback Tuning (IFT) and Simultaneous Perturbation Stochastic Approximation (SPSA) to state-feedback optimal control with Kalman filter state observers.
- Application of stable Iterative Correlation-based Tuning to servo systems.
- An experiment-based approach to Reference Trajectory Tracking optimal control problem.
- Validation of iterative techniques on laboratory equipment such as: liquid level control, motion control systems with motor actuation (speed and position control, inverted pendulum).

- Enhancement of control systems performance by fuzzy control and IFT.
- Enhancement of existing nature-inspired algorithms such as Gravitational Search Algorithm (GSA) and Charged System Search (CSS).
- PI and fuzzy controller tuning to ensure a reduced sensitivity with respect to the parametric variations of processes.
- Enhancement of the training algorithm of Convolutional Neural Networks using a mixed approach of Back-Propagation and Gravitational Search Algorithm.
- Development of telesurgical applications and control of telerobots in space medicine,
- Control of nonlinear discrete-time MIMO systems.
- Application of IFT for controller tuning to nonlinear processes in constrained environments using neural networks.
- Application of model-free Iterative Learning Control to the control of repetitive processes in constrained environments.

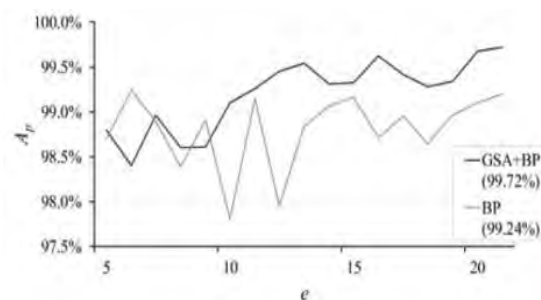

Results (overall 2011-2014)

- 26 papers (ISI) published in journals with impact factors, cumulated impact factor according to 2013 Journal Citation Reports (JCR) released by Thomson Reuters in 2014 = 51.240, cumulated relative influence score = 32.889.
- 1 journal paper indexed by international database (Zentralblatt Math).
- 7 book chapters published in Springer-Verlag volumes.
- 17 papers published in conference proceedings indexed by Thomson Reuters Web of Science.
- 18 papers published in conference proceedings indexed by international databases (IEEE Xplore, INSPEC, DBLP, Scopus).

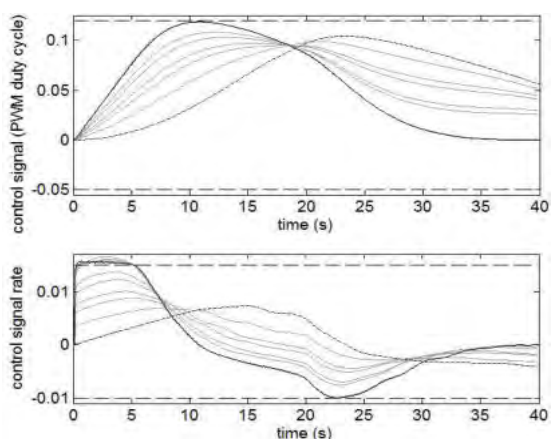
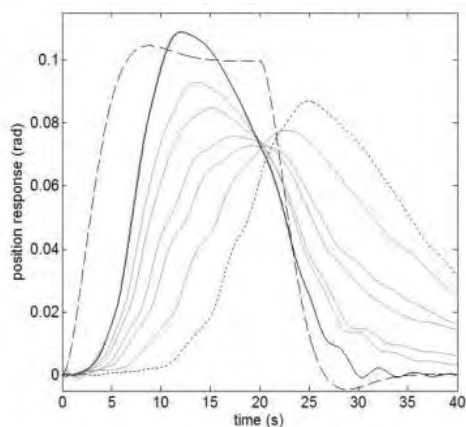
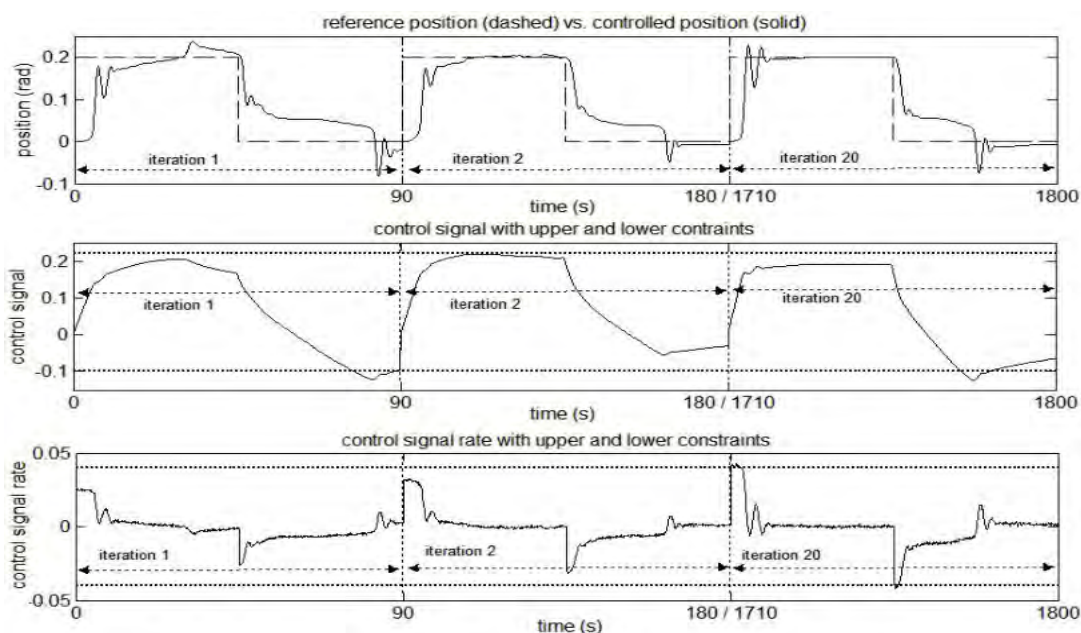

Research centre

Research Centre for Automatic Systems Engineering (CCISA)

Applicability and transferability of the results

Control systems with a reduced parametric sensitivity, tools for the computer-aided design of controllers, computer-aided techniques in iterative data-based control, nature-inspired optimization algorithms in control design and image processing, tools for the systematic development of fuzzy control systems.

Financed through/by

Executive Agency for Higher Education, Research, Development and Innovation Funding (UEFISCDI), Bucharest, Romania.

Research team

Prof. Radu-Emil PRECUP, Ph.D
 Prof. Stefan PREITL, Ph.D
 Assoc. Prof. Florin DRAGAN, Ph.D
 Assist. Lect. Daniel IERCAN, Ph.D
 Assist. Lect. Mircea-Bogdan RADAC, Ph.D
 Assist. Lect. Claudia-Adina DRAGOS, Ph.D
 Alexandra-Iulia STINEAN, Ph.D
 Lucian-Ovidiu Fedorovici - Ph.D. student

Contact information

Prof. Radu-Emil PRECUP, Ph.D
 Director of the CCISA Research Centre
 Department of Automation and Applied Informatics
 Address: Bd. Vasile. Pârvan, No. 2, RO300223 Timisoara,
 Phone: (+40) 256 403 229
 Fax: (+40) 256 403 214
 E-mail: radu.precup@upt.ro
<http://www.aut.upt.ro/centru-cercetare/index.EN.php>

HYBRID SYSTEMS FOR CONVERTING RENEWABLE ENERGY OF SMALL VOLTAGE INTEGRATED INTO A MICROGRID

Goal of the project

The project is focused on the research, development and testing of an intelligent and flexible (configurable) small scale power system based on integration of three renewable energy sources: wind, hydro, and solar (photovoltaic) power, adapted to the available resources in Romania, in various regions of the country, working independently or connected to the grid.

Short description of the project

The project will cover the entire power conversion structure, including the design of adequate prime movers and new types of generators and power electronic converters, storage devices, power flow management system and load control. Some configurable structures (wind, micro-hydro and PV, all or a part of them, including their integration in a microgrid) will be proposed as experimental models, ready to be transferred to industry. There are proposed novelty elements regarding: low power wind turbine with integrated overspeed protection system, new generators configurations, and new topologies for power electronic converters and microgrid structures, optimal local control strategies and intelligent power system management.

Project implemented by

Politehnica University of Timisoara – Project coordinator
 Technical University of Cluj-Napoca – Project partner
 SC EETIM SA – Project partner

Implementation period

2012–2016



Main activities

- Microgrid components modeling, simulation and design.
- Microgrid components manufacturing, individual testing and integration in the experimental setup.
- Design, implementation and validation of the control strategies for microgrid components.
- Design, implementation and validation of the microgrid control strategy.
- Results dissemination and know-how exchange



Results

- A new over-speed protection system for wind turbines.
- A new electrical reactive brushless dc generator with performances comparable with high energy PM generator, at low cost.
- A new RF-IPMSG with high efficiency, maintenance-free operation, and high-controllability.
- A new AF-PMSG optimized for modular design. A new multiphase inverter with adequate control for the proposed generators.
- New multi-input dc-dc converters with high efficiency.
- High power tandem inverters for load management.
- Hardware and software package for power management, power flow control, individual converter control, and MPPT and other control strategies.
- Experimental microgrid system with integrated photovoltaic, wind and hydro generation.
- Technical papers will be published in top international journals and conference proceedings



Applicability and transferability of the results

All the research results are the property of the project coordinator and its partners.

Financed through/by

Joint Applied Research Projects - Partnership in S&T priority domains financed by the Executive Agency for Higher Education, Research, Development and Innovation Funding (UEFISCDI).



Research centre

Research Centre for Automatic Systems Engineering.

Research team

Octavian PROSTEAN
Nicolae MUNTEAN
Nicolae BUDISAN
Ioan FILIP
Mircea BARGLAZAN
Stefan KILYENI
Ilarie BORDEASU
Teodor MILOS
Cristian VASAR
Iosif SZEIDERT-SUBERT
Lucian TUTELEA
Cristian LASCU
Sorin DEACONU
Gabriela PROSTEAN
Dan UNGUREANU
Andreea ROBU
Adrian BEJ
Radu BORACI
Octavian CORNEA
Ovidiu TIRIAN
Rodica BADARAU

Contact information

Prof. Octavian PROSTEAN, PhD
Department of Automation and Applied Informatics
Address: Bv. Vasile Pârvan, No. 2, RO300223, Timisoara
Phone: (+40) 256 403 225
Fax: (+40) 256 403 214
E-mail: octavian.prostean@upt.ro

ARTRAC - ADVANCED RADAR TRACKING AND CLASSIFICATION FOR ENHANCED ROAD SAFETY

Goal of the project

ARTRAC aims to develop an active safety system to protect vulnerable road users (VRUs) from vehicles in motion that is economically viable in the volume vehicle market. The safety system will consist of both actuators for controlling vehicle driving dynamics and the perception component for the vehicle's surroundings. It will be tested on two types of vehicles that pose the biggest hazard to VRUs in urban settings, namely cars and light delivery goods vehicles.

Short description of the project

- The environmental sensing used in ARTRAC project will be based on a single automotive 24 GHz narrowband radar sensor. This offers the potential to overcome the price barrier that has prevented VRU protection systems from entering widespread use. To meet the challenging technical requirements for very short measurement time, reliable target detection, ego motion and road condition estimation, a new transmit/receive antenna and multi-channel receiver will be developed.

Project implemented by

Consortium of seven institutions:

- 2 car manufacturers (VOLKSWAGEN, FIAT through CRF);
- 2 research organizations (VTT - Finland, CTAG - Spain);
- 2 universities (TUHH - Technical University Hamburg-Harburg, UPT - Politehnica University of Timișoara);
- one SME specialized in car sensors (SMS Germany).

Implementation period

November 2011 – October 2014

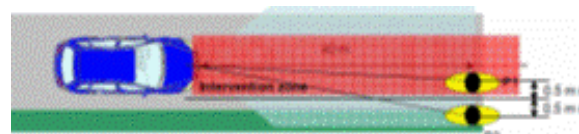

ARTRAC car radar technical specifications

Main activities

The whole system consisting of radar sensor, sensor fusion, risk assessment and vehicle control has a high potential to be launched because the majority of components is already standard equipment in series cars.

Measures for VRU protection might be divided into passive and active systems. Because of basic physical properties, passive measures can provide limited protection potential only. Therefore (active) actuators are necessary to achieve the desired protection for VRUs.

Vehicle deceleration seems to be a potential approach for active VRU protection with high benefit and high potential for high volume series cars, as they are already in use in high-end limousines.

The environmental sensing will be conducted with a novel high performance but low-cost 24 GHz narrowband radar system. From an operational viewpoint, this RF frequency fits exactly into the existing ISM band from 24,000 GHz to 24,250 GHz. Due to this techno-political feature this radar has a long term perspective on European and world-wide markets.

Results

ARTRAC addresses the following six major scientific and technical objectives:

- Develop a generic detection system able to detect pedestrians, cyclists, and other vulnerable road users (VRU) as well as vehicles.
- Implement the capability to monitor road surface conditions and detect low-friction road sections caused by water, ice or snow on asphalt, to warn or adapt the vehicle's electronic control systems such as electronic stability control (ESC) and collision avoidance systems (CAS) for changed friction conditions.
- Promote the deployment of VRU safety technologies among relevant bodies and stakeholders, including end-users.

Studies and papers developed by UPT research team for ARTRAC project in 2014

- Ioan NAFORNITA, Andrei CAMPEANU, Alexandru ISAR, Corina NAFORNITA, Adrian MACAVEIU – “Rapid Chirps”, “Road Condition Measurements”, “Tracking” – April 2014
- Adrian Macaveiu, Andrei Campeanu, Ioan Nafornita, Kalman-Based Tracker for Multiple Radar Targets, 10th International Conference on Communications, COMMUNICATIONS 2014, May 29-31, 2014, Bucharest, IEEE Xplore, 2014, pp.69-72, DOI 10.1109/ICComm.2014.6866690
- Adrian Macaveiu, Corina Nafornita, Alexandru Isar, Andrei Campeanu, Ioan Nafornita, A Method for Building the Range-Doppler Map for Multiple Automotive Radar Targets, International Symposium on Electronics and Telecommunications (ISETC), Timisoara, November 2014, 14-15 Nov 2014, 2014, pp.151-156
- Corina NAFORNITA, Adrian MACAVEIU, Alexandru ISAR, Ioan NAFORNITA, Andrei CAMPEANU, Envelope Detector with Denoising to Improve the Detection Probability, pp 59-64. May 29-31, 2014, Bucharest, 10th International Conf. on Communications, IEEE Xplore

Applicability and transferability of the results

The key result of the ARTRAC project is a safety system that aims to protect vulnerable road users, designed to be economically viable in the volume vehicle market. The safety system consists of both actuators for controlling vehicle driving dynamics and the perception component for the vehicle's surroundings. The ARTRAC detection system will be small, lightweight and economical in order to enable an easy integration in the vehicle design. More details: <http://vimeo.com/111830073>

Fields of interest

radar, sensor, vulnerable road users, protection, road condition detection, collision avoidance, assisted braking.



Research centre

Research Centre for Intelligent Signal Processing (ISPRC)



Financed through/by

The project is

- 75% funded by the EU 7th Framework Program (FP7 No. 284740/2011 – 120.183 €)
- 25% by the national Program PNII (contract 223EU/24.07.2013 – 178.996,74 lei)

Research team

Prof. Ioan NAFORNIȚĂ, PhD
Prof. Alexandru ISAR, PhD
Prof. Andrei CÂMPEANU, PhD
Assoc. Prof. Corina NAFORNIȚĂ PhD
Adrian MACAVEIU, PhD student



Contact information

Prof. Ioan NAFORNIȚĂ, PhD
Member of the Romanian Academy of Technical Sciences
Department of Communications
Address: Bd. Vasile Pârvan, No. 2, RO300223, Timisoara
Phone/Fax.: (+40) 256 403 302
Mobile: (+40) 722 567 912
E-mail: ioan.nafornita@upt.ro
Web: www.artrac.org

SY4SCI SYNERGY STUDY: OCEAN VIRTUAL LABORATORY

Goal of the project

The project will allow oceanography experts to discover the existence and then to handle jointly, in a convenient, flexible and intuitive way, the various co-located Earth Observed (EO) datasets and related model/in-situ datasets over dedicated regions of interest with a different multi facet point of view. The developed tools shall foster the emergence and prototype of new methods and products making use of the complementarity between sensors to study ocean related processes. The tool shall also provide the best possible visibility on the upcoming Sentinel1/2/3 data takes to help plan and coordinate with field campaign. The Ocean Virtual Laboratory (OVL) is filling the gap between Space agencies data portals that distributes specific EO data and analysis software dataset.

Short description of the project

The project aims to implement new software putting together two types of tools: a mathematical programming environment (as Matlab) and a geographical programming environment (as Google Earth). The raw data, as for example: Synthetic Aperture Radar (SAR) images, "temperature" images, "salinity" images, "altimetry" images; will be provided by satellites recently launched by the European Space Agency (ESA). The new software will have a multi-layer structure, each type of raw data representing a layer. The aim of new software is to exploit the information furnished by each layer and the difference of information obtained from different layers by hybridization (fusion), to characterize the phenomena at the ocean's surface (as the ocean currents for example). The tasks of the project are the following.

- Undertake an extensive scientific review to refine the project requirements and produce a consolidated Reference Baseline document.
- Implementation the SY-4Sci OVL novel synergy algorithms and the OVL platform, perform validation of new synergy products and access Sentinel1 and Sentinel3 products suitability for synergy studies.
- Write recommendation for further scientific research exploiting the synergy between ocean satellite sensors with a special focus on Sentinel1 and Sentinel3.
- Perform cross-cutting management and promotion of the SY-4Sci OVL project and open tools.

Implementation period

24 October 2014 – 24 October 2016.

Project implemented by

- OceanDataLab, Brest, France - Coordinator
- Institut Francais de Recherche pour l'Exploitation de la MER (IFREMER), Brest, France - Partner
- Nansen Environmental and Remote Sensing Center (NERSC), Bergen, Norway - Partner
- Politehnica University of Timisoara (UPT), Romania - Partner
- Institute of Oceanology of the Polish Academy of Sciences (IO PAN), Sopot, Poland and Plymouth Marine Laboratory (PML), Plymouth, UK - Partner

Main activities

- Review of existing synergy methods and consolidation of requirements,
- Define new methods and algorithm to be developed,
- Selection and preparation of EO products database,
- Specification and implementation of the prototype platform and processing modules,
- Specification and implementation of the prototype synergy processing modules,
- Validation of the developed tools and products,
- Recommendations for further scientific research.

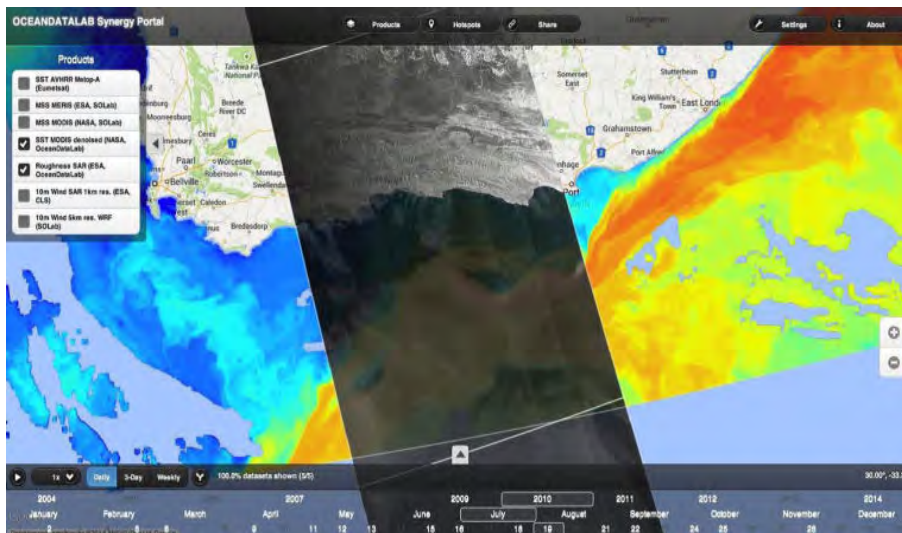

Results

- Deliverables
 - Requirements Baseline,
 - Algorithm Theoretical Basis document,
 - Product Specification document,
 - Product Validation Report,
 - Software User Manual.
- Dissemination
 - Publications,
 - Presentations

Applicability and transferability of the results

The subject is evaluated today at technology maturity level 1 (Scientific Research), and it is aimed to conclude the project at technology readiness level (TRL) 3 (Laboratory Experiments).

Financed through/by

- European Space Agency (ESA), ESRIN/Contract N° 4000112389/14/I-NB – consortium 250000 EURO,
- UPT: 24713 EURO.

Research centre

Research Centre for Intelligent Signal Processing (ISPRC)

Research team

Prof. Alexandru ISAR, PhD
Assoc. Prof. Corina NAFORNIȚĂ, PhD

Contact information

Prof. Alexandru ISAR, PhD
Department of Communications
Address: Bd. Vasile Pârvan, No. 1, RO300223, Timisoara
Phone/Fax.: (+40) 256 403 307
E-mail: alexandru.isar@upt.ro
Web: <http://www.tc.etc.upt.ro/isprc/>

IMAGE FUSING TECHNIQUES (IMFUSING)

Goal of the project

The Line of Sight (LoS) of a satellite could be disrupted by obstacles, reducing the accuracy of the information provided to a Global Navigation Satellite System (GNSS) receiver. The first objective of the project is to eliminate or weight the signals coming from these satellites. To do simpler the identification of satellites having a direct LoS with the GNSS receiver this project proposes, as a supplementary sensor, to use a fish eye camera. The segmentation of the image provided by the fish eye camera permits to identify the satellites that are not on the LoS of the GNSS receiver.

Short description of the project

To provide sufficient information to the GNSS receiver, at the image processing level, the algorithms conceived will include the calibration of the camera sensor, image segmentation techniques, and distance and angle measurements deduced from calibrated image analysis. The algorithms at user sensor level will use camera information to discard measurements, will estimate boundaries of accuracy, will build a Quality of Service (QoS) indicator on the computed position and will authenticate the position. The algorithms at tracking loop level will use camera information to adjust the GNSS receiver correlator.



Project implemented by

Politehnica University of Timisoara - Coordinator
Thales-Alenia Toulouse France - Partner

Implementation period

1 October 2014 – 30 March 2017

Research centre

Research Center for Intelligent Signal Processing

Main activities

Phase I 01/10/2014–31/03/2015: State of the art analysis,

Phase II April 1 2015 – March 31 2017

01/04/2015–30/09/2015: Core technical development

01/04/2015–31/01/2016: Test campaign

01/12/2015–31/05/2016: Performance analysis

01/06/2016–30/09/2016: Dissemination and exploitation.

Results

Deliverables:

Report on the State of the art in Image-GNSS fusion,
Preliminary Design Review Report,
Test Review Board Report
MATLAB codes for developed algorithms.

Dissemination:

Scientific paper in a scientific journal,
Technical Note on synthesis of the study.

Applicability and transferability of the results:

The subject is evaluated today at technology maturity level 1 (Scientific Research), and it is aimed to conclude the project at technology readiness level (TRL) 3 (Laboratory Experiments).

Financed through/by

European Space Agency (ESA), contract number 10031/02.08.2013
UPT: 128.234 EURO, Thales Alenia: 70.000 EURO

Research Team

Prof. Miranda NAFORNIȚĂ PhD, Assoc. Prof. Corina NAFORNIȚĂ PhD,
Prof. Andrei CĂMPEANU PhD, Prof. Ioan NAFORNIȚĂ PhD, Prof. Marius
OTEȘTEANU PhD, Prof. Vasile GUI PhD, Prof. Alexandru ISAR PhD,
Assist. Prof Ciprian DAVID PhD.

Contact information

Prof. Alexandru ISAR, PhD
Department of Communications
Address: Bd. Vasile Părvan, No. 1, RO300223, Timisoara
Phone/Fax.: (+40) 256 403 307
E-mail: alexandru.isar@upt.ro
Web: <http://www.tc.etc.upt.ro/isprc/>

IONOSPHERIC PROPAGATION PREDICTIONS AND WIDEBAND COMMUNICATIONS USING HF SDR SENSORS FOR INFORMATIONAL SUPPORT IN EMERGENCY SITUATIONS IN ROMANIA

Goal of the project

The project aims to implement software and hardware solutions that integrate ionospheric sounding algorithms in a network of SDR (Software Defined Radio) sensors in order to develop and validate a HF (High Frequency) ionospheric prediction model for the territory of Romania.

Short description of the project

The project targets a systemic approach of the communication network through the implementation, development and integration of recent technological solutions from the perspective of providing information support for the management of interventions in disaster areas where communication infrastructure does not exist or is damaged. Project results can be applied not only in the rapid resolution of remote communications in emergency situations, but also can be extended to other applications in the HF communications range, such as encrypted data communication links for the government or the military.

Project implemented by:

- Land Forces Academy "Nicolae Bălcescu", Sibiu - Coordinator
- Interactive Systems & Business Consulting, Bucharest - Partner
- Politehnica University of Timișoara - Partner
- Technical University of Cluj-Napoca - Partner

Implementation period

21.11.2014 - 30.06.2016

Main activities

- Building a SDR sensor network for ionospheric sounding
- Elaboration of an application for HF propagation predictions in Romania.
- Development of broadband HF communications by the implementation of adaptive systems

Results

The main deliverables of the project are

- an ionospheric model which is specific for Eastern Europe;
- algorithms for the automatic identification and classification of waveforms in order to increase the transfer rate and to implement techniques for dynamically accessing the HF resources;
- SDR solutions for local monitoring and collaborative spectrum sensing in the HF range;
- a HF radio network on the territory of Romania which allows high transfer rates in collaborative environments, by automatically adapting to specific conditions of ionospheric propagation at high angles of elevation.

Financed through/by

PN-II-PT-PCCA-2013-4

Research team

Prof. Aldo De SABATA, PhD
Assoc. prof. Septimiu MISCHIE, PhD
Assist. lect. Cornel BALINT, PhD
Assist. lect. Ciprian DUGHIR, PhD
Assist. lect. Cora IFTODE, PhD

Contact information

Prof. Aldo DE SABATA, PhD
Department of Measurement and Optical Electronics
Address: Bv. Vasile Pârvan, No. 2, RO300223, Timisoara
Phone: (+40) 256 403 370
E-mail: aldo.de-sabata@upt.ro

INTER-UNIVERSITY PARTNERSHIP FOR EXCELLENCE IN ENGINEERING - PARTING

Goal of the project

- Improvement and stimulation of participation to doctoral programs.
- Attracting potential researches to pursue a career in research for stimulating economic growth and development of knowledge-based society.
- Improvement of mobility during doctoral studies.
- Promoting interdisciplinarity in engineering
- Enhancing adaptability in a continuously changing scientific and economic environment

Short description of the project

- 25 scholarship grants awarded to 25 doctoral students for 18 months
- Domains: Information Technology; Electronics and Telecommunications; Systems Engineering; Power Systems and Energy; Environmental Sciences; Architecture; Materials Science; Mechanical and Industrial Engineering; Management.

Project implemented by

- Technical University of Cluj-Napoca - coordinator
- Politehnica University of Timisoara - partner
- Transilvania University of Brasov - partner

Implementation period

01.01.2014 - 31.06.2015

Main activities

- Scholarship grants for 25 doctoral students
- Financial assistance for long term mobility (more than one month) in EU universities
- Financial assistance for publications and participation to scientific conferences

Results

- Increase of number of PHD theses sustained
- Increase of number of published papers
- Improvement of quality of doctoral programs through interdisciplinarity
- Trans-national and inter-regional development

Financed through/by

Operational Sectorial program for Development of Human Resources - POSDRU 2007-2013

Priority Axis: 1. Education and Professional Formation for Supporting Economic Growth and Development of Knowledge-Based Society

Intervention Domain: 1.5 Doctoral and Post-Doctoral Programs for Supporting Research

Research team

Prof. Aldo De SABATA, PhD
Ec. Cristina BUNEA

Contact information

Prof. Aldo De SABATA, PhD
Department of Measurement and Optical Electronics
Address: Bd. Vasile Pârvan, No. 1, RO300223, Timisoara
Phone/Fax.: (+40) 256 403 370
E-mail: aldo.de-sabata@upt.ro

EXPERIMENTAL MODEL FOR AN AUTOMATIC CAPACITIVE COMPENSATOR DESIGNED FOR IMPROVING THE POWER FACTOR AND FOR LOAD BALANCING IN LOW-VOLTAGE ELECTRICITY DISTRIBUTION NETWORKS - CAEREDJT

Goal of the project

The project is intended to finance industrial research activities, needed to put in practice under the form of an experimental model of research findings of a group of academics from UPT, concerning the network load balancing electric phase through cross unbalanced capacitive compensation. In electrical networks, capacitive load variation implies variation of the capacity compensation, thus the need for building an unbalanced capacitive automatic compensator, to record load variation.

Short description of the project

The automatically unbalanced capacitive compensator proposed by this project is an innovative product, so achieving a functional experimental model involves overcoming a number of scientific and technical challenges, the most important being: control and single-phase switching of the capacitor batteries steps, the construction algorithm and implementation of a programming language for PLC process control, process optimization for automatic compensation.

Project implemented by

- Politehnica University of Timisoara – Lead partner
- S.C. ICPE S.A. Bucharest – Project partner

Implementation period

01.07.2014 - 30.06.2016

Main activities

1. Conducting studies and analysis on the alternative constructive solutions and developing the technical documentation for the construction of the experimental model.
2. Manufacturing of the experimental model and the analysis, control and monitoring systems.
3. Testing the model and proving its functionality and its utility
4. Dissemination of results and protect the intellectual property rights.

Financed through/by

UEFISCDI

Applicability and transferability of the results

The results of the project are useful for unbalanced electrical loads supplied at low voltage level, and also for the Distribution system operator (DSO).

Results

- The main outcome of the project will be a functional experimental model and its documentation of implementation for a capacitive compensator designed to improve power factor and load balancing in networks of low voltage power distribution.
- It will underpin the design and construction in a later stage, of a prototype of a capacitive automatically balance high power compensator (tens of kVA) for increasing network performance of low-voltage power distribution and utilization facilities connected to it, by reducing reactive power flow and load balancing.
- The results of the research will be disseminated in scientific papers in professional journals or communication conferences.
- New technical solutions brought by this automatic capacitive compensator, as regard to the structure, order, sizing, automatic control algorithm, will be the subject of intellectual property protection activities.

Research team

Assoc.Prof. Adrian PANĂ, PhD
Prof. Radu - Emil PRECUP, PhD
Prof. Ștefan PREITL, PhD
As. Florin MOLNAR-MATEI, PhD
As. Alexandru BĂLOI, PhD
Lecturer Ilie Mihai TĂUCEAN, PhD
Lecturer Mircea-Bogdan RĂDAC, PhD
As.Claudia-Adina BOJAN-DRAGOȘ, PhD
Alexandra Iulia STÎNEAN, PhD
Eng. Andrei PLETTLINGER

Contact information

Assoc. Prof. Adrian PANĂ, PhD
Department of Power Engineering
Address: Bv. Vasile Pârvan, No. 2, RO300223, Timisoara
Phone: (+40) 256 403420
E-mail: adrian.pana@upt.ro
Web: <https://sites.google.com/site/caeredjt/>

NEW FABRICATION CONCEPT OF SILVER NANOWIRE/POLYANILINE TRANSPARENT, CONDUCTIVE AND FLEXIBLE ELECTRODES FOR SOLAR CELLS

Goal of the project

The aim of the project is to develop transparent, conductive and flexible electrodes for solar cells based on silver nanowire/polyaniline hybrid materials and to offer a new technical solution to decrease the sheet resistance of the silver nanowires embedded in the polymer matrix. Low melting point metallic nanoparticles (In and Sn) will be deposited on the surface of silver nanowires, allowing to weld the nanowires and to obtain a network with high electrical conduction paths.

Short description of the project

A great challenge in the actual research of solar-to-electricity conversion is the construction of flexible solar cells. Although indium tin oxide (ITO) deposited on plastic is traditionally used for organic solar cells and light emitting diodes, solutions are searched to replace the ITO layer and to manufacture cheap transparent conducting electrodes. Silver nanowires (AgNWs) are a promising candidate to replace ITO due to their high electric conductivity and corrosion resistance, but there is still the issue of increased resistance on wire contacts. The proposed solution involves the modification of the AgNWs by deposition on their surface of metallic nanoparticles with low melting temperatures like tin and indium. The modified nanowires will be suspended in a proper medium to form an electroconductive ink that will be deposited on flexible polymeric sheets. The nanowires will be welded by thermal treatment, with and without the application of static pressure

Project implemented by

Politehnica University Timisoara
Department of Applied Chemistry and Inorganic Compounds and Environmental Engineering

Implementation period

02.09.2013–30.09.2016

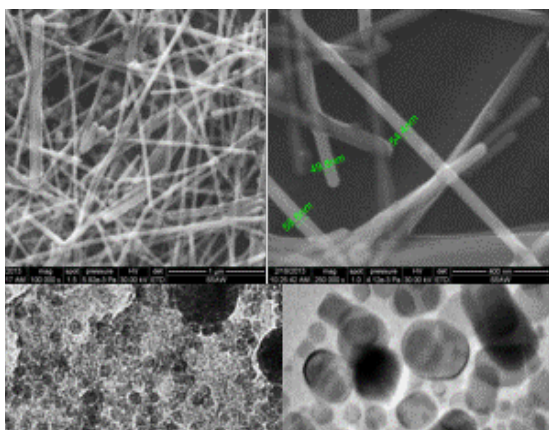

Main activities

Research activities:

- Synthesis and characterization of silver nanowires with controlled aspect ratio (2013).
- Synthesis and characterization of indium and tin nanoparticles (2014).
- Development and characterization of transparent conductive electrodes on flexible substrates using silver nanowires and assessment of their electrical and optical properties (2014)
- Synthesis and characterization of silver nanowires modified with tin and indium nanoparticles and preparation of electroconductive inks based on modified Ag nanowires (2015)
- Manufacturing of modified Ag nanowires-based flexible, transparent and conducting electrodes, with high diffuse transmittance and low sheet resistivity by coating the electro-inks on flexible substrates (2015)
- Deposition of a conducting polymer on previously manufactured electrodes and their use in the construction of dye-sensitized solar cells (2016).

Results

- Samples of silver nanowires
- Samples of indium and tin nanoparticles
- Samples of transparent and conductive electrodes

ISI publications:

- R. Banica, D. Ursu, C. Sarvas, S. F. Rus, S. Novaconi, A. Kellenberger, A.V. Racu, T. Nyari, Electrical properties optimization of silver

International conferences

- R. Banica, R. Baies, R. Bucur, C. Locovei, A. Kellenberger, T. Nyari, Study of liquid phase synthesis of silver nanowires for solar cell applications, 3rd European Energy Conference – E2C 2013, October 27–30, 2013 – Budapest, Hungary.
- R. Banica, R. Baies, D. Ursu, M. Poienar, T. Nyari, Silver nanowires synthesis in the PVP-silver-chloride system, ECO IMPULS 2013, November 7–8, Timisoara, Romania.

- R. Banica, C. Sarvas, S.F. Rus, S. Novaconi, A. Kellenberger, T. Nyari, Optimization of the electrical and mechanical properties of transparent electrodes based on silver nanowires supported on polyethylene terephthalate, International Symposium on Flexible Organic Electronics ISFOE 14, 7-10 July, 2014 – Thessaloniki, Greece.
- R. Banica, C. Sarvas, S.F. Rus, D. Ursu, S. Novaconi, A. Kellenberger, T. Nyari, Manufacture of ultrathin transparent electrodes based on silver nanowires with application to three-dimensional solar cells, International Symposium on Flexible Organic Electronics ISFOE 14, 7-10 July, 2014 – Thessaloniki, Greece.
- L. Cseh, C. Locovei, O. Marinica, A. Kellenberger, T. Nyari, R. Banica, Synthesis and characterization of indium nanoparticles as precursor for solar cells, New trends and strategies in the chemistry of advanced materials with relevance in biological systems, technique and environmental protection. New trends and strategies in the chemistry of advanced materials, 5-6 June, 2014 – Timisoara, Romania

Applicability and transferability of the results

The manufacture of electroconductive inks based on silver nanowires covered with metal nanoparticles with low melting points is expected to have wide technological applications and an important economic impact. This type of conductive inks may be used not only for flexible solar cells but also for other optoelectronic devices, such as flexible LEDs, organic thin film transistors, organic lasers and photo detectors, electronic paper, disposable sensors, low-cost smart cards and RF identification tags, or flexible arrays of plastic microphones.

Financed through/by

UEFISCDI - Executive Agency for Higher Education, Research, Development and Innovation Funding, Programme IDEAS, Exploratory Research Projects.

Research centre

Research Centre for Environmental Science and Engineering

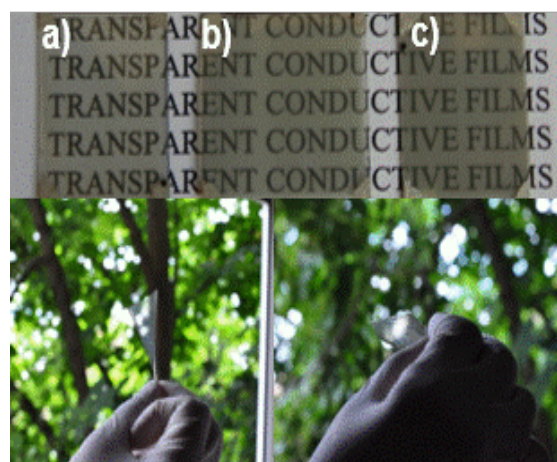

Research team

Assoc. Prof. Andrea KELLENBERGER, PhD – project manager
Prof. Nicolae VASZILCSIN, PhD – senior researcher
Terezia NYARI – senior researcher
Liliana CSEH – senior researcher
Radu Nicolae BANICA – postdoctoral researcher
Cosmin LOCOVEI – postdoctoral researcher
Radu BAIES – postdoctoral researcher
Mircea Laurentiu DAN – PhD student
Alin BUCUR – PhD student
Daniel Horatiu URSU – PhD student
Paul Cristian CAPOTA – master student

Contact information

Assoc. Prof. Andrea KELLENBERGER, PhD
Department of Applied Chemistry and Inorganic Compounds and Environmental Engineering
Address: Carol Telbisz Street, No. 6, RO300001, Timisoara
Phone: (+40) 256 404 178
Fax (+40) 256 403 060
E-mail: andrea.kellenberger@upt.ro
Web: http://www.chim.upt.ro/Facultatea-de-Chimie-Industrialasi-Ingineria-Mediului_PN-II-ID-PCE-2012-4-0398_qMI.html

BIOCATALYST-CLICK CHEMISTRY DOWNSTREAMING TANDEM BASED INNOVATIVE KIT FOR OPTICALLY PURE FINE CHEMICALS SYNTHESIS

Goal of the project:

The project goal is to develop an innovative kit for efficient and cost-effective sequential continuous flow large-scale (multigram) preparation of optically pure chiral building blocks useful for synthesis of pharmaceutical compounds and agricultural chemicals, based on tailor-made immobilized lipases mediated kinetic resolution of various racemic substrates and a subsequent click chemistry like efficient down streaming of the reaction mixture.

Short description of the project

In this project a chemo-enzymatic process which integrates several innovative steps in both biocatalytic and down streaming parts will be set up. The utilization of tailor-made biocatalysts in industrial processes is an innovative approach, technically comparable to the synthetic solutions but with higher economic benefits. The use of immobilized biocatalysts-click chemistry tandem will permit to design easily scaled-up continuous flow procedures for industrial manufacturing of the target compounds, underlining the economic relevance of the proposal.

Project implemented by

- Politehnica University of Timișoara – Project leader
- University “Babes-Bolyai” Cluj Napoca – Partner 1
- Natural INGREDIENTS R&D S.R.L – Partner 2

Implementation period

01.07.2014-30.06.2016

Main activities

1. Preparation of various precursors: (hetero)aryl-ethanols, hydroxy- and amino acids and synthesis of various propargylic esters as O- and N-acylating agents used in enzymatic kinetic resolution (EKR).
2. Development of optimal EKR and click-chemistry type down streaming procedures.
3. Immobilization of lipases.
4. Development of the continuous flow procedure

Applicability and transferability of the results

The obtained kit, as well as the high-value products, will be marketable, but the process will be appropriate for further scaling-up, depending on the customer demands.

Financed through/by

UEFISCDI

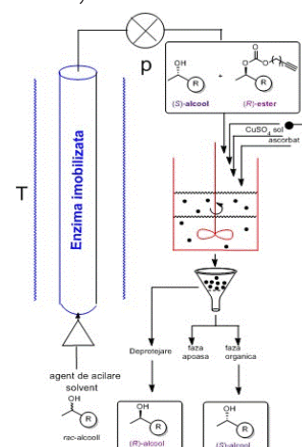

Results

1. Multi-gram amounts of various racemic compounds and various propargylic esters as acyl donors for the EKR;
2. Enantiomeric separation protocol for previously synthesized racemates, chromatographic protocols for testing the enantioselectivity of the enzymatic reactions;
3. Scientific article submitted to an ISI quoted journal;
4. Scientific presentation, published in the abstract book of an international conference;
5. Experimental protocol of down streaming procedures;
6. Immobilization protocols and analysis procedures for tailor-made immobilized lipases;
7. Integrated EKR-click-chemistry type down streaming procedure;

Research team

Prof. Francisc PETER, PhD	Eng. Anamaria TODEA
Assist. Prof. Cristina PAUL, PhD	Eng. Adinela CIMPORESU
Valentin BADEA, PhD;	Eng. Claudiu MARCU
Emese BIRO, PhD;	Eng. Ioana BRĂZDĂU

Contact information

Prof. Francisc PETER, PhD
 Department of Organic and Natural Compounds Engineering
 Address: Carol Telbisz Street, No. 6, RO300001, Timisoara
 Phone: (+40) 256 404216
 Mobile: (+40) 745637530
 E-mail: francisc.peter@upt.ro
 Web: http://chim.upt.ro/Facultatea-de-Chimie-Industrial-a-si-Ingineria-Mediului_PN-II-PT-PCCA-2013-4-0734_qqpYW.html

TEMPERATURE ASSESSMENT OF A VERTICAL STEEL MEMBER SUBJECTED TO LOCALISED FIRE PROJECT (LocaFi)

Goal of the project

The main goal of the project is to improve the existing knowledge on the effects of the localized fires in a building compartment. With the actual methodology included in the Eurocodes for the fire design of buildings, it is only possible to assess the temperature of a steel element in the vertical axis of the localised fire. It is impossible to assess the temperature or the flux received by a vertical member at a given distance of the fire source.

Short description of the project

The project is devoted to the development of an analytical model for the calculation of the temperatures in the vertical structural steel elements of a building, subjected to localised fires.

The new method, developed by means of experimental and numerical research, will provide the fluxes received in any point of a building compartment subjected to a localised fire.

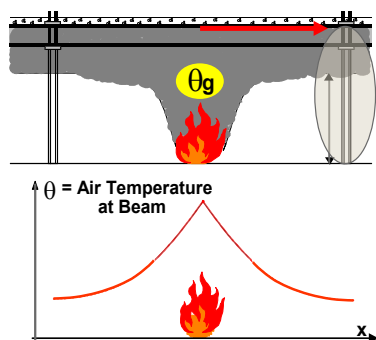

Project implemented by

- ArcelorMittal Luxembourg (coordinator)
- Centre Technique et Industriel de la Construction Métallique, France
- Politehnica University of Timisoara, Romania
- Universite de Liege, Belgium
- University of Ulster, Ireland

Implementation period

01.07.2012- 30.06.2015

Fields of interest

Design of buildings in fire situation.

Financed through/by

Research Fund for Coal and Steel - RFCS

Research centre

Research Center for Mechanics of Materials and Structural Safety - CEMSIG

Main activities

- Collection of the different national annexes and national parameters for the application of the Natural Fire Models in different European countries and implementation of these parameters in a Software;
 - Definition and realisation of laboratory tests assessing the effect of the real flame emissivity for element engulfed into the fire;
 - Definition and realisation of laboratory tests assessing the fluxes received by an element subjected to localised fire but not engulfed in the fire;
 - Development and validation using CFD models of simplified analytical model for the evaluation of the fluxes received by an element in any point of a compartment;
- Implementation of the developed analytical model in a user-friendly tool;
- Redaction of a design guide for the application of the new methodology including design examples.

Results

Design procedures based on the analytical models developed within the project will be proposed.

Applicability and transferability of the results

The analytical models developed within the project will be introduced in a user friendly software and in an advanced calculation model for fire design, in order to offer a large utilization of the procedure for the construction market.

Research team

Assoc. Prof. Raul ZAHARIA, PhD
 Prof. Dan DUBINĂ, PhD
 Lecturer Dan PINTEA

Contact information

Assoc. Prof. Raul ZAHARIA, PhD
 Department of Steel Structures and Structural Mechanics
 Address: Str. Ioan Curea, No. 1, RO300224. Timisoara
 Phone: (+40) 256 403 922
 E-mail: raul.zaharia@upt.ro

EUROPEAN PRE-QUALIFIED STEEL JOINTS (EQUALJOINTS)

Goal of the project:

The goal of the project is to introduce in the European practice a qualification procedure for the design of moment resisting connection in seismic resistant steel frames, in compliance with EC8 requirements.

Particular objectives of the project are to qualify a set of standard all-steel beam-to-column joints, develop pre-qualification charts and design tools that can be easily used by designers. The project is also intended as a pre-normative research aimed at proposing relevant design criteria to be included in the next version of EC8. Besides it would contribute to the advancement of knowledge in the field of seismic behavior of steel moment resisting joints usually adopted in moment resisting frames (MR), in un-braced bays of dual moment-resisting/concentrically braced frames (MR+CB) and in moment-resisting/eccentrically-braced frames (MR+EB).

Short description of the project:

The project is the first attempt in Europe to produce qualification tools for seismic-resistant joints. Novel design methodologies and details for beam-to-column connections that are reliable, feasible and economical, solving also the open issue of design by testing required by EC8 for partial strength/stiffness connections will be provided. The cyclic behavior of beam-to-column joints has a crucial role on the overall seismic response of both MR and dual frames. Recent studies highlighted the influence of joint rotation capacity on the seismic response of mid-rise MR frames designed according to EC8.

The innovative content of the project is represented by:

- Experimental investigations on 96 beam-to-column joint specimens covering: three typical European typologies and one US dog-bone joint typology made of heavy cross sections;
- Evaluation of the influence of different parameters (e.g. axial force, loading protocol and member sizes) on the joint performance;
- Development of codified pre-qualification charts of typical beam-to-column joints used in EU practice.
- In Europe these tools do not exist in design codes. Hence, this project was intended as pre-normative research aiming to propose design guidelines for the future version of EC8.

Project implemented by

- University of Naples "Federico II", Department of Structures for Engineering and Architecture.
- Poitehnica University of Timisoara, Department of Steel Structures and Structural Mechanics

Implementation period:

01.07.2013 – 31.06.2016

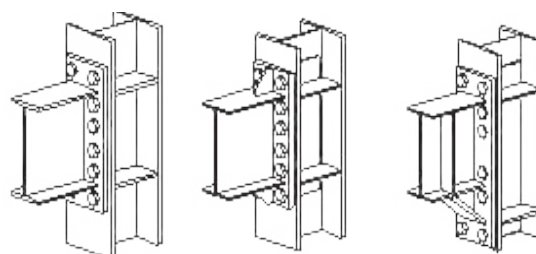

Main activities:

With respect to the aim and objectives of the project, a set of multi-storey building frames were analysed at CEMSIG centre for the selection of member cross sections for joint assemblies. The design procedure for joints was established according to the provisions of EC3, EC8 and AISC 358. Extensive pre-test finite element (FE) numerical simulations were carried out aimed to offer an accurate prediction of the joint behaviour and to find answers to problems for which decisions were taken in the design process. In addition, the experimental test set-up was designed, and validated through FE numerical simulations. As a result, shop drawings for specimens and test set-up were performed.

Future activities will be devoted to the experimental investigation of material samples, and 24 large-scale joint assemblies. In addition, the numerical models of the joints will be calibrated based on monotonic and cyclic test results, which will allow extending the experimental program with a parametrical study. Finally, the design procedure will be validated based on experimental and numerical results.

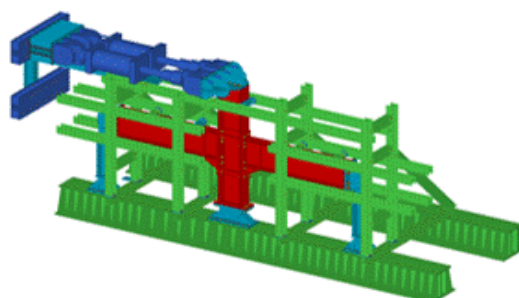

Results:

Particular results are represented by the selection of members (beams & columns) from the analyzed frames, and the development of a design procedure for bolted beam-to-column haunched connections. The pre-test numerical simulations lead to some adjustments of the joint design procedure and joint configurations. As a result, the joint configurations were established and the experimental test set-up was designed. Finally, the shop drawings for joint specimen and test set-up were completed.

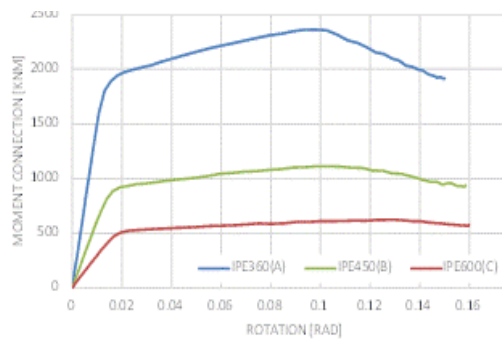
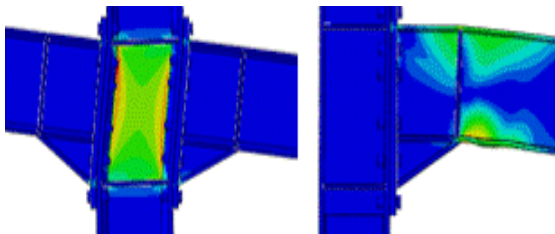

Applicability and transferability of the results:

- The project provides easy-to-use design tools for engineers and promotes saving cost solutions. In addition, the outcomes of the project will be largely beneficial for the EU industry. Because the US joints examined within EQUALJOINTS will be made of heavy sections, which are produced only in Europe, this will be an important opportunity to get on the US Market, consolidating the gain of EU economy and having beneficial impact to exportation of EU products.
- The impact and transferability of the project is by no means restricted to the selected joint configurations and this project will open the door for other joints to be included in future updates of the guidelines.

Financed through/by

Research Fund for Coal and Steel, grant agreement RFSR-CT-2013 – 00021.

Fields of interest:

Seismic resistant structures for multi-storey building frames.

Research Center

The Research Centre for Mechanics of Materials and Structural Safety – CEMSIG, Politehnica University of Timisoara.

Research team

- University of Naples “Federico II” (UNINA) – Coordinator
- Imperial College (IC)
- University of Coimbra (UC)
- University of Liege (ULg)
- Politehnica University of Timisoara (UPT)
- European Convention for Constructional Steelwork (ECCS)
- ArcelorMittal Belval & Differdange S.A. (AM)
- CORDIOLI & C

Contact information

Prof. Dr. H. C. Dan DUBINĂ, PhD
Corresponding Member of Romanian Academy
Department of Steel Structures and Structural Mechanics
Address: Str. Ioan Cărea, No. 1, RO300224, Timisoara
Phone: (+40) 256 403 920
Fax: (+40) 256 403 917
E-mail: dan.dubina@upt.ro

SEISMIC PROTECTION OF ENGINEERING STRUCTURES THROUGH DISSIPATIVE BRACES OF NANO-MICRO MAGNETO-RHEOLOGICAL FLUID DAMPERS – SEMNAL-MRD

Goal of the project:

The goal of the project is to develop a seismic protection system, which uses magneto-rheological fluid (MRF) dampers, acting as semi-active structural control system. Particular objectives are:

- To develop nano-micro MRF compatible with application in seismic MR dampers;
- To design and built a 10tf capacity MR damper;
- To provide type tests, based on EN 15129-2009: Anti-seismic devices, aimed to validate, calibrate and model the damper;
- To design, execute and test a brace-damper assembly in order to validate the integration of damper and brace, including connections;
- To propose structural application schemes for implementation in practice of semi-active control brace-MRD systems.

Short description of the project:

There are three strategies for the seismic protection of structures: (i) reduce seismic demands, (ii) enhance structural damping, and (iii) use active or semi-active structural control. The current project involves the third approach focusing on semi-active systems. Semi-active devices have properties that can be adjusted in real time but cannot inject energy into the controlled system. Many of them can operate on battery power alone, proving advantageous during seismic events when the main power source to the structure may fail. The most promising devices suitable for implementation into a semi-active control appear to be magneto-rheological (MR) dampers, which succeed in overcoming many of the expenses and technical difficulties associated with other types of semi-active devices.

Response characteristics of MR devices can be changed by varying the magnetic field through different current inputs. In addition to its small power requirement, the MR damper can transfer large forces at low velocities. Currently there are MR dampers with capacities up to 200 kN and research results proved the possibility to obtain capacities up to 400-500 kN.

Project implemented by

- The Research Centre for Mechanics of Materials and Structural Safety – CEMSIG, Politehnica University of Timișoara.



Implementation period:

01.07.2014 – 30.06.2016

Main activities:

The activities of the project are divided in three stages (I/2014, II/2015, III/2016), of which the first was completed. The particular activities covered the establishment of the seismic action for two locations (Timișoara, București), and the estimation of the functional parameters corresponding to the MR damper.

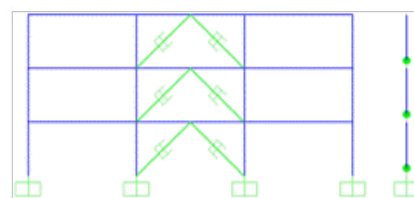
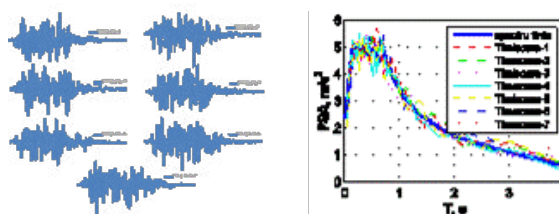

Response of the damper (3rd floor)

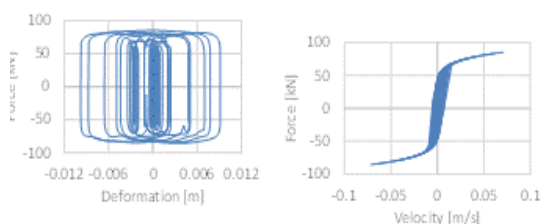

Response of the frames

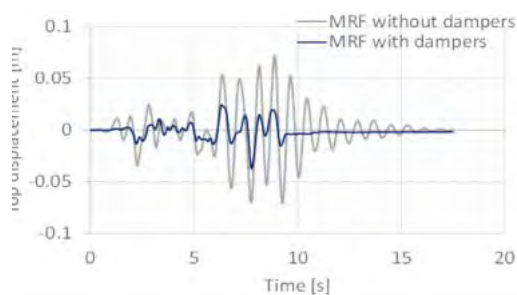

Further, a MR damper of 10 tons capacity will be designed, fabricated and tested under different loading conditions (triangular, sinusoidal, random excitations). In addition, numerical hysteretic models will be calibrated based on the tested MR damper enabling the modeling of structural response. Since the dampers in structural systems will be coupled with braces, both single damper and brace-damper assembly tests will be performed. With a numerically simulated control unit, structural systems equipped with brace-damper assemblies will be numerically tested in order to observe and characterize their behavior.

Results:

The results of the first stage comprise two sets of artificial accelerograms (stiff and soft soil) and the estimated functional parameters of the MR damper (i.e. force, deformation, velocity). It can be highlighted that the calibration procedure of the functional parameters was established, and the dependence of the parameters was identified in relation to the nature of the seismic motion. Besides, the main outcomes of the project will be:

- Nano-micro composite MR fluid recipes for seismic semi-active dampers;
- The technical solution for the MR damper;
- The prototype of the MR damper;
- Validation tests of brace-damper systems;
- Numerical evaluation of effectiveness of MR dampers in reducing seismic effects in structural applications.
- Design and numerical testing of the control algorithm on single degree of freedom systems.

Applicability and transferability of the results:

- Considering the seismicity of Romanian territory and the effectiveness of the dissipative devices targeted in the project (once under fabrication, the implementation in new and existing structures would be quite easy), the national market potential is very large. On the other hand, this market can comprise all the Balkan's area, including Turkey and Greece, with development potential towards neighbouring Asian Countries.

Financed through/by

The project is supported by a grant of the Romanian National Authority for Scientific Research, CNDI-UEFISCDI, project Nr. 77/2014 (PN-II-PT-PCCA-2013-4-1656).

Fields of interest:

Seismic resistant structures for multi-storey building frames

Research Center

The Research Centre for Mechanics of Materials and Structural Safety – CEMSIG, Politehnica University of Timisoara.

Research team

- UPT - Politehnica University of Timișoara
- S.C. ROSEAL S.A.
- IMS-AR, Institute of Solid Mechanics of the Romanian Academy
- AR-FT, Timișoara Branch of the Romanian Academy
- S.C. TITAN S.A.

There are no secrets to success. It is the result of preparation, hard work, and learning from failure.

Colin Powell

Contact information

Prof. Dr. H. C. Dan DUBINĂ, PhD
Corresponding Member of Romanian Academy
Department of Steel Structures and Structural Mechanics
Address: Str. Ioan Curea, No. 1, RO300224, Timisoara
Phone: (+40) 256 403 920
Fax: (+40) 256 403 917
E-mail: dan.dubina@upt.ro

IMPLEMENTATION INTO ROMANIAN SEISMIC RESISTANT DESIGN PRACTICE OF BUCKLING RESTRAINED BRACES (IMSER)

Goal of the project:

Goal of the project: The goal of the project is to create the background for quick implementation of the steel frames with buckling-restrained braces (BRB) into Romanian practice design.

Short description of the project:

The latest version of the Romanian seismic design provisions (P100-1/2013) have introduced, for the first time in Europe, design provisions for buckling restrained braced frames (BRBF). Buckling restrained braces have a great potential in the field of seismic design of structures due to their large ductility and symmetrical cyclic response, as compared with conventional braces.

BRBF can be used both for new construction, as well as for strengthening of existing reinforced concrete, steel or masonry structures. BRB frames are able to provide two key properties of a seismic resistant structure: stiffness (for reducing interstorey drifts under moderate earthquakes) and ductility (for energy dissipation capacity under large earthquakes). BRBs were studied extensively worldwide over the past 30 years and have many practical applications especially in Japan and United States. Though researched in Europe as well, BRBs were applied in a very few applications here. The main reasons for lack of application into practice are believed to be the absence of design provisions in EN 1998-1, not enough acquaintance with the system by practicing structural engineers, need for experimental validation, and proprietary character of most BRB devices.

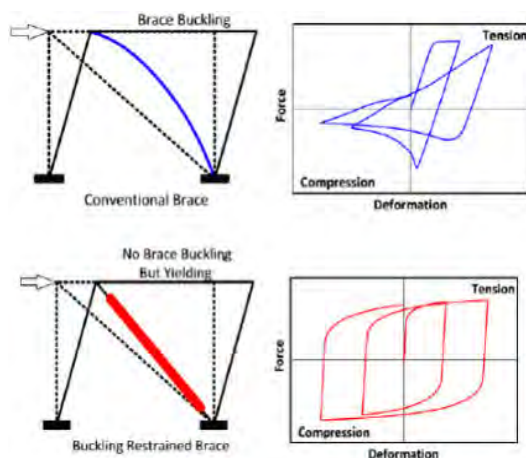

Project implemented by

- Project implemented by: CEMSIG – The Research Center for Mechanics of Materials and Structural Safety, Research and Technical Development unit of Politehnica University Timisoara, at the Faculty of Civil Engineering, Department of Steel Structures and Structural Mechanics.

Implementation period:

01.07.2014 – 30.06.2016

Main activities:

- Development of two different types of BRB prototypes: “conventional” (steel core / mortar / steel casing) and “dry” (without mortar), followed by a prequalification testing program on a set of BRBs of different capacity. This will provide an initial database on prequalified BRBs, rendering project-specific experimental programs unnecessary, at least for most common design situations;
- Transfer of the “know-how” on design and production of two types of BRBs to the industrial partner, who will be able to set up quantity production of these devices;
- Development of design guidelines for buckling restrained braces (at the device level). It will allow production of generic BRBs by local producers at more competitive prices than imported ones. “Dry” (or “steel-only”) BRBs are believed to be especially suited for this purpose, as they can be easily adopted by steel fabricators;
- Development of design guidelines and design examples for steel BRB frames (at system level).
- Dissemination of the project outcomes to practising engineers, through presentations in annual conferences of the Association of Structural Engineers (AICPS) and through two workshops organised in Bucharest and Timisoara.

Results:

The following results were achieved up to the present date:

- Design of prototype BRBF and MRF structures for two building typologies (low-rise and mid-rise), which are located in two different seismic zones (Bucharest, $T_C = 1.6$ s and Timisoara, $T_C = 0.7$ s). Four BRBFs were designed according to Eurocode 3, Eurocode 4 and P100-1 /2013. Two of them were 3 storey-high ($H = 10.50$ m) and the plan layout was 3 spans of 7.5 m by 5 bays of 7.5 m. The other two were 6 storey-high ($H = 21.00$ m) and had the same plan layout. BRBs were disposed in chevron configuration. Moreover, a 3 storey-high MRF was designed ($H = 10.50$ m, plan layout with 3 spans of 7.5 m by 5 bays of 7.5 m, located in Bucharest). It will be used for comparative assessment of analysed structures from the economic and technical point of views.

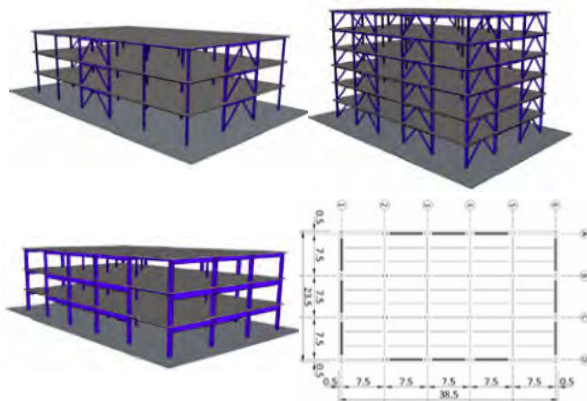

- Selection of typical capacities of BRBs. Two typical BRB capacities were selected (300 kN, respectively 700 kN), which together can cover a range of demands in BRBs ranging from 136 kN to 839 kN.
- Synthesis of existing information on performance and design of BRBs. A comprehensive literature review was performed identifying options for component materials, technology and design methods. These will serve as a starting point for developing a set of “dry” and “conventional” BRBs to be prequalified through an extensive numerical and experimental program.

Applicability and transferability of the results:

- A Design Guide for both “dry” and “conventional” BRBs for manufacturers, as well as a Design Guide (including examples) for steel BRB frames for practising engineers will be produced within the project. Moreover, a set of BRBs will be prequalified, eliminating the need of project-specific testing. The design guidelines and the prequalification will facilitate the use of BRBs in the Romanian design practice.

Financed through/by

The project is supported by a grant of the Romanian National Authority for Scientific Research, CNDI–UEFISCDI, project Nr. 99/2014 (PN-II-PT-PCCA-2013-4-2091).

Research Center

The Research Centre for Mechanics of Materials and Structural Safety – CEMSIG, Politehnica University of Timisoara.

Research team

- Politehnica University of Timisoara, (coordinator);
- SC Popp & Asociații SRL, Bucharest;
- SC HYDOMATIC SISTEM SRL, Timisoara.

Contact information

Assoc.prof. Aurel STRATAN, PhD.
 Department of Steel Structures and Structural Mechanics
 Address: Str. Ioan Curea, No. 1, RO300224, Timisoara
 Phone: (+40) 256 403 923
 Fax: (+40) 256 403 917
 E-mail: aurel.stratan@upt.ro
 Web: <http://www.ct.upt.ro/centre/cemsig/imser.htm>

LARGE VALORISATION ON SUSTAINABILITY OF STEEL STRUCTURES – LVS3

Goal of the project

During the last decade, a lot of research projects have been funded to develop methodologies, systems and products aiming at improving the thermal efficiency as well as the global environmental footprint of steel buildings. The new standard EN15804 intended for environmental calculation of buildings takes now into account the fact that steel is a recyclable material (Module D). This project summarises all this acquired knowledge into a set of documents and two software, translate them into different European languages and finally, disseminate all over Europe by organising workshops.

Short description of the project

LVS3 is a valorisation project, which aims to promote the recently developed knowledge and design methodologies concerning the environmental impact assessment of steel and composite buildings.

Project implemented by

- ArcelorMittal Belval & Differdange S.A., Luxembourg
- Politehnica University of Timisoara, Romania

Implementation period:

01.07.2013 – 15.12.2014



Main activities

The project is divided 3 main parts:

- Creation of supporting documents (background, design guide, leaflet, software, presentations);
- Translation of documents into national languages;
- Organisation of a special training for the project's partners;
- Dissemination of the knowledge into the different European countries.
- Preparation of all data for further dissemination based on HTML – web version;

In order to achieve the objectives of the projects, these different parts have been divided into six work packages, i.e.:

- WP1: Realisation of documentation and software about the environmental assessment of steel and composite buildings. All these documents and software interface have been written in English;
- WP2: Translation of the documentation and software interface;
- WP3: Training for partners involved in seminars;
- WP4: Organisation of Seminars in each of the participating countries;
- WP5: Post dissemination activities;
- WP6: Coordination.

Results

- The main results are the translation of the documents and software in Romanian language and dissemination of the knowledge by organization of a seminar in December 5th, 2014.
- The audience consists of designers, architects, developers, students and professors and last but not least the decision makers and authorities.
- During the seminar, printed documents as well as USB Keys that contain all data were distributed.
- A number of 83 participants attended the seminar.

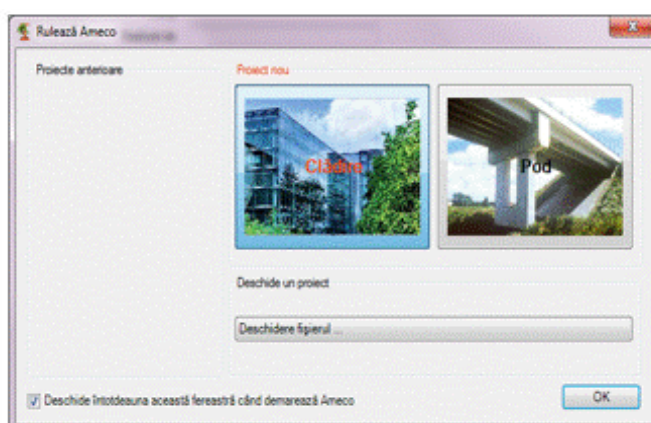

Applicability and transferability of the results

At this moment the industry and the academics have good understanding of the assessment of the environmental footprint and the improvement of the thermal efficiency of steel and composite buildings.

The added value is in the fact that the research outcomes have been presented to engineering community throughout Europe.

By translating the design guides and software into local languages, the partners will access even broader audience.

Finally, introducing the methodology in the whole Europe at the same time follows the systemised approach represented by Eurocode and EN Standards to promote homogeneous design.

Financed through/by

- Research Fund for Coal and Steel
- Total budget of "LVS" project: 376.006 €
- Budget of the Politehnica University of Timisoara: 31910 €

Research Center

The Research Centre for Mechanics of Materials and Structural Safety – CEMSIG, Politehnica University of Timisoara.

Research team

- ArcelorMittal Belval & Differdange SA (Luxembourg)
- University de Ljubljana (Slovenia)
- Ceske Vysoke Ucení Technike V Praze (Czech Republic)
- University of Athens (Greece)
- University of Timisoara (Romania)
- University of Naples Federico II (Italy)
- University of Vilnius (Lithuania)
- University of Warsaw (Poland)
- Tecnalia (Spain)
- University of Miskolc (Hungary)
- University of Coimbra (Portugal)
- University of Tallinn (Estonia)
- CTICM (France)
- University of Liège (Belgium)
- Bouwen met Staal (Netherlands)
- Stalbyggnadsinstitutet Stiftelser (Sweden)
- AC&CS – CRM Group (Belgium)
- Club Asturiano de la Innovación Asociación (Spain)

Contact information

Prof. Viorel UNGUREANU, PhD
 Department of Steel Structures and Structural Mechanics
 Address: Str. Ioan Cărea, No. 1, RO300224, Timisoara
 Phone: (+40) 256 403912
 Mobile: (+40) 740 137640
 E-mail: viorel.ungureanu@upt.ro
 Web: www.ct.upt.ro

STRUCTURAL CONCEPTION AND COLLAPSE CONTROL PERFORMANCE BASED DESIGN OF MULTISTORY STRUCTURES UNDER ACCIDENTAL ACTIONS (CODEC)

Goal of the project

The main goal of the project is the development of a performance based robustness design methodology for mitigation of progressive collapse of multi-story frame buildings against extreme load events coming from both natural and man-made hazards.

Short description of the project

Steel building structural performance and safety can be endangered due to extreme loading caused by accidental actions. Direct and indirect methods can be used in design to improve the resistance and to reduce the consequences. The project aimed to evaluate the structural components and material properties that are responsible for an improved response. Thus, different structural systems and detailing were tested experimentally under all kind of actions, i.e. static, dynamic, blast or fire, and the main response parameters have been quantified. Afterwards, numerical models were validated, as a first step to perform extensive parametric studies. When all completed, these studies will allow the development of a collapse control design methodology for reducing the consequences associated with the extreme loading events (properties damages, structural failures, fatalities).

Project implemented by

- Coordinator (CO) – Politehnica University of Timisoara
- Partner 1 (P1) - Technical University of Cluj-Napoca
- Partner 2 (P2) - URBAN-INCERC (Cluj Branch)
- Partner 3 (P3) - INSEMEX Petrosani
- Partner 4 (P4) - SC ACI SA Cluj-Napoca

Implementation period

July 2012 - June 2016

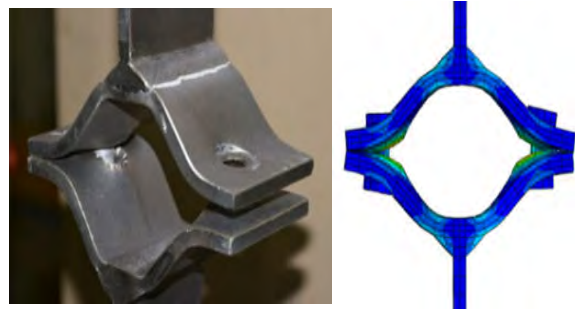

Main activities

- Preliminary investigations (Review of existing methods, identification of research needs; Preliminary analysis and selection of case study structures)
- Design of experimental and numerical simulation programs
- Experimental program on materials, weld details and connection macro-components
- Experimental program on joints (column loss scenarios and blast conditions)
- Experimental program on sub-assemblies
- Numerical simulation program
- Design guidelines and recommendations

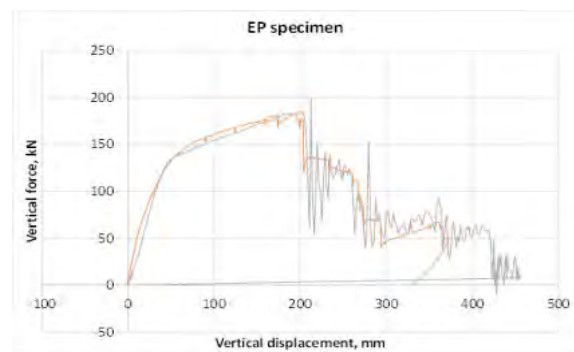

Joint specimen after the test (left) and experimental vs. numerical force-displacement curve (right)

Results

- T-stub and weld detail specimens have been tested in four different conditions: imposed displacement of 0.05mm/sec and of 10 mm/sec, combined with room temperature $T=20^{\circ}\text{C}$ and elevated temperature $T=542^{\circ}\text{C}$ conditions
- Monotonic experimental tests on joints under column loss scenarios have been performed for different connection typologies: welded (reduced beam section, cover plate) and bolted (extended end plate, extended end plate with haunch)
- Performance of two bay - two span steel frames has been studied experimentally. External links were introduced to simulate ties to the rest of the structure. Assemblies with and without reinforced concrete floor were tested.
- The direct blast effect on columns and joints was tested for intermediate and marginal columns. In the experiments different stand-off distances were employed.

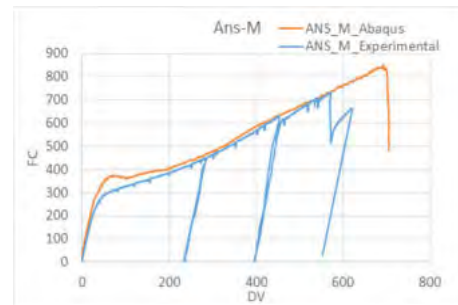
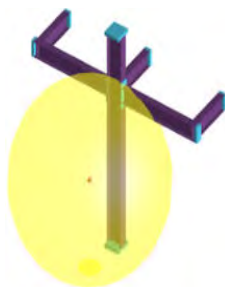

- Experimental tests on T-stub elements (top), blast T assemblies (middle) and 3D assemblies (bottom)

Applicability and transferability of the results

- Construction and design practice, code and primer manuals drafting

Financed through/by

the Executive Agency for Higher Education, Research, Development and Innovation Funding (UEFISCDI), Romania, under grant PN II PCCA 55/2012.

Research Centre

- The Research Center for Mechanics of Materials and Structural Safety – CEMSIG (www.ct.upt.ro/centre/cemsig/index.htm)

Research Team

Prof. Florea DINU, PhD (Project coordinator)
 Prof. Dan DUBINĂ, PhD
 Prof. Raul ZAHARIA, PhD
 Assoc. Prof. Adrian CIUTINA, PhD
 Assist.prof. Ioan Both, PhD
 Assist.prof. Calin NEAGU, PhD
 Ioan MĂRGINEAN, PhD Student

Contact information

Prof. Florea DINU
 Department of Steel Structures and Structural Mechanics
 Adress: str. Ioan Curea, No. 1, R0300224, Timisoara
 Phone: (+40) 256 403 912
 Mobile: (+40) 722 460 349
 E-mail: florea.dinu@upt.ro
 Web: www.ct.upt.ro/centre/cemsig/codec.htm

NEARLY ZERO ENERGY BUILDING AND PASSIVE HOUSE – SUSTAINABLE SOLUTIONS FOR RESIDENTIAL BUILDINGS

Goal of the project

The idea of this project arose from the need to develop solutions that reduce the energy consumption in the Romanian residential building sector. The main goal of the NEZEBUILD research project is related to the design and detailing of technical solutions in order to achieve the nearly zero energy building standard, resulting in the validation of such designs through extensive monitoring. Design, detailing and execution include the construction elements, finishes and installations system.

Short description of the project

In Dumbravita (near Timisoara), a house was designed and built as a duplex. Half of the duplex was designed as a passive house (PH) and the other half as a nearly zero energy building (NZEB). During the design and use of energy efficient buildings, the need arose to implement a monitoring system with a good quality/price balance, necessary in order to validate the theoretical design. The PH and NZEB are equipped with monitoring systems. Through the monitoring process of the two houses, the energy consumption is measured and thermal comfort parameters are kept under observation. The monitoring systems register data which is uploaded to a web server. The components of the monitoring systems (central units and several ambient/energy sensors) resulted from the need to make data available online and the physical measurements that had to be taken. All project activities aim at developing a recommendation design guide regarding PH an NZEB based on experimental research.

Project implemented by

- Project Partnership comprising Politehnica University of Timisoara - CCI Department and Arhitim.

Implementation period

2012 – 2016

Main activities

- Design and detailing of NZEB system including procurement of materials, equipment and elaboration of energy performance certificate for NZEB.
- Elaboration of research reports and scientific papers.
- Energy performance assessment of the passive house using the recorded data from the monitoring system.
- Execution of finishes for the NZEB, mounting of HVAC system and procurement of all the other necessary equipment.
- Design of the monitoring system and initiation of the monitoring activities for the NZEB.
- Elaborating a comparative PH vs. NZEB study on energy efficiency; optimization of global cost for NZEB;
- life-cycle assessment of NZEB.
- Dissemination of recommendations and general rules for implementing energy efficient residential houses in temperate climate.



a) Normal image



b) Thermal image

Fig. 1 General view of house

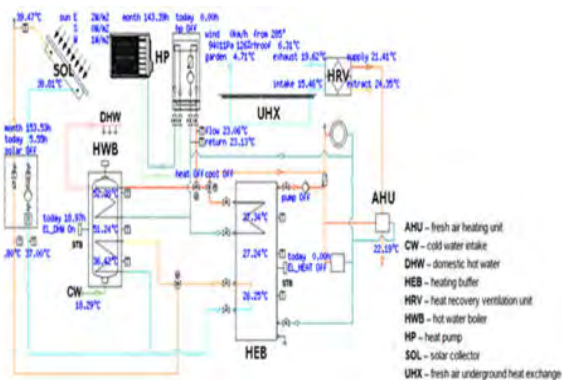

a) Passive house

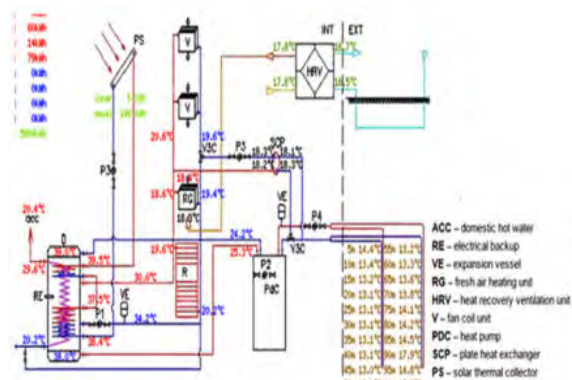

b) Nearly zero energy building

Fig. 2 Schematic representation of the buildings services

Results

Currently, the most relevant results consist in:

1. validation, verification and centralization of data obtained through the monitoring systems;
2. analysis of the monitoring data and energy certification based on actual measured energy consumption of PH;
3. completion of the finishing and equipping works on the NZEB;
4. installation of the monitoring system and initiation of the monitoring for NZEB;
5. evaluation of the energy consumption for the NZEB, registered since the initiation of the monitoring process (January 2014);
6. monitoring and evaluation of the energy produced by the solar photovoltaic panels installed for the NZEB;
7. elaboration of a comparative study between the PH and the NZEB in order to identify the advantages and disadvantages that characterize each type of house.

Applicability and transferability of the results

The topic of the project is closely related with the increasing concern of nowadays society on reducing the energy consumption in buildings. The targeted groups of the project are scientist, specialists in the energy efficiency field and stakeholders. The project deliverables will assure the transfer of knowledge, generating further „know-how“ for scientific community and for practicing specialists (civil and environmental engineers, electrical and energy engineers, architects, technicians).

Financed through/by

UEFISCDI, project number PN-II-PT-PCCA-2011-3-2-1214-Contract 74/2012.

Research Centre

- Research Centre for Retrofitting of Constructions – RECO
- CCI Department

Research Team

Prof. Daniel DAN, PhD - Project Manager

UPT TEAM MEMBERS

Prof. Valeriu STOIAN, PhD

Assist. Lecturer Tamas NAGY-GYORGY, PhD

As. Sorin-Codrut FLORUT, PhD

As. Eng. Cosmin DAESCU, PhD

Eng. Simon PESCARLI, PhD student

As. Calin SEBARCHEVICI, PhD

ARHITIM TEAM MEMBERS

Arh. Dan STOIAN, PhD student

Eng. Cristina TANASA, PhD student

Contact information

Prof. Daniel DAN, PhD

Department of Civil Engineering and Building Services

Address: Str. Traian Lalescu, No.2, RO300223, Timisoara

Phone: (+40) 256 403 005

E-mail: daniel.dan@upt.ro

CHALLENGE – ADDRESSING THE FOUR KEY CHALLENGES OF SUSTAINABLE URBAN MOBILITY PLANNING

Goal of the project

Achieving sustainable, energy-efficient and environmentally friendly transport systems is one of the European key aims. Sustainable Urban Mobility Plans (SUMPs) are an instrument that contributes to reaching the climate and energy targets set by EU leaders and is promoted by the European Commission in relevant documents such as the Transport White Paper and Action Plan on Urban Mobility. Cities frequently face major barriers while creating their own Sustainable Urban Mobility Plans.

Short description of the project

In CHALLENGE (2013-2016), nine European cities, and eight supporting organisations have teamed up for overcoming the four most pressing challenges in sustainable urban mobility planning:

- Stakeholder participation and citizen involvement
- Institutional cooperation between sectors and disciplines
- Identification of the most effective policy measures
- Monitoring and evaluation of progress in SUMP development

For each challenge, the project cities analyze their local mobility situation, develop new strategies how to tackle their urban mobility problems and test solutions to overcome barriers in participation, cooperation, measure selection as well as monitoring and evaluation in more than forty pilot schemes.

Based on the lessons learned from the pilot schemes in the nine participating project cities, on the experience from the Follower Cities and on the results from the training activities, four CHALLENGE Kits will be developed as the main outputs of the project. Each kit will address one challenge and will consist of a comprehensive manual, a brochure and the relevant e-learning modules. The kits will be available in English, Czech, Croatian, Dutch, French, German, Hungarian, Polish and Romanian.

Both, cities with a lot of experience with integrated planning approaches and cities initiating the SUMP process will benefit from the results of CHALLENGE.



Implementation period

2013-2016

Main activities

- CHALLENGE will produce four practical CHALLENGE kits covering the identified SUMP challenges: participation of stakeholders, institutional cooperation, Identification of most effective measures and monitoring and evaluation. The kits will consist of a comprehensive manual, a quick-facts brochure and the relevant e-learning modules aimed at local practitioners and will guide you through participation processes, institutional cooperation, measure selection as well as monitoring and evaluation procedures;
- Four interactive SUMP Challenge Training Workshops are held for local planners and decision-makers. In addition, National SUMP Seminars and Summer Schools are organized in the Czech Republic, Croatia, Hungary, Poland and Romania.
- Learn with us online by registering for our free Online Learning Courses and benefit from the results of the workshops and seminars as well as the experiences from the CHALLENGE cities.



Financed through/by

IEE – Intelligent Energy Europe Programme of the European Union.

Project implemented by

The CH4ALLENGE cities:

- Amiens (France)
- BKK Centre for Budapest Transport (Hungary)
- Brno (Czech Republic)
- Dresden (Germany)
- Ghent (Belgium)
- Krakow (Poland)
- Timisoara (Romania)
- West Yorkshire Passenger Transport Executive, WYPTE (METRO) – Leeds (UK)
- Zagreb (Croatia)

SUMP Knowledge Partners:

1. Rupprecht Consult, Forschung & Beratung GmbH (Lead Partner) – Cologne (Germany)
2. The Association for Urban Transition, ATU – Bucharest (Romania)
3. Forschungsgesellschaft Mobilität - Austrian Mobility Research FGM – AMOR – Graz (Austria)
4. Institute for Transport Studies (ITS)
5. University of Leeds (UK)
6. Polis – European Cities and Regions Networking for Innovative Solutions – Brussels (Belgium)
7. Politehnica University of Timisoara (Romania)
8. Union of the Baltic Cities Commission on Environment UBC – Turku (Finland)
9. Urban Planning Institute of the Republic of Slovenia, UIRS – Ljubljana (Slovenia)

Research team

Associate Prof. Dumitru IANLULUI, PhD
Senior Lecturer Attila GONCZI, PhD

Contact information

Attila Iuliu GÖNCZI, PhD
Department of Mechanical Machines, Technology and Transportation
Address: Str. Remus, No. 14, 300191 Timisoara
Phone: (+40) 256 404 291
Mobile (+40) 740 073 951
E-mail: attila.gonczi@upt.ro
Web: <http://www.sump-challenges.eu/>

HIGH MAGNETIZATION MAGNETIC NANOFUIDS AND NAO-MICRO-COMPOSITE MAGNETIZABLE FLUIDS: APPLICATIONS IN HEAVY DUTY ROTATING SEALS AND MAGNETORHEOLOGICAL DEVICES

Goal of the project

The project is oriented to the extension of the performances of rotating seals and adaptive motion control devices to meet the requirements of several well-defined new applications, by high and very high magnetization sealing fluids and new types of magnetorheological fluids to be synthesized.

Short description of the project

The project concept and objectives are illustrated schematically in figure the below:

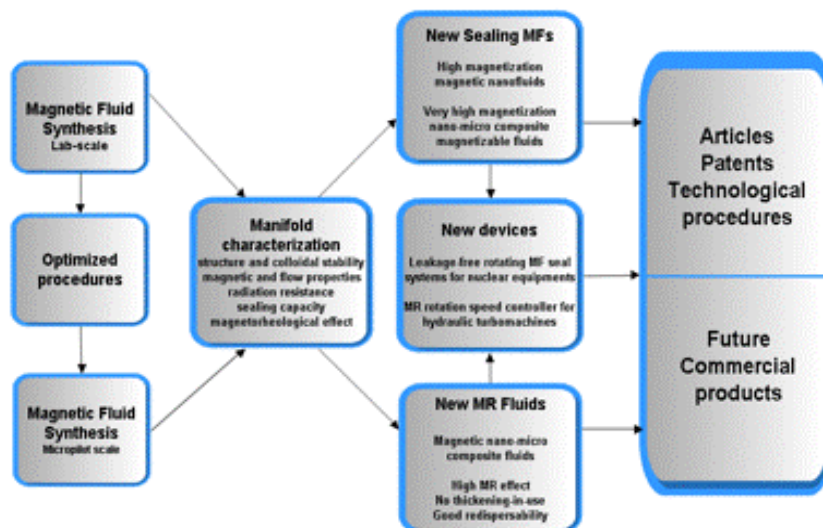

Project implemented by

- Romanian Academy – Timisoara Branch (Project coordinator),
- Politehnica University of Timisoara (Partner 1),
- S.C. ROSEAL S.A. Odorheiu Secuiesc (Partner 2)
- National Institute for R&D in Electrical Engineering ICPE-CA Bucharest (Partner 3).

Implementation period

23.07.2012 - 23.07. 2016.

Main activities

The main activities of the MagNanoMicroSeal project are:

- Synthesis and manifold characterization of magnetizable fluids for high pressure and heavy duty rotating seals and magnetorheological devices and, respectively,

- Design, fabrication and testing of leakage – free magnetofluidic rotating seal and magnetorheological (MR) control devices for well-defined applications/exploitation conditions.

Results

The main results of this project refer to the elaboration of the following **technological procedures**:

- synthesis of high magnetization sealing fluids;
- synthesis of nano-micro structured magnetorheological fluids;

and **qualification procedures**:

- magnetic nanofluids for sealing applications in nuclear equipments;
- magnetic nanofluids for rotating seals for nuclear equipments.

The contributions of Politehnica University of Timisoara to this project refer mainly to complex magnetic, rheological and magneto-rheological analyses of the magnetic sealing fluids and nano-micro structured magnetorheological fluids.



Mechanical – magnetofluidic tandem rotating seal for compressors and liquified gas pumps (functional model)
(Partner 2 – S.C. ROSEAL S.A.)

Applicability and transferability of the results

The technological progress is strongly evidenced by future commercial products planned for the industrial partner S.C. ROSEAL S.A.: 16 new types of magnetically controllable fluids, 1 prototype and 3 functional models of magnetofluidic devices for nuclear and hydraulic power engineering.

Financed through/by

Ministry of National Education through the Executive Agency for Higher Education, Research, Development and Innovation Funding, Partnerships in priority S&T domains Programm PN II, Collaborative Applied Research Projects PCCA 2011 – UEFISCDI

Research centre

- Research Center for Engineering of Systems with Complex Fluids, Politehnica University of Timisoara
- Magnetometry Laboratory, Rheology Laboratory, Numerical Simulation and Parallel Computing Laboratory
- URL: <http://mh.mec.upt.ro/ccisfc/>

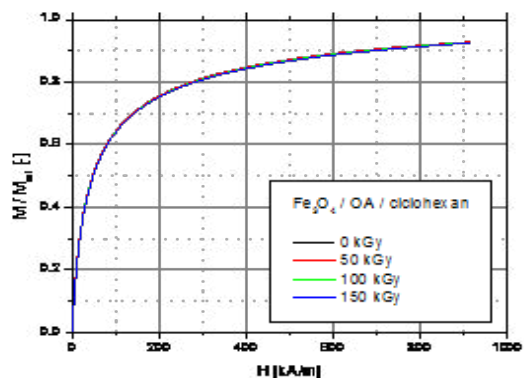

Magnetization curves for non-/ irradiated MF/cyclohexane (OA)
(Partner 1 – Politehnica University of Timisoara)

Research team

The project research team consists of 42 researchers, engineers and technicians

Dr. Ladislau VEKAS – the project manager
 Assoc.Prof. Floriana D. STOIAN, PhD
 Phys. Oana MARINICA
 Lect. Sorin HOLOTESCU, PhD
 Assoc. Prof. Nicolae CRAINIC, PhD
 Lect. Andreea DOBRA, PhD
 Lect. Adelina HAN, PhD
 Res. Assist. Florica BALANEAN
 Res. Assist. George GIULA.

Contact information

Dr. Ladislau VÉKÁS
 e-mail: vekas@acad-tim.tm.edu.ro; vekas.ladislau@gmail.com
 Tel.: (+40) 256 403 700; (+40) 256 403 703
 Fax: (+40) 256 403 700

Assoc. Prof. Floriana D. STOIAN, PhD
 Department of Mechanical Machines, Technology and Transportation
 /Research Center for Engineering of Systems with Complex Fluids
 Address: Bv. Mihai Viteazu, No.1, 300222. Timisoara
 Phone: (+40) 256 403 671
 Mobile: (+40) 744 597 308
 E-mail: floriana.stoian@upt.ro
 Web: <http://acad-tim.tm.edu.ro/magnanomicroreal/>

ENVIRONMENTAL ENERGY HARVESTING HYBRID SYSTEM BY PHOTOVOLTAIC AND PIEZOELECTRIC CONVERSION, DC/DC TRANSFORMATION WITH MEMS INTEGRATION AND ADAPTIVE STORAGE

Goal of the project

The design and testing of the prototype of a hybrid system for energy harvesting from the ambient through photovoltaic conversion, DC/DC transformation with MEMS integration and adaptive storage, will be carried out. A key novel component is the planar power micro-transformer for high frequency, with hybrid magnetic nanofluid/ferrite core and windings fabricated in MEMS technology, a part of the DC/DC converter. A second key component is the photovoltaic cell, which relies on novel solutions.

Short description of the project

A prototype with wireless sensors powered by the harvesting system will be designed and tested.

Project implemented by

- National Institute for R&D in Electrical Engineering ICPE-CA Bucharest (Coordinator)
- Politehnica University of Timisoara (Partner 1)
- Romanian Academy – Timisoara Branch (Partner 2)
- Politehnica University of Bucharest (Partner 3)
- SYSCOM PROCESS CONTROL LTD (Partner 4).

Implementation period

01.07.2014 – 30.06.2016

Main activities

- elaboration of the experimental model of the energy harvesting hybrid system by photovoltaic conversion and DC/DC transformation with MEMS integration;
- design and testing of the experimental model of the energy harvesting hybrid system by photovoltaic conversion and DC/DC transformation with MEMS integration;
- design and testing of the prototype of the energy harvesting hybrid system by photovoltaic conversion and DC/DC transformation with MEMS integration.

Results

- The main result of the project will be the integration of an innovative photovoltaic conversion system and an original DC/DC converter, which utilizes a planar, spiral, MEMS, hybrid (magnetic nanofluid/ferrite) cored micro-transformer in an efficient device for energy harvesting.
- Regarding the use of a magnetic nanofluid core micro-transformer for the DC/DC converter, from the manufacturing point of view, it is expected that once the appropriate magnetic nanofluid characteristics are established, it will offer an easier way of obtaining the transformer core compared to a solid one.

- From the operating point of view, it is expected that by replacing the solid core with a liquid core will result in a better heat dissipation and reduction of the thermal stresses in the micro-transformer, leading to a longer life-cycle, maintaining or even improving the electric characteristics.

Applicability and transferability of the results

The product can bring added value for further development as an end-product to the industrial partner. Possible applications are characterized by their placement in hard to reach places, isolated and without local and/or conventional sources. Among these are applications for industrial automation, monitoring of various parameters in industry, agriculture, surveillance and monitoring of perimeters.

Financed through/by

UEFISCDI, Partnerships in priority S& T domains Program PN II, Joint Applied Research Projects PCCA 2013.

Research centre

Research Center for Engineering of Systems with Complex Fluids, Politehnica University of Timisoara

Research team

Assoc. Prof. Floriana D. STOIAN, PhD
Lect. Sorin HOLOTESCU, PhD
Phys. Oana MARINICA
Assoc. Prof. Nicolae Crainic, PhD
Res. Assist. Florica BALANEAN
Res. Assist. George GIULA

Contact information

Assoc. Prof. Floriana D. STOIAN, PhD
Department of Mechanical Machines, Technology and Transportation /Research Center for Engineering of Systems with Complex Fluids
Address: Bv. Mihai Viteazu, No.1, 300222. Timisoara
Phone: (+40) 256 403 671
Mobile: (+40) 744 597 308
E-mail: floriana.stoian@upt.ro
Web: <http://www.icpe-ca.ro/lib/files/aseMEMS-harvest.pdf>

IMPROVEMENT OF THE TITANIUM WEAR RESISTANCE BY ELECTRON BEAM REMELTING OF THE PRE-DEPOSITED THERMAL

Goal of the project

Improvement of the exploitation performance of the titanium, especially wear behavior, without influencing its good corrosion resistance.

Short description of the project

Titanium is one of the most promising metals in field of high specific strength engineering. Although it offers attractive mechanical, chemical and physical properties, its surface properties are deficient, possessing poor fretting fatigue resistance and poor wear resistance properties. Thermal spray coatings is one of the most common ways to improve the surface characteristics of the materials being used in a wide range of industries to improve the abrasive, erosive, and sliding wear of machine components.

The proposed theme focuses on the improving of the titanium wear resistance by electron beam (EB) remelting of the pre-deposited oxidic powder Al₂O₃-TiO₂ using the high velocity oxygen fuel (HVOF) and atmospheric plasma spraying (APS) methods. The EB treatment may lead to the elimination of porosity, enhancement of the coating strength and chemical homogeneity, and the development of metallurgical bonding at the coating-substrate interface producing strengthened coatings adhesion.

Main activities

1. State of the art and perspectives evaluation in surface coatings technique used as a method in order to improve the wear behavior of the titanium;
2. Development of HVOF and APS sprayed Al₂O₃-TiO₂ coatings on the surface of titanium and their remelting using the electron beam (EB) method;
3. Analysis and characterization of the obtained HVOF sprayed Al₂O₃-TiO₂ coatings before and after the electron beam remelting treatment;
4. Study of the wear and corrosion behavior of the coatings before and after the electron beam remelting;

Results

- Deposition of the Al₂O₃-TiO₂ coatings using the HVOF and APS spraying methods on the surface of a titanium substrate
- Electron beam remelting of the pre-deposited Al₂O₃-TiO₂ coatings

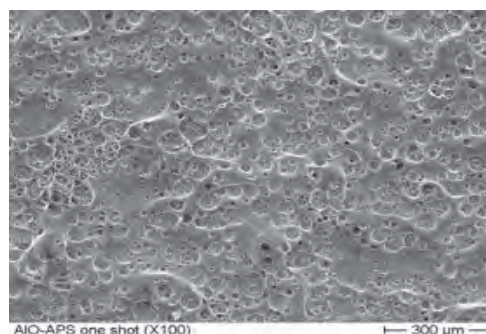
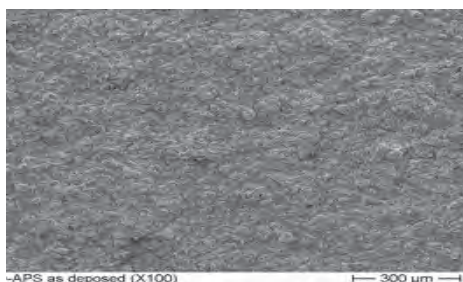

Project implemented by

Politehnica University of Timisoara

Implementation period

02.09.2013-30.09.2016

Applicability and transferability of the results

The results which will be obtained in frame of the project will be transferred to companies in the field of automotive industry and not only. Also they will be presented to national and international conferences and published in scientific journals.

Research Centre

Research Centre for Processing and Characterization of Advanced Materials

Financed through/by

UEFISCDI - Executive Unit For Financing Education Higher Research Development And Innovation

Research team

Ion-Drăgos UTU - Project manager
Viorel-Aurel SERBAN - senior researcher
Cosmin CODREAN - senior researcher
Carmen OPRIS - senior researcher
Iosif HULKA - postdoc researcher

Contact information

Lecturer Ion-Drăgos UȚU, PhD
Department of Materials and Manufacturing Engineering
Address: Bv. Mihai Viteazu, No.1, 300222. Timisoara
Phone: (+40) 256 403 656
E-mail: dragos.utu@upt.ro

SUSTAINABLE DEVELOPMENT OF A RESEARCH CENTER IN BANAT REGION AND DANUBE FLOW AREA THROUGH SCIENTIFIC RESEARCH AND ENVIRONMENTAL SIMULATION TOOLS TO ASSES AND EVALUATE POTENTIAL THREATS. ACRONYM: ENVIROBANAT

Goal of the project

Strengthening the cross border cooperation in Banat region, development of two state-of-the-art research laboratories in the field of environmental protection and contribution to the development and increase visibility of regional scientific research actors and opportunities.

Short description of the project

We started the project having in mind the improvement of the quality of life for communities in Banat region and increasing the overall competitiveness of research capabilities and visibility in cross border area. It this century development without environmental concern isn't possible as we should think about sustainable actions only. In this respect, the Envirobanat project comes to support NGO's, industries and societies with valid, relevant and accessible data regarding current state of air and surface water quality in Banat region, with high resolution scientific equipment's and relevant research capabilities, both in manpower and research infrastructure and with well-trained experts.

Project implemented by

- Politehnica University of Timisoara
- University of Novi Sad, Technical Faculty "Mihajlo Pupin" Zrenjanin

Implementation period

12.06.2013 – 11.06.14

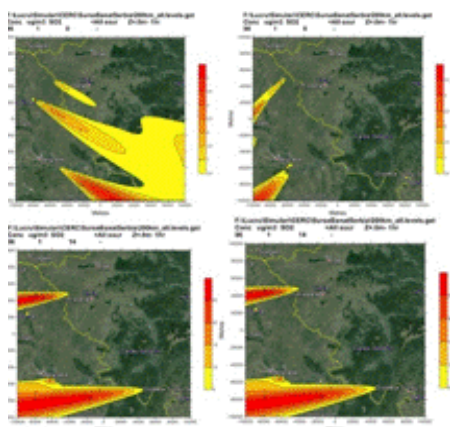

Main activities

- In-situ monitoring of surface water quality on Danube and its main tributaries (pH, nitrite/nitrate, COD/DO, Fe, Phosphor, suspended matter);
- Collection of air quality data from over 10 continuous air quality monitoring stations in Romanian and Serbian Banat regions;

- In-situ monitoring of airborne particles, concentration and aerodynamic sizing in the range of 0.3 ÷ 20 µm;
- Organizing two major scientific conferences, one in Timisoara and one in Zrenjanin;
- Organizing training sessions for knowledge transfer (air quality dispersion tools, PM10 sizing and monitoring techniques) for Serbian students and experts
- Realization of several studies for air pollutants dispersion in Banat area from relevant industrial sources in the region.

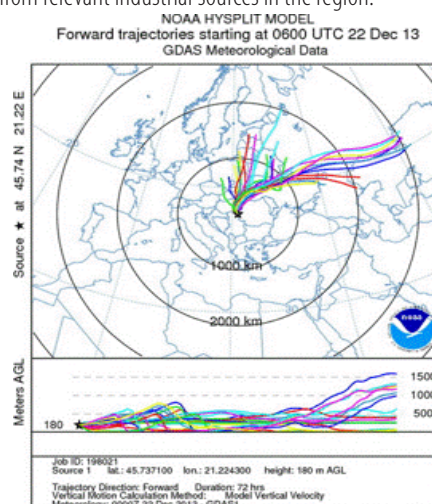

Results

- Creation and development of an extensive air – NO/NO₂, CO, SO₂, benzene, toluene, xylene, particle concentration (PM₁₀, PM₄, PM_{2.5} & PM₁), mass distribution and size distribution (0.3 ÷ 20 µm) – and surface water quality parameters (pH, NO₂⁻, NO₃⁻, P, suspended matter, BOD, COD, DO) for Banat region and Danube tributaries, downloadable from www.envirobanat.ro;
- Acquisition of high-end/high resolution equipment's for air and water quality research;
- Extensive training of 15 Serbian students in the use of Cambridge Environmental Research ADMS5 and ADMS Road atmospheric dispersion modelling systems;
- Extensive training of 12 Serbian students in the use of PHOENICS – computation fluid dynamics software for environmental studies;
- Extensive training of 19 Romanian students in the use of GRIMM instruments – Application of laser diffraction particle sizing;
- Organization of two regional conferences, in Zrenjanin and Timisoara;

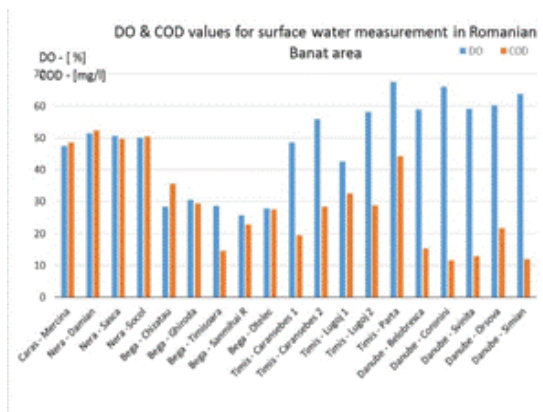
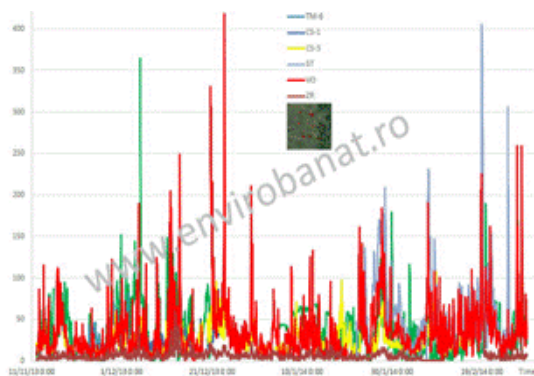

Applicability and transferability of the results

All obtained results are available for download via project webpage www.envirobanat.ro, in form of individual files, pdf or database. The project outputs provides significant tools to support local and regional universities, NGOs and authorities in their effort to contribute to regional economic growth by means of durable medium and long term development strategies.

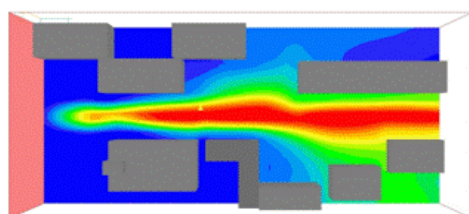

Financed through/by

European Union / IPA CBC Programme

Research team

Popescu FRANCISC
 Dorin LELEA
 Ioan LAZA
 Gavrilă TRIF-TORDAI
 Adrian Eugen CIOABLĂ
 Olivia BUNDĂU
 Marinela BĂLUȚ
 Gavril BRĂTEANU
 TFMP: Milan PAVLOVIC, Aleksandar DJURIC, Bogdana VUJIC, Milan NIKOLIC, Marko SIMIC, Branko DAVIDOVIC, Aleksandar PAVLOVIC, Dejan DJORDJEVIC.

Contact information

Assist. Prof. Francisc POPESCU, PhD
 Department of Mechanical Machinery, Equipment and Transportation
 Address: Bv. Mihai Viteazu no.1, RO300222, Timisoara
 Phone: (+40) 256 403 666
 Mobile: (+40) 721 832 730
 E-mail: francisc.popescu@upt.ro
 Web: www.envirobanat.ro

NUTRITIONAL LABELING STUDY IN BLACK SEA REGION COUNTRIES - NUTRILAB

Goal of the project

- Bring together, review and analyze current research on consumer understanding of claims, and also labeling where this would inform our knowledge of consumer understanding of claims.
- Gather information on how consumer understanding of claims varies across different population groups, to gain insight into the understanding of the 'average consumer'.
- Draw conclusions from existing research to see whether there are areas where further information would be useful, and to inform the direction that any additional research conducted in future could take. A strong component in this framework will be the capacity building. It will explicitly aim to identify and integrate the different and overlapping conceptual understandings of scientists from the different disciplines carrying out joined research in this project.

Short description of the project

This multidisciplinary and comparative Joint Exchange programme will identify and examine how nutritional labeling in European countries and out of Europe can influence on health and welfare of population. Health professionals agree that the relationship between diet and health is important. Our eating habits can help or hurt our overall health and well-being. Good eating habits include being a smart shopper and selecting foods that reflect the Dietary Guidelines. The food label was designed to help people choose foods for a healthful diet. By using the food label, we can compare the nutrient content of similar foods, see how foods fit into our overall diets, and understand the relationship between certain nutrients and diseases.



Project implemented by

- Institute of Microbiology and Biotechnology, Academy of Sciences of Moldova (IMB), Moldova
- Politehnica University of Timișoara (UPT), Romania
- University of Food Technologies (UFT), Bulgaria
- Fundatia pentru Cultura si Invatamant "Ioan Slavici", Romania
- Lucian Balaga University of Sibiu (ULBS), Romania
- University of Rousse Angel Kanchev (UR), Bulgaria
- Transilvania University of Brasov (UNITBV), Romania
- Technical university of Moldova (TUM) Moldova
- Donetsk National University Economics and Trade named after M. Tugan-Baranovsky (DONNUET), Ukraine
- Kharkiv State University for Food Technologies and Trade (KSUFT), Ukraine
- National University of Food Technologies, (NUFT), Ukraine
- St. Petersburg State Institute of Technology (Technical University) (SIT), Russian Federation

Implementation period

01.01.2013 – 31.12.2015

Main activities

1. Integrate experiences from consortium countries into NUTRILAB project development;
2. Provide guidelines for sampling and administration;
3. Translate the NUTRILAB results and questioners from English to the language instruction in the respective countries;
4. Coordinate the NUTRILAB data collection for all consortium countries and partners and other participating countries;
5. Relevant theories, findings and methodology, and provide an overview of previous similar surveys to aid instrument development;
6. Collect data in each NUTRILAB consortium country.
7. data collection will be defined in different steps:
 - definition of keywords for search engines;
 - Web-browsing;
 - Compile a report/book towards the end of the project.

Results

- NUTRILAB seasonal schools which provide within a reasonably compact timeframe as a thorough and exhaustive treatment as possible of various topics in food labeling, but from a particular angle in each case
- Second North and East European Congress on Food (NEEFood-2013) which was held on May 26-29 2013 on the premises of the National University of Food Technologies

Applicability and transferability of the results

- Review of EU and national action plans, papers surveys;
- Review of EU and national R&D projects and programmes;
- Code and clean the national data files (all partners);
- Merge the national data files into the international data file, and clean it;
- Conduct general overall comparative data analysis and sum up findings from the project at large;



Financed through/by

Project number: 318946 - FP7-PEOPLE - 2012 - IRSES



Research team

Dumitru TUCU
Dumitru MNERIE
Titus SLAVICI
Petru ANDEA
Hannelore FILIPESCU
Nicolae LONTIS
Marinela BALUT

Contact information

Prof. Dumitru TUCU, PhD
Department for Mechanical Machines, Equipment and Transportation
Bd. Mihai Viteazul, No.1, RO300222, Timisoara
Phone: (+40) 256 403 601;
Mobile: (+40) 744 264 650;
E-mail: dumitru.tucu@upt.ro
Web: <http://www.rosita.ro/nutrilab/news.html>

NOVEL TECHNIQUE TO ENHANCE THE SECURING LEVEL OF SECURITY PAPER USING THE SUPERPARAMAGNETIC FINGERPRINT OF MAGNETIC NANOPARTICLE DISPERSIONS → NANOMAG-SECURITY PAPER

Goal of the project

Security paper is among the most important ingredients used in the fight against the forgery of private or public documents. The continuous diversification and sophistication of the paper securing techniques is one of the most important ways to erect fences against forgery attempts. The NanoMagSecurityPaper project aims to expand the diversity of high tech means for paper securing. The general objective of the project is to elaborate a new paper securing technique based on the superparamagnetic fingerprint of magnetic nanoparticles made of oxide compounds.

Short description of the project

The objective of the project is to elaborate a new paper securing technique based on the superparamagnetic fingerprint of the magnetic nanoparticles.

Project implemented by

- Romanian Academy – Timisoara Branch (CO)
- SC CEPROHART SA (P1)
- SC ROSEAL SA Odorheiu Secuiesc (P2)
- SC Datronic – NCIP SRL (P3)
- National Institute of R&D for Izotopic and Molecular Technologies Cluj-Napoca (P4)
- Politehnica University of Timisoara (P5).

Implementation period

01.07. 2014 – 30.06.2016

Main activities

1. to elaborate superparamagnetic paper assortments with
 - 1.1 low security level, using polydisperse magnetic nanoparticles,
 - 1.2 high security level, using bidisperse magnetic nanoparticles, an
 - 1.3 white color, using core-shell (core/magnetic, shell/polymer) particles.
2. to elaborate and test the authentication method using the magnetogranulometry technique applied to
 - 2.1 static magnetometry
 - 2.2 dynamic magnetometry.

Results

1. Synthesis and magneto-optic characterization of monolayer stabilized magnetic nanoparticles with oleic acid
2. Synthesis and magnetic, TEM and FTIR characterization of magnetic nanocomposites embedded in three type of oxide matrices:
 - SiO₂ based magnetic nanocomposites;
 - TiO₂ based magnetic nanocomposites;
 - ZnO based magnetic nanocomposites.

Applicability and transferability of the results

The new method of securing paper using the superparamagnetic nanoparticles can be transferred to SC Ceprohart SA Braila. The transfer will contribute to:

- diversification of the product made in the national paper industry with simple brown paper secure and secure complex white paper,
- orientation of national industry to obtain a special paper grade with high complexity,
- increase the security level of specialty papers, difficult to fake on the internal market
- reduce the imports of security paper
- increase output and thus sales of security paper from Ceprohart.

Financed through/by

UEFISCDI

Research centre

Research Centre for Engineering of Systems with Complex Fluids – Laboratory of Rheology and Magnetometry, from Politehnica University of Timisoara.

Research team

Dr. Vlad SOCOLIUC, the director of the NanoMagSecurityPaper project
 Phys. Oana MARINICA
 Dr. Phys. Aurel ERCUTA
 Dr. Phys. Catalin MARIN
 Res. Assist. Florica BĂLĂNEAN
 Res. Assist. George GIULA.

Contact information

Phys. Oana MARINICA
 Research Center for Engineering of Systems with Complex Fluids,
 Laboratory of Rheology and Magnetometry
 Bd. Mihai Viteazu No. 1, RO300223, Timisoara,
 Tel.: (+40) 256 403700; (+40) 256 403701
 Fax: (+40) 256 403700
 E-mail: attila.gonczy@upt.ro
 Web: <http://mh.mec.upt.ro/ccisfc/>
 Dr. Vlad SOCOLIUC
 Romanian Academy – Timisoara Branch
 e-mail: vsocoliuc@gmail.com

HISPEED NANO MAG SEAL

Goal of the project

The project technical objective is to achieve at experimental model scale new leakage-free MNF sealing systems for high peripheral speeds (up to 30 – 70 m·s⁻¹) in the sealing area, designed to equip gas turbocompressors.

Short description of the project

The project proposes the development of magnetic nanofluid (MNF) seals which has significant advantages compared to conventional mechanical seals: hermetic sealing, exceptionally long lasting operation without intervention (~ 5 years), minimal wear (only viscous friction), virtually zero contamination, optimal torque transmission, wide operating range (10⁻⁸ mbar - 10 bar), relatively simple and cost efficient execution.

Project implemented by

- SC ROSEAL SA Odorheiu Secuiesc (CO)
- Romanian Academy – Timisoara Branch (P1)
- National Institute of R&D for Izotopic and Molecular Technologies Cluj-Napoca (P2)
- Politehnica University of Timisoara (P3)
- Romanina Research and Development Institute for Gas Turbines – COMOTI Bucharest (P4).

Implementation period

01. 07. 2014 – 30. 06. 2016

Main activities:

1. Laboratory and micropilot scale synthesis of magnetic nanofluids with carboxylic stabilizers and magnetizations between 400-1000 G. Samples characterization.
2. Conception, design and implementation of new experimental models of sealing systems with magnetic nanofluid, for high peripheral speeds
3. Testing and performance evaluation of new experimental models sealing systems with magnetic nanofluid, designed for high peripheral speeds

Results

Establishment of the laboratory scale methods for synthesis and characterization of magnetic nanofluids with carboxylic stabilizers and magnetization values between 400-1000 G.

Applicability and transferability of the results

The expected results will facilitate design and low cost industrial scale production of an original sealing system with stable MNF at high temperatures (160 – 180 °C), for high peripheral speeds (up to 30 – 70 m·s⁻¹) in the sealing gap. They have some important advantages compared to conventional mechanical seals: hermetic sealing, high reliability, relatively simple construction, low execution cost. These performances indicate the market towards ROSEAL Co. is heading, namely the gas turbocompressors in fertilizer and petroleum refining industry.

Financed through/by

the Ministry of Education, Research, Youth and Sports (MECTS) – Executive Unit for Financing Higher Education, Research, Development and Innovation (UEFISCDI) through the PN II Program Partnerships in Priority Areas, Collaborative applied research projects.

Research Centre

Research Centre for Engineering of Systems with Complex Fluids – Laboratory of Rheology and Magnetometry, from Politehnica University of Timisoara.

Research team

Tunde BORBATH, PhD – the director of the HiSpeedNanoMagSeal project (Romanian Academy – Timisoara Branch)
The Politehnica University of Timisoara (P3) research team in this project consist of 3 researchers and 2 research assistants, as follows:
Phys. Oana MARINICA
Assoc. Prof. Floriana D. STOIAN, PhD
Assoc. Prof. Nicolae CRAINIC, PhD
Res. Assist. Florica BALANEAN
Res. Assist. George GIULA

Contact information

Phys. Oana MARINICA
Center for Engineering of Systems with Complex Fluids, Laboratory of Rheology and Magnetometry
Address: Bd. Mihai Viteazu, No.1, R0300222, Timisoara
Phone: (+40) 256 403700; (+40) 256 403701
Fax: (+40) 256 403700
E-mail: oana.marinica@upt.ro;
Web: <http://www.roseal.eu/HiSpeedNanoMagSeal/etape.html>

MICRO-MECHANICAL MODELLING OF CELLULAR MATERIALS WITH REFINEMENTS ON FRACTURE AND DAMAGE

Goal of the project

Cellular materials are widely used as cores in sandwich composites, for packing and cushioning. The main characteristics of foams are light weight, high porosity, high crushability and good energy absorption capacity. Present project propose to develop micro-mechanical models in order to predict the mechanical properties of cellular materials with a focus on modeling the fracture and the influence of damage on the mechanical response.

Short description of the project

Project combines analytical methods, with numerical micro-mechanical finite element analysis and experimental investigations: materials testing and investigating the damage mechanisms by Digital Image Correlation and Thermoelastic Stress Analysis. The novelty of the project will be highlighted by the size and notch effect for cellular materials, and by investigating the effect of microstructural damage on the mechanical response of cellular materials.

Project implemented by

- Politehnica University of Timisoara
- Lublin University of Technology, Lublin, Poland
- Slovak Academy of Science, Bratislava, Slovakia
- Polymer Competence Center Leoben, Austria
- ILK, TU Dresden, Germany

Implementation period

05.10.2011 – 04.10. 2015

Main activities

- Better understanding of mechanical behavior of cellular materials.
- Develop micro-mechanical models to estimate mechanical properties of cellular materials.
- Implementation of constitutive material models in Finite Element Analysis.
- Investigating the size effect and notch effect on cellular materials Evaluating the behavior of cellular materials under dynamic (impact and fatigue) loading.
- Identification of damage mechanisms in cellular materials.
- Investigating the effect of microstructural damage on the mechanical properties of cellular materials.

Financed through/by

Grant PN-II-ID-PCE-2011-3-0456, Contract Nr. 172/2011, by Romanian Ministry of National Education, through UEFISCDI

Investigating the damage of PUR foams with different densities and holes

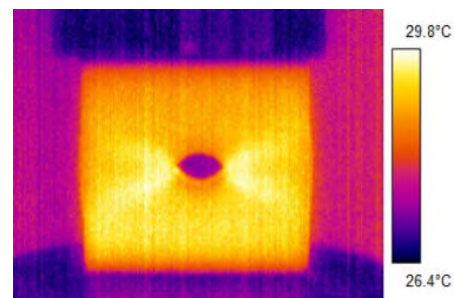

by thermography

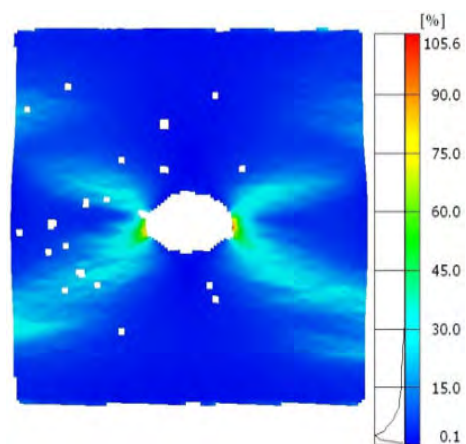

by Digital Image Correlation

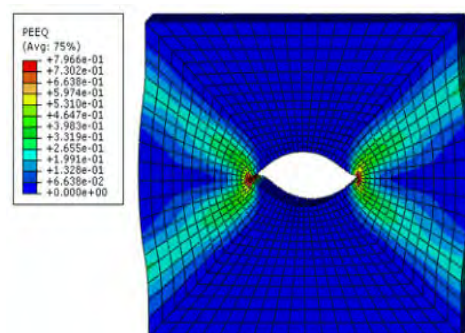

by Finite Element Method (equivalent plastic strain)

Main results for 2014 year:

Journal Papers:

1. L. Marsavina, D.M. Constantinescu, E. Linul, D.A. Apostol, T. Voiconi, T. Sadowski, Refinements on fracture toughness of PUR foams, *Engineering Fracture Mechanics*, 129, 54-66, 2014, DOI: 10.1016/j.engfracmech.2013 (ISI);
2. T. Voiconi, R. Negru, E. Linul, L. Marsavina, H. Filipescu, The notch effect on fracture on polyurethane materials, *Frattura ed Integrita Strutturale*, 30, 101-108, 2014 (SCOPUS);

Conference Papers:

1. L. Marsavina, E. Linul, T. Voiconi, R. Negru, Experimental investigations and numerical simulations of notch effect in cellular plastic materials, The 3rd International Conference on Competitive Materials and Technology Processes, Miskolc, Hungary, 2014;
2. E. Linul, T. Voiconi, L. Marsavina, Determination of Mixed Mode Fracture Toughness of PUR foams, *New Trends in Fatigue and Fracture NT2F14, „Fatigue and fracture at all scales“*, Belgrade, Serbia, 2014, published in *Structural Integrity and Life*, Vol 14(2) 87-92, 2014;
3. T. Voiconi, L. Marsavina, E. Linul, J. Kováčik, Determination of elastic and damping properties for closed-cell aluminium foams using Impulse Excitation Technique, *Proceedings of XIIIth Youth Symposium of Experimental Solid Mechanics*, 141-145, 2014;
4. E. Linul, D.A. Serban, T. Voiconi, L. Marsavina, T. Sadowski, Energy-absorption and efficiency diagrams of rigid PUR foams, *Key Engineering Materials*, 601, 246-249, 2014 (ISI Proceedings, Scopus);
5. D.A. Apostol, D.M. Constantinescu, L. Marsavina, E. Linul, Analysis of Deformation Bands in Polyurethane Foams, *Key Engineering Materials*, 601, 250-253, 2014 (ISI Proceedings, Scopus);
6. T. Voiconi, E. Linul, L. Marsavina, J. Kovacik, M. Kneć, Experimental determination of mechanical properties of aluminium foams using Digital Image Correlation, *Key Engineering Materials*, 601, 254-257, 2014 (indexat ISI Proceedings, Scopus);
7. T. Voiconi, E. Linul, L. Marsavina, T. Sadowski, M. Kneć, Determination of flexural properties of rigid PUR foams using digital image correlation, *Solid State Phenomena*, 216, 116-121, 2014 (Scopus);
8. L. Marsavina, D.M. Constantinescu, E. Linul, T. Voiconi, D.A. Apostol, T. Sadowski, Evaluation of mixed mode fracture for PUR foams, *Procedia Materials Science*, 3, 1342-1352, 2014 (ScienceDirect)

Book Chapter

- L. Marsavina, D. Constantinescu, *Failure and Damage in Cellular Materials in Failure and Damage Analysis of Advanced Materials*, Eds. H. Altenbach, T. Sadowski, Springer, Udine, 2014.

Applicability and transferability of the results

- Results will be used by foams manufacturers Necumer and Spumotim to improve their technologies. Also, companies using foam components like TRW Automotive and Adidas will benefit by our developed micro-mechanical models to characterize their components and in the product design.

Fields of interest:

- Composite and cellular materials
- Mechanical testing
- Finite Element Analysis
- Fracture and Damage Mechanics

Research team

Prof. Liviu MARȘAVINA, PhD – Project Manager
 Prof. Dan M. CONSTANTINESCU, PhD – Senior Researcher
 Emanoil LINUL, PhD – Postdoc Researcher
 Cristian NES, PhD- Postdoc Researcher
 Dragos A. APOSTOL, PhD – Postdoc Researcher
 Dan A. ȘERBAN, PhD – Postdoc Researcher
 Eng. Tudor VOICONI – PhD student
 Eng. Florin STUPARU – PhD student

“There are no secrets to success. It is the result of preparation, hard work, and learning from failure.”
 Colin Powell

Contact information

Prof. Liviu MARȘAVINA, PhD
 Department Mechanics and Strength of Materials
 Address: Blvd. M. Viteazu, No. 1, R0300222, Timisoara
 Phone: (+40) 256 403 577
 E-mail: liviu.marsavina@upt.ro

MICROSTRUCTURE - MECHANICAL PROPERTIES RELATIONSHIP FOR METALLIC FOAMS BILATERAL AGREEMENT ROMANIA - SLOVAKIA

Goal of the project

Intensification of the already existing, up to date on volunteer basis, international scientific and technological cooperation between Universitatea Politehnica Timisoara (UPT) ROMANIA and Institute of Materials and Machine Mechanics (IMMM) from Slovak Academy of Sciences (SAS) Bratislava, SLOVACIA. This will be achieved by elaboration of common journal papers, and reciprocal sustain of scientific events organised on the partner country, preparation of joint international projects on European basis.

Short description of the project

The technology for foaming of aluminum alloys has been considerably improved in last decade worldwide.

Aluminum foam can undergo static loading, and accidentally dynamic or impact loading during the crash accident. Unfortunately, there is still missing detailed connection between static and dynamic mechanical behaviour of foams.

The project investigates the mechanical properties of metallic foams under dynamic and static loading with respect to foam microstructure.

The project belongs to the priority domain "7 New Materials, Micro and Nanotechnologies – 7.1 Advanced Materials". Cellular metals are a class of advanced materials and investigation on graded cellular metals (cellular structures with different densities in different part of the piece) will also be investigated in present project.

Project implemented by

- Politehnica University of Timisoara
- Institute of Materials and Machine Mechanics (IMMM) from Slovak Academy of Sciences (SAS) Bratislava, SLOVAKIA

Implementation period

01.03.2013 – 10.12. 2014

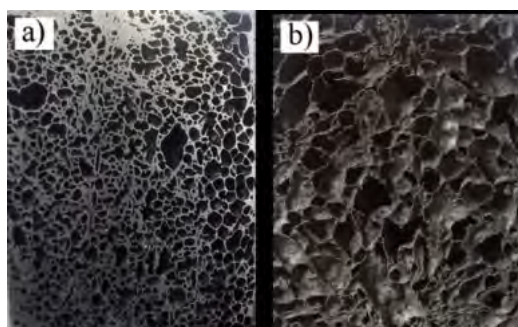

a. AlMg1Si0.6

b. AlSi12Mg0.6

Cellular structures of two aluminium foams

Main activities

- Production of aluminium foams by the Slovak partners.
- Mechanical testing of aluminium foams. The relation between manufacturing parameters, density and mechanical properties was identified.
- Mechanical testing of aluminum foams under dynamic loading. Impact compression tests performed on aluminum foam specimens.
- Investigation of fatigue behavior of aluminium foam.

Main results for 2014 year:

Journal Papers:

1. E. Linul, T. Voiconi, L. Marșavina, J. Kováčik, A comparison between static and dynamic compression behavior of metal foams, (submitted)

Conference Papers:

1. T. Voiconi, E. Linul, L. Marșavina, J. Kováčik, M. Kneć, Experimental determination of mechanical properties of aluminium foams using Digital Image Correlation, Key Engineering Materials, vol. 601, pp. 254-257, 2014, DOI: (ISI Proceedings);
2. J. Kováčik, L. Marsavina, A. Adamčíková, F. Simančík, R. Florek, M. Nosko, P. Tobolka, P. Minár, N. Mináriková, J. Jerz, E. Linul, Uniaxial Compression Tests of Metallic Foams: A Recipe, Key Engineering Materials, vol. 601, pp. 237-241, 2014 (ISI Proceedings);
3. T. Voiconi, L. Marșavina, E. Linul, J. Kováčik, Determination of elastic and damping properties for closed-cell aluminium foams using Impulse Excitation Technique, Proceedings of XIIIth Youth Symposium on Experimental Solid Mechanics, vol. 1, pp. 141-144, 2014, ISBN: 978-80-01-05556-4.

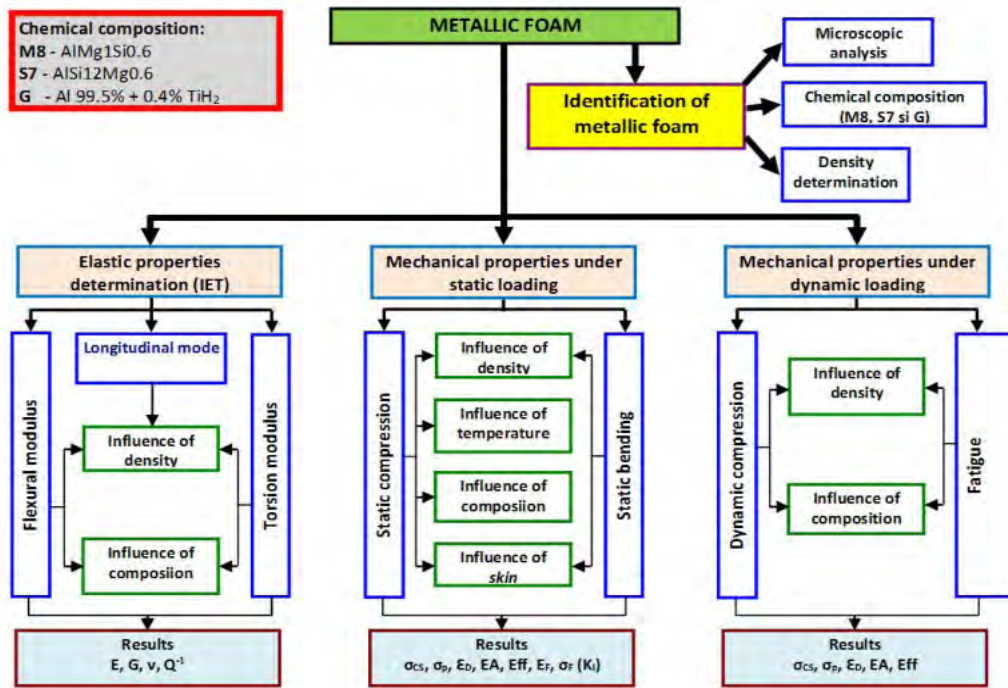

The Experimental plan for characterization of metallic foams

Applicability and transferability of the results

Results could be used by metallic foams manufacturers. Also, companies using foam components from automotive industry will benefit by our results in order to design better foam components as energy absorbers.

Financed through/by

Contract Nr. 653/2013, by Romanian Ministry of National Education, through UEFISCDI

Research team

at Institute of Materials and Machine Mechanics (IMMM) from Slovak Academy of Sciences (SAS) Bratislava, SLOVAKIA

Jaroslav KOVACIK, PhD
 Jaroslav JERZ, PhD
 Roman FLOREK, PhD
 Martin NOSKO, PhD
 Natalia MINARIKOVA, PhD
 Eng. Jana HARNUSKOVA

Research team

at University Politehnica Timișoara, ROMANIA

Prof. Liviu MARȘAVINA, PhD
 Prof. Dr. Eng. Dan M. CONSTANTINESCU, PhD
 Emanoil LINUL, PhD
 Dragos A. APOSTOL, PhD
 Dan A. ȘERBAN, PhD
 Eng. Tudor VOICONI

“There are no secrets to success. It is the result of preparation, hard work, and learning from failure.”

Colin Powell

Contact information

Prof. Liviu MARȘAVINA, PhD
 Department Mechanics and Strength of Materials
 Address: Blvd. M. Viteazu, No. 1, RO300222, Timisoara
 Phone: (+40) 256 403 577
 E-mail: liviu.marsavina@upt.ro

NEW HAPTIC ARM EXOSKELETONS FOR ROBOTICS AND AUTOMATION IN SPACE (EXORAS)

Goal of the project

The project seeks to develop in Romania the capacity to design and manufacture special assemblies meant to work in the field of Robotic Exploration. The overall goal is to stimulate Romania's participation to international space missions and programs, in collaboration with ESA (European Space Agency), as its 19th member. The practical task is to develop a new haptic arm exoskeleton designed to enable in-space force-feedback telemanipulation with redundant robotic arms.

Short description of the project

EXORAS will provide a new haptic arm exoskeleton for robotic exploration. The exoskeleton is desired to explore future ways of commanding a manipulator arm in space. It will be created a prototype with special features of design, namely several shortcomings of previous telemanipulation systems will be removed. The new system pursues requirements regarding weight, ease of wearing and comfort of the human operator. The project assumes the full design, assembling and testing of the prototype. All aspects are taken into account: kinematics, dynamics, sensorics, wireless control, haptic feed-back, actuation, materials and so on.

Project implemented by

- Technical University of Cluj-Napoca – Coordinator
- University "Transilvania" Brasov – Partner 1
- Politehnica University of Timisoara – Partner 2 (146)

Implementation period

2012 – 2015

Main activities

- Research on the development of exoskeleton haptic systems for robotic exploration (existing solutions and development of new solutions; establishment of basic components with functional and technical specifications)
- Concept, design and assembly (mechanical design, kinematic analysis, development of control software, simulation)
- Testing and optimizing of prototypes (assembling, testing and optimizing of prototypes)

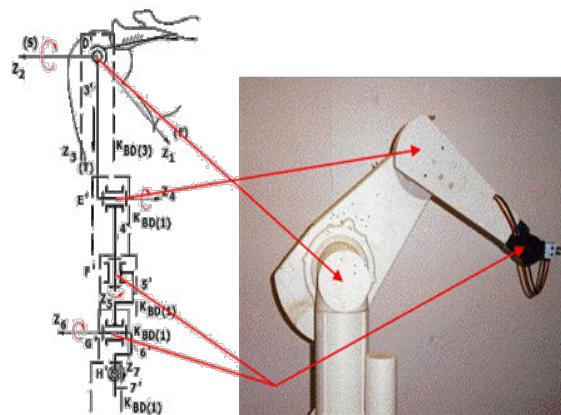

Fig. 1 Corresponding joints of exoskeleton and robot

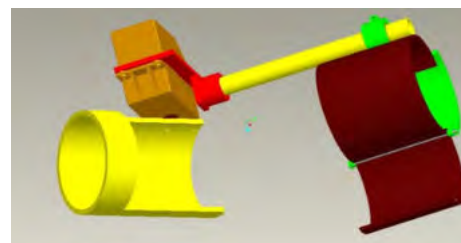

Fig. 2 CAD model of the exoskeleton with servo rotary drive

Results

At this stage, the research work lead to the design and partial implementation of new six solutions of exoskeleton arm. A generic scheme of the general concept from kinematic point of view is given in figure 1.

The design and practical solutions developed until now focused on the elbow and wrist joints. The six variants of exoskeleton under study use:

- servo rotary drive mounted directly on the shaft of the joint (fig. 2)
- linear actuation and transformation of motion (fig. 3)
- free motion and electromagnetic brake (movement transmission via a wire mechanism)
- free motion and electromagnetic brake
- haptic feedback generated by myostimulation
- haptic feedback generated by vibration modules.

The solutions above were judged on a set of criteria and the most convenient alternative proved to be the one using electromagnetic brakes. The CAD model and images of the assembly practically achieved are shown in figure 4.

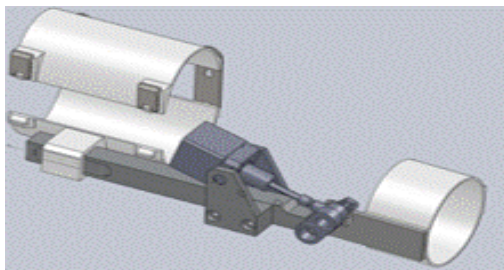

Fig. 3 CAD model of the exoskeleton with linear actuation

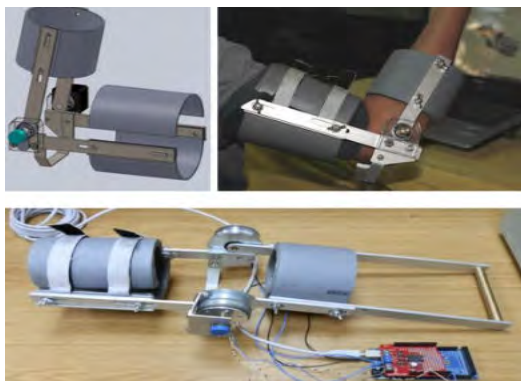

Fig. 4 CAD model and practical assembly of the exoskeleton with free motion and electromagnetic brake

Applicability and transferability of the results

EXORAS fulfills entirely the goal of STAR program (of Romanian Space Agency) that aims increasing of the research competitiveness for participation of academic entities to activities of ESA, included in the law no. 262/2011 regarding the membership status to ESA. This project is going to produce clear benefits to the consortium partners and beyond, regarding the competitiveness of the market for hi-tech mechatronics and robotics. In addition, the gain in knowledge is going to be transferred into higher-education support.

Research centre

Mechatronics&Robotics Research Center

Financed through/by

Funded by the Romanian Space Agency (ROSA) through Contract nr. 13/19.11.2012 within the program STAR 2012 – Projects of RDI, Research direction: S1 Research

Research team

Erwin LOVASZ
Valentin CIUPE
Dan MĂRGINEANU
Corina GRUESCU
Iosif CĂRĂBAŞ
Eugen ZĂBAVĂ
Aurel DIACONU
Inocențiu MANIU
Valer DOLGA
Marius MATEAŞ
Sanda GRIGORESCU
Cristian POP

Contact information

Assoc. Prof. Erwin-Christian LOVASZ, PhD
Department of Mechatronics
Address: Bv. Mihai Viteazu 1, RO300222, Timisoara
Phone: (+40) 256 403 569
E-mail: erwin.lovasz@upt.ro

DOCTORAL AND POSTDOCTORAL SCHOLARSHIPS FOR RESEARCH EXCELLENCE

Goal of the project

The main goal of the project is the strengthening of a competitive framework for the financial support of Ph. D. students and postdoctoral researchers in order to enhance their education. The project provides also a large transnational cooperation between universities, research centres and companies.

Short description of the project

- Facilitation and improvement of the researchers' experience in priority research areas;
- Enhancement the access to research infrastructure in cooperation with universities and renowned research centres in UE;
- Improvement the value of research at both doctoral and postdoctoral level by increasing the number of researchers and the number of priority research topics;
- Providing of funds in support of research activities for twenty Ph.D. students and five postdoctoral researchers of our university;
- Increasing the visibility of research outcome by publishing the results in prestigious journals and conference proceedings.

Project implemented by

- Transilvania University of Brasov
- Politehnica University of Timisoara
- Technical University of Cluj-Napoca
- Universidade Nova de Lisboa (Portugal)
- Université de Technologie de Belfort-Montbéliard (Franta)



Implementation period

15.04.2014 – 14. 10. 2015

Main activities

1. Development of a framework for selecting the target group of researchers to be financed, based on a powerful competition;
2. Financial support for the selected researchers:
 - Monthly stipend of 1800 lei for doctoral students and 3700 lei for postdoctoral researcher,
 - Research fellowship within UE universities of 4200 lei/ month for doctoral researchers,
 - Travel grants for a research stage abroad of 1000 lei,
 - Cover of costs for travel and accommodation in view of participating to scientific events until 1000 lei and 600 lei respectively,
 - Subscriptions/ purchases of scientific publications (2200 lei),
 - Consumables until 2200 lei,
 - Acquisition of a laptop (3000 lei).
3. Tutoring and scientific guidance for researchers;
4. Dissemination of results within seminars and training sessions:

Results

- 25 researchers from UPT were selected (20 Ph.D. students and 5 postdoctoral researchers);
- Financial support for 25 researchers;
- 3 articles published by researchers members of the UPT target group in several international journals;
- 15 published research papers under the signature of the UPT researchers in the proceedings of various international conferences;
- 9 research papers to be published in the proceedings of several international conferences, by UPT researchers.

Applicability and transferability of the results

An up to date management for doctoral and postdoctoral research is a compulsory requirement for any university that aims to be part of the European Research Area.

Doctoral studies are studies of higher education of elite and allow the attainment of qualifications of 8th level, according to the European Qualifications Framework (EQF) and National Qualifications Framework (NQF). Their purpose is to bring a contribution to the development of knowledge through research / innovation / original scientific production and development of dedicated human resources with high level of expertise in scientific research, capable of rapid and efficient insertion on the highly qualified labour market.



Investește în oameni!
FONDUL SOCIAL EUROPEAN
Titlul proiectului: Burse doctorale și postdoctorale pentru cercetare de excelență
Numărul de identificare al contractului: POSDRU/159/1.5/S/134378

DEZVOLTARE DURABILĂ: METODE ȘI MIJLOACE DE ANALIZĂ-EVALUARE-MONITORIZARE A DEZVOLTĂRII SUSTENABILE A SISTEMELOR TEHNICO-ECONOMICE

ETS prof. George Savii

2014



Fields of interest

- Information society technologies
- Energy
- Environment
- Health
- Agriculture
- Materials
- Innovative products and processes
- Socio-economic and humanistic research

Financed through/by

The European Social Fund, Sectoral Operational Programme Human Resources Development – POSDRU

Research team

Prof. Valer DOLGA, PhD
Prof. Arjana DAVIDESCU, PhD
Prof. Anca DRĂGHICI, PhD
Prof. Lacrimioara STOICU-TIVADAR, PhD
Prof. Francisc PETER, PhD
Prof. George SAVII, PhD

Contact information

Prof. Valer DOLGA, PhD
Department of Mechatronics
Address: Bv. Mihai Viteazu, No. 1, RO300222, Timișoara
Phone: (+ 40) 256 403 554 / (+ 40) 256 403 544
E-mail: valer.dolga@upt.ro

DYNAMICAL SYSTEMS AND THEIR APPLICATIONS

Goal of the project

The main objective of this project is to create fundamental knowledge in dynamical systems theory and to apply this knowledge in formulating and analyzing real world models.

Short description of the project

The specific objectives, tasks and methodology of the project are contained in 5 WPs.

- In WP1 we develop new methods for the center and isochronicity problems for analytic and non-analytic systems, study bifurcations of limit cycles and critical periods.
- In WP2 we deal with the problem of integrability for some differential systems with invariant algebraic curves, study global attractors of almost periodic dynamical systems, Levitan/Bohr almost periodic motions of differential/difference equations.
- The main objective of WP3 is to study dynamics of some classes of continuous and discontinuous vector fields.
- WP4 deals with Hamiltonian systems in Plasma Physics, twist and non-twist area preserving maps, numerical methods, and the study of symmetries of certain kinds of k-cosymplectic Hamiltonians.
- The last WP tackles mathematical models in Neuroscience and Medicine.

Project implemented by

1. Politehnica University of Timisoara
2. West University of Timisoara
3. University of Craiova
4. Center for Applied Mathematics and Theoretical Physics, Slovenia
5. University of Maribor, Slovenia
6. Universitat Autònoma de Barcelona
7. Moldova State University
8. The Institute of Mathematics and Computer Science of the Academy of Sciences of Moldova
9. Tiraspol State University

Implementation period

01.10.2012 - 30.09.2016

Main activities

- Develop new methods and algorithms for studying center and isochronicity problems.
- Investigations of reaction-diffusion equations.
- Study of differential and integral operators of non-integer order.
- Study global attractors of almost periodic dynamical systems and their topological structure.
- Study dynamics of certain classes of continuous and discontinuous vector fields.
- Study Hamiltonian systems with $1 \frac{1}{2}$ degrees of freedom and their discrete correspondents, namely systems generated by area-preserving maps.
- Investigations of ODE-based and map-based neuronal models.

Financed through/by

FP7

Results

1. M. Han, Valery G. Romanovski, Limit Cycle Bifurcations from a Nilpotent Focus or Center of Planar Systems, *Abstract and Applied Analysis*, Vol. 2012, Article ID 720830.
2. Valery G. Romanovski, Y. Xia, X. Zhang, Varieties of local integrability of analytic differential systems and their applications, *J. Differential Equations* 257 (2014) 3079–3101.
3. B. Fercec, J. Giné, M. Mencinger, Regilene Oliveira, The center problem for a 1 : -4 resonant quadratic system, *J. Math. Anal. Appl.* 420 (2014) 1568–1591.
4. J. Giné, C. Christopher, M. Presern, Valery G. Romanovski, and N. L. Shcheglova, The Resonant Center Problem for a 2:-3 Resonant Cubic Lotka–Volterra System, V.P. Gerdt et al. (Eds.): *CASC 2012, LNCS 7442*, pp. 129–142, 2012. Springer-Verlag Berlin Heidelberg 2012.
5. Z. Hu, M. Han, V. G. Romanovski, Local integrability of a family of three-dimensional quadratic systems, *Physica D*, Vol. 265 (2013) 78–86.
6. Z. Hu, M. Aldazharova, T. M. Aldibekov, V. G. Romanovski, Integrability of 3-dim polynomial systems with three invariant planes, *Nonlinear Dynamics*, 2013, 74(4), 1077–1092.
7. D. Dolicanin, J. Giné, R. Oliveira, V. G. Romanovski, The center problem for a 2:-3 resonant cubic Lotka–Volterra system. *Applied Mathematics and Computation* Vol. 220 (2013) 12–19.
8. G. Chang, T. Zhang, M. Han, On the number of limit cycles of a class of polynomial systems of Liénard type, *J. Math. Anal. Appl.* 408 (2013) 775–780.
9. C. Liu, M. Han, The Number of Limit Cycles of a Polynomial System on the Plane, *Abstract and Applied Analysis*, Vo. 2013, Article ID 482850.
10. G. Tigan, Analysis of a two-dimensional nonsmooth Poincaré-like map, *Nonlinear Dyn.*, 2014, 75(4), 643–651.
11. M. Racila, Recent Researches in Medicine, Biology and Bioscience, pp. 39–44, 2013.
12. Corina N. Babalic, Radu Constantinescu and Vladimir S. Gerdjikov, Two soliton solutions of Tzitzeica equation, *Physics AUC*, vol 23, 36–41, 2013.
13. Corina N. Babalic, Adrian S. Carstea, On some new forms of lattice integrable equations, *Central European Journal of Physics*, 12(5), 341–347, 2014.

Research team

- G. TIGAN
- C. LAZUREANU
- T. BINZAR
- M. STELIAN
- D. CONSTANTINESCU
- R. CONSTANTINESCU
- R. MILITARU
- F. MUNTEANU
- M. RACILA
- J. LLIBRE
- N. VULPE
- D. CHEBAN
- A. SUBA
- V. ROMANOVSKI
- D. PAGON
- D. COZMA
- V. GROMAK
- A.P. SADOVSKII
- V.V. AMELKIN
- M. HAN
- X. ZHANG
- W. ZHANG
- R. OLIVEIRA
- M. LIMA
- J. CASSIANO

Contact information

Lect. Gheorghe ȚIGAN, PhD
 Department of Mathematics
 Address: P-ta Victoriei, No. 2, RO300006, Timisoara
 E-mail: gheorghe.tigan@upt.ro

RANDOM MATRIX TECHNIQUES IN QUANTUM INFORMATION THEORY (RMTQIT)

Goal of the project

The field of Quantum Information Theory (QIT) attracted lately the interest of scientific community due to its ambitious goals meant to create new technologic systems (quantum computers) and new more secured methods to transmit the information. Nowadays, QIT is a multi-faceted field, with large connections in the subfields of Mathematics, such as Functional Analysis, Operator Theory, Linear Algebra, Probability Theory. The project RMTQIT purposes to give answers to open questions from QIT, using techniques from random matrix theory.

Short description of the project

The project RMTQIT focuses on a systematic exploration of theoretical questions in QIT about random quantum states and random quantum channels. These problems have attracted the attention lately in a very naturally connection to fundamental issues of QIT theory, such as entanglement theory and classical (or quantum) capacities for channels.

Project implemented by

1. The Department of Mathematics, Politehnica University of Timișoara.
2. Laboratoire de Physique Théorique de Toulouse, Université Paul Sabatier Toulouse III, France.

Implementation period

01.03.2013 - 29.02.2016

Main activities

In the last year within the project RMTQIT it took place interesting activities meant to complete the scientific tasks purposed as well as to extend and attract new collaborators.

- First of all, it would like to mention that we welcomed at Timișoara for short visits some of our collaborators: Dr Ion Nechita, Dr. David Reeb, from Zentrum Mathematik, Technische Universität München, Dr. Kim Dang, from Department of Mathematics Yale University and Prof. Dr. Antonino Messina, from University Palermo, Italy.
- Dr. David Reeb presented the research seminar "Extending Quantum Channels", on 16 July 2014 at Department of Mathematics, UPT.
- The results of our research activity were presented to scientific community with several occasions:
- in May at University of Munchen, where dr M.A. Jivulescu presented the talk "On the reduction criterion for random quantum states", at the 25th edition of the Conference on Operator Theory, Timișoara, where dr. Nicolae Lupa presented the talk "Eigenvalue distribution of the reduced Wishart matrices and applications in quantum information theory".

Results

1. Maria Anastasia Jivulescu, Nicolae Lupa, Ion Nechita - On the reduction criterion for random quantum states - JOURNAL OF MATHEMATICAL PHYSICS, Volume: 55, Issue: 11, Article Number: 112203-1-27, NOV 2014, (arXiv:1402.4292)
2. António J. G. Bento, Nicolae Lupa, Mihail Megan, César M. Silva - Integral conditions for nonuniform μ -dichotomy - arXiv:1405.2946
3. Maria Anastasia Jivulescu, Nicolae Lupa, Ion Nechita, David Reeb - Positive reduction from spectra - LINEAR ALGEBRA and its APPLICATIONS, Volume 469, NOV 2014, Pag. 276-304, doi:10.1016/j.laa.2014.11.031 (arXiv:1406.1277)
4. Motohisa Fukuda, Ion Nechita, Michael M. Wolf - Quantum channels with polytopic images and image additivity - arXiv:1408.2340
5. Motohisa Fukuda, Ion Nechita - Additivity rates and PPT property for random quantum channels - arXiv:1411.6881
6. M.R. Abdollahpour, A. Najati, P. Gavrută - Multipliers of pg-Bessel sequences in Banach spaces - arXiv:1501.01146v1

Financed through/by

- UEFISCDI, Romania
- L'Agence Nationale de la Recherche (ANR), France

Research Team

- Assist. Prof. Maria Anastasia JIVULESCU
- Dr. Ion NECHITA
- Prof. Găvrută PAȘC
- Assist. Dr. Nicolae LUPA

Contact information

Assist. Prof. Maria Anastasia JIVULESCU
 Department of Mathematics
 Address: Victoriei Square, no 2, RO300006, Timișoara
 Phone: (+40) 256 403 098
 Fax: (+40) 256 403 109
 Mobile: (+40) 740 517 340
 E-mail: maria.jivulescu@upt.ro
 Web: <https://sites.google.com/site/rmtqit2013/>

KNOWLEDGE MANAGEMENT-BASED RESEARCH CONCERNING INDUSTRY-UNIVERSITY COLLABORATION IN AN OPEN INNOVATION CONTEXT- UNIINOI

Goal of the project

In the present competitive climate, research knowledge and innovation are seen as the main distinguishing factors of firm success and as the basis of competitive advantages. Following a long tradition of research in the field of innovation, Open Innovation is an approach in which the boundaries of innovation are shifting from a situation where firms conduct research and development activities mainly internally, to a widespread collaboration and external knowledge source, to help them in achieving and sustain innovation. Although universities are seen among the most important partners with whom firms can cooperate, quantitative empirical evidence with regards to the development, evolution and sustainability of Industry-University relations in Open Innovation is still very scarce.

Main activities

- The general objective of the project is to sustain the research and development activities, based on knowledge management and carried out in collaboration by the consortium partners, for the development of an environment that promote Industry-University collaboration in Open Innovation.

Project implemented by

- University of Oradea
- Politehnica University of Timisoara
- Technical University of Cluj-Napoca
- S.C. EMSIL TECHTRANS S.R.L.

Implementation period

2014-2016

Main activities

1. The development of the collaborative research environment
2. The development of an Open Innovation environment between Industry-University
3. The development of a model for performance measurement of Industry-University collaboration in Open Innovation

Financed through/by

Ministry of National Education
The Executive Unit for Financing Higher Education, Research, Development and Innovation
Programme Partnerships in Priority Domains - Contract 337/2014
The Executive Unit for Financing Higher Education, Research, Development and Innovation (UEFISCDI)
Total budget of the contract: 1.062.479 lei
Public budget: 923.729 lei
Own budget: 138.750 lei

Research Team

- Anca DRAGHICI
- Larisa IVAȘCU
- Călin Florin BĂBAN
- Laura BACALI
- Silviu Dan MÎNZAT

Contact information

Prof. Anca Draghici, PhD
Department of Management
Adress: Str. Remus, No. 14, RO 300191, Timisoara,
Tel.: (+40) 256 404 037; (+40) 256 403 061
E-mail: anca.draghici@upt.ro

Projects supporting research

Field	Total number of projects	Source of financing	Number of projects
Automation and Computers	2	Cross-border cooperation HU-RO* Cross-border Cooperation RO-SR*	1 1
Engineering and Management	1	International Program**	1
Industrial Engineering	1	POSDRU*	1

* *Structural Funds - European Regional Development Fund, European Social Fund and the Romanian National Authority for Scientific Research,*

** *International Program - Leonardo da Vinci, Transfer of Innovation project (LDV-TOI)*

LEADSUS LEADERSHIP IN SUSTAINABILITY – SUSTAINABILITY MANAGER

Goal of the project

The general objective is to transfer and integrate a new skill at the level of European industry and institutions. Specific objectives of the LeadSUS project are:

1. Adaptation, harmonization and refinement of existing training materials and their integration into a professional training program dedicated to employees of companies, institutions and VET organizations;
2. Achievement of EU Certification of the new training program and job role as Sustainability Manager within the ECQA framework;
3. Creation of E-learning platform within the ECQA to facilitate the on-line training on sustainability management for different trainees from different EU locations;
4. Extension of Capability Adviser - Process Management Software Tool to support Sustainability Management assessment methodology;
5. Testing/piloting the training program in Romania and France;
6. Building the capacity in Sustainability Management topics in Romania, Slovenia and France by training of future trainers (15 persons) and future Sustainability Managers (110 persons).

Short description of the project

Activities and details about the LeadSUS project are available on the project web page: www.leadsus.eu

The project activities and results will support organizational leaders and employees, to understand the strategic implications of sustainability by developing innovative and creative approaches.

LeadSUS training program will drive leadership understanding, strategic business approaches, enthusiasm, innovation and consideration of environment and social aspects as key issues toward sustainable development. The training program is developed by the project consortium members and it will be available on-line as multimedia training materials with exercises, case studies and references (in English and Romanian languages), but also, in a printed book that will be a guide for sustainable managers.

LeadSUS training program develops competences and skills on the following topics:

- Sustainability management,
- Economic sustainability,
- Ecologic sustainability,
- Social sustainability,
- Product sustainability.

LeadSUS training program is developed in accordance with the ECQA (European Certification and Qualification Association) guidelines (www.ecqa.org). All participating trainees will have the opportunity to certify their newly acquired skills and competences within ECQA framework, on two performance levels: foundation or advanced.

LeadSUS training and certification platform will be available on www.ecqa.org

The project target group consists of managers and employees, representatives of private organizations (industry related) and public organizations, with environmental, social or business development related responsibilities and employed master students.

Project implemented by



DSRO – SC DENKSTATT ROMANIA SRL,
Timisoara, Romania www.denkstatt.ro



UPT – Politehnica University of Timisoara,
Romania www.upt.ro



INPG - Institut Polytechnique de Grenoble,
France www.grenoble-inpg.fr



BICERO - BICERO, Business Informatics Center
Rozman Ltd., Slovenia www.bicero.com



EMIRacle – European Manufacturing and
Innovation Research Association, Brussels,
Belgium (www.emiracle.eu)



ISCN – International Software Consulting
Network I.S.C.N. GesmbH, Graz, Austria www.iscn.com

Implementation period

18.11.2013 – 18.11.2015



Main activities

LeadSUS project activities are described by the following work packages (WP):

WP 1 - Project management

- 1.1. Project coordination and collaboration
- 1.2. Project Administration and reporting

WP2 - Project Quality management

- 2.1. Project quality and evaluation criteria
- 2.2. Configuration management and Project Document Control
- 2.3. Quality reviews

WP3 - Identification of market needs and skill set design

- 3.1. Identification of target group and their needs
- 3.2. Identification of innovative methods, tools standards and techniques to satisfy the target group needs
- 3.3. Identification of similar training programs
- 3.4. Certified Sustainability Manager Skills set design

WP4 - LeadSUS - Sustainable Manager training material package adaptation and refinement

- 4.1. Adaptation and refinement of existing training materials and adapting to the skill set and material translation into EN, SI, FR and RO languages
- 4.2. Multimedia materials
- 4.3. Development and extension of Process management tool with Sustainability section
- 4.4. Development of Leadership in Sustainability Guide

WP5 - ECQA E learning platform configuration

- 5.1. Prepare and configure the On line learning management system and self assessment portal
- 5.2. Prepare On line course based on the training material

WP6 - Examination and Certification within ECQA framework

- 6.1. ECQA Exam Question Database
- 6.2. Certified Sustainability Manager Job role Committee

WP7 - Dissemination and exploitations of results

- 7.1. Dissemination and exploitation plan, micro planning
- 7.2. Dissemination activities and records
- 7.3. Final event of the project
- 7.4. Leadership in Sustainability Guide publishing and distribution

WP8 - Transfer of knowledge to Slovenia, France and Romania

- 8.1. Pilot training in Grenoble
- 8.2. Pilot training in Timisoara
- 8.3. Train the trainers in Timisoara
- 8.4. Train the trainers in France
- 8.5. LeadSUS - Sustainability Manager training for company and institutions trainees in Timisoara/Romania
- 8.6. LeadSUS - Sustainability Manager training for company and institutions trainees in Bucharest/Romania
- 8.7. LeadSUS - Sustainability Manager training for company and institutions trainees in France
- 8.8. LeadSUS - Sustainability Manager training for company and institutions trainees in Slovenia

Results

The main result of the LeadSUS project will be a complete defined training and certification program called: Leadership in sustainability – Sustainability Manager. The training materials (in English, Romanian, French and Slovenian languages) will be available on-line on a designed web platform (ECQA e-learning platform) and the certification program will be supported by the European Certification and Qualification Association (www.ecqa.org).

Applicability and transferability of the results

The consortium's vision is to create a great impact in Romanian, Slovenian and French companies and in-stitutions. One Sustainability Manager can shift an entire company in the direction of sustainable development. Leading Sustainability is a key issue in companies and institutions. One professional Trainer in Sustainability Management will impact companies and institutions on a long term, providing capacity building for future Sustainability Managers.

LearSUS project will have impact in 3 countries (Romania, Slovenia, France) and 4 related regions (Western and Bucharest-Ilfov Regions in Romania, North-Eastern Slovenia, South – Eastern France).

LeadSUS training program will be transfer and assimilated with a master or post-graduate program developed by UPT. In additional, project pool knowledge will be transfer in some PhD and post-doctoral research programs.

There is planned a long term impact of the LeadSUS project in the EU wide, by creation of a new ECQA Certified Job Role (www.ecqa.org) in a new profession, available for EU citizens and more.

Financed through/by

European Commission, Educational, Audiovisual & Culture Executive Agency

LIFELONG LEARNING PROGRAMME, through the National Agency in Romania (www.anpcdefp.ro)

A Leonardo da Vinci, Transfer of Innovation project (LDV-TOI)

Research team

Prof. Anca DRAGHICI, PhD; Prof. Gabriela PROSTEAN, PhD; Prof. George DRAGHICI, PhD; Prof. George Gustav SAVII, PhD; Prof. Georgeta CIOBANU, PhD; Assist. Prof. Sorin SUCIU, Assist. Prof. Claudiu ALBULESCU, Assist. prof. Caius LUMINOSU

Contact information

Prof. Anca DRAGHICI, PhD

Department of Management

Address: Remus Str., No. 14, 3R000191, Timisoara

Phone: (+40) 256 403 610

E-mail: anca.draghici@upt.ro

Web: <http://leadsus.bicero.com/>

ACTIVE INSERTION ON THE LABOR MARKET THROUGH INNOVATIVE TRAINING IN ENGINEERING – FORMING

Goal of the project

The project's goal is the employability improving for the unemployed and people looking for a job, by providing integrated services and innovative counseling, mediation and customized engineering training in order to improve skills and professional competencies and a greater correlation of them with the labor market needs in the North-East, West, Central, South-Muntenia and Bucharest-Ilfov Regions.

Short description of the project

- The project addresses to graduate people of secondary and higher technical education studies that fits into one of the following categories: unemployed, long-term unemployed, people searching for a job (never been employed) or inactive people.

Project implemented by

- Politehnica University of Bucharest
- Politehnica University of Timisoara
- "Lucian Blaga" University of Sibiu
- Technical University "Gheorghe Asachi" of Iași
- The Red Point SA
- S.C. Ascendo S.R.L.

Implementation period

01.04.2014 – 30.09.2015

Main activities

- A1. Project Management
- A2. Information, communication and advertising activities develop to support the attending of project objectives and indicators
- A3. Providing information and professional counseling services for individuals and groups of people (included in the target group)
- A4. Providing mediation services, including individual mediation plans development and job shops organization

- A5. Providing training programs (through techniques and modern methods using a ICT) and professional development
- A5.1. Developing, implementing and maintaining the ICT platform that will integrate applications required in the project
- A5.2. Designing and developing of the on-line and onsite courses (training support) as well as providing professional training services

Results

The expected results/indicators at the national level are:

1. 1000 people informed and beneficiaries of the professional orientation services
2. 400 people, beneficiaries of the mediation services
3. 960 persons selected for being participants in the professional training program (courses)
4. Minimum 100 information actions on project activities
5. Organization of 4 job shops
6. 288 long time unemployed people participants in integrated programs, out of which: 136 women, 74 young people, and 78 people having more than 45 years old
7. 61% of the integrated programs participants should be certified
8. 13% of the integrated programs participants should be employed in the next six months (from the end of the project)



Applicability and transferability of the results

Long-term positive effects of the project are:

- Human capital development in accordance with the requirements of a highly competitive labor market in the engineering field;
- Fostering integration and reintegration into the labor market of the unemployed with secondary or higher technical education, from rural and urban areas by providing individualized training programs and in accordance with market requirements. These will contribute to the increasing of the employment rate.
- Stimulation of the (re)integration into the labor market of the people from the regional target groups by providing them real opportunities on finding and getting a job in the field of engineering; these will contribute to the employment rate increasing on the labor market, in accordance with vision of the general objective of the Programme.



Research centre

- Integrated Engineering Research Center (CCII)
- Materials and Manufacturing Engineering Department (IMF)



Financed through/by

EUROPEAN SOCIAL FUND

Sectoral Operational Programme Human Resources Development
2007 – 2013

Priority: 5. Promoting active employment measures

Key Area of Intervention: 5.1. Developing and implementing active
employment measures

Cod Contract: POSDRU/125/5.1/S/134003

Research team

Prof. George-Emilian DRĂGHICI, PhD – Leader

Assoc. Prof. Cristian-Gheorghe TURC, PhD – Leader Assistant

Assoc. Prof. Eugen PĂMÎNȚĂȘ, PhD – Technical coordinator

Assoc. Prof. Mircea NICOARĂ, PhD – Training coordinator

Lecturer Felicia Veronica BANCIU, PhD – Expert responsible with the
target group

Lecturer Adrian BUT, PhD – Expert responsible with the labor market
relation

Silvia Ana JURCHESCU – Financial expert

Dana SUBA – Legal and acquisitions expert

Andrea Valeria MARIN – Accountant

Contact information

Prof. George DRĂGHICI, PhD

Department of Materials and Manufacturing Engineering

Address: Bv. Mihai Viteazu, No.1, RO300222, Timisoara

Phone: (+40) 256 403 610

Mobile: (+40) 740 348 430

E-mail: george.draghici@upt.ro

Web: http://www.eng.upt.ro/imf/ccii/index_en.html

CROSS-BORDER ACCESS INFRASTRUCTURE TO HIGH-LEVEL EDUCATION THROUGH WEB-CASTS

Goal of the project

The overall goal of the project is to increase the overall competitiveness of the economy in the border area by creating a cross-border partnership between the Faculty of Automation and Computers from Timisoara and the Technical Faculty from Zrenjanin and by improving the quality of education for the students and pupils from the border area.

Short description of the project

The aim of this partnership is to implement an infrastructure for live and on-demand video streaming of learning material for the target groups and to this purpose establish a long and fruitful cooperation between teachers, pupils and students on both sides of the border. The infrastructure is presented below:

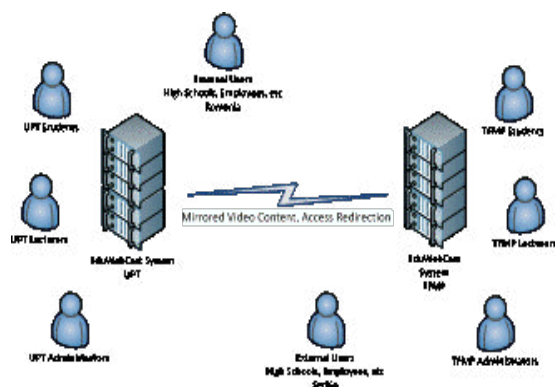

The joint realization and administration of the web cast project is the result of the partnership between the two faculties and will lead to more common projects based on the materials created through the project, contests between pupils and students, possible periodic educational exchanges. Besides the students, the academic personnel will have the chance to contact their homologues on the other side of the border and exchange opinions, information and teaching techniques which will help improve the entire educational process in both partners to the benefit of the target groups.

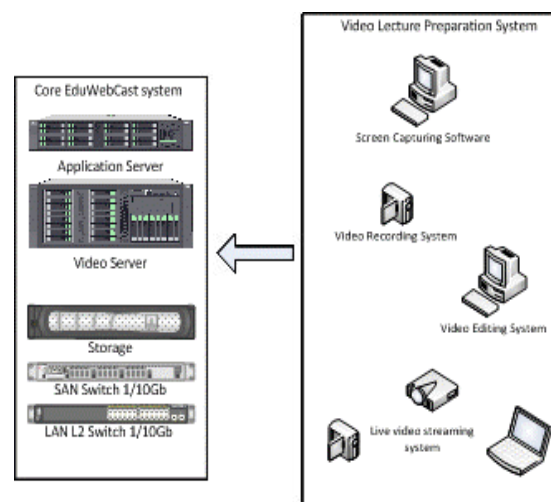

Project implemented by

- Politehnica University of Timișoara, UPT – Lead partner
- Technical Faculty “Mihajlo Pupin” Zrenjanin – Project partner

Implementation period

19.12.2013 – 18.06.2015

Main activities:

1. Communication and publicity activities;
2. Establishment of the hardware and software architecture;
3. Establishment of the content of the lectures;
4. Acquisition of the specific equipments and software.

Results

1. Several technical meetings took place both in Timișoara and Zrenjanin. As a consequence the architecture of the system was established both in the hardware and software parts.
2. The specifications were studied and both teams agreed on a list of equipments and on the features of the software.
3. The number of the lectures and their content were established.
4. The acquisition processes were launched.

Fields of interest:

Live and on-demand video

Applicability and transferability of the results:

- Achievement of a secure WiFi network covering a large area, offering also the EDUROAM service and IP streaming service
- Possibility to develop research oriented on IP streaming, network traffic and main features.

Research centre

Research Center in Computers and Information

Financed through/by

Romania–Republic of Serbia IPA Cross-Border Cooperation Programme

Research team

Mircea POPA
Cristian VAȘAR
Octavian PROȘTEAN
Marius MARCU
Sebastian FUICU
Răzvan BOGDAN
Anca Sorana POPA
Versavia ANCUȘA
Marinela BĂLUȚ

Contact information

Prof. Mircea POPA, PhD
Department of Computers
Adress: Blv. V. Pârvan, No. 2, R0300223 Timișoara
Phone: (+40) 256 403 003
Fax: (+40) 256 403 023
Email: mircea.popa@upt.ro

JOINT CROSS-BORDER INTERNET COMMUNICATION SYSTEM OF THE UNIVERSITY OF DEBRECEN AND POLITEHNICA UNIVERSITY OF TIMISOARA

Goal of the project

The overall goal of the project is to enable enhanced capacity for cross-country cooperation and interaction between and within the participating universities by providing high quality WiFi system and IP streaming system for the students, professors and researchers at the University of Debrecen and Politehnica University of Timisoara, aiming at supporting the synchronization of educational, research and development, and other scientific activities of the cooperating universities.

Short description of the project

- Interior and exterior WiFi service will be installed at both sites to be able to access from mobile notebooks and smart phones the partners data and services infrastructure and Internet services.
- The project implements the EDUROAM service in PUT. This common authentication service with other universities within Europe allows accessing WiFi Internet, increases the Internet accessibility for both academic partners and incoming students travelling to PUT and UD.
- IP streaming subsystem will be installed at both universities to be able to interchange the local multimedia content between the partners.

Project implemented by

- University of Debrecen, UD – Lead partner
- Politehnica University of Timișoara, UPT – Project partner

Main activities

- Communication and publicity activities;
- Acquisition of the specific equipments;
- Development and implementation of the specific WiFi network;
- Development and implementation of the specific IP streaming system.

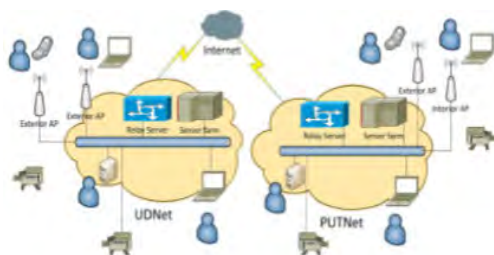

Implementation period

01.01.2013 – 31.05.2014

Results

- Several technical meetings took place both in Timișoara and Debrecen. As a consequence the inherently implementation problems were discussed and solved.
- The placement of the 200 Access Points covering the interior and exterior of the buildings of the faculties and student hostels from the campus was achieved and the connection to the specific infrastructure was done.
- The specific infrastructures for implementing the EDUROAM service and the IP streaming video service were developed and implemented.
- Tests were done and also the dissemination of the results was done.
- A closing event was organized.

Fields of interest:

- WiFi networks, IP streaming

Applicability and transferability of the results:

- Achievement of a secure WiFi network covering a large area, offering also the EDUROAM service and IP streaming service.
- Possibility to develop research oriented on IP streaming, network traffic and main features.

Research centre

- Research Center in Computers and Information

Financed through/by

- Hungary-Romania Cross-Border Co-operation Programme 2007-2013

Research team

Mircea POPA, Marius MARCU, Sebastian FUICU, Răzvan BOGDAN, Oana AMARICĂI-BONCALO, Sorin JULEAN, Marian SALAVAT, Mihaela CIULEAN, Marinela BĂLUȚ

Contact information

Prof. Mircea POPA, PhD
Department of Computers
Adress: Blv. V. Pârvan, No. 2, RO300223 Timișoara
Phone: (+40) 256 403 003
Fax: (+40) 256 403 023
Email: mircea.popa@upt.ro

Projects supported by private funds

Field	Total number of projects	Number of projects presented
Automation and Computers	8	-
Electrical and Power Engineering	11	8
Electronics and Telecommunications Engineering	5	-
Chemical Engineering	13	2
Civil Engineering	31	4
Mechanical Engineering	61	5
Engineering and Management	3	-
Mathematics	1	1
Learning	1	-

PHOTOVOLTAIC SOURCES INTEGRATION IN THE ROMANIAN POWER SYSTEM. CASE STUDY FOR TIMIS AREA

Goal of the project

Power system analysis and optimization for the photovoltaic sources integration in the Timis area of the Romanian Power System (Enel Banat Distribution Operator).

Short description of the project

The renewable energy sources represent an important issue for the Romanian and EU energy policy and sustainable development strategy. The projects refer to photovoltaic sources integration in the Timis area of the Romanian Power System (Enel Banat Distribution Operator). The analysis has been performed for the North-Western, Western, Central and South-Western part of the System. Various operating condition, with the consumption forecast for 2014, 2018 and 2023, were considered, taking into account all the renewable energy sources (wind, solar, biomass, hydro). The medium voltage network for the interest area was modelled in detail.

Project implemented by

- Enel Distribuție Banat
- GML Bio Energy
- Efficient Solar
- Pro Dance Show Timisoara

Implementation period

2014-2015

Main activities

- power system data base validation;
- Enel Banat distribution network modeling and operating condition analysis;
- power consumption and renewable energy generation forecast;
- power flow computing for various operating condition of the North-Western, Western, Central and South-Western part of the Romanian Power System (peak and minimum type regimes, 2013, 2018, 2023);
- contingency analysis, in the presence / absence of the renewable energy sources.



Results

- power flow corresponding to 2013 year and forecasted 2018 and 2023 years;
- power flow corresponding to the medium voltage electrical network (Enel Banat Timisoara area);
- voltage value without / with the new producers;
- quick / slow maximum voltage variation value for critical buses;
- transformer loading without / with the new producers;
- power flow through the power system elements and loading level;
- integration solution validation and system reinforcement recommendations (if necessary).

Applicability and transferability of the results

Knowledge transfer to other photovoltaic power plants developers and designers. Electrical distribution network operator (Enel, CEZ, EON, Electrica in Romania).

Fields of interest

- photovoltaic energy sources;
- other renewable energy sources;
- renewable sources' integration in the power systems;
- distribution network operators.

Research Centre

Research Centre for Power Systems Analysis and Optimization

Financed through/by

GML Bio Energy, Efficient Solar, Pro Dance Show Timisoara, total value: 18.786 RON (4.175 Euro)

Research team

Stefan KILYENI, Constantin BARBULESCU, Attila SIMO, Annamaria KILYENI

Contact information

Prof. Ștefan KILYENI, PhD
Department of Power Engineering
Address: Bd. Vasile Pârvan, No. 2, RO300223, Timisoara
Phone: (+40) 256 403 430
Mobile: (+40) 745 180 818
E-mail: stefan.kilyeni@upt.ro
Web: www.et.upt.ro

PHOTOVOLTAIC SOURCES INTEGRATION IN THE ROMANIAN POWER SYSTEM. CASE STUDY FOR TIMISOARA AREA

Goal of the project

Power system analysis and optimization for the photovoltaic sources integration in the Timisoara area of the Romanian Power System (Enel Banat Distribution Operator).

Short description of the project

The renewable energy sources represent an important issue for the Romanian and EU energy policy and sustainable development strategy. The projects refer to photovoltaic sources integration in the Timisoara area of the Romanian Power System (Enel Banat Distribution Operator). The analysis has been performed for the North-Western, Western, Central and South-Western part of the System. Various operating condition, with the consumption forecast for 2014, 2018 and 2023, were considered, taking into account all the renewable energy sources (wind, solar, biomass, hydro). The medium voltage network for the interest area was modelled in detail.

Project implemented by

- Enel Distributie Banat
- AHM Smartel
- Ambra Service Timisoara

Implementation period

2014-2015

Main activities

- power system data base validation;
- Enel Banat distribution network modelling and operating condition analysis;
- power consumption and renewable energy generation forecast;
- power flow computing for various operating condition of the North-Western, Western, Central and South-Western part of the Romanian Power System (peak and minimum type operating conditions, 2014, 2018, 2023);
- contingency analysis, in the presence / absence of the renewable energy sources.



Results

- power flow corresponding to 2014 year and forecasted 2018 and 2023 years;
- power flow corresponding to the medium voltage electrical network (Enel Banat Timisoara area);
- voltage value without / with the new producers;
- quick / slow maximum voltage variation value for critical buses;
- transformer loading without / with the new producers;
- power flow through the power system elements and loading level;
- integration solution validation and system reinforcement recommendations (if necessary).

Applicability and transferability of the results

Knowledge transfer to other photovoltaic power plants developers and designers. Electrical distribution network operator (Enel, CEZ, EON, Electrica in Romania).

Fields of interest

- photovoltaic energy sources;
- other renewable energy sources;
- renewable sources' integration in the power systems;
- distribution network operators.

Research Centre

Research Centre for Power Systems Analysis and Optimization

Financed through/by

AHM Smartel, Ambra Service Timisoara, total value: 18.848 RON (4.100 Euro)

Research team

Stefan KILYENI, Constantin BARBULESCU, Attila SIMO, Annamaria KILYENI

Contact information

Prof. Ștefan KILYENI, PhD
Department of Power Engineering
Address: Bd. Vasile Pârvan, No. 2, RO300223, Timisoara
Phone: (+40) 256 403 430
Mobile: (+40) 745 180 818
E-mail: stefan.kilyeni@upt.ro
Web: www.et.upt.ro

PHOTOVOLTAIC SOURCES INTEGRATION IN THE ROMANIAN POWER SYSTEM. CASE STUDY FOR LUGOJ AREA

Goal of the project

Power system analysis and optimization for the photovoltaic sources integration in the Lugoj area of the Romanian Power System (Enel Banat Distribution Operator).

Short description of the project

The renewable energy sources represent an important issue for the Romanian and EU energy policy and sustainable development strategy. The projects refer to photovoltaic sources integration in the Lugoj area of the Romanian Power System (Enel Banat Distribution Operator). The analysis has been performed for the North-Western, Western, Central and South-Western part of the System. Various operating condition, with the consumption forecast for 2014, 2018 and 2023, were considered, taking into account all the renewable energy sources (wind, solar, biomass, hydro). The medium voltage network for the interest area was modelled in detail.

Project implemented by

- Enel Distribuție Banat
- AroTenPower
- AroNinePower
- Aro11Power Timisoara

Implementation period

2014–2015

Main activities

- power system data base validation;
- Enel Banat distribution network modeling and operating condition analysis;
- power consumption and renewable energy generation forecast;
- power flow computing for various operating condition of the North-Western, Western, Central and South-Western part of the Romanian Power System (peak and minimum type regimes, 2013, 2018, 2023);
- contingency analysis, in the presence / absence of the renewable energy sources.



Results

- power flow corresponding to 2013 year and forecasted 2018 and 2023 years;
- power flow corresponding to the medium voltage electrical network (Enel Banat Timisoara area);
- voltage value without / with the new producers;
- quick / slow maximum voltage variation value for critical buses;
- transformer loading without / with the new producers;
- power flow through the power system elements and loading level;
- integration solution validation and system reinforcement recommendations (if necessary).

Applicability and transferability of the results

Knowledge transfer to other photovoltaic power plants developers and designers. Electrical distribution network operator (Enel, CEZ, EON, Electrica in Romania).

Fields of interest

- photovoltaic energy sources;
- other renewable energy sources;
- renewable sources' integration in the power systems;
- distribution network operators.

Research Centre

Research Centre for Power Systems Analysis and Optimization

Financed through/by

AroTenPower, AroNinePower, Aro11Power Timisoara, total value: 18.228 RON (4050 Euro)

Research team

Stefan KILYENI, Constantin BARBULESCU, Attila SIMO, Annamaria KILYENI

Contact information

Prof. Ștefan KILYENI, PhD
Department of Power Engineering
Address: Bd. Vasile Pârvan, No. 2, RO300223, Timisoara
Phone: (+40) 256 403 430
Mobile: (+40) 745 180 818
E-mail: stefan.kilyeni@upt.ro
Web: www.et.upt.ro

MICRO-HYDRO POWER PLANTS INTEGRATION IN THE ROMANIAN POWER SYSTEM. CASE STUDY FOR CARAS-SEVERIN AREA

Goal of the project

Power system analysis and optimization for the micro-hydro power plants integration in the Caras-Severin area of the Romanian Power System (Enel Banat Distribution Operator).

Short description of the project

The renewable energy sources represent an important issue for the Romanian and EU energy policy and sustainable development strategy. The projects refer to micro-hydro power plants integration in the Caras-Severin area of the Romanian Power System (Enel Banat Distribution Operator). The analysis has been performed for the North-Western, Western, Central and South-Western part of the System. Various operating condition, with the consumption forecast for 2014, 2018 and 2023, were considered, taking into account all the renewable energy sources (wind, solar, biomass, hydro). The medium voltage network for the interest area was modelled in detail.

Project implemented by

- Enel Distribuție Banat
- Termoforest Toplet

Implementation period

2014-2015

Main activities

- power system data base validation;
- Enel Banat distribution network modeling and operating condition analysis;
- power consumption and renewable energy generation forecast;
- power flow computing for various operating condition of the North-Western, Western, Central and South-Western part of the Romanian Power System (peak and minimum type operating conditions, 2014, 2018, 2023);
- contingency analysis, in the presence / absence of the renewable energy sources.



Results

- power flow corresponding to 2013 year and forecasted 2018 and 2023 years;
- power flow corresponding to the medium voltage electrical network (Enel Banat Timisoara area);
- voltage value without / with the new producers;
- quick / slow maximum voltage variation value for critical buses;
- transformer loading without / with the new producers;
- power flow through the power system elements and loading level;
- integration solution validation and system reinforcement recommendations (if necessary).

Applicability and transferability of the results

Knowledge transfer to other photovoltaic power plants developers and designers. Electrical distribution network operator (Enel, CEZ, EON, Electrica in Romania).

Fields of interest

- photovoltaic energy sources;
- other renewable energy sources;
- renewable sources' integration in the power systems;
- distribution network operators.

Research Centre

Research Centre for Power Systems Analysis and Optimization

Financed through/by

Termoforest Toplet, total value: 9.300 RON

Research team

Stefan KILYENI, Constantin BARBULESCU, Attila SIMO, Annamaria KILYENI

Contact information

Prof. Ștefan KILYENI, PhD
Department of Power Engineering
Address: Bd. Vasile Pârvan, No. 2, RO300223, Timisoara
Phone: (+40) 256 403 430
Mobile: (+40) 745 180 818
E-mail: stefan.kilyeni@upt.ro
Web: www.et.upt.ro

BIOMASS SOURCES INTEGRATION IN THE ROMANIAN POWER SYSTEM. CASE STUDY FOR TIMISOARA AREA

Goal of the project

Power system analysis and optimization for the biomass sources integration in the Timisoara area of the Romanian Power System (Enel Banat Distribution Operator).

Short description of the project

The renewable energy sources represent an important issue for the Romanian and EU energy policy and sustainable development strategy. The projects refer to biomass sources integration in the Timisoara area of the Romanian Power System (Enel Banat Distribution Operator). The analysis has been performed for the North-Western, Western, Central and South-Western part of the System. Various operating condition, with the consumption forecast for 2018 and 2023, were considered, taking into account all the renewable energy sources (wind, solar, biomass, hydro).

Project implemented by

- Enel Distribuție Banat
- Cons Electrificarea Instal Timisoara

Implementation period

2014-2015

Main activities

- power system data base validation;
- Enel Banat distribution network modeling and operating condition analysis;
- power consumption and renewable energy generation forecast;
- power flow computing for various operating condition of the North-Western, Western, Central and South-Western part of the Romanian Power System (peak and minimum type regimes, 2013, 2018, 2023);
- contingency analysis, in the presence / absence of the renewable energy sources.



Results

- power flow corresponding to 2013 year and forecasted 2018 and 2023 years;
- power flow corresponding to the medium voltage electrical network (Enel Banat Timisoara area);
- voltage value without / with the new producers;
- quick / slow maximum voltage variation value for critical buses;
- transformer loading without / with the new producers;
- power flow through the power system elements and loading level;
- integration solution validation and system reinforcement recommendations (if necessary).

Applicability and transferability of the results

Knowledge transfer to other photovoltaic power plants developers and designers. Electrical distribution network operator (Enel, CEZ, EON, Electrica in Romania).

Fields of interest

- photovoltaic energy sources;
- other renewable energy sources;
- renewable sources' integration in the power systems;
- distribution network operators.

Research Centre

Research Centre for Power Systems Analysis and Optimization

Financed through/by

Cons Electrificarea Instal, total value: 9.424 RON

Research team

Stefan KILYENI, Constantin BARBULESCU, Attila SIMO, Annamaria KILYENI

Contact information

Prof. Ștefan KILYENI, PhD
Department of Power Engineering
Address: Bd. Vasile Pârvan, No. 2, RO300223, Timisoara
Phone: (+40) 256 403 430
Mobile: (+40) 745 180 818
E-mail: stefan.kilyeni@upt.ro
Web: www.et.upt.ro

DOBROGEA ELECTRICAL DISTRIBUTION NETWORK ANALYSIS AND OPTIMIZATION

Goal of the project

Distribution network real technical losses evaluation for Enel Dobrogea Distribution System Operator. Power flow computing for various operating condition of the Southern and South-Eastern part of the Romanian Power System (peak and minimum type operating conditions) has been performed.

Short description of the project

The study was conducted for Enel Dobrogea Distribution System Operator. An algorithm is proposed by the authors being able to compute the load dependent and non-dependent technical losses. The analysis has been performed for the Southern and South-Eastern part of the Romanian Power System. Quantitative and qualitative on-field measurements are provided and discussed, followed by the technical losses computing based on the provided algorithm. Different necessary scenarios for the distribution network operator have been taken into consideration highlighting the optimal operating conditions. The wind farms operating in that area have been considered. Their influence (considering various operating conditions) over the real technical losses' value has been analyzed.

Project implemented by

- Enel Distribuție Dobrogea
- Servelect Cluj-Napoca

Implementation period

2014-2015

Main activities

- on-field power flow monitoring in case of several overhead lines;
- algorithm development for technical losses evaluation;
- electrical distribution network modelling;
- optimal power flow considering different scenarios;
- wind farm modelling;
- comparison and analysis based on the these approaches.

Results

- algorithm used for technical losses evaluation;
- electrical distribution network simulation model;
- technical losses' reduction methods.

Research Centre

Research Centre for Power Systems Analysis and Optimization



Applicability and transferability of the results

The algorithm used for technical losses evaluation is able to be applied in case of any distribution network operator. Also, based on the achieved experience, other (or similar) technical losses reduction methods could be highlighted in case of other distribution operators.

Fields of interest

- distribution network analysis;
- technical losses computing;
- loss reduction methods;
- distribution system operators.

Financed through/by

Servelect Cluj-Napoca, total value: 9.796 RON

Research team

Stefan KILYENI
Constantin BARBULESCU
Attila SIMO
Annamaria KILYENI

Contact information

Prof. Ștefan KILYENI, PhD
Department of Power Engineering
Address: Bd. Vasile Pârvan, No. 2, RO300223, Timisoara
Phone: (+40) 256 403 430
Mobile: (+40) 745 180 818
E-mail: stefan.kilyeni@upt.ro
Web: www.et.upt.ro

ACTUAL TOPOLOGIES AND COMPONENTS FOR THREE-PHASE POWER FACTOR (PFC) FOR GRID TIED INVERTERS

Goal of the project

The Customer is a leading supplier for grid-tied motor control inverters for residential White Good applications like washing machines. It expects the market for inverters in residential ambient with power levels of up to 4kW to grow fast. For these inverters a new interface for residential grids must be designed which is EMC-conform. White Good applications with a power level of up to 1 kW uses passive chokes to fulfill the harmonic limits for the mains current drawn from the grid. The Subject of this contract is the compilation of a study dealing with the analysis and evaluation of current topologies and solutions for the three phase power factor correction (PFC) for 400V mains voltage.

Short description of the project

The evaluation of the current topologies was done in regards to electromagnetic compatibility (EMC) requirements including radio frequency interference (RFI) which is very important in the residential ambient. In a second step was decided if a standard PFC controller is used, or if the motor control DSC will also control the PFC power stage later on in the final design. For the 4 most promising topologies the efficiency versus output power (0-110%) calculation and filter requirement analysis (RFI and harmonics (EN 61000-3-2)) were done in an accurate approach to have a confident decision base. For these 4 topologies the losses in semiconductors (conduction and switching losses) and passive components (inductors, capacitors and EMI filter) were calculated. Two different topologies were selected by Diehl-Controls for prototype build for verification.

Project implemented by

Diehl AKO Stiftung & Co. KG Germany

Implementation period

6.01.2014 – 15.07.2014

Main activities

- Analysis of actual publications for three phase power factor correction (PFC) for 400V mains voltage for the power range of 1.5 kW up to 10 kW.
- Evaluation of current publications and state of the art in this field;
- Modeling and simulation

Research centre

Research Centre for Smart Energy Conversion and Storage

Fields of interest

It regards the market of grid-tied motor control inverters for residential White Good applications like washing machines. For these inverters a new interface for residential grids must be designed which is EMC-conform. White Good applications.

Financed through/by

Diehl AKO Stiftung & Co. KG Germany.

Results

- Analyzing all relevant three phase power factor correction (PFC) topologies currently existing for the power range of 1.5 kW up to 10 kW (passive PFC: single diode bridge rectifier system with smoothing inductor on the ac/dc side, passive 3-rd harmonic injection, multi-pulse rectifier system; low-frequency active PFC; high-frequency active PFC: phase modular system, direct three-phase system, buck type for 350 V dc bus, boost type; hybrid systems: 3-rd harmonic injection, combination of diode rectifier and dc/dc converter system (buck type – for 350 V dc bus, boost type), electronic reactance based rectifier system);
- Analyzing the currently existing methods for switching patterns and current sensing with high speed controllers;
- A decision matrix was prepared for different topologies;
- Two different topologies were be selected by Diehl-Controls for prototype build for verification.

Applicability and transferability of the results

Patentable inventions or parts in such inventions (hereinafter „inventions“) made by one or several employees of the University within the course of carrying out the study considered here shall be notified and offered for transfer to the Customer by the University forthwith. Simultaneously, the University shall make available to the Customer any and all information potentially relevant for a realistic evaluation of the intrinsic value of such invention – as far as possible in writing.

Research team

- Associate Prof. Sorin MUȘUROI, PhD(as project manager);
- Associate Prof. Alexandru HEDEȘ, PhD
- Assistant Mihaela Codruța ANCUȚI, PhD
- Assistant Marcus SVOBODA
- Prof. Dorin POPOVICI
- Prof. Nicolae MUNTEAN

Contact information

Assoc.Prof. Sorin Mușuroi, PhD
Faculty of Electrical and Power Engineering
Address: Bd. Vasile Pârvan, No. 2, RO300223, Timisoara
Phone: +40 256 403462
E-mail: sorin.musuroi@upt.ro

HARDWARE IN THE LOOP WIND/HYDRO TURBINES EMULATORS

Goal of the project

The project was focused on design and testing a “Hardware-in-the-loop” (HIL) wind /hydro turbines emulators, for research and design activities in the field of renewable energies.

Short description of the project

The research and design activities in the field of conversion and control systems for renewable energy applications need to have the possibilities to evaluate the performances of the prototypes in various conditions. In laboratory such tests can't be easy performed because it is difficult to have the entire, real, equipment, and the corresponding input energy parameters.

In such cases, the emulations technologies can be used.

A wind/hydro HIL consists essentially of: a software part which implements the mathematical model of the turbine, and a physical part that provides the similar static and dynamic characteristics as the real studied system.

The HIL structure in this project contains: a dSPACE control board, a voltage source inverter with direct torque control (DTC), a three phase induction machine (IM) with gearbox (GB) – the wind turbine equivalent, and a permanent magnet synchronous generator (PMSG) – the real system generator, with resistive load (Fig. 1).

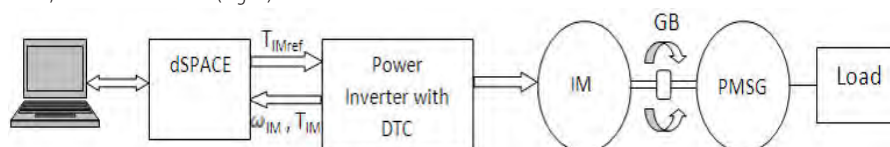

The emulator control was implemented in Matlab/Simulink and it runs in real time on dSPACE board. The control output signal (torque reference T_{IMref}) is send to the DTC inverter, which returns the real (estimated) IM torque (T_{IM}) and the drive (estimated) rotating speed (ω_{IM}).

Project implemented by

National Institute of Research and Development in Electrochemistry and Condensed Matter

Implementation period

2014

Financed through/by

OXYGEN Computers Ltd. Timișoara, România

Main activities

- Wind/hydro turbines mathematical model implementation;
- Design the entire system and the software elements;
- Testing and validation the emulator for various simulated input energy parameters and different control and conversion systems.

Results

- A full scale prototype (Fig. 2), with various software packages.



Applicability and transferability of the results

- The possibility to produce such equipment for research, design and testing companies in the field of renewable energies.
- Consultancy, design and testing activities for developers of power electronics and control equipment for energy conversion systems.

Research Centre

Research Centre for Smart Energy Conversion and Storage

Research Team

Nicolae MUNTEAN, Ciprian ȘORÂNDARU, Octavian CORNEA, Alexandru HEDEȘ, Dan HULEA

Contact information

Prof. Nicolae MUNTEAN, Ph.D.
 Department of Electrical Engineering,
 Address: Str.V. Pârvan, No. 2, RO300223, Timisoara
 Phone: (+40) 256 403 450
 E-mail: nicolae.muntean@upt.ro
 Web: www.et.upt.ro

REMOVAL OF BITTER TASTE FROM LINSEED OIL OBTAINED BY COLD PRESSING

Goal of the project

Removal of the bitter taste in unrefined cold pressed linseed oil, to make it more appealing for human consumption.

Short description of the project

Linseed oil has been used for a very long time as basis in oil paint and for linoleum fabrication, based on its short drying time and ability to form an uniform film. These qualities originate from the high content in unsaturated fatty acids, mostly α -linolenic acid (omega-3) and linoleic acid (omega-6) together with oleic acid. The high content in unsaturated fatty acids and the high percent of omega-3 and omega-6 made linseed oil very attractive for the human food industry, as well. However, there are some drawbacks concerning its utilization for human consumption, like as the susceptibility to oxidation during the extraction process and the unpleasant bitter taste that begins to develop after only a few days.

The most commonly used extraction method of linseed oil designated for human consumption is cold pressing, which leads to less oxidation.

As bitter taste develops far too early to be attributed to fatty acid oxidation, the main objective of the project is identification and removal of the components responsible for this deficiency. The implemented method must be in concordance with organic production regulations.

Project implemented by

Faculty of Industrial Chemistry and Environmental Engineering,
Department of Organic Chemistry and Engineering of Natural
Organic Compounds

Implementation period

01.08.2014 – 31.07.2015



Main activities

1. Evaluation of linseed oils from obtained by cold pressing of different cultivars, to determine the most convenient one for the production of good quality organic cold pressed linseed oil for human consumption;
2. Gas-chromatographic analysis for determination of the fatty acid profile;
3. HPLC and HPLC-MS analysis for identification of the compounds responsible for the bitter taste.
4. Influence of different factors on the oxidation of the oil;
5. Removal of the bitter taste by procedures compatible with the organic production regulations.

Applicability and transferability of the results

The results of this project will be used to develop a process for the organic production of cold pressed linseed oil, with improved marketability than the presently commercialized product.

Research Centre

Research Centre in Organic, Macromolecular and Natural Compounds
Chemistry and Engineering

Financed through/by

S.C. SOLOVERDE S.R.L. Timișoara

Research team

Eng. Claudiu MARCU
Asist. Prof. Cristina PAUL, PhD
Eng. Anamaria TODEA
Prof. Francisc PETER, PhD

Contact information

Prof. Francisc PETER, PhD
Faculty of Chemistry and Environmental Engineering
Address: C. Telbisz No. 6, RO300001 Timisoara
Phone: (+40) 256 404 216
Mobile: (+40) 745 637 530
E-mail: francisc.peter@upt.ro
Web: www.chim.upt.ro

MONITORING THE QUALITY OF WASTES FROM TECHNOLOGICAL PROCESS

Goal of the project

The project objective is to monitoring the quality of wastes from tehnological process.

Short description of the project

During the project various parameters of wastes are analyzed periodical from samples collected by the beneficiaries. The analyzed parameters and the times for the samples collections are commonly agreed by the beneficiaries and by the execution team. The analysis of the main parameters for the monitoring the quality of wastes are required for their storage according to law.

Project implemented by

Faculty of Industrial Chemistry and Environmental Engineering.
Department of Applied Chemistry and Engineering of Inorganic
Compounds and Environmental.

Implementation period

01.10.2014-01.10.2015

Main activities

- During the project will be analyzed the volatile organic compounds and (COV) analyzed the waste from Waste Water Treatment.
- Its determinates the concentration of the following parameters: Cr, Cu, Ni, Cd, Pb, Nt, Pt, pH, humidity and loss on ignition from water.
- The main parameter are analyzed dailies and other are analyzed monthly in accordance with the achieving plan established by the both parts involved in the project.

Applicability and transferability of the results

The results are consistent with the legislative framework in force.

Research Centre

Research Centre for Environmental Science and Engineering

Financed through/by

Research-Development and Consultancy Contract with S.C. FLEXTRONICS ROMANIA S.R.L.

Research team

Mihaela CIOPEC, PhD

Contact information

Mihaela CIOPEC, PhD
Department of Applied Chemistry and Engineering of Inorganic
Compounds and Environmental.
Address: Bd. Vasile Parvan, No. 6, R0300223, Timisoara
Phone: (+40) 256 404 192
Mobile:)+40) 722 806 880
E-mail: mihaela.ciopec@upt.ro

EXPERTISE ON DRINKING WATER LOSSES IN WATER SUPPLY SYSTEMS IN THE AREA OF OPERATION OF AQUATIM S.A.

Goal of the project

Expertise on drinking water losses in water supply systems in Timisoara

Short description of the project

Within expertise ,the following factors that influence water losses in a water supply system were analyzed:

- the age of the distribution networks
- the material used in distribution networks
- location and the execution of the distribution networks
- the corrosion of the networks
- the operating mode of the networks and the working pressure
- the density of connections per kilometer of distribution network (connections, fountains , hydrants)
- The number of accidents . The quality and execution time of distribution

Project implemented by

AQUATIM S.A.

Implementation period

01.05.2014-17.05.2014

Main activities

- Managing water loss is a complex technical problem and it takes a long time (20-40 years) to achieve. It involves a variety of factors in each system as well as technological progress in the field. In this framework there are developed the following concepts : a systematic approach , technical and financial support and long-term commitment.
- Splitting water supply system in counted sectors enables directing the detection activity in that part of the distribution system with the largest loss, it allows to identify the investments needed and clasify investments in order of priority. In this regard , Timisoara's distribution network was divided into 19 sectors, and for two of them the designing and implementing procedures have started.

Research Centre

Research Centre for Hidrotechnics

Financed through/by

AQUATIM S.A.

Research Team

Constantin FLORESCU, Ion MIREL, Cristian STĂNILOIU,
Carabet Adrian CARABET, Corneliu Eusebiu PODOLEANU

Results

- Analyzing the effects of AQUATIM strategy applied over the years throughout the area of operations, there can be observed a reduction in physical losses from over 40 % in 2002 to below 35% in 2013.
- Therefore , the decrease of relevant losses can be achieved over several years of efforts , the more it tends to lower the levels of losses the more difficult the process becomes, which is why there must always be a balance between the losses and costs of repair / rehabilitation.
- A continuous concern of the AQUATIM leaders is the continuous improvement of personnel and the acquirement of special equipments . The loss detection team from 2012 was equipped with a device for Prelocation defects called " Logger noise and frequency for monitoring piping networks" which simultaneously measures the noise level and frequency spectrum of the water loss .
- With this equipment, in 2013, there were detected with 220 % more conduction defects in the water distribution network of Timisoara City, which did not come up in the year 2012. This led to a visible reduction of real losses .

Applicability and transferability of the results

Currently, AQUATIM extended their active management strategy concerning the tracking of the losses in all operating area. Thus were audited all water distribution systems in the grounds surrounding Timisoara, and in the future there will be audited the water distribution systems of the localities belonging to the Subsidiary.

A continuous concern of the AQUATIM leaders is the continuous improvement of personnel and the acquirement of special equipments . The loss detection team from 2012 was equipped with a device for Prelocation defects called " Logger noise and frequency for monitoring piping networks" which simultaneously measures the noise level and frequency spectrum of the water loss .

With this equipment, in 2013, there were detected with 220 % more conduction defects in the water distribution network of Timisoara City, which did not come up in the year 2012. This led to a visible reduction of real losses .

Contact information

Prof. Constantin FLORESCU, PhD
Department of Hidrotechnics
Address: Str George Enescu., No 1/A, RO300022, Timisoara
Phone: (+40) 256 404 091
Mobile: (+40) 722 418 160
E-mail: constantin.florescu@upt.ro
Web: <http://www.ct.upt.ro/hidro/index.htm>

BUILDING OF ENCOURAGEMENT AND SUPPORTING CENTER FOR SMALL AND MIDDLE SIZE ENTERPRISES IN TIMISOARA

Goal of the project

Tests for the determination of the concrete class

Short description of the project

There were made destructive tests on cast concrete samples for verification of the concrete class.

Project implemented by

BCO ISET COMPANY SRL TIMISOARA

Implementation period

2014

Main activities

- Mechanical tests on concrete samples

Results

- Establishing the concrete class.

Applicability and transferability of the results

- The results were presented during the laboratory classes with the students

Financed through/by

BCO ISET COMPANY SRL TIMISOARA

Research Centre

Politehnica University of Timisoara, Building Faculty

Research team

Lecturer Liana IURES, PhD

Contact information

Lecturer Liana IURES, PhD
Department of Hydrotechnical Engineering
Address: Str. Tr. Lalescu, No. 2, Timisoara
Mobile: (+40) 735155022
E-mail: liana.iures@upt.ro

TECHNICAL EXPERTISE DN 18 BAIJA MARE – SIGHETU MARMATIEI, PART B KM 15 + 000 – 38 + 104 AND PART E KM 52 + 202 – 62 + 234

Goal of the project

The project aims at drawing up a technical expert report and providing technical consultancy services in relation to the road pavement and the culverts on the mentioned sections of the national road DN 18 with a view to proposing a new road pavement solution

Short description of the project

The contract involves the elaboration and delivery of the Technical Expert Report, including investigations on site, technical consultancy, typical profiles and all necessary supporting documents; it implies sustaining the technical expert report in front of the Beneficiary's Technical Economical Committee.

Project implemented by

The project will be implemented by C.N.A.D.N.R. Bucuresti – D.R.D.P. Cluj for changing the solution proposed in the initial project.

Implementation period

2014-2015

Main activities

Multidisciplinary activity domain, comprising chapters of investigation concerning the degradation condition, of comparative calculations concerning the dimensioning of the proposed road pavement versus the newly proposed solution and engineering structures.

Results

By applying the results offered by the Technical Examination Report the newly proposed technical solution was accepted and will be implemented.

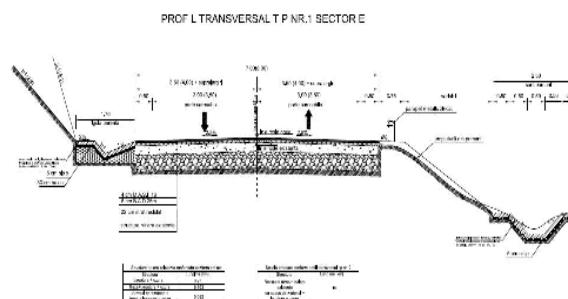
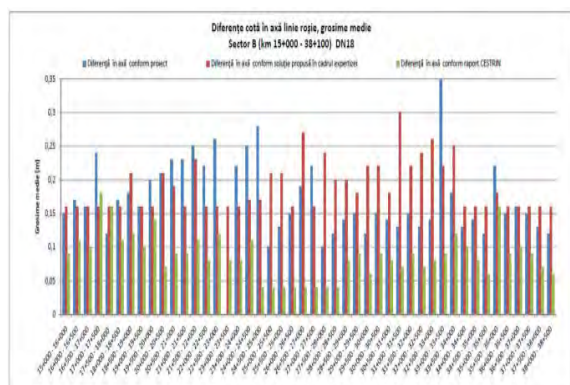

Applicability and transferability of the results

Based on the solutions offered by the Technical Expert Report, the newly proposed design solution is much more efficient due to the reduced time and cost of execution.

Financed through/by

C.N.A.D.N.R. Bucuresti - D.R.D.P. Cluj

Research Centre

Research Centre of Infrastructures for Constructions and Transportation -ICT-

Research team

Prof. Gheorghe LUCACI, PhD
Prof. Florin BELC, PhD
Assoc. Prof. Adrian BOTA, PhD.
Assist. Prof. Paul MARC, PhD.
Alin BUZURIU, PhD Student

Contact information

Prof. Gheorghe LUCACI, PhD/ Prof. Florin BELC, PhD
Department of Overland Communication Ways, Foundations and Cadastral Survey
Adress: Ioan Curea Street, No. 1, RO300224 Timisoara
Phone: (+40) 256 403 963/ (+40)256 403 965
E-mail: gheorghe.lucaci@upt.ro/ florin.belc@upt.ro
<http://www.ct.upt.ro/cctfc/index.htm>

TECHNICAL-ECONOMICAL DOCUMENTATION REGARDING THE REHABILITATION MEASURES OF THE EMBANKMENT “PRAG 09 – INTERNATIONAL AIRPORT SIBIU”

Goal of the project

The purpose of the technical-economical evaluation was to design the necessary construction works for the embankment rehabilitation of “Prag 09 – International Airport Sibiu”, including estimation and detailing of the necessary costs for execution of the construction works and the technological stages of execution.

Short description of the project

The extension of the Airport runway, within the modernization and expansion works of the International Airport Sibiu, required achieving an embankment up to 28 m height in the western direction. On August 2010, at the western end of the Airport runway, a collapse of the embankment has occurred, manifested through the fall of the soil mass on a depth of approximately 10 m in the runway axis and approximately 3–4 m on the edges of the embankment. The dimension of the collapsed area is approximately 250 m in length and 100 m wide.

The collapse of the tall embankment from the western part of the International Sibiu Airport was a very complex phenomenon, where numerous factors concurred, including the foundation ground, embankment profile, fill material used at the execution of the embankment, faults in the collection and drainage of the surface water, implemented drainage system.

Project implemented by

Given the fact, that this technical-economical evaluation is part from a judicial expertise, the project will be implemented at the end of the trial settlement agreement in which the International Airport Sibiu, designer, consultant and constructor are part of.

Implementation period

2014–2015



Main activities

Multidisciplinary activity domain, comprising chapters of soil mechanics, foundation engineering, geodesy, roads and engineering structures.

Results

By applying the solutions given by the technical-economical evaluation, the resistance and the stability of the embankment will be fulfilled, thus ensuring the integrity of the runway and normal landing and departure conditions of airplanes at the International Airport Sibiu.

Financed through/by

International Airport Sibiu

Research Centre

Research Centre of Infrastructures for Constructions and Transportation -ICT-

Research team

Professor Marin MARIN, PhD.
Senior Lecturer Octavian ROMAN, PhD.
Senior Lecturer Monica MIREA, PhD
Senior Lecturer Alexandra CIOPEC, PhD
Assistant Professor Luiza ROMAN, PhD.

Contact information

Assistant Professor Paul MARC, PhD
Department of Overland Communication Ways, Foundations and Cadastral Survey
Address: Ioan Curea Street, No. 1, RO300224 Timisoara
Phone: (+40)256 403 972
E-mail: paul.marc@upt.ro
Web: <http://www.ct.upt.ro/cctfc/index.htm>

RESEARCH AND MONITORING EMITTED AIR POLLUTANTS FROM FLUE GASES

Goal of the project

Identification, evaluation and monitoring of air pollutants, NO, NO₂, NO_x, CO, CO₂, O₂, NH₃, VOC, Zn, particles and thermodynamic parameters from several sources at Berg Banat Făgăraș zinc plating plant.

Short description of the project

The project consists in quarterly measurements of air pollutants resulted from the zinc plating main activity of the BERG BANAT Făgăraș branch plant. Thru these measurements the plant operator tunes its equipment's both for productivity and quality of its products and environmental protection.

Project implemented by

Politehnica University of Timisoara/ Faculty of Mechanical Engineering

Implementation period

18.03.14 – 22.12.14

Main activities

- Quarterly measurements episodes for air pollutants NO, NO₂, NO_x, CO, CO₂, O₂, NH₃, VOC, Zn, particles.
- Thermodynamics parameters of flue gases and residuals are also monitored to optimize the zinc plating procedures.

Results

An extensive database for main air pollutants for large zinc plating industrial units.

Applicability and transferability of the results

- Zinc Plating emissions,
- Thermodynamics,
- Environmental engineering,
- Environmental protection,
- Combustion.



Financed through/by

BERGBANAT, Fagaras Branch

Research Centre

Research Center for Thermal Machines and Equipment, Transportation and Pollution Control

Research team

Francisc POPESCU
Gavrilă TRIF-TORDAI
Adrian Eugen CIOABLĂ

Contact information

Assist. Prof. Francisc POPESCU, PhD
Department of Mechanical Machinery, Equipment and Transportation
Address: Bv. Mihai Viteazu no.1, Timisoara 300222
Phone: (+40) 256 403666
Mobile: (+40) 721 832730
E-mail: francisc.popescu@upt.ro
Web: www.mec.upt.ro

RESEARCH REGARDING SOLID AND GASEOUS EMISSIONS EMITTED BY PYROLYSIS INSTALLATION

Goal of the project

Evaluation of a new pyrolysis installation impact on the suburban environment

Short description of the project

The research partner has purchased and further developed a pyrolysis installation for thermal treatment of Polyethylene Terephthalate (PET). The main product is a high density molasses with a high energy content to be used as renewable energy source. The byproduct is biogas and our goal is to evaluate its quality and suitability to be used as main fuel for pyrolysis process.



Project implemented by

Politehnica University of Timisoara/ Faculty of Mechanical Engineering

Implementation period

22.04.14 – 22.12.14

Main activities

In-situ measurements of SO₂, NO (NO+NO₂), CO, CO₂, O₂, VOC, heavy metals, suspended particles emissions and thermodynamic parameters

Results

- Evaluation of pyrolysis efficiency.
- Evaluation of installation environmental impact.
- Evaluation of biogas quality.



Applicability and transferability of the results

- PET pyrolysis techniques.
- Renewable energy sources.
- Urban waste management.

Financed through/by

POWEROIL COMPANY Timisoara

Research Centre

Research Center for Thermal Machines and Equipment, Transportation and Pollution Control

Research team

Francisc POPESCU
Gavrilă TRIF-TORDAI
Adrian Eugen CIOABLĂ

Contact information

Assist. Prof. Francisc POPESCU, PhD
Department of Mechanical Machinery, Equipment and Transportation
Address: Bv. Mihai Viteazu no.1, Timisoara 300222
Phone: (+40) 256 403666
Mobile: (+40) 721 832730
E-mail: francisc.popescu@upt.ro
Web: www.mec.upt.ro

NUMERICAL SIMULATION OF HEAT CONVECTION FOR A WASHING MACHINE HEATING SYSTEM FUNCTION OF THE THICKNESS OF LIMESTONE LAYER

Goal of the project

The project goal is investigate by numerical simulation the limestone accumulation on electrical heating elements for domestic and industrial applications.

Short description of the project

Many industrial applications require the use of electrical heating elements with wires arrangements, to functioning as heating device for industrial and domestic applications. Such devices have to be designed according to the availability of space in the device containing them. A measure of the evolution of such equipment, therefore, is the reduction in size, or in occupied volume, accompanied by the maintenance or improvement of its performance. When the heaters accumulates a lot of limestone, part the heat generated by the heating wire is transferred to the thermal fuse, which opens the heating circuit. Thermal fuse acts as safety device by interrupting the current in case that the heater is energized when it is not completely immersed in water.

Project implemented by

Politehnica University of Timisoara, Research Centre for Engineering of Systems with Complex Fluids

Implementation period

20.08.2014 - 04.09.2014

Main activities

The main activities consisted in:

- heat transfer simulation at imposed operating conditions using geometry reconstruction of the heat exchanger,
- computational domain discretization,
- problem setup for flow simulation with heat transfer,
- post processing and data analysis .

Results

The results will help to design new heating elements, increasing the performance and lifetime.

Applicability and transferability of the results

Knowledge transfer and increase the database of the company at different operating conditions which may appear in reality.

Financed through/by

- Zoppas Industries Romania SRL
- IRCA - Italy

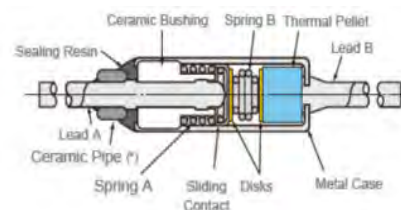

SFH type thermofuse after operation

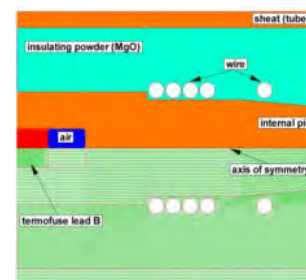

Computational domain mesh. Both structured and unstructured mesh is used in order to obtain the optimal mesh size for a accurate results.

Experimental measurements of the heat exchanger



Research team

Assistant Professor Alin Ilie BOSIIOC, PhD
Sandor BERNARD, PhD, Senior Researcher
Professor Romeo SUSAN-RESIGA, PhD
Mariana TODIRUTA, Eng, Researcher

Contact information

Assist. Prof. Alin Ilie BOSIIOC, PhD
Department Mechanical Machines, Equipment and Transportation
Address: Str. Bv. Mihai Viteazu, No. 1, Postal Code 300222, Timisoara
Phone: (+40) 256 403 692
Mobile: (+40) 727 988 895
E-mail: alin.bosioc@upt.ro
Web: <https://mh.mec.upt.ro/>

RESEARCH AND TECHNICAL ASSISTANCE FOR IMPROVING THE GEOMETRICAL PRECISION OF AUTOMOTIVE PRODUCTS

Goal of the project

To improve the quality of the drawings representation and hence the dimensional and geometrical precision of the injected plastic parts used especially in the automotive industry.

Short description of the project

Geometric product specification (GPS) is a language for communicating engineering design specifications. In this research have been studied different ways of representation of molded parts in accordance with the principles of GPS and a method of tolerance allocation that uses optimization techniques to assign component tolerances that minimize the cost of production of an assembly. 3D measuring principle of the plastic parts has been also analyzed. For each plastic parts studied, used in the automotive industry, has been developed the optimal reference system and strategy for measuring according to the characteristics of the part and dimensional and geometrical part precision requirements.

Project implemented by

Design Department, S.C. Continental Automotive Romania S.R.L.

Implementation period

03.03.2014 - 30.05.2014

Main activities

In a dynamic area as the automotive is difficult to keep up with all the requirements and technical news occurring. The research mission is to overcome these difficulties by an optimisation approach in the design phase of the plastic parts, that combine the following major activities:

- analyzing and deepening the different ways of drawings representation of molded parts according the GPS principles, that includes all the symbols, definitions, mathematical formulae, and application rules necessary to embody a viable engineering language
- tolerance allocation using least cost optimization
- 3D measuring principles of the plastic parts.

Results

Transfer to the technical staff of the company the design methods according to the GPS, ISO standards, tolerance analysis and 3D measuring principle in order to improve the quality of the products.



Applicability and transferability of the results

All the research results are useful, especially, in the design department. The methods developed can be used for design optimization of different plastic parts even in other companies.

Financed through/by

S.C. Continental Automotive Romania S.R.L.

Research Centre

Integrated Engineering Research Center

Research team

Assoc. Prof. Aurel TULCAN, PhD
Assist. Prof. Dan Teodor MĂRGINEANU, PhD
Assist. Prof. Liliana Georgeta TULCAN, PhD

Contact information

Assoc. Prof. Aurel TULCAN, PhD
Materials and Manufacturing Department
Address: Bld. Mihai Viteazu nr.1, RO300222, Timisoara
Phone: (+40) 256 403 619;
Email: aurel.tulcan@upt.ro

RESEARCH AND INVESTIGATION REGARDING THE IMPROVEMENT OF THE DIMENSIONAL PRECISION OF THE ENGINE INJECTED PLASTIC PARTS

Goal of the project

To transfer knowledge to the technical staff in order to improve the quality of their parts by understanding the geometrical product specification method (GPS) and the assumptions and risks that go along with each tolerance analysis method.

Short description of the project

- The first part of the project analyzed the geometrical product specifications method (GPS) and the ISO standards used for the engine plastic injection parts from the automotive industry.
- In the second part, according with project items the group of technical staff has been familiarized with statistical knowledge used in statistical process control, multi-Dimensional Tolerance Analysis (Manual and Automated Method) and Minimum-Cost Tolerance Allocation.

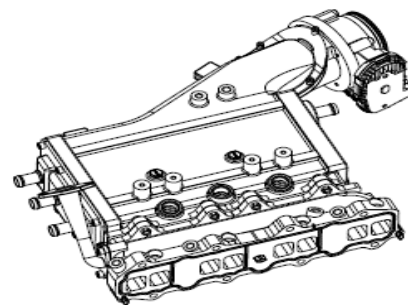

Project implemented by

Design Department, S.C. MAHLE Componente de motor S.R.L., Timișoara, Romania

Implementation period

06.05.2014-30.05.2014

Main activities

- The technical staff, assisted by the research team analyzed the requirements for the parts and how to make drawings according to the ISO standards using the Geometrical products specifications method.
- Also, they made a tolerance analysis, that is the process of taking known tolerances and analyzing the combination of these tolerances at an assembly level.
- For the specific parts has been defined the process for analyzing tolerance stacks. It has shown how to set up a loop diagram to determine a nominal performance/assembly value and the techniques to calculate variation from nominal.

Results

Transfer of geometrical product specification, statistical knowledge and tolerance analysis methods to technical staff for improving the quality of technical documentation in the design phase and during the fabrication of the products.

Applicability and transferability of the results

The results of the project are applicable in the Mahle Company for improving the quality of their products and for increase the productivity. The experience accumulated with this project is very useful for monitoring and optimizing different products in other companies.

Financed through/by

S.C. MAHLE Componente de motor S.R.L., Timișoara, Romania

Research Centre

Integrated Engineering Research Center

Research team

Assoc. Prof. Aurel TULCAN, PhD
Assoc. Prof. Daniel STAN, PhD
Assist. Prof. Liliana TULCAN, PhD

Contact information

Assoc. Prof. Aurel TULCAN, PhD
Materials and Manufacturing Department
Adress: Bld. Mihai Viteazu nr.1, RO300222, Timisoara
Phone: (+40) 256 403 619;
Email: aurel.tulcan@upt.ro

NEW CLASSROOM MATERIALS FOR COMPUTER AIDED MATHEMATICS

Goal of the project

The project objective is to improve teaching practice, to develop GeoGebra applications which are useful to understand abstract mathematical notions and to produce dynamic and interactive documents dedicated to the first-year mathematics courses.

Short description of the project

All applets take advantage of GeoGebra's dual graphic view capability, which allow to simultaneously visualize two graphical representations and facilitates the study of transformations of the complex plane and of complex variable functions.

Project implemented by

Department of Mathematics and GeoGebra Institute of UPT

Implementation period

26.06.2012-01.06.2015

Main activities

- Weekly meetings with students at Geogebra Institute of UPT
- Support materials for life-long education of math teachers.
- Periodic uploads to GeoGebra Tube.

Results

- Applets for Calculus: Convergent sequence and its limit, The Taylor polynomial, Fourier series and Gibbs phenomenon, The Young's inequality, Random integral sum, The Cubic root of complex numbers, Simple convergence versus uniform convergence.
- Applets for Linear Algebra and Geometry: Linear transformations in the real plane and 2x2 matrices; Dynamically generated 2D curves, About oriented curves.
- Applets for Applied Mathematics: Differential equations and stability, About Shannon sampling theorem.

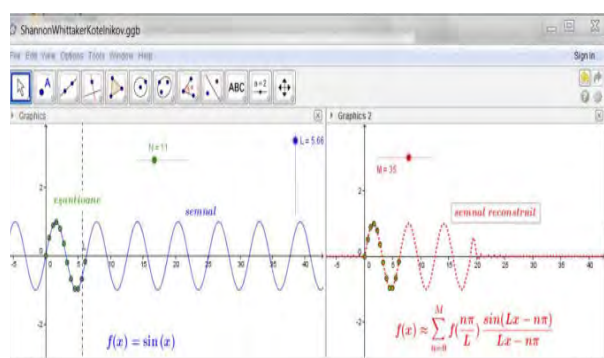
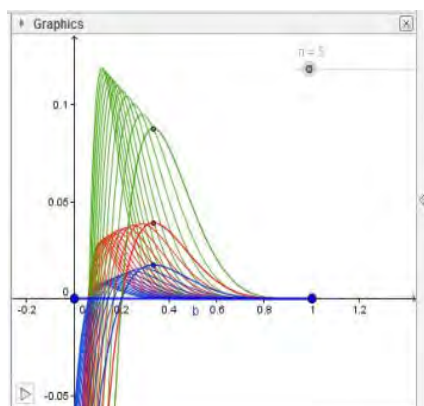

Applicability and transferability of the results

All GeoGebra applets can be classified as didactical modeling and are appropriate to be utilized in the classroom.

Financed through/by

- Department of Mathematics
- SC ANCA ELECTRIC SYSTEMS SRL, Timișoara

Research Centre

GeoGebra Institute of UPT

Research team

Assoc. Prof. Dr. Doru PĂUNESCU

Contact information

Assoc. Prof. Doru PĂUNESCU, PhD
 Department of Mathematics
 Address: Piata Victoriei No. 2, RO300006, Timisoara
 Phone: (+40) 256 403 099
 Mobile: (+40) 744 477 468
 E-mail: doru.paunescu@upt.ro
 Web: <http://www.mat.upt.ro/> and <http://geogebra.upt.ro/>

Patents

INVENTORS: HEPUȚ TEODOR, SOCALICI ANA, ARDELEAN ERIKA, ARDELEAN MARIUS, CONSTANTIN NICOLAE, BUZDUGA MIRON, BUZDUGA RADU
PATENT NO. 126946/2014

Tubular briquette from ferrous pulverous waste



The invention relates to a tubular briquette made of ferrous wastes as powder and smalls, meant to be used in the ferrous metallurgy, in reduction equipments, such as in pig-iron furnaces or in installations for the direct iron reduction from ores, with a view to obtaining iron sponge. According to the invention, the briquette is tube-shaped, having an external diameter $D = 60...70$ mm, an internal diameter $d = 20...25$ mm, the height $h = 40...45$ mm and having an external cylindrical surface, an internal cylindrical surface, two flat surfaces equal to each other, a cavity, and is obtained by the compression of a mixture in a mould, using a hydraulic press, the mixture comprising 40...60% steel foundry dust, 8...12% blast-furnace dust, 8...12% blast-furnace agglomeration slag, 5...9% iron scale, 5...8% coal dust, 5...8% the ferrous fraction of the steel foundry slag, 3...5% graphite, 2...4% bentonite, 2...4% lime and 4...8% water.

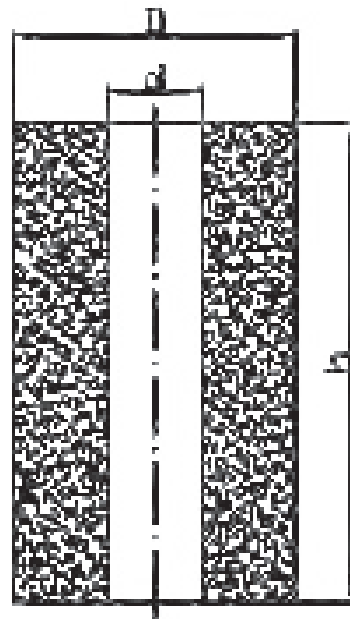

Patent Requests

INVENTORS: ICLĂNZAN TUDOR ALEXANDRU

INSTALLATION FOR COLLECTING GARBAGE

- The invention relates to an installation for collecting garbage in a public space or in the proximity of dwellings. According to the invention, the installation consists of some support and turret assemblies, respectively, the support assembly being placed underground and consisting of a pedestal plate, provided with a central opening, for the full access of a container, which is fixed on a pedestal, which delimits the mouth of an underground compartment, on the plate there being fixed three columns, which support, inside the compartment, a common reinforcing plate, so that a leading screw supported in the plates, actuates a leading nut mounted on a mobile intermediary support plate, whereon the container is placed, on the lower side of the intermediary plate, in front of the column opposite to the leading screw; there being placed a profiled apron roll, on a shaft supported by some supports fixed on the intermediary plate, the turret assembly consisting of a thin-walled semi-cylindrical cover, between some straight lateral walls thereof there being provided a lamellar protuberance which enables the supporting of the cover of the container in semi-opened position, on the semi-cylindrical cover there being provided a sectorial radial opening, closed by an oscillating semi-circular valve, which has an undercut frontal sector covered with a transparent plate (I) which allows the filling condition of the container to be viewed, the turret assembly made this way being tiltable into the discharging position due to some hinges by means of which it is attached to the support assembly.

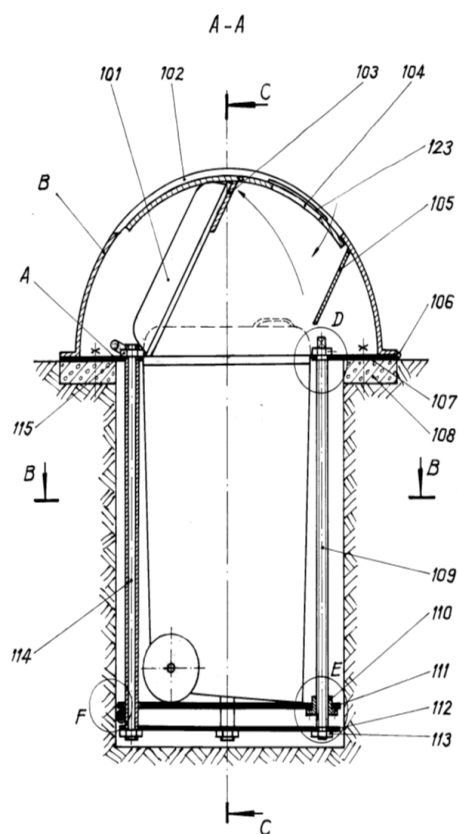

INVENTORS: ICLĂNZAN TUDOR ALEXANDRU

INSTALLATION FOR COLLECTING MUNICIPAL GARBAGE

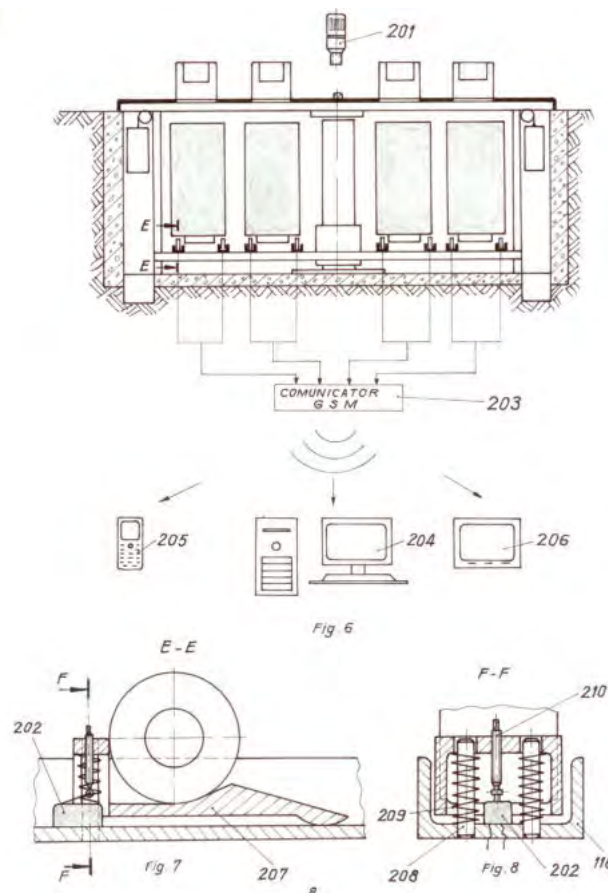

- The invention relates to an installation for collecting garbage in a public space or in the proximity of dwelling houses. According to the invention, the installation consists of a parallelepipedal concreted enclosure, wherein there may be vertically moved a parallelepipedal metallic frame which, at the upper side has a cover, consisting of many segments, provided with some turrets for supplying some containers placed within the frame on some rail-type supports, the frame touching with the base the ground of the enclosure, and its weight and that of the containers is balanced by two counter-weights, which are suspended by four cables at the upper side of the enclosure, an end of the cables being connected to the base of the frame, and the other end to the counter-weights, the cables passing over four rollers, placed at the corners of the structure of the frame, in the central part of the frame there being placed a sleeve with a certain clearance, which guides the outer end of a leading screw, which may rotate inside an actuating nut, mounted on a cylindrical support, which is supported, at the opposed end, on the lower part of the ground from the concreted enclosure, a bushing fixed in the lower side of the frame carrying out a sliding adjustment with the cylindrical support and, consequently, the vertically guided movement when the leading screw is rotated, during the lifting and lowering operations, the lifting and lowering of the frame structure bearing the containers may be carried out with a portable direct current gearmotor, by coupling them at the outer end of the leading screw by an operator.

INVENTORS: MICEA MIHAI VICTOR, STANCOVICI ANDREI, CREȚU VLADIMIR IOAN

SYSTEM AND METHOD FOR ORIENTATION AND RELATIVE LOCALIZATION OF AUTONOMOUS SUBSYSTEMS

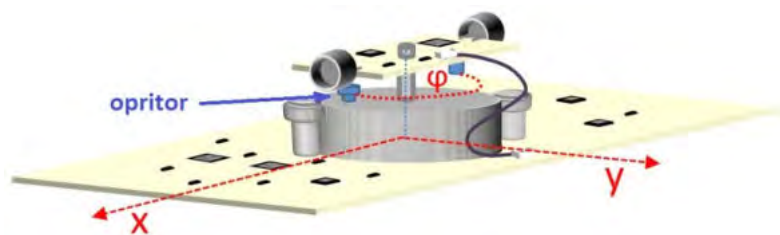

• The invention relates to a system and a method for orientation and relative localization of autonomous subsystems as related to a common reference system. According to the invention, the system consists of a set of autonomous subsystems, each of which are provided with an orientation and localization hardware device, and communicating by electromagnetic and mechanical waves, and a central node having the role of summarizing the coordinates, which can be a steady equipment or a preset system. The method, as claimed by the invention, comprises a first stage of subsystem localization based on mobility prediction, a second stage of localization by distributed processing and cooperation with the proximal subsystems and a third stage of coordinate summarizing and subsystem mobility management with a view to maintaining the localization accuracy coefficient at high values.

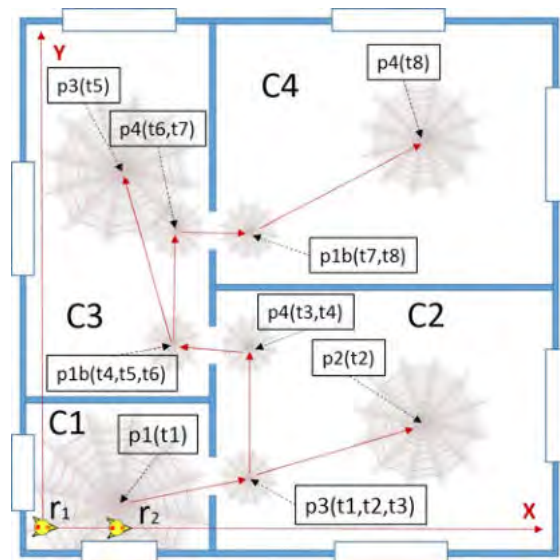

INVENTORS: POPA GABRIEL NICOLAE, POPA IOSIF, DEACONU SORIN IOAN

ELECTRONIC TIME RELAY FOR USE IN CONTROL INSTALLATIONS OF ELECTRIC DRIVERS, HAS TWO DELAY CIRCUITS WITH VARIOUS DELAYS

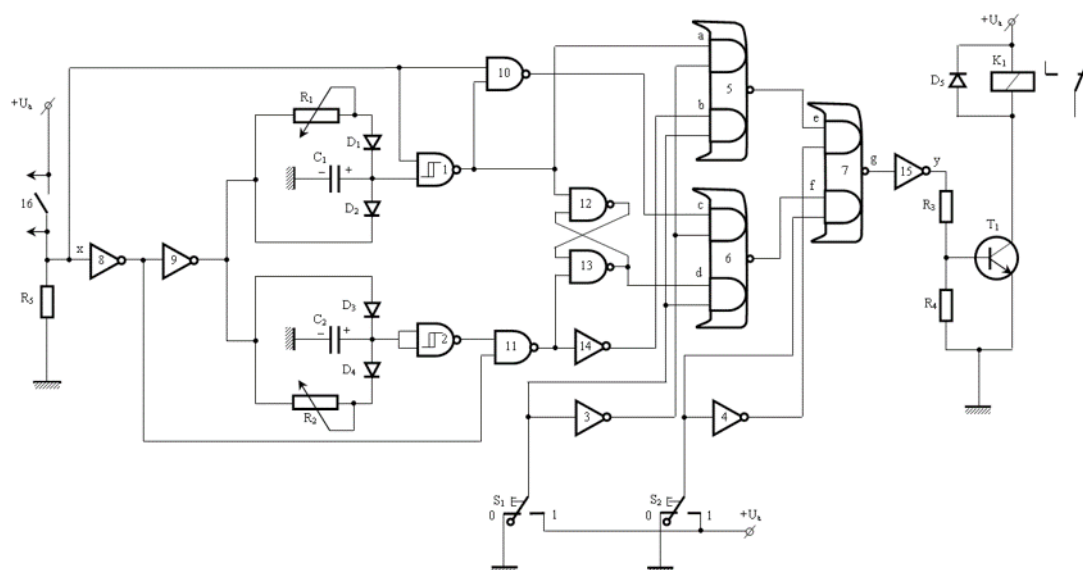

- The invention relates to an electronic relay for all normal functions, with actuating an electromagnetic relay which can be used in plants for the control of electric drives. Electronic time relay ensures that after the state of bi-positional switches, perform the following tasks: attracting delay, or delaying the release, or to keep it attracted a certain time, or delay the release of attracting mobile armature electromagnetic relay, with local control or from a command facility.
- The problem to be solved by the invention is to provide an electronic relay for all functions which are customary requirements by means of bi-positional switches in connection with AND-OR-NOT gates integrated circuits.
- The invention relates to an electronic time relay which may be used in the control installations of the electric drivers. According to the invention, the relay comprises two delay circuits (1, R1, C1, D1, D2; 2, R2, C2, D3, D4), with various delays, where to the command is transmitted by means of two inverters (8, 9), the output of the first delay circuit (1, R1, C1, D1, D2) being connected, on the one hand to the input of a first AND-OR-NOT gate (5), on the other hand through an AND-NOT gate (10), which has the other input connected to the input of the first inverter (8), to an input into a second AND-OR-NOT gate (6), and on the other hand to the SET input of a flip-flop circuit R-S (12, 13) which has the output connected to another input of the second AND-OR-NOT gate (6), and the second delay circuit (2, R2, C2, D3, D4) has the output connected to another AND-NOT gate (11) which has the other input connected after the first inverter (8) and whose output is connected, on the one hand, to the RESET input of a flip-flop circuit R-S (12, 13), and on the other hand, through an inverting gate (14) it is connected to an input of the first AND-OR-NOT gate (5), the outputs from the two AND-OR-NOT gates (5, 6) are connected to the inputs into a third AND-OR-NOT gate (7) whose output, through an inverting gate (15) and a logical amplifier with transistor (R3, R4, T1), controls an electromagnetic relay (K1), the functions of the electronic time relay being changed by means of two bi-positional switches (S1, S2) connected both directly and by means of some inverters (3, 4), to the free inputs of the three AND-OR-NOT gates (5, 6, 7) so as to allow the transmission, in four different ways, of the commands given from a contact (16) at the input of the first inverting gate (8), to the coil of the electromagnetic relay (K1).

Utility Models

INVENTOR: PAVEL ȘTEFAN

ELECTRIC INSTALLATION FOR DENTAL MEDICAL UNITS AIR DESINFECTION

The invention refers to an installation for air disinfection for dental medical units like a way for completion the cleaning and chemical disinfection measured in 10 minutes time of functioning.

The technical problem which the invention resolves, is the obtaining a fixed electric installation for air disinfection in dental medical units and it's incorporated in the general lighting installation, the commanding of the installation is made by a return press button, a general programming watch and a programing reel from the distance, which uses a telephone network (wired/GSM).

The electric Installation for dental medical units air disinfection is made from a light bull with a mirror lens, performance electronic ballasts and fluorescent lights with a color rendering index $Ra=94$ and color temperature of 5200K, between this is positioned a germicidal lamp UV-C with wavelength of 253.7mm and UV-C radiation of 15.0W. The fluorescent lights are used for general lighting and the germicidal lamp is used for disinfection the space destined for dental medical unit.

The installation's command made optionally by a return press button, a general programing watch and a programing reel from distance which uses a telephone network (wired/GSM).

The invention's advantages are:

1. Lower costs for production because the disinfection lamp is incorporated in the general lighting lamp;
2. The installation disinfects the air in 10 minutes time with the condition that the general lighting system has to be designed and built as required in terms of the lighting regulations;
3. Each hour monitoring germicidal lamp operating time required for installation's efficient maintenance;
4. The installation's possibility of scheduling the operation;
5. The possibility to connect the disinfected air and the remote ordering system through GSM network and telephone;
6. The energy efficiency through lower power consumption;
7. The safe operation of air disinfection facility;
8. The electrical control's simplicity;
9. The simple maintenance by cleaning or replacing the lamps dust when the number of operating hours expires.

Doctor Honoris Causa

DOCTOR HONORIS CAUSA

Professor Peter George Oliver FREUND – University of Chicago

Professor Peter George Oliver Freund was born on September 7th 1936 in Timisoara and graduated the “C. D. Loga” high school in 1953. He completed his undergraduate studies between 1953-1958 at the Electrotechnic Faculty of the Politehnica University (former Polytechnic Institute in Timisoara). He earned the diploma of engineer in 1958 with a diploma work under the guidance of Professor Plautius Andronescu, a prominent educator, who profoundly influenced his way of thinking for the entire career.

A fundamental feature of his scientific thought has been the fact that he has been convinced from the start of the necessity of a radical change in modern physics concerning perception of the concept of physical field and its dimensions. Consequently, throughout his career, he devoted himself to research and description of physical phenomena in spaces with a higher number of dimensions in the larger context of unification of physical fields. He obtained a series of pioneering results in the field of supersymmetry, in string theory (i.e. theory of elementary particles seen as extending in space – strings – rather than point like objects). He proposed a hypothesis in string theory, the so-called Freund-Harari conjecture whose validity has been confirmed in many experiments.



In the scientific world, Professor Freund is best known and praised mainly for his contributions in two-component duality, in multi-dimensional unification, in superstrings with 26 dimensions and in p-adic strings. Professor Freund authored or co-authored more than 400 scientific papers that he published or presented at scientific conferences in his field of expertise. Scientific databases (Scopus, Web of Knowledge or Google Academic) count almost 4500 citations of his work at the present time, and this number is constantly increasing.



Professor Freund demonstrated his creative capabilities not only in the scientific domain, but also in literature, by publishing volumes of memories and fiction. We remark his books: *A Passion For Discovery* (2007), *West of West End* (2008), *Tales in a Minor Key* (2012) and the very interesting one *Dialog across the Atlantic* (written through the Internet together with his friend from childhood, the writer Radu Ciobanu), of which two editions have been already issued.

Professor Emeritus

PROFESSOR EMERITUS

Professor Hans-Jörg BULLINGER - Fraunhofer Gesellschaft

Professor Hans-Jörg Bullinger is the Doctor Honoris Causa of the Politehnica University of Timisoara since 2004. Professor Bullinger was president of the Fraunhofer Society between 2002–2012 and is currently a member of the Senate at the Research Network. In 2013, he was awarded the Hans-Peter-Stihl prize for his achievements in the development of the Stuttgart region.

He began his career working as a manufacturer for the Daimler-Benz company in Stuttgart, after which he obtained a degree at the University of Stuttgart, graduating with a Master's degree and Ph.D. in Manufacturing. After two years of lecturing at the University of Hagen, Dr. Bullinger was asked to become a full-time lecturer at the University of Stuttgart.

Besides his role as chairman of the University, Dr. Bullinger is also the head of the Institute for Human Factors and Technology Management (IAT) and the Fraunhofer-Institute for Industrial Engineering (IAO).

At present, the Fraunhofer-Gesellschaft maintains more than 80 research units in Germany, including 59 Fraunhofer Institutes. The majority of the 17,000 staff are qualified scientists and engineers.



With its clearly defined mission of application-oriented research and its focus on key technologies of relevance to the future, the Fraunhofer-Gesellschaft plays a prominent role in the German and European innovation process.

Professor Bullinger is a member of acatech, the German academy of science and engineering.

1998: Order of the Federal Republic of Germany (Bundesverdienstkreuz), medal and ribbon, awarded for outstanding services to German science, industry and society,

2003: First Class Order of the Federal Republic of Germany (Bundesverdienstkreuz erster Klasse), awarded for extraordinary services to German science and research

2006: Order of merit of the Federal Republic of Germany for promoting the transfer of knowledge between science and industry

2009: Verdienstorden des Landes Baden-Württemberg (Merit of the State of Baden-Wuerttemberg)

2012: Leonardo European Corporate Learning Award in the "Thought Leadership" category.[2]

2013: International Fellow[3] of the Royal Academy of Engineering[4]

Habilitation Theses

EFFECTIVE TECHNIQUES TO ENHANCE IMAGES AND VIDEOS

Author: Cosmin ANCUȚI

Abstract

In this habilitation thesis are presented my research activity and the main academic results obtained after obtaining my PhD, from the second half of 2009 to date. In the following are described the main directions of my research in image processing and computer vision fields: color-to-grayscale conversion, image dehazing, fusion-based enhancing techniques, preprocessing techniques for computer vision applications and enhancing underwater images.

Color-to-grayscale conversion refers to mapping three dimensional color information onto a single dimension while still preserving the original appearance, contrast and finest details. We present the main contributions of our effective decolorization algorithm that preserves the appearance of the original color image. Image dehazing refers to the process of enhancing the visibility in images degraded by haze. In outdoor environments, light reflected from object surfaces is commonly scattered due to the impurities of the aerosol, or the presence of atmospheric phenomena such as fog and haze yielding images characterized by poor contrast, lower saturation and additional noise. In our work we developed an alternative approach to solving this challenging problem. Our technique is based on the remark that the distance from the observer to the scene objects is highly correlated with the contrast degradation and the fading of the object colors.

Image dehazing refers to the process of enhancing the visibility in images degraded by haze. In outdoor environments, light reflected from object surfaces is commonly scattered due to the impurities of the aerosol, or the presence of atmospheric phenomena such as fog and haze yielding images characterized by poor contrast, lower saturation and additional noise. In our work we developed an alternative approach to solving this challenging problem. Our technique is based on the remark that the distance from the observer to the scene objects is highly correlated with the contrast degradation and the fading of the object colors.

Preprocessing techniques for computer vision applications. Firstly, in our previous work we introduced a decolorization technique that is suitable to match images based on local feature points



Enhancing Underwater Images. We describe a technique published in our work that is able to enhance underwater images. It aims to yield a final image that overcomes the deficiencies existing in the degraded input images by employing several weight maps that discriminate the regions characterized by poor visibility.

The full abstract at:

http://www.upt.ro/img/files/2013-2014/doctorat/abilitare/Ancuti/Rezumat_abilitare_Cosmin%20Ancuti_lb_eng.pdf

Habilitation Commission

Prof.univ.dr.ing. Mihai DATCU
Universitatea Politehnica din București;
Prof.univ.dr.ing. Constantin VERTAN
Universitatea Politehnica din București;
Prof.univ.dr.ing. Radu VASIU
Universitatea Politehnica Timișoara

CONTRIBUTIONS TO THE BEHAVIOUR OF COMPOSITE ELEMENTS FOR BUILDINGS PLACED IN SEISMIC AREAS AND HIGH QUALITY CONSTRUCTION WORKS THROUGH MONITORING

Author: Daniel DAN

Abstract

The present thesis summarizes the research of activity, after the PhD thesis was defended at the Politehnica University of Timisoara and confirmed by the Ministry of Education and Research, on the basis of Order no. 3896 / 24. 04. 2003.

The habilitation thesis presents two main research activities that I performed and omits a series of activities considered secondary and complementary to the main ones.

My first research area consists in theoretical and experimental studies regarding the behaviour of steel composite elements for buildings placed in seismic areas.

This PhD research domain was further studied and supplemented with the discovery and the use of innovative composite solutions.

The second research area is focused on monitoring the structural health of special constructions or highly important buildings, on monitoring certain constructions in order to validate certain calculus principles. Within this research I have studied various applicative construction issues, i.e.: the subjects approached are closely connected to the execution activity and to the monitoring of the buildings behaviour in time. Therefore, I have applied new concepts for the energetic efficient buildings, as regards their construction and monitoring in order to validate the energetic performances.

In the field of the behaviour of steel concrete composite shear walls with high strength concrete I aim to:

- Identify innovative solutions for composite steel-concrete shear walls with partially encased profiles, for solid composite walls and with various configurations of openings;
- Find new technologies to make shear walls using fibre reinforced concrete;
- Strengthen composite shear walls using Fiber Reinforced Polymers as possible strengthening solutions for structural elements damaged under seismic events.



In the field of monitoring the structural health of special constructions or highly important buildings and monitoring certain constructions in order to validate certain calculus

principles I plan to:

- Find efficient solutions for sustainable buildings in Romania;
- Finish the research programme of monitoring the passive house and nearly energy building;
- Provide a practice guide based on recorded data.

The full abstract at:

http://www.upt.ro/administrare/dgac1/file/2013-2014/abilitare/Dan_Daniel/Abstract_Habilitation%20Thesis_Daniel_DAN_EN.pdf

Habilitation Commission

Prof. univ. dr. ing. Nicolae ȚĂRANU
Universitatea Tehnică "Gheorghe Asachi" din Iași
Prof. univ. dr.ing. André PLUMIER
Universitatea din Liege, Belgia
Prof. univ. dr. ing. Adrian IOANI
Universitatea Tehnică din Cluj

CONTRIBUTIONS TO THE BEHAVIOR OF STRUCTURES UNDER EXTREME LOADING

Author: Florea DINU

Abstract

The Habilitation Thesis presents the past activity of the candidate after defending the PhD Thesis at The Politehnica University Timișoara and also plans of future research and personal developments. The PhD Thesis, entitled "Behaviour of MR steel frames with semirigid joints" was prepared under the coordination of Acad. Dan Mateescu. The doctoral degree was confirmed by The Ministry of Education and Research, Order no. 1300/112/C, from 23.12.2004.

Within the period 2004-2014, most of activity concentrated on extending the research topics developed during the PhD period. Starting from the seismic behavior of steel framed buildings, performance based seismic design methodology and the factors that affect one of the key properties, i.e. ductility of members and connections, the research activity extended to other extreme actions, with the aim of providing a complete set of design requirements under any type of extreme loading. These new topics partially continued the previous activity, but there were also new topics that emerged from the previous activity. As a direct consequence of the research activity, efforts have been paid to bring these new concepts into real applications. Thus, there were several projects that may be viewed as innovative, from the point of view of the structural system, connections, detailing and use of materials or analysis techniques. For their innovative character, some applications have been awarded by prestigious national and international organizations.

A great support for the activity that followed after the PhD, may be attributed to the participation of the candidate to national and international projects and also to the cooperation with industrial partners. This can be justified by the publication of more than 40 papers, mostly in international conferences and journals. The main achievements and results are presented in detail in the Thesis.

In what concerns the future activities and development plans, the following research topics will be further developed or started:

- Guidelines for the collapse control performance based design of multi-story frame buildings against accidental actions



- Improved structural systems and application to buildings
- New structural systems based on removable dissipative members
- New hysteretic devices with improved damping characteristics
- Application of new braced systems to design of new buildings or for refurbishing existing buildings.
- Durability of structures under climate change effects
- Evaluation of the reliability and durability of structures along the designed lifetime
- Methodologies for Performance Based Evaluation / Design of construction for progressive climate action exposures;
- Intervention strategies and adaptive building technologies

The full abstract at:

http://www.upt.ro/img/files/2013-2014/doctorat/abilitare/Dinu/Rezumat_teza_eng_Dinu.pdf

Habilitation Commission

Prof.univ.dr.ing. Adrian IOANI
Universitatea Tehnică din Cluj-Napoca;
Prof.univ.dr.ing. Ioannis VAYAS
Universitatea Națională Tehnică din Atena - GRECIA;
Prof.univ.dr.ing. Radu VĂCĂREANU
Universitatea Tehnică de Construcții din București

NEW ANALYTICAL APPROACHES TO NONLINEAR VIBRATIONS

Author: Nicolae Horațius HERIȘANU

Abstract

This habilitation thesis briefly presents the achievements of the authors in the scientific research developed after defending his PhD thesis within "Politehnica" University of Timisoara. These results are presented in 25 journal papers published in prestigious journals indexed by Science Citation Index, having significant impact factors, a monograph published by Springer Verlag – Berlin and other conference papers presented at national and international conferences as well as other journal papers.

The thesis is structured on 6 Chapters; the first 5 Chapters present the achievements of the authors in the last years and the last Chapter presents some evolution and development plans.

The main research direction on which this thesis is built-up is based on the study of nonlinear vibration using original analytical methods, which have been published in the literature by the author and his collaborators in the last decade.

After a brief introductory Chapter, the next 4 Chapters are intended to present the 4 original analytical methods proposed by the author in the literature: the Optimal Homotopy Asymptotic Method (OHAM), the Optimal Variational Iteration Method (OVIM), the Optimal Homotopy Perturbation Method (OHPM) and the Optimal Iteration Perturbation Method (OIPM).

All these original methods published in the literature by the author of the thesis and his collaborator Vasile Marinca after a close and fruitful collaboration, have a common idea, allowing obtaining solutions to problems related to nonlinear dynamical systems from mechanical engineering in an optimal approach. The analytical solutions depend on several initially unknown parameters, called "convergence-control parameters" whose optimal values are determined through a rigorous algorithm intended to minimize the residual obtained after replacing the analytical solution in the initial equation, so that the solutions converge to the exact ones with a remarkable rapidity.



The key of the problem which ensure the success of these methods consist in the determination of the optimal values of convergence-control parameters, which task can be accomplished in various ways, using some approaches such as the least square method, the collocation method, the Galerkin method, and so on, which are implemented using a computer and specific programs. Finally, the last Chapter of the thesis is intended to identify some opportunities concerning possible development of researches and a continuation of increasing the performances of the proposed methods so that these methods would become mature ones, applicable with less computational efforts and largely accessible for anyone. There is identified significant opportunities to obtain new results by enlarging the research team which will involve future PhD students which will be enrolled.

The full abstract at:

<http://www.upt.ro/img/files/2014-2015/doctorat/abilitare/herisanu/Abstract.pdf>

Habilitation Commission

Prof.univ.dr.ing. Polidor BRATU
Universitatea "Dunărea de Jos" din Galați;
Prof.univ.dr.ing. Veturia CHIROIU
Academia Română;
Prof.univ.dr.ing. Livija CVETICANIN
University of Novi Sad, Serbia

INTELLIGENT MONITORING SYSTEMS ACHIEVEMENT APPLIED IN POWER SYSTEMS

Author: Doru VĂȚĂU

Abstract

In the frame of the habilitation thesis are presented the most important personal achievements on scientific, professional and academical plan that I've obtained in the period of time January 1997 – June 2014. This period follows to my public presentation of the PhD thesis that took place on January 17th, 1997 (later confirmed by the Order of the Ministry of Education No. 3991 from June 2nd, 1997).

The habilitation thesis is structured in three parts: the abstract, the technical presentation and the bibliographic references.

The habilitation thesis starts with an abstract that includes the synthesis of the habilitation thesis. The second part of the thesis, named „Technical Presentation” includes five sections. In the first section are presented briefly the remarkable achievements obtained through research and educational activities (list with publications and grants classified on three research directions, new disciplines introduced in the education plans, taught courses, contributions brought to the development of the syllabus, invited professor, practice activities with students, conducting license and dissertation theses, endowed laboratories and library, international cooperation, management activities, etc.). The second section presents the contributions adequate to the first research direction

“Systems for monitoring and analysis of the technical status of the materials, electrical machines and electrical equipment used in power systems”. The third section makes reference to the contributions obtained in the second research direction „Power quality monitoring equipment designed for the connection points between the transmission and distribution network”. The fourth section presents the contributions from the third research direction „Power generation, transmission and delivery environment impact monitoring systems”.

The last section presents the evolution and development plan regarding the professional, scientific and academic career, as well as exact methods of putting them into practice.



The conceived action plan includes three directions of research/teaching / practical applications that are: renewable energy sources; materials, equipments, methods and work techniques under high voltage; the impact of electrical installations on the environment.

The full abstract at:

http://www.upt.ro/img/files/2014-2015/doctorat/abilitare/vatau/Teza_abilitare1_en_Vatau_Doru.pdf

Habilitation Commission

Prof. univ. dr. ing. Adrian Alexandru BADEA
Universitatea Politehnică din București
Prof.univ.em.dr.ing. Mircea EREMIA
Universitatea Politehnică din București
Prof.univ.dr.ing. Dumitru Marcel ISTRATE –
Universitatea Tehnică “Gh. Asachi” din Iași

FIRE DESIGN OF CIVIL ENGINEERING STRUCTURES

Author: Raul Dan ZAHARIA

Abstract

The thesis summarizes a part of the research activity of the candidate after defending the PhD Thesis at the Politehnica University of Timisoara in February 2000. The selected activity was considered to be relevant in terms of originality and importance, in order to anticipate an independent development of the further research and teaching career. The presentation of the post-doctoral activity is developed within the main thematic direction: "Fire design of civil engineering structures". A secondary direction is also considered: "Design assisted by testing".

The candidate was involved in the main topic "Fire design of civil engineering structures" since 2000, after the defense of the PhD thesis, when he obtained a research grant of one year, offered by the Services for Scientific and Cultural Affairs of the prime Minister of Belgium. The research was lead by Prof. Jean Marc Franssen from Liege University in Belgium, a world-wide recognized pioneer in the field of the fire design of civil engineering structures, with decisive contributions in the relatively recent topic of calculation of the fire resistance of structures. The research was focused on the fire behaviour of high-rise steel rack structures and a description of the main results of the research is presented in Part B section 2.5.1 "Fire resistance analysis of high-rise rack structures".

The relevance of the scientific activity and the recognition of the national and international activity in the field of the first main direction "Fire design of civil engineering structures" is emphasized by the publications of the candidate, mostly in cooperation with European researchers, but also by the involvement in two European technical committees. Another relevant aspect for the recognition of the international activity of the candidate in the field is that he was member of the Scientific Committees for the recent editions of the only two specialised international conferences dedicated exclusively to the structural analysis component of the fire engineering.

The implementation of the fire design principles is still an on-going process in Romania.



However, in the last decade, the candidate calculated the fire resistance of the structural elements for some structures built in Romania. This was a premiere in Romania and, up to this moment, no other similar design cases exist.

The full abstract at:

http://www.upt.ro/administrare/dgac1/file/2013-2014/abilitare/Raul_Zaharia/Abstract-Raul_ZAHARIA_en.pdf

Habilitation Commission

Prof.univ.dr.ing. Nicolae ȚĂRANU
Universitatea Tehnică "Gheorghe Asachi" din Iași;
Prof.univ.dr.ing. Adrian IOANI
Universitatea Tehnică din Cluj;
Prof.univ.dr.ing. Jean Marc FRANSSSEN
Universitatea din Liege, Belgia

MONETARY POLICY, FINANCIAL STABILITY AND ASSET PRICES

Author: Claudiu Tiberiu ALBULESCU

Abstract

The present habilitation thesis includes two main sections, namely the part covering the scientific contributions and the career development plan. The first section highlights the candidate's contributions in the field of monetary policy, financial stability and asset prices since the completion of the PhD program up to present, while the second part covers the candidate's projects for his academic activity, including future research directions.

The first part of the thesis summarizes our main scientific contributions in the field of monetary policy, financial stability and asset prices, in the context of the European economic and financial integration. Our scientific contributions are grouped considering three related directions: the link between the monetary policy and the systemic financial stability, the exchange rate stability and the relationship between the integration process, the stability and the financial volatility.

In the field of monetary policy and financial stability, the main contributions is represented by the construction of an aggregate financial instability index Albulescu (2010) and the way in which the European Central Bank considered the financial instability in its monetary policy decisions (Albulescu, 2012; Albulescu, 2013; Albulescu et al., 2013), in an augmented Taylor rule framework.

In the field of the exchange rate stability, we report two main contributions. The first is focused on the assessment of the equilibrium exchange rate determinants for the Central and Eastern European countries (Albulescu and Goyeau, 2011a). To this end, we use a panel data analysis and a behavioral model and discover that, for the analyzed period, in Latvia and Romania, the nominal exchange rate seems to be undervalued in comparison with the equilibrium exchange rate. The second contribution in this area is the assessment of the impact of movements in international oil prices, on the real exchange equilibrium rate in Romania, using a wavelet framework. We identify several periods of influence, at different frequencies, between the oil price and the exchange rate. Moreover, we prove that positive shocks have a more powerful impact on the exchange rate movements in the short run.

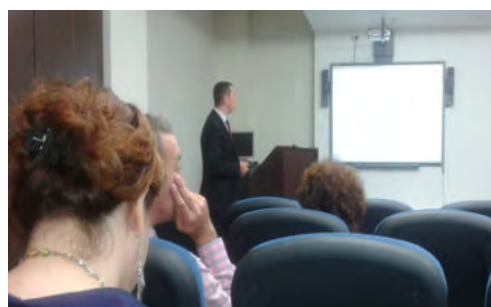

Finally, in the field of integration, financial stability and financial volatility, we show on the one hand that the financial stability plays an important role in promoting the economic and financial integration and the foreign direct investments inflows (Albulescu et al., 2010; Albulescu, 2011). Regarding the bidirectional causality between the equity index derivatives and the volatility of their underlying assets, Albulescu and Goyeau (2011b) use a vector auto-regression model and Granger causality tests and show that there is no clear evidence regarding this bidirectional causality, while Albulescu and Tiwari (2013) document several asymmetric bidirectional relationships.

The full abstract at:

<http://www.uvt.ro/en/educatie/studii-universitare-de-doctorat/ordine-privind-acordarea-titlului-de-doctor/abilitare-albulescu/>

Habilitation Commission

Prof.univ.dr. Marilen PIRTEA
Universitatea de Vest din Timișoara
Prof.univ.dr. Bogdan DIMA
Universitatea de Vest din Timișoara
Prof.univ.dr. Mihai MUTAȘCU
Universitatea de Vest din Timișoara

PhD Theses

Industrial Engineering

Marius CĂLIMANU Supervisor prof. T. Fleșer	<i>Studii privind îmbinarea nedemontabilă a materialelor compozite cu matrice de aluminiu</i> (Studies regarding the joining of aluminium metal matrix composite)
Gabriel DAMACUS Supervisor prof. D. Țucu	<i>Cercetări privind optimizarea sistemelor de ambalare pentru alimente în cazul folosirii maselor plastice</i> (Research on optimization of packaging for food when using plastic)
Mircea Adrian DUNGAN Supervisor prof. D. Țucu	<i>Soluții constructive și tehnologice pentru optimizarea sistemelor de frânare ale materialului rulant</i> (Constructive and technological solutions to optimize braking systems of railway rolling stock)
Stelian Cornel FLORICA Supervisor prof. G. Drăghici	<i>Contribuții privind concepția colaborativă a produsului în platforme PLM distribuite</i> (Contributions to collaborative product design in distributed PLM platform)
Ionela Ramona GUȘETOIU Supervisor prof. D. Țucu	<i>Aspecte privind diagnoza și evaluarea relațiilor de muncă în cadrul proceselor tehnologice</i> (Aspects concerning diagnosis and evaluation of labor relations within technological processes)
Anca IANCU Supervisor prof. D. Țucu	<i>Contribuții la optimizarea calității în sistemele tehnologice pentru fabricarea pastelor fără gluten</i> (Contributions to optimize quality in technological systems for making gluten free pasta)
Octavian Victor OANCĂ Supervisors prof. I. Bordeășu Supervisors prof. I. Mitelea	<i>Tehnici de optimizare a rezistenței la eroziunea prin cavitație a unor aliaje CuAlNiFeMn destinate execuției elicelor navale</i> (Optimization techniques of the resistance to erosion by cavitation for alloys CuNiFeAlMn destined of the marine propellers execution)
Alexandru-Silviu SMARANDA Supervisor prof. D. Țucu	<i>Analiza tehnologicității industriale a materialelor plastice compozite din resurse regenerabile</i> (Analysys of the industrial manufacturability of plastic material composites from renewable resources)

Mechanical Engineering

Flavia BĂLĂNEAN Supervisor prof. M. TOTH-TAȘCĂU	<i>Studii și cercetări privind implanturile pentru articulația cotului</i> (Research and studies on elbow implants)
Ion Silviu BOROZAN Supervisor prof. I. Maniu	<i>Determinarea parametrilor cutiilor de viteze automate în scopul îmbunătățirii caracteristicilor tehnico-funcționale ale acestora</i> (Automatic gearboxes parametric quality analysis regarding the improvement of the technical and functional characteristics)
Tiberiu CIOCAN Supervisor prof. R. Susan-Resiga	<i>Optimizarea curgerii cu rotație la intrarea în tubul de aspirație al turbinelor hidraulice</i> (Optimization of the swirling flow at the draft tube inlet of hydraulic turbines)
Remus-Daniel ENE Supervisor prof. L. Bereteu	<i>Studii și cercetări în mecanica mediilor continue prin aplicarea unor noi metode analitice aproximative</i> (Studies and researchers in continuum mechanics by applying new approximate analytical methods)

Cristina FLOREA
Supervisors
prof. A. DAVIDESCU
prof. R. KORHONEN

Caracterizarea proprietăților de material ale cartilajului articular, condrocitelor și a osului prin tehnici la scară nano și micro
(Characterization of articular cartilage, chondrocyte and bone properties using nano and microscale techniques)

Nina GORIE
Supervisor prof. V. Dolga

Contribuții la studiul unui sistem mecatronic pentru recuperarea persoanelor cu dizabilități
(Contributions to the study of a mechatronic system for recovery of persons with disabilities)

Tiberiu Adrian MEDGYESI
Supervisor: prof. L. Bereteu

Contribuții la dezvoltarea unor metode vibro-acustice pentru determinarea unor caracteristici mecanice ale structurilor sudate din plăci subțiri
(Contributions to the development of vibroacoustic methods for determining the mechanical properties of thin plate welded structures)

Alina MONDOC
Supervisor: prof. V. Dolga

Analiza teoretică și experimentală a aspectelor aleatorii din scena de lucru a unui robot mobil
(A theoretical and experimental approach of aleatory aspects in the workspace of a mobile robot)

Ioan NEAMȚ
Supervisor: prof. I. Ionel

Cercetări teoretice și experimentale privind posibilitatea valorificării energetice a nămolului din stațiile de epurare municipală
(Theoretical and experimental research concerning the possibilities of energy recovery using the sewage sludge from municipal waste water treatment plants)

Nicolai PAȘCA
Supervisor prof. L. Marșavina

Evaluarea durabilității componentelor hidroagregatelor
(Durability assessment for hydropower components)

Oana Maria PAȘCA
Supervisor prof. M. TOTH-TAȘCĂU

Studii și cercetări privind ortezele de gleznă și picior
(Research and studies regarding ankle and foot orthosis)

Cristian TOADER-PASTI
Supervisor: prof. L. Bereteu

Cercetări privind dezvoltarea sistemelor de testare ale protezelor de gleznă
(Researches regarding the development of the systems used in ankle prosthesis testing)

Maria Silvia PERNEVAN
Supervisor prof. L. Marșavina

Caracterizarea mecanică a materialelor compozite ranforsate cu fibre și puzderii liberiene
(Mechanical characterization of composite materials reinforced with bast shives and bast fibers)

Mariana-Claudia VOICU
Supervisor prof. I. Maniu

Optimizarea comportamentului dinamic al sistemelor de imprimare
(Optimization of dynamic behaviour of printing roller systems)

Chemical Engineering

Radu Ovidiu ARDELEAN
Supervisor prof. C. M. Davidescu

Noi tipuri de materiale avansate obținute prin modificarea chimică a unor matrici polimerice și evaluarea performanțelor lor în calitate de adsorbanti
(New types of advanced materials obtained by chemical modification of polymer matrices and their performance evaluation as adsorbents)

Marian BOBINĂ
Supervisor prof. N. Vaszilcsin

Utilizarea produsilor naturali ca inhibitori de coroziune pentru metale și aliaje
(The use of natural products as corrosion inhibitors for metals and alloys)

Mircea Laurențiu DAN Supervisor prof. N. Vaszilcsin	<i>Comportarea electrochimică a perovskiților cobaltului cu structură stratificată de tip 112 și 114</i> (The electrochemical behavior of cobalt perovskite - type layered structure 112 and 114)
Ionița Firuța FIȚIGĂU Supervisor prof. F Peter	<i>Modificarea enzimatică a ligninei și a fracțiunilor de lignină obținute în urma pretratamentului biomasei lignocelulozice</i> (Enzymatic modification of lignin and lignin fractions obtained by pretreatment of lignocellulosic biomass)
Maria ILICI Supervisor: prof. M. Ștefănescu	<i>Sinteza, caracterizarea fizico-chimică, structurală și potențialul coordinativ al unor noi compuși heterociclici din clasa 1,3,4-tiadiazolului</i> (Synthesis, physico-chemical, structural characterization and coordinative potential of new heterocyclic compounds from 1,3,4-thiadiazole class)
Georgeta MIHOC Supervisor prof. C. Păcurariu	<i>Materiale avansate utilizate ca adsorbantți pentru eliminarea unor poluanți din ape reziduale</i> (Advanced materials used as adsorbents for the removal of pollutants from wastewater)
Oana Ramona Maria PAȘKA Supervisor prof. C. Păcurariu	<i>Contribuții privind adsorbția unor coloranți din ape reziduale</i> (Contribution to the adsorption of synthetic dyes from wastewaters)
Iulia Maria PĂUȘESCU Supervisor: prof. M. Ștefănescu Supervisor: prof. F. Peter	<i>Studii privind aromaticitatea unor combinații heterociclice</i> (Studies on the aromaticity of some heterocyclic compounds)
Elena Alina TĂCULESCU Supervisor prof. C. Păcurariu	<i>Noi abordări privind sinteza și utilizarea unor nanomateriale cu proprietăți magnetice</i> (New approaches regarding the synthesis and the use of some nanomaterials with magnetic properties)

Materials Engineering

Iuliana BADEA Supervisor prof. I. Grozescu	<i>Studiul obținerii materialelor termoelectrice pe bază de Bi₂Te₃. Caracterizarea și testarea proprietăților termoelectrice</i> (The study of thermoelectric materials obtained based on Bi ₂ Te ₃ . Characterization and testing of thermoelectric properties)
Victoria HARANGUȘ Supervisor prof. T. Hepuț	<i>Contribuții privind creșterea gradului de siguranță și securitate în muncă la oțelăriile electrice</i> (Contributions to increasing the level of occupational safety and security in the electric steelworks)
Georgiana MELCIOIU Supervisor prof. V.A. Șerban	<i>Studii și cercetări privind limitarea apariției și dezvoltării excrescențelor de tip whiskers la aliajele de lipire pe bază de staniu</i> (Studies and researches to mitigate occurrence and development the growths whiskers at the tin-based soldering alloys)
Daniel OCHIAN Supervisor prof. I. Mitelea	<i>Contribuții privind procesul de sudare a oțelurilor aliate destinate execuției pânelor de ferăstrău</i> (Contributions on the welding process of alloyed steels for saw blades)
Adina PĂUCĂ Supervisor prof. T. Hepuț	<i>Cercetări privind îmbunătățirea caracteristicilor cilindrilor de laminor și comportarea acestora în exploatare</i> (Research on improving the characteristics of rolling cylinders and their behavior in service)

Florina Ștefania RUS Supervisor prof. I. Grozescu	<i>Nanomateriale oxidice de tipul AB2O4 cu aplicații în senzorială</i> (AB2O4 type oxide Nanomaterials with applications in sensors)
Cristian STOIAN Supervisor prof. V. A. Șerban	<i>Dezvoltarea aliajelor de brazare amorfe pe bază de cupru utilizate pentru îmbinări Cu-Cu/Inox</i> (Development of amorphous brazing alloys of copper user for joints Cu-Cu/Inox)
Maria Laura STRUGARIU Supervisor prof. T. Hepuț	<i>Cercetări privind valorificarea subproduselor rezultate de la epurarea apelor industriale</i> (Research on the recovery of by-products from industrial wastewaters)
Adela Susana TODORUȚ Supervisor prof. T. Hepuț	<i>Cercetări privind gestionarea și valorificarea deșeurilor mărunte și pulverulente, rezultate din industria de materiale, în contextul dezvoltării durabile a județului Hunedoara</i> (Management research and recovery of small and powdery wastes, resulted from materials industry, for sustainable development of Hunedoara area)

Electronics and Telecommunication Engineering

Florentina Anica BOTEZATU Supervisor prof. C. I. Toma	<i>Contribuții la evaluarea asistată de calculator a testelor psihologice folosind tehnici de prelucrare a imaginilor</i> (Contributions to the computer-assisted assessment of psychological tests using image-processing techniques)
Aurel CIREȘAN Supervisor prof. D. Lascu	<i>Convertoare CUK de generația a doua</i> (Second generation CUK converters)
Eugen-Victor CUTEANU Supervisor prof. A. Isar	<i>Metode de reducere a PAPR în sistemele de comunicații bazate pe OFDM</i> (PAPR reduction methods in OFDM based Communication systems)
Vasile-Daniel DRĂGHICI Supervisor prof. D. Lascu	<i>Comenzi digitale predictive în curent pentru convertoare dc-dc în comutație</i> (Predictive digital current-mode control in switching dc-dc converters)
Andrei Marius GABOR Supervisor prof. R. Vasiu	<i>Baze de date multimedia</i> (Multimedia databases)
Lucian MORGOȘ Supervisor prof. M. Naforniță	<i>Contribuții privind îmbunătățirea tehnicilor de egalizare ale canalelor radio</i> (Radio Channels equalization techniques improvement)
Dan Mihai MIHĂILESCU Supervisor prof. C. I. Toma	<i>Contribuții la diagnosticul asistat de calculator în imaginile de ultrasonografie abdominală</i> (Contributions to computer-aided diagnosis in abdominal ultrasound imagery)
Alexandru Sorin PEȚAN Supervisor prof. R. Vasiu	<i>Sisteme multimedia interactive adaptive cu aplicații în e-learning, divertisment și formare profesională</i> (Interactive adaptive multimedia systems applied in e-learning, entertainment and professional development)
Mihai POMARLAN Supervisor prof. V. Tîpouț	<i>Planificatoare de mișcare pentru multiple interogări bazate pe hărți compacte pentru medii dinamice și dificile</i> (Multi-query motion planners based on sparse roadmaps for changing and difficult environments)

Florin VANCEA
Supervisor prof. I. Naforniță

Detecția atacurilor informatice și a anomaliilor din rețele de calculatoare prin supravegherea caracteristicilor de trafic folosind tehnici de prelucrare a semnalelor
(Detection of security attacks and of other anomalies in computer networks by monitoring traffic characteristics using signal processing methods)

Gheza Gavril DOHI TREPSZKER
Supervisor prof. C. I. Toma

Tehnici de supraveghere video a râurilor
(Video surveillance techniques for rivers monitoring)

Lavinia ȚEPELEA
Supervisor prof. V. Tîponuț

Noi metode pentru deplasarea asistată în medii cu obstacole a persoanelor cu deficiențe de vedere
(New methods for assisted movement in obstacle environments for visual impairments)

Power Engineering

Mihaela FRIGURĂ-ILIASA
Supervisor prof. P. Andrea

Contribuții privind îmbunătățirea performanțelor funcționale ale varistoarelor pe bază de oxizi metalici
(Contributions concerning the functional performance improvement for metal oxide based varistors)

Monica Mirela MOLNAR-MATEI
Supervisor prof. F. D. Șurianu

Metodă fuzzy-clustering de clasificare a golurilor de tensiune trifazate din rețeaua electrică
(Fuzzy-clustering method for three phase voltage dips classification from electrical network)

Ioan Sorin RANCOV
Supervisor prof. P. Andrea

Cercetări privind creșterea randamentului instalațiilor electrice fotovoltaice
(Researches about increasing the efficiency of photovoltaic electrical installations)

Attila SIMO
Supervisor prof. Ș. Kilyeni

Planificarea dinamică a extinderii rețelelor de transport al energiei electrice utilizând tehnici de inteligență artificială
(Artificial intelligence based transmission network dynamic expansion planning)

Răzvan Petru TESLOVAN
Supervisor prof. Ș. Kilyeni

Planificarea extinderii rețelelor electrice de distribuție
(Distribution network expansion planning)

Computers and Information Technology

Kristian BEREȘ
Supervisor prof. N. Robu

Model de învățare amestecat cu "Managerul de clasă Virtuală", ca un factor în eficiența sistemului de educație în situații obișnuite și de urgență
(Blended learning model with Virtual Classroom Manager as a factor in efficiency of education system in ordinary and emergency situations)

Adela Diana BERDIE
Supervisor prof. O. Proștean

Contribuții privind evaluarea multicriterială a tehnologiilor SAP
(Contributions regarding the multicriteria evaluation of the SAP technologies)

Daniel DRAGU Supervisor prof. V. Stoicu-Tivadar	<i>Contribuții privind integrarea cunoașterii medicale utilizând standardul Topic Maps</i> (Contributions on medical knowledge integration using Topic Maps standard)
Iulia Maria HARAGOȘ Supervisor prof. Ș. Holban	<i>Contribuții la modelarea analitică a traficului rutier cu elemente din teoria șirurilor de așteptare</i> (Contributions on analytical modeling of road traffic with elements of queuing theory)
Valentin Mircea LUPEA Supervisor prof. Ș. Holban	<i>Contribuții la creșterea eficienței neuronului cu ponderi numere complexe și funcție periodică de activare</i> (Contributions to efficiency improvement of multi-valued neurons with a periodic activation function)
Elisa Valentina ONETJ (MOISI) Supervisor prof. V. I. Crețu	<i>Reconstrucția imaginilor binare în cadrul tomografiei discrete folosind rețeaua de celule triunghiulare</i> (Binary images reconstruction for discrete tomography using triangular grid)
Vasile TOPAC Supervisor prof. V. Stoicu-Tivadar	<i>Îmbunătățirea accesibilității textului și a înțelegerii informației de specialitate</i> (Improving text accessibility and understanding of domain-specific information)

Systems Engineering

Cristina-Elena COMAN Supervisor prof. G. D. Andreescu	<i>Strategii de conducere pentru aplicații cu mașini sincrone cu magneți permanenți</i> (Control strategies for permanent magnet synchronous motor applications)
Eugen Horațiu GURBAN Supervisor prof. G. D. Andreescu	<i>Soluții de conducere pentru climatizarea serelor</i> (Control solutions for greenhouse climate systems)
Pal-Ștefan MURVAY Supervisor prof. I. SILEA	<i>Securitate criptografică pentru magistrala de date controller area network în vehicule</i> (Cryptographic security for vehicular controller area networks)
Alexandra-Iulia STÎNEAN Supervisor prof. Ș. Preitl	<i>Contribuții la dezvoltarea unor soluții de reglare dedicate sistemelor de acționare electrică cu parametri variabili și cu intrări variabile în timp</i> (Contributions to the development of control solutions for electrical drive systems with variable parameters and variable references)

Electrical Engineering

Ioan Cristian ABRUDEAN Supervisor prof. I. Șora	<i>Cercetări privind echipamente și procese electrotermice performante în câmp de microunde</i> (Research on efficient electrothermal equipments and processes in microwave field)
Mircea BABA Supervisor prof. I. Boldea	<i>Convertoare Z cu PWM cu 4 elemente de comutație în acționări cu motoare de inducție</i> (4 Switch Z PWM convertes in induction motor drives)
Ovidiu Roman PELAN Supervisor prof. N. Muntean	<i>Convertoare DC-DC hibride pentru sisteme automotiv și energii regenerabile</i> (Hybrid DC-DC converters for autotomotive and renewable energies systems)
Dragoș URSU Supervisor prof. I. Boldea	<i>Mașini multifazate reactive fără perii în acționări electrice</i> (Brushless DC multiphase reluctance machines and drives)

Civil Engineering

Marius ADAM Supervisor prof. I. SÂRBU	<i>Optimizarea instalațiilor de ventilare/climatizare în regim de răcire în scopul asigurării eficienței energetice și a confortului în clădiri de birouri</i> (Optimization of the air conditioning systems in cooling mode to ensure energy efficiency and comfort in office buildings)
Iulian Zoltan BOBOESCU Supervisor prof. I. Mirel	<i>Tehnologii bioenergetice pentru epurarea apelor reziduale</i> (Bioenergetic technologies developed for wastewater treatment processes)
Alexandru BOTICI Supervisor prof. D. Dubină	<i>Studiul soluțiilor de reabilitare pentru clădiri de locuit din panouri mari prefabricate din beton armat</i> (Studies on rehabilitation systems of residential collective buildings built with large precast concrete panels)
Felicia NICULESCU-ENACHE Supervisor prof. M. Marin	<i>Contribuții la studiul folosirii materialelor geosintetice pentru realizarea sistemelor de fundare a construcțiilor supuse la solicitări statice și dinamice</i> (Contributions to the study using for systems geosynthetics building foundations subjected to static and dynamic loads)
Monica ISACU Supervisor prof. I. Mirel	<i>Contribuții cu privire la eficientizarea stațiilor de epurare orășenești</i> (Contributions on improving the efficiency of urban wastewater treatment plants)
Marius HÂRȚA Supervisor prof. V. Stoian	<i>Impactul structurilor metalice în arhitectura modernă – reflecții asupra procesului de preluare și punere în valoare a potențialului structurilor metalice în arhitectură</i> (The impact of metal load bearing structures in architecture - reflections on the process of assimilation and harnessing of the potentialities of metal load bearing structures in architecture)
Paul MOLNAR Supervisor prof. T.E. Man	<i>Lucrari hidrotehnice pentru asigurarea continuitatii ecohidraulice a raurilor interioare si a fluviului Dunarea</i> (Structures for the restoration of longitudinal continuity of the Danube and inland rivers)
Florin-Cătălin MIRON Supervisor prof. M. Marin	<i>Soluții de consolidare a clădirilor degradate în timp din cauze diverse</i> (Consolidation measures for buldings which suffered time degradation by reason of multiple causes)
Corina Mihaela PANFIL Supervisor prof. I. Mirel	<i>Studiul sistemelor alternative de canalizare a apelor uzate din centrele populate</i> (A study of alternative sewage systems for wastewater in populated areas)
Ramona-Maria RUSU Supervisor prof. G. Crețu	<i>Cercetări privind impactul urbanizării asupra scurgerilor hidrologice</i> (Study regarding the impact of urbanization on storm water runoff)
Izabella Ștefania SZIGYARTO Supervisor prof. I. Mirel	<i>Considerații cu privire la implementarea sistemelor vacuumate de canalizare-Studii de caz Comuna Bors, județul Bihor, Comuna Pericei, județul Sălaj</i> (Considerations regarding the implementation of vacuum sewerage systems - Case studies village Bors, Bihor County, village Pericei, Salaj County)
Mirela-Adriana SZITAR Supervisor prof. D. M. Grecea	<i>Locuința colectivă versus locuința individuală urbană prin prisma dezvoltării durabile în Câmpia Banatului</i> (Collective dwellings versus individual urban housing through sustainable development perspective in Banat plain)

Octavian STANA Supervisor prof. T.E. Man	<i>Dezvoltarea rurală durabilă a infrastructurii unei localități rurale. Studiu de caz: localitatea Periam, județul Timiș</i> (Sustainable rural development of rural infrastructure, case study: Periam locality, Timis county)
Raluca VĂDUVA Supervisor prof. I. David	<i>Planificarea integrată a teritoriului în condiții de incertitudine a riscului la inundații</i> (Integrated spatial planning in the context of flood)
Clara - Beatrice VÎLCEANU Supervisor prof. M. Marin	<i>Utilizarea tehnologiilor geodezice moderne pentru monitorizarea, prelucrarea și analiza unor alunecări de teren și construcții din pământ armat</i> (Monitoring, modeling and analysis of landslides and reinforced-earth constructions using modern geodetic technologies)

Engineering and Management

Adrian ADAM Supervisor prof. G. Proștean	<i>Contribuții privind transferul cunoașterii în managementul proiectelor de implementare a sistemelor ERP</i> (Contributions regarding the knowledge transfer in the project management of ERP systems implementation)
Olga-Ioana AMARIEI Supervisor prof. C. D. Dumitrescu	<i>Contribuții privind modelarea, simularea și optimizarea fluxurilor de producție utilizând programe dedicate</i> (Contributions regarding modelling, simulation and optimisation of manufacturing flows using dedicated software programs)
Ana-Maria BRANEA Supervisor prof. M. Izvercian	<i>Contribuții la managementul urban aplicat pentru guvernarea comunităților</i> (Contributions to urban management applied for community governance)
Cella Flavia BUCIUMAN Supervisor prof. M. Petrea Izvercian	<i>Contribuții privind modelarea sistemelor de marketing</i> (Contributions regarding marketing systems modelling)
Sabin-Ioan IRIMIE Supervisor prof. C. D. Dumitrescu	<i>Managementul dezvoltării durabile al unui sistem energetic comunitar - cu referire la Valea Jiului</i> (The management of sustainable development of a community energy system - with reference to Jiu Valley)
Dorina-Alina RADU Supervisor prof. M. Izvercian	<i>Contribuții privind competitivitatea resursei umane</i> (Contributions on human resources competitiveness)
Patrick ȘTEFĂNESCU Supervisor prof. M. Mocan	<i>Contribuții la eficientizarea transportului public de persoane în mediul urban și periurban, aferent Municipiului Timișoara</i> (Contributions to public transport efficiency in urban and peri-urban environment, afferent to Timisoara Municipality)
Nicoleta MĂNESCU TRANDAFIR Supervisor prof. C. D. Dumitrescu	<i>Studiu privind sustenabilitatea proceselor specifice industriei pielărie</i> (Study the sustainability of the specific processes from the leather industry)

Scientific Conferences

Scientific Conferences held in 2014

SACI 2014

IEEE 9th International Symposium on Applied Computational Intelligence and Informatics SACI 2014
15-17 May 2014, Timișoara

Organizer: Politehnica University of Timisoara, Faculty of Automation and Computers, and Óbuda University, Hungary

<http://conf.uni-obuda.hu/saci2014/>

- SACI 2014 conference focuses on theory and application on the field of applied computational intelligence and informatics.
- The aim is to provide platform for scientists, teachers, researchers and students as well to publish their papers, and discuss the results.
SACI conference appears on the AUSTRALIAN RESEARCH COUNCIL list, in class C.



15th International Conference Polymers and Organic Chemistry 2014

10-13 June 2014, Timișoara

Organizer: Faculty of Industrial Chemistry and Environmental Engineering

http://www.poc2014.upt.ro/Information_conference-program_38.html

- The main goal of POC 2014 Conference was to share the most recent information between scientists dealing with synthesis and application of polymers. POC 2014 was a successful scientific events attend by over 100 registred patrticipants from 28 countries. The conference presentationes focused on six topics: Advances in polymer synthesis, Novel functional polymers, Polymers for catalysis and energy applications, Biocatalysis in polymer synthesis, Polymers for separations and environmental protection, Polymers in medicine, biochemistry and agriculture.
- The conference was organized under the sponsorship of IUPAC - The International Union of Pure and Applied Chemistry.

CEM 2014

The 9th International Workshop on Electromagnetic Compatibility CEM 2014

3-5 September 2014, Timișoara

Organizer: Politehnica University of Timisoara, National Institute for R&D in Electrical Engineering ICPE-CA

http://www.icpe-ca.ro/ro/cem2014_449

- The workshop was a good resean for the dissemination and promoting of the Romanian and foreign scientific researches results, knowledge of the newest achievements in electromagnetic compatibility in the domanins electronics, communications systems, industrial systems; biocompatibility; human exposition effects to the electromagnetic fields, electromagnetic non-distructive evaluation, standardization issues.
- The paper was published in the Journal Advanced in Electrical and Computer Engineering, accepted in ISI Thomson database.



International Conference Social Media in Academia: Research and Teaching SMART 2014

18–21 September 2014, Timișoara

Organizer: Politehnica University of Timișoara, West University of Timișoara, EduSoft Bacau

<http://www.edusoft.ro/smart2014/index.php#.VDTMxBidLct>

- Social Media in Academia: Research and Teaching provides relevant theoretical frameworks and the latest research on social media the challenges in the educational and political context. Our conference is essential for professionals aiming to improve their understanding of social media at different levels of education and civic/social/political engagement as well as researchers in the fields of e-learning, educational science, political science, new media, and information and communication sciences and much more.
- The proceedings of the conference published by Medimond – Monduzzi Editore, Bologna, Italy, It will be indexed by Thomson Reuters (Conference Proceedings Citation Index).



International Conference on Applied Sciences ICAS2014

2–4 October 2014, Hunedoara

Organizer: Politehnica University of Timișoara, Military Economics Academy of Wuhan

<http://www.fih.upt.ro/v3/ICAS2014/index.htm>

The topics of the conference covered a comprehensive spectrum of issues:

- Economical Sciences, Engineering Sciences, Fundamental Sciences, Medical Sciences

The conference proceedings or in supporting journals, was indexed in recognized International Data Bases:

- The Annals of Faculty of Engineering Hunedoara
- Acta Technica Corviniensis
- Review of the Air Force Academy
- EcoTerra



The 3rd Conference „Microactuators and Micromechanisms” MAMM 2014

2–4 October 2014, Timișoara

Organizer: Mechatronics Department, Politehnica University of Timișoara

<http://mamm-2014.mec.upt.ro/>

- The aim of the conference is to bring together researchers, scientists, industry experts and students to provide, within a collegial and stimulating environment, the opportunity for know-how exchange and build up collaboration in various disciplines referring to micro systems technology. The paper was published in a book edited by Springer MMS Series.
- TOPICS OF INTEREST FOR THE CONFERENCE: Microactuators and micro-assembly, Micro sensors involving movable solids, Micro-opto-mechanical device, Mechanical tools for cell and tissue studies, Micromanipulation and micro-stages, Micro-scale flight and swimming, Micro-robotics and surgical tools, Micron-scale power generation, Miniature manufacturing machines, Micromechatronics and micro-mechanisms., Biomechanics micro and nano scales, Control issues in microsystems.



Regional South East European Conference 2014 (RSEEC 2014) - Innovation for efficient and effective management, solutions for power systems of the future!

8-10 October 2014, Timișoara

Organizer: Politehnica University of Timișoara, CIGRÉ's Romanian National Committee, CNTEE Transelectrica (the Romanian TSO) and ALSTR (the Romanian technical authority in the field of Live Maintenance),

<http://www.rseec2014.org/>

- The conference brings together power systems engineers, decision makers, economists, academics and others with interest in the domain. The conference also promotes CIGRÉ as a strong technical organization, capable of contributing to the technical expertise and know-how through its study committees, conference proceedings and the technical documents.
- Main Topics was: Electrical networks of the future, State of the Technology and Future Trends, Power system solutions for renewable sources (RES), Challenges in education of power system workforce, Live working.



The 12th edition of the IEEE International Symposium on RObotic and SEnsors Environments ROSE 2014

16-18 October 2014, Timișoara

Organizer: Politehnica University of Timișoara, Department of Computer Science

<http://rose2014.ieee-ims.org/content/organizers>

- ROSE is a high level scientific conference, organized annually by the IEEE Instrumentation and Measurement Society, USA. It is attended by top international experts and has a large visibility in the field. Previous editions of ROSE have been held in Canada, USA and in several European countries, such as Germany, Austria, Sweden and Italy.
- Celebrating its 12th edition this year, ROSE 2014 was enjoyed the presence of experts from USA, Canada, Japan, Taiwan, Germany, Italy, Austria, France, Greece, Norway and Romania, who presents significant scientific contributions and technological advances in the top fields of robotic systems and intelligent sensing environments.



International Symposium on Electronics and Telecommunications ETC 2014 Eleventh Edition

14-15 November 2014, Timișoara

Organizer: Faculty of Electronics and Telecommunications

<http://conference.etc.upt.ro/isetc2014/home.php>

- Since 1994, when the first edition of the International Symposium on Electronics and Telecommunications took place, scientific event has grown from a national happening to an important international event, organized every two years.
- The Symposium is organized by the Faculty of Electronics and Telecommunications and the Association of Electronics Engineers from Timișoara under the aegis of IEEE Romanian Section and Romanian Academy of Technical Sciences.
- Since 2010 the Symposium has become independent and the papers are published in dedicated proceedings. Papers of 2010, 2012 and 2014 editions were included in IEEE eXplore. Moreover in 2010 and 2012 proceeding is included in Thompson ISI databases, which we intend to do this year too.



INFER Workshop Monetary Policy, Asset Prices and the Real Economy in Central and Eastern Europe

12-13 December 2014, Timișoara

Organizer: INFER (International Network for Economic Research), RCEM (Research Centre for Engineering and Management), ECREB (East-European Center for Research in Economics and Business)

<http://www.ecreb.ro/?p=361>

- This workshop provided an opportunity for all those interested in monetary policy, asset prices and real economy to discuss their research and to exchange ideas.
- The purpose of the workshop is to address the Central and Eastern European (CEE) countries case, characterized by important changes in their monetary policy framework in the eve of their accession to the EMU, by the development of their financial markets and by the fluctuations of their real economy in the context of the recent financial crisis.

CEM & EMC 2014

The 8th PhD International Seminar On Computational Electromagnetics and Electromagnetic Compatibility CEM & EMC 2014

2-4 September 2014, Timișoara

Organizer: Department of Fundamental Physics for Engineers

- The PhD International Seminar On Computational Electromagnetics and Electromagnetic Compatibility started in 2004. The first edition was organized in Budva, Montenegro.
- The present 8th International Ph.D. seminar, entitled Computational Electromagnetics and Electromagnetic Compatibility is a continuity of the previous seminars. At the seminar we have participants of the Ilmenau University of Technology (Germany), Technical University of Sofia (Bulgaria), University of Nis and University of Novi Sad (Serbia), University of Skopje (Macedonia), University of Banja Luka (Bosnia and Herzegovina), University of Osijek (Croatia), and Politehnica University of Timișoara (Romania).



1st International Workshop on "Open Educational Resources and Massive Open Online Courses", co-located with the 10th eLearning and Software for Education Conference - eLSE 2014

24-25 April, Bucharest

Co-organizer: CeL and CS Department, UPT

http://www.elseconference.eu/pages/view?page=open_education_open_online_courses

- The primary goal of the workshop is to bring together educational actors or stakeholders as teachers, trainers, technologists, researchers, course designers, doctoral students in the fields of new technologies, pedagogies and policies related to Open Educational Resources (OER) and Massive Open Online Courses (MOOC) in order to share knowledge, approaches, strategies, models, solutions and applications in an educational context.
- The book of workshop is indexed by ISI Web of SCIENCE, CEEOL - Central and Eastern European Online Library, ProQuest, EBSCO HOST.



14th International Conference on OPTIMIZATION OF ELECTRICAL AND ELECTRONIC EQUIPMENT OPTIM 2014

22- 24 May 2014, Brasov

Co-organizer: Politehnica University of Timisoara, Transilvania University of Brasov, Tehnical University of Cluj-Napoca

<http://www.info-optim.ro/index.php>

- OPTIM is organized every two years in the same mountain region of Transylvania, Romania - a multiethnic region with strong medieval architecture treasures - by three major Romanian Universities totalling more than 40,000 engineering students.
- Traditionally OPTIM was (is) technically sponsored by IEEE-IAS, IEEE-PELS, IEEE-IES (USA), IEEE Romania, the Romanian Academy, the Academy of Technical Sciences in Romania, Romanian Electrotechnical Committee.
- The technical spectrum of OPTIM is similar in breadth to IEEE-IAS Meetings, though at a reduced scale, as expected.
- Presented papers were published in the conference Proceedings that is indexed by IEEE Xplore and ISI Thomson.



The 24th International Conference NOISE AND VIBRATION

29 - 31 October, 2014, Niš, Serbia,

Co-organizer: Acoustics and Vibration Laboratory, Politehnica University of Timisoara, and the University of Niš, Faculty of Occupational Safety

<http://www.znrfak.ni.ac.rs/SERBIAN/009-NAUKA/NOISE2014/Index.html>

- The main objective of this Conference is to provide an international forum with advanced scientific knowledge on noise and vibration.
- The conference is organised under the auspices of the Ministry of Education and Science of the Republic of Serbia.

Major topics of interest:

- Noise generation and propagation, Vibration control, Noise control, Environmental noise, Effect of noise and vibrations, Analysis of noise and vibration

Scientific Journals



Transactions on Automatic Control and Computer Science, Volume 59 (73), Issue 1, 2
<http://www.ac.upt.ro/journal/>

The history of this Journal of the Politehnica University of Timisoara is strongly related to its creation under the name Polytechnic School of Timisoara (Ecole Polytechnique de Timisoara). The journal is dedicated to publishing original theoretical and applicative research results and overviews on the current Research status in Automation, Computer Science and Applied Informatics.

Transactions on Automatic Control and Computer Science is indexed by: Index COPERNICUS (Journals Master List), VINITI (All-Russian Institute of Scientific and Technical Information), (CNCISIS B+ journal).



Transactions on Engineering and Management, Volume 1, Issue 1
<http://www.mpt.upt.ro/eng/research/buletin-stiintific.html>

The Scientific Bulletin of the Politehnica University of Timisoara, **Transactions on Engineering and Management** aims to present the latest thinking and scientific research on major topics:

- management;
- engineering economy.



Transactions on Hydrotehnics, Volume 59(73), Issue 1, 2
<http://www.ct.upt.ro/buletinhidro/index.htm>

The Scientific Bulletin of the Politehnica University of Timisoara, Transactions on Hydrotechnics is coordinated since 1992 by the Faculty of Hydrotechnical Engineering. Published papers in the journal focus on engineering sciences, civil engineering, theoretical and applied hydraulic, mathematics and numerical modeling, hydrology and water management, hydrotechnical developments and constructions, land improvement (irrigations, drainage, erosion control), engineering and sustainable rural development, water supply and sewerage systems, wastewater treatment, hydraulic structures and technologies.

The Journal is published entirely in English, with abstracts and keywords, with international exposure.

The revue is known for experts from home and abroad, is included in the database (Viniti, Russia) and international catalogs (SUWECO, Czech Republic). The Bulletin is broadcast in 26 foreign institutions and foreign publications received in exchange are in number of 19.

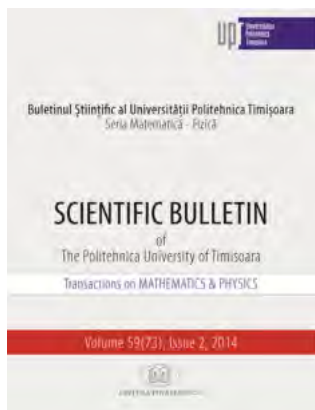

Transactions on Mathematics and Physics, Volume 59, (73) Issue 1, 2

http://www.upt.ro/cercetare/mate_fizica.php

The journal "Bulletin Scientifique de l'Ecole Polytechnique de Timisoara" was founded in 1923, when the head of the Polytechnical School of Timisoara was mathematicians Victor Vălcovici (1885-1970).

The first two issues appeared in 1925, respectively in 1926. In the first years, the journal has been contained mostly the mathematical articles (the authors being some famous national and foreign mathematicians as well V. Alaci, G. Alexich, M. Ghermănescu, D. Pompeiu, Ch. Brunold, G. Bouligand). This fact confer to actual journal "Transactions on Mathematics and Physics" of the Scientific Bulletin of "Politehnica" University of Timisoara, Romania the justification to realize the continuity of the old "Bulletin Scientifique".

The **Transactions on Mathematics and Physics** is indexed CNCIS , B+.

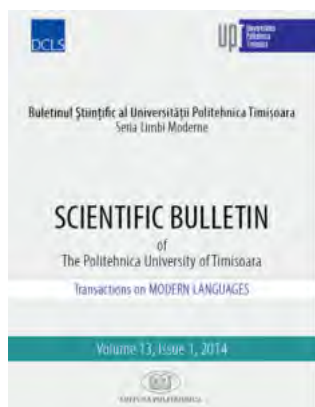

Transactions on Modern Languages, Volume13, Issue 1

<http://www.cls.upt.ro/publicatii/buletinul-stiintific/history>

The Transactions on Modern Languages, published by the Department of Communication and Foreign Languages, has its origin in The Social Sciences and Humanities Series, started in 1991 under ISSN 1223-1959.

The Transactions on Modern Languages publishes original papers in all areas of theoretical and applied linguistics: Linguistics, Translation and Interpreting Studies, Discourse Analysis, Pragmatics, Rhetoric, Terminology, LSP, Foreign Language Teaching.

The journal is included in the CEEOL, Fabula and EBSCO data bases.



Journal of Electrical Engineering, Volume 14, Edition 1, 2, 3, 4

<http://www.jee.ro/index.php>

JEE continues the prestigious "Scientific Bulletin" of the Politehnica University of Timisoara, Electrotechnical section, but in electronic form.

It also aims to become a fully international archival journal.

Its scope includes all issues of widespread generic interest to engineers who work in the field of electrical engineering.

The **Journal of Electrical Engineering** is indexed byScopus, and IEE INSPEC.



Academic Journal of Manufacturing and Engineering, Volume 12, Issue 1, 2, 3, 4
<http://eng.upt.ro/auif/journal.html>

The Academic Journal of Manufacturing Engineering intends to provide the specialists in the manufacturing engineering field a possibility for sharing and exchanging results and information by publishing the results of their work.
 Academic Journal of Manufacturing Engineering is recognized as a B+ journal by the Romanian National Council of Scientific Research and indexed by Index Copernicus international database.

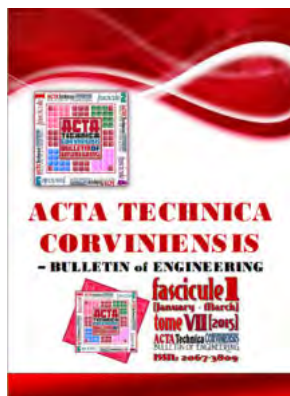

Acta Technica Corviniensis - Bulletin of Engineering, Volume 7, Issue 1, 2, 3, 4
<http://acta.fih.upt.ro/>

ACTA TECHNICA CORVINIENSIS – Bulletin of Engineering is an international and interdisciplinary journal of the Faculty of Engineering Hunedoara.
 The Journal is focused on engineering sciences and other innovative allied research areas, in all fields of science and technology on the basis of its originality, importance and timeliness.

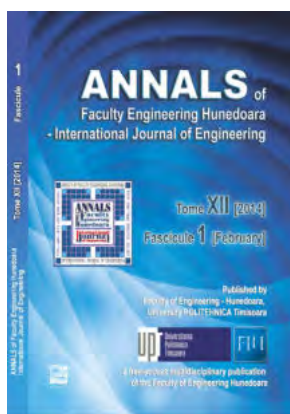

Annals of the Faculty Engineering Hunedoara International Journal of Engineering, Volume 14, Issue 1, 2, 3, 4
<http://annals.fih.upt.ro/>

The Journal is a multi-disciplinary journal which covers all aspects of scientific, engineering and technical disciplines including applications of scientific inventions for engineering, technological and industrial purposes, advances in engineering, technology and science.
 The Journal is accredited and ranked in the B+ category by The National University Research Council's Classification of Romanian Journals, CNCIS, and is indexed by Index Copernicus, Google Scholar, EBSCO Publishing, DOAJ, SCIRUS, EVISA, ProQuest, DRJI, CAS, BASE, etc.



The Nonconventional Technologies Review, Volume 18, Issue 1, 2, 3, 4
<http://www.revtn.ro/archives.htm>

The publication is addressed to all engineers and scientists interested on nonconventional technologies.
 The Journals is accredited and ranked in the B+ category by The National University Research Council's Classification of Romanian Journals, CNCIS, and is indexed by Index Copernicus, and ProQuest.

ISI PAPERS

ISI Publications

1. Ancuti, C., Ancuti, C. O. Effective Contrast-Based Dehazing for Robust Image Matching, IEEE GEOSCIENCE AND REMOTE SENSING LETTERS, Volume: 11, Issue: 11, Pages: 1871-1875;
2. Ancuti, M. C., Tutelea, L., Andreescu, G. D., Boldea, I. Practical Wide-speed-range Sensorless Control System for Permanent Magnet Reluctance Synchronous Motor Drives via Active Flux Model, ELECTRIC POWER COMPONENTS AND SYSTEMS, and Volume: 42, Issue: 1, Pages: 91-102;
3. Achilleos, M., Demetriou, M., Marinica, O., Vekas, L., Krasia-Christoforou, T. An innovative synthesis approach toward the preparation of structurally defined multiresponsive polymer (co)networks, POLYMER CHEMISTRY, Volume: 5 Issue: 14, Pages: 4365-4374, 2014;
4. Amaricai, A., Boncalo, O., Gavrilu, C.E. Low-precision DSP-based floating-point multiply-add fused for Field Programmable Gate Arrays, IET COMPUTERS AND DIGITAL TECHNIQUES, Volume: 8, Issue: 4, Pages: 187-197, 2014;
5. Anthimos A., Mosoarca, M., Gioncu, V., Investigation of the cyclic inelastic capacity of steel beams through the use of the plastic collapse mechanism, Bulletin of Earthquake Engineering, Print ISSN 1570-761X; Editura Springer Netherlands, 2014;
6. Ardelean, M., Manea, F., Vaszilcsin, N., Pode, R. Electrochemical detection of sulphide in water/seawater using nanostructured carbon-epoxy composite electrodes, ANALYTICAL METHODS Volume: 6 Issue: 13 Pages: 4775-4782, 2014;
7. Banica, R., Ursu, D., Sarvas, C., Rus, S. F., Novaconi, S. A. Kellenberger, A., Racu, V., Nyari, T. Electrical properties optimization of silver nanowires supported on polyethylene terephthalate, NANO – under review, manuscript number WSPC-NANO-D-14-00473, 2014;
8. Baschir, L., Fagadar-Cosma, E., Creanga, I., Palade, A., Lascu, A., Birdeanu, M., Savastru, D., Savu, V., Antohe, S., Velea, A., Fagadar-Cosma, G., Popescu, M., Simandan, I.D. UV Sensing effect in Langmuir-Blodgett complex films containing a novel synthesized Fe(iii) Porphyrin, Digest Journal of Nanomaterials and Biostructures, Volume: 9, Issue: 2, Pages: 847-857;
9. Belega, D., Macii, D., Petri, D. Fast Synchrophasor estimation by means of frequency-domain and time-domain algorithms, IEEE TRANSACTIONS ON INSTRUMENTATION AND MEASUREMENT, 2014;
10. Belega, D., Petri, D. Sine-wave parameter estimation by interpolated DFT method based on new cosine windows with high interference rejection capability, DIGITAL SIGNAL PROCESSING, 2014;
11. Belega, D., Petri, D., Dallet, D. Frequency estimation of a sinusoidal signal via a three-point interpolated DFT method with high image component interference rejection capability, DIGITAL SIGNAL PROCESSING, 2014;
12. Berer, M., Major, Z., Pinter, G., Constantinescu, D.M., Marsavina, L. Investigation of the dynamic mechanical behavior of polyetheretherketone (PEEK) in the high stress tensile regime, MECHANICS OF TIME-DEPENDENT MATERIALS, Volume: 18, Issue: 4, Pages: 663-684;
13. Berger, E.A., Milos, L. Researches Concerning LASER Welding of Diagnosis and Control Module, MATERIALE PLASTICE, Volume: 51, Issue: 1, Pages: 45-47, 2014;
14. Bernad, S.I., Bosioc, A., Bernad, E.S., Craina, M.L. Comparison between experimentally measured flow patterns for straight and helical type graft, BIO-MEDICAL MATERIALS AND ENGINEERING, 8 pag., 2014;
15. Birtea, P., Comanescu, D., Popa, C.A., Averaging on Manifolds by Embedding Algorithm, JOURNAL OF MATHEMATICAL IMAGING AND VISION, Volume: 49 Issue: 2, Pages: 454-466, 2014;
16. Bistriean, D.A., A solution of the parabolized Navier-Stokes stability model in discrete space by two-directional differential quadrature and application to swirl intense flows, COMPUTERS & MATHEMATICS WITH APPLICATIONS, Volume: 68, Issue: 3, Pages: 197-211, Impact factor 1.996;

17. Boeriu, C.G., Fitigau, F.I., Gosselink, R.J.A., Frissen, A. E., Stoutjesdijk, J., Peter, F. Fractionation of five technical lignins by selective extraction in green solvents and characterisation of isolated fractions, *INDUSTRIAL CROPS AND PRODUCTS*, Volume: 62, Pages: 481-490;
18. Boboescu, I.Z., Gherman, V.D., Ilie, M.; Mirel, I.; Vintila, T.; Maroti, G. Exploitation of experimental design methods and mathematical modeling for improving fermentative biohydrogen production processes, *ROMANIAN BIOTECHNOLOGICAL LETTERS*, Volume: 19 Issue: 2, Pages: 9097-9109, 2014;
19. Boboescu, I.Z., Gherman, V.D., Mirel, I., Pap, B., Tengolics, R., Rakhely, G., Kovacs, K.L., Kondorosi, E., Maroti, G. Simultaneous biohydrogen production and wastewater treatment based on the selective enrichment of the fermentation ecosystem, *INTERNATIONAL JOURNAL OF HYDROGEN ENERGY*, Volume: 39, Issue: 3, Pages: 1502-1510, 2014;
20. Boboescu, I.Z., Ilie, M., Gherman, V.D., Mirel, I., Pap, B., Negrea, A., Kondorosi, E., Biro, T., Maroti, G. Revealing the factors influencing a fermentative, *BIOTECHNOLOGY FOR BIOFUELS*, Volume: 7, Article Number: 139, 2014;
21. Boldea, I., Tutelea, L. N., Parsa, L. et al. Automotive Electric Propulsion Systems With Reduced or No Permanent Magnets: An Overview. *IEEE TRANSACTIONS ON INDUSTRIAL ELECTRONICS*, Volume: 61, Issue: 10, Pages: 5696-5711, 2014;
22. Boran, S., Tamas, A. Rheological behaviour of castor oil mixed with different pyromellitic esters, *JOURNAL OF THE SERBIAN CHEMICAL SOCIETY*, Volume: 79, Issue: 2, Pages: 241-251, 2014;
23. Borbath, T., Borbath, I., Gunther, S., Marinica, O., Vekas, L. Odenbach, S., Three-dimensional microstructural investigation of high magnetization nano-micro composite fluids using x-ray microcomputed tomography, *SMART MATERIALS AND STRUCTURES*, Volume: 23 Issue: 5, 2014;
24. Bota, C., Caruntu, B. Approximate Analytical Solutions of the Regularized Long Wave Equation Using the Optimal Homotopy Perturbation Method, *SCIENTIFIC WORLD JOURNAL*, 2014;
25. Bota, C., Caruntu, B., Bundau, O. Approximate Periodic Solutions for Oscillatory Phenomena Modelled by Nonlinear Differential Equations, *MATHEMATICAL PROBLEMS IN ENGINEERING*, Article Number: 513473, 2014;
26. Brzdek, J., Cadariu, L., Cieplinski, K., Fixed Point Theory and the Ulam Stability, *JOURNAL OF FUNCTION SPACES*, 2014
27. Calinoiu D., Stefu N., Paulescu M., Trif – Tordai G., Mares O., Paulescu E., Boata R., Pop N., Pacurar A., Evaluation of errors made in solar irradiance estimation due to averaging the Angstrom turbidity coefficient, *Atmospheric Research*, Vol. 150, p. 69-78, 2014. (FI= 2.421);
28. Calinoiu D, Ionel I, Sevaljevic M, Pavlovic M, Makra L, Vetres I, Trif-Tordai G., Thermodynamic study of atmospheric corrosion seasonal kinetic, based on sun photometer data, *Tehnicki Vjesnik-Technical Gazette*, Vol. 21(2), p. 283-290, 2014. (FI= 0.615);
29. Camacho, O.M.F., Norgard, P.B., Rao, N.L., Mihet-Popa, L. Electrical Vehicle Batteries Testing in a Distribution Network Using Sustainable Energy, *IEEE TRANSACTIONS ON SMART GRID*, Volume: 5, Issue: 2, Pages: 1033-1042, 2014;
30. Cercelaru, C., Ionel, I., Vetres, I. AIR POLLUTION ANALYSIS ESTABLISHED BY A DOAS SYSTEM, *JOURNAL OF ENVIRONMENTAL PROTECTION AND ECOLOGY*, Volume: 15, Issue: 2, Pages: 395-404, 2014;
31. Cemescu, A., Romanoff, J., Remes, H., Faur, N.; Jelovica, J. Equivalent mechanical properties for cylindrical cell honeycomb core structure, *COMPOSITE STRUCTURES*, Volume: 108, Pages: 866-875, 2014;
32. Ciocan, T., Susan-Resiga, R., Muntean, S. Improving Draft Tube Hydrodynamics Over A Wide Operating Range, *PROCEEDINGS OF THE ROMANIAN ACADEMY SERIES A-MATHEMATICS PHYSICS TECHNICAL SCIENCES INFORMATION SCIENCE*, Volume: 15, Issue: 2, Pages: 182-190, 2014;

33. Cocard, M., Marsavina, L. Determination of the Fracture Toughness of Thermoplastic Materials using the J Integral Method, *MATERIALE PLASTICE*, Volume: 51, Issue: 2, Pages: 190-193, 2014;
34. Corpas, L., Hadaruga, N.G., David, I., Pirsan, P., Hadaruga, D.I. Isengard, H.D., Karl Fischer Water Titration-Principal Component Analysis Approach on Wheat Flour, *FOOD ANALYTICAL METHODS*, Volume: 7, Issue: 6 Pages: 1353-1358, 2014;
35. Craciunescu, C. Ercuta, A. Prediction of thermally-controlled actuation for shape memory alloy film-based bimorph cantilevers, *SMART MATERIALS AND STRUCTURES*, Volume: 23, Issue: 7, 2014;
36. Craciunescu, M.C., Negrutiu, M.L., Hogeia, E. et al. Bacteriostatic Effect of Silver Nanoparticles over Acrylic Resin and Composite, *MATERIALE PLASTICE* Volume: 51, Issue: 4, Pages: 414-416, 2014;
37. Cretu, R., Kellenberger, A., Medeleanu, M., Vaszilcsin, N. Cathodic Hydrogen Evolution Reaction on Gold Catalyzed by Proton-Carriers, *INTERNATIONAL JOURNAL OF ELECTROCHEMICAL SCIENCE*, 9, pp. 4465-4477, 2014;
38. Crisan A., Ungureanu V., Dubina D. Influence of web members on the in-plane and out-of-plane capacities of steel storage upright frames, *THIN-WALLED STRUCTURES*, Volume 81, August 2014, pp. 175-184, 2014;
39. Cristea, A.D., Prostean, O., Muschalik, T., Tirian, O. Contribution to the Creation and Development of a New Authorization Concept Based on a Learning Process, *COMPUTER APPLICATIONS IN ENGINEERING EDUCATION* Volume: 22 Issue: 1, Pages: 1-10, 2014;
40. Curiac, D.I., Volosencu, C. A 2D chaotic path planning for mobile robots accomplishing boundary surveillance missions in adversarial conditions, *COMMUNICATIONS IN NONLINEAR SCIENCE AND NUMERICAL SIMULATION* Volume: 19 Issue: 10 Pages: 3617-3627;
41. Damacus, G., Iancu, A., Tucu, D. Packaging Penetration with Lamination Adhesive Components Compounds, *MATERIALE PLASTICE*, Volume: 51, Issue: 1, Pages: 86-89, 2014;
42. Davidescu, C.M., Ardelean, R., Popa, A.; Ilia, G., Iliescu, S.; Negrea, A.; Motoc, M. Removal of Phenolic Compounds from Aqueous Solutions using Poly(styrene-co-divinylbenzene) Functionalized with Aminophosphonic Acid, *REVISTA DE CHIMIE*, Volume: 65, Issue: 4, Pages: 444-446, 2014;
43. Dăianu, D. A stability criterion for Fréchet's first polynomial equation, *Aequationes Mathematicae*: Volume 88, Issue 3, Page 233-241, 2014;
44. Dăianu, D. Recursive procedure in the stability of Fréchet polynomials, *Advances in Difference Equations*, 2014 (IF 0.63);
45. Dăianu, D. Stability threshold for multiadditive and symmetric mappings, *Scientific Bulletin of the Politehnica University of Timișoara*, Tom 58(72), Fasc.2, pag. 41-48, 2014;
46. Dămăcuș, G., Iancu A., Țucu D., 2014, Packaging Penetration with Lamination Adhesive Components Compounds, *Revista de Materiale Plastice* 51, no 1, p. 86-89, 2014;
47. Dinu F., Dubina, D., Marginean, I. Improving the structural robustness of multi-story steel-frame buildings, *Structure and Infrastructure Engineering*, 2014;
48. Dorrell, D., Parsa, L., Boldea, I. Automotive Electric Motors, Generators, and Actuator Drive Systems with reduced or No Permanent Magnets and Innovative Design Concepts, *IEEE TRANSACTIONS ON INDUSTRIAL ELECTRONICS*, Volume: 61, Issue: 10, Pages: 5693-5695, 2014;

49. Dubina D., Ungureanu V. Instability mode interaction: from Van Der Neut model to ECBL approach. *Thin-Walled Structures*, Volume 81, August 2014, pp. 39–49; 2014;
50. Dubina D., Dinu F. Experimental evaluation of dual frame structures with thin-walled, steel panels, *Thin-walled structures*, vol. 78, Pages 57–69, 2014;
51. Ene, R. D. Contributions on the extension of the Optimal Homotopy Asymptotic Method in solution of the flow of the polymeric materials, *Materiale Plastice*, vol. 51, no.2, pag.194-200, 2014;
52. Fagadar-Cosmaa, G.; Taranu, B.O.; Birdeanu, M.; Popescu, M. ;Fagadar-Cosma, E., Influence Of 5,10,15,20-Tetrakis(4-Pyridyl)-21h, 23h Porphyrin On The Corrosion Of Steel In Aqueous Sulfuric Acid, *DIGEST JOURNAL OF NANOMATERIALS AND BIOSTRUCTURES*, Volume: 9, Issue: 2 Pages: 551-557, 2014;
53. Fagadar-Cosma, E., Vlascici, D., Fagadar-Cosma, G. et al. A Sensitive A(3)B Porphyrin Nanomaterial for CO2 Detection, *MOLECULES* Volume: 19, Issue:12, Pages: 21239-21252, 2014;
54. Falup, O., Mircea, I., Ivan, R., Ionel, I. Novel approach for the current state of greenhouse gases emissions. Romanian case study, *Journal of Environmental Protection and Ecology*, Volume: 15 Issue: 3 Pages: 807-818, 2014;
55. Fatu, M., Blaabjerg, F., Boldea, I. Grid to stand alone Transition Motion-Sensor less Dual-Inverter Control of PMSG with Asymmetrical Grid Voltage Sags and Harmonics Filtering, *IEEE TRANSACTIONS ON POWER ELECTRONICS*, Volume: 29, Issue: 7, Pages: 3463-3472, 2014;
56. Filip-Vacarescu, N., Stratan A., Dubina D. Experimental validation of a strain hardening friction damper, *Proceeding of the Romanian Academy, Series A*, Volume 15, Number 1/2014, pp. 60–67, 2014;
57. Filip-Vacarescu N., Stratan A., Dubina D. Seismic performance of multistorez steel frames with strain hardening friction dampers, *Proceeding of the Romanian Academy, Series A*, Volume 15, Number 2/2014, pp. 174–181, 2014;
58. Florea, D., Dubina, D., Marginean, I. Improving the structural robustness of multi-story steel-frame buildings, *Structure and Infrastructure Engineering*, DOI: 10.1080/15732479.2014.927509, 2014;
59. Florut, S.C., Sas, G., Popescu, C., Stoian, V. Tests on reinforced concrete slabs with cut-out openings strengthened with fibre-reinforced polymers, *COMPOSITES PART B-ENGINEERING*, Volume: 66, Pages: 484-493, 2014;
60. Georgescu M, Ungureanu V. Stabilisation of continuous Z-purlins by sandwich panels: Full scale experimental approach, *THIN-WALLED STRUCTURES*, Volume 81, August 2014, pp. 242–249, 2014;
61. Gioncu, V., Anastasiadis, A. Plastic coupled instabilities of I-shaped steel beams, *THIN-WALLED STRUCTURES*, Volume: 81, Pages: 67-77, Special Issue: SI, 2014;
62. Gioncu, V., Mosoarca M., Anthimos, A, Local ductility of steel elements under near-field earthquake loading, *Journal of Constructional Steel Research*, Volume 101, Octombrie 2014, Pages 33–52, Editura Elsevier, ISSN: 0143-974X, 2014;
63. Grecea, C., Moscovici, A. M., Vilceanu, C. B., Herban, S. I., Comparative overview of cadastre and land information systems in some countries from Europe—an efficient tool to understand and manage urban development, *JOURNAL OF ENVIRONMENTAL PROTECTION AND ECOLOGY*, Volume: 15 Issue: 2, Pages: 678-685, 2014;
64. Gherman, V.D., Boboescu, I.Z., Pap, B., Kondorosi, E., Gherman, G. Maroti, G. An Acidophilic Bacterial- Archaeal- Fungal Ecosystem Linked to Formation of Ferruginous Crusts and Stalactites, *GEOMICROBIOLOGY JOURNAL*, Volume: 31, Issue: 5, Pages: 407-418;

65. Groza, B., Warinschi, B. Cryptographic puzzles and DoS resilience, revisited, *DESIGNS CODES AND CRYPTOGRAPHY*, Volume: 73, Issue: 1, Pages: 177–207, 2014;
66. Gurban, E.H., Dragomir, T.L., Andreescu, G.D. Greenhouse Climate Control Enhancement by Using Genetic Algorithms, *CONTROL ENGINEERING AND APPLIED INFORMATICS*, Volume: 16, Issue: 3, Pages: 35–45, 2014;
67. Gurbina, M., Lascu, D. Stability Aspects in One-Cycle Controlled Buck Converters, *ADVANCES IN ELECTRICAL AND COMPUTER ENGINEERING*, Volume: 14, Issue: 1, Pages: 43–48, 2014;
68. Hadaruga, D.I., Hadaruga, N.G., Costescu, C.I.; David, I.; Gruia, A.T. Thermal and oxidative stability of the *Ocimum basilicum* L. essential oil/ β -cyclodextrin supramolecular system, *BEILSTEIN JOURNAL OF ORGANIC CHEMISTRY*, Volume: 10 Pages: 2809–2820, 2014;
69. Haddad, K., Flavio, J., Tutelea, L. N., Boldea, I. et al. 2/4-POLE Split-Phase Capacitor Motor for Small Compressors: A Comprehensive Motor Characterization, *IEEE TRANSACTIONS ON INDUSTRY APPLICATIONS*, Volume: 50, Issue: 1, Pages: 356–363, 2014;
70. Hedrea, C., Zaharie, I., Negrea, R., Danci, E., Patrascoiu, M., On the Efficiency of the Paraboloidal Concentrator Installed on Oriented Roofs, *Buletinul Stiintific al UPT, Seria Matematica-Fizica, Tom 59 (73), Fascicola 2*, pp. 47–56, 2014;
71. Heghedus-Mindru, R.C., Heghedus-Mindru, G.; Negrea, P.; Sumalan, R., Negrea, A.; Stef, D. The monitoring of mineral elements content in fruit purchased in supermarkets and food markets in Timisoara, Romania, *ANNALS OF AGRICULTURAL AND ENVIRONMENTAL MEDICINE*, Volume: 21 Issue: 1 Pages: 98–105, 2014;
72. Henk A., Dijkstra, F., Wubs, W A., Cliffe, K., Doedel, E., Dragomirescu, I. F., Eckhardt, B., Yu. A., Gelfgat, A. L., Hazel, V. L., Andy G. S., Erik T. P., Sanchez-Umbria, J., Schuttelaars, H., Tuckerman, L. S., Thiele, U. Numerical Bifurcation Methods and their Application to Fluid Dynamics: Analysis beyond Simulation, *Commun. Comput. Phys.*, 15 (2014), pp. 1–45, 2014;
73. Herban, S.I., Rusu, G., Grecea, O., Birla, G.A., Using the laser scanning for research and conservation of cultural heritage sites. Case study: Ulmetum Citadel, *JOURNAL OF ENVIRONMENTAL PROTECTION AND ECOLOGY*, Volume: 15 Issue: 3, Pages: 1172–1180, 2014;
74. Herban, S.I., Vilceanu, C.B., Alionescu, A., Grecea, C. Studying the movement of buildings and developing models to determine real settlements, *JOURNAL OF ENVIRONMENTAL PROTECTION AND ECOLOGY*, Volume: 15 Issue: 2, Pages: 789–796, Published: 2014;
75. Hulka, I. et. al. Properties of WC-FeCrAl coatings manufactured by different high velocity thermal spray processes, *SURFACE & COATINGS TECHNOLOGY* Volume: 247, Pages: 74–89;
76. Hutiu, G., Duma, V.F., Demian, D., Bradu, A., Podoleanu, A.G. Surface imaging of metallic material fractures using optical coherence tomography, *APPLIED OPTICS*, Volume: 53, Issue: 26, Pages: 5912–5916, 2014;
77. Ianos, R. Highly sinterable cobalt ferrite particles prepared by a modified solution combustion synthesis, *MATERIALS LETTERS*, Volume: 135, Pages: 24–26, 2014;
78. Ianos, R., Babuta, R., Lazau, R. Characteristics of Y2O3 powders prepared by solution combustion synthesis in the light of a new thermodynamic approach, *CERAMICS INTERNATIONAL*, Volume: 40, Issue: 8, Pages: 12207–12211 Part: A, 2014;
79. Ianos, R., Borcanescu, S., Lazau, R. Large surface area ZnAl2O4 powders prepared by a modified combustion technique, *CHEMICAL ENGINEERING JOURNAL*, Volume: 240 Pages: 260–263, 2014;
80. Ianos, R., Bosca, M., Lazau, R. Fine tuning of CoFe2O4 properties prepared by solution combustion synthesis, *CERAMICS INTERNATIONAL*, Volume: 40 Issue: 7, Pages: 10223–10229, Part: B, 2014;

81. Ianos, R., Lazau, R., Borcanescu, S., Babuta, R. Single-step combustion synthesis of LaAlO₃ powders and their sintering behavior, CERAMICS INTERNATIONAL, Volume: 40, Issue: 5, Pages: 7561-7565, 2014;
82. Ianos, R., Lazau, R. Chromium-doped calcium zirconate A potential red shade pigment: Preparation, characterization and testing, DYES AND PIGMENTS, Volume: 105, Pages: 152-156, 2014;
83. Ianos, R., Pacurariu, C., Mihoc, G. Magnetite/carbon nanocomposites prepared by an innovative combustion synthesis technique-Excellent adsorbent materials, CERAMICS INTERNATIONAL, Volume: 40, Issue: 8, Pages: 13649-13657, Part: B, 2014;
84. Iosif, A., Sarbu, I. Numerical modeling of cavitation characteristics and sensitivity curves for reversible hydraulic machinery, ENGINEERING ANALYSIS WITH BOUNDARY ELEMENTS, vol. 41, no. 4, 2014, (FI=1,437);
85. Irimescu, A., Marchitto, L., Merola, S.S., Tomatore, C., Valentino, G. Evaluation of different methods for combined thermodynamic and optical analysis of combustion in spark ignition engines, ENERGY CONVERSION AND MANAGEMENT, Volume: 87, Pages: 914-927, 2014;
86. Irimescu, A., Vasiu, G., Tordai, G.T. Performance and emissions of a small scale generator powered by a spark ignition engine with adaptive fuel injection control, APPLIED ENERGY, Volume: 121, Pages: 196-206, 2014;
87. Isar, A., Naforita, C. On the statistical decorrelation of the 2D discrete wavelet transform coefficients of a wide sense stationary bivariate random process, DIGITAL SIGNAL PROCESSING, Volume: 24, Pages: 95-10, 2014;
88. Isvoran, A., Craciun, D., Ciorsac, A., Perrot, N., Beswick, V., Nedellec, P., Sanson, A., Jamin, N. A bioinformatics study concerning the structural and functional properties of human caveolin proteins, JOURNAL OF THE SERBIAN CHEMICAL SOCIETY, Volume: 79, Issue: 2, Pages: 133-150, 2014;
89. Jivanescu, A., Bratu, D.C., Zaharia, R. et al. Tensile Bond Strength Evaluation of Two Adhesive Cements Used for Bonding Orthodontic Metal Brackets to Porcelain Fused-to-metal Crowns, MATERIALE PLASTICE, Volume: 51, Issue: 4, Pages: 465-467, 2014;
90. Jivulescu, M.A., Lupa, N., Nechita, I. On the reduction criterion for random quantum states, JOURNAL OF MATHEMATICAL PHYSICS, Volume: 55, Issue: 11, 2014;
91. Jitian, S., White, S.R.; Yang, H.H.W., Weisz, A. Conventional high-performance liquid chromatography versus derivative spectrophotometry for the determination of 1,3,6-pyrenetrisulfonic acid trisodium salt and 1,3,6,8-pyrenetetrasulfonic acid tetrasodium salt in the color additive D&C Green No. 8 (Pyranine), 2014;
92. Kalluf, F.J.H., Tutelea, L.N., Boldea, I., Espindola, A. 2/4-POLE Split-Phase Capacitor Motor for Small Compressors: A Comprehensive Motor Characterization, IEEE TRANSACTIONS ON INDUSTRY APPLICATIONS, Volume: 50, Issue: 1, Pages: 356-363, 2014;
93. Kellenberger, A., Ambros, D., Plesu, N. Scan Rate Dependent Morphology of Polyaniline Films Electrochemically Deposited on Nickel, INTERNATIONAL JOURNAL OF ELECTROCHEMICAL SCIENCE, 9, 6821-6833, 2014;
94. Lazau, I., Vancea, C. New vitreous matrix for chromium waste immobilization, CENTRAL EUROPEAN JOURNAL OF CHEMISTRY, Volume: 12, Issue: 7, Pages: 763-768, Special Issue: SI, 2014;
95. Ledeti, I., Vlase, G., Vlase, T., Doca, N., Bercean, V., Fulias, A. Thermal decomposition, kinetic study and evolved gas analysis of 1,3,5-triazine-2,4,6-triamine, JOURNAL OF THERMAL ANALYSIS AND CALORIMETRY, Volume: 118, Issue: 2, Pages: 1057-1063, 2014;
96. Ledeti, I., Bosca, C.S., Cosma, C., Badea, V., Todea, A., Bercean, V.N. Study on Obtaining 3-oxolup-20(29)-en-28-oic Acid (Betulonic Acid) from (3 beta)- lup-20(29)-en-3,28-diol (betulin), REVISTA DE CHIMIE, Volume: 65 Issue: 11, Pages: 1289-1293, 2014;

97. Lelea, D., Laza, I. The water based Al₂O₃ nanofluid flow and heat transfer in tangential microtube heat sink with multiple inlets, *International Journal of Heat and Mass Transfer*, Volume 69, Pages 264–275 (Factor de impact = 2,522), 2014;
98. Lelea, D., Laza, I. The particle thermal conductivity influence of nanofluids on thermal performance of the microtubes, *International Communications in Heat and Mass Transfer*, Volume 59, Pages 61–67 (Factor de impact = 2,124), 2014;
99. Lemle, L.D. On Some Approximation Theorems for Power q -Bounded Operators on Locally Convex Vector Spaces, *SCIENTIFIC WORLD JOURNAL*, Article Number: 513162, 2014;
100. Lemle, L.D. On the L-infinity-uniqueness of multidimensional Nelson's diffusion, *CARPATHIAN JOURNAL OF MATHEMATICS* Volume: 30, Issue: 2, Pages: 209–215, 2014;
101. Lemle, L.D., Wang, R., Wu, L.M. Uniqueness of Fokker-Planck equations for spin lattice systems (II): Non-compact case, *SCIENCE CHINA MATHEMATICS*, Volume: 57, Issue: 1, Pages: 161–172, 2014;
102. Lupa, N. Roughness of $Z(+)$, $Z(-)$ -Nonuniform Exponential Dichotomy for Difference Equations in Banach Spaces, *SCIENTIFIC WORLD JOURNAL*, Article Number: 819046, 2014;
103. Lupulescu, D., Hedrea, C., Cofan, N. Interpolation between Sum and Intersection of Frechet Space, *Buletinul Stiintific al UPT, Seria Matematica Fizica*, Tom 59 (73), Fascicola 2, pp. 17–30, 2014;
104. Lupulescu, D., Hedrea, C., Stan, I. Some Properties of Interpolation of Locally Convex Couples, *Buletinul Stiintific al UPT, Seria Matematica-Fizica*, Tom 59 (73), Fascicola 2, pp. 39–46, 2014;
105. Marinca V., Ene, R. D., Dual approximate solutions of the unsteady viscous flow over a shrinking cylinder with Optimal Homotopy Asymptotic Method, *Advances in Mathematical Physics*, Special Issue: Nonlinear Fluid Flow and Heat Transfer (NFFH), Article ID: 417643, 2014;
106. Marinca, V., Ene R. D., Marinca, B. Analytic approximate solution for Falkner – Skan equation, *The Scientific World Journal*, Special Issue: Dynamics of Nonlinear Systems (DNS), Article ID: 617453, 2014;
107. Marinca V., Ene R. D. Analytical approximate solutions to the Thomas-Fermi equation, *Central European Journal of Physics*, Vol. 12, Nr. 7, 2014, pp. 503–510;
108. Marinca V., Ene R. D., Marinca, B., Negrea, R. Different approximations to the solution of upper-convected Maxwell fluid over a porous stretching plate, *Abstract and Applied Analysis*, Special Issue: Complex Boundary Value Problems of Nonlinear Differential Equations 2014 (CBV14), Article ID: 139314, 2014;
109. Marinca, V. Herisanu, N. On the flow of a Walters-type B' viscoelastic fluid in a vertical channel with porous wall, *INTERNATIONAL JOURNAL OF HEAT AND MASS TRANSFER*, Volume: 79, Pages: 146–165, 2014;
110. Marinca, V., Herisanu, N. The Optimal Homotopy Asymptotic Method for solving Blasius equation, *APPLIED MATHEMATICS AND COMPUTATION*, Volume: 231, Pages: 134–139, 2014;
111. Menezes, P.P, Serafini, M.R, Quintans, L.J., Silva, G.F, Oliveira, J.F., Carvalho, F.M.S., Souza, J.C.C., Matos, J.R., Alves, P.B., Matos, I.L., Hadaruga, D.I., Araujo, A.A.S. Inclusion complex of (-)-linalool and beta-cyclodextrin, *JOURNAL OF THERMAL ANALYSIS AND CALORIMETRY*, 9 pag., 2014;
112. Merola, S.S., Marchitto, L., Tornatore, C., Valentino, G., Irimescu, A. Optical characterization of combustion processes in a DISI engine equipped with plasma-assisted ignition system, *APPLIED THERMAL ENGINEERING*, Volume: 69, Issue: 1–2, Pages: 177–187, 2014;

113. Miclau, M., Miclau, N. Low-temperature hydrothermal synthesis of the three-layered sodium cobaltite $P3-NaxCoO_2$ (x similar to 0.60), *MATERIALS RESEARCH BULLETIN*, Volume: 54, Pages: 1-5, 2014
114. Mihoc, G., Ianos, R., Pacurariu, C. Adsorption of phenol and p-chlorophenol from aqueous solutions by magnetic nanopowder, *WATER SCIENCE AND TECHNOLOGY*, Volume: 69, Issue: 2, Pages: 385-391, 2014;
115. Milos, T., Bordeasu, I., Badarau, R., Bej, A., Bordeasu, D., Failure Cause Analysis of a 5 KW Wind Turbine Blade in Extreme Wind Conditions, *MATERIALE PLASTICE*, Volume: 50, Issue: 4, ISSN: 0025-5289, Pages: 279-284, 2014;
116. Minculete, N., Ciurdariu, L. A generalized form of Gruss type inequality and other integral inequalities, *JOURNAL OF INEQUALITIES AND APPLICATIONS*, 2014;
117. Mitelea, I., Dimian, E., Bordeasu, I., Craciunescu, C.- Ultrasonics Sonochemistry Volume: 21, Issue: 4, Published: JUL 2014, ISSN: 1350-4177, Pages: 1544-1548, 2014;
118. Mitelea, I., Groza, C., Craciunescu, C.M. Pulsed Laser Processing of Dissimilar Ti-6Al-4V and X5CrNi18-10 Joints, *MATERIALS AND MANUFACTURING PROCESSES*, Volume: 29 Issue: 8, Pages: 975-979, 2014
119. Morar, T., Radoslav, R., Spiridon, L.C., Pacurar, L. Assessing Pedestrian Accessibility To Green Space Using Gis, *TRANSYLVANIAN REVIEW OF ADMINISTRATIVE SCIENCES*, Issue: 42E Pages: 116-139, 2014;
120. Mosoarca, M., Failure analysis of RC shear walls with staggered openings under seismic loads, *ENGINEERING FAILURE ANALYSIS*, Volume: 41 Pages: 48-64 Special Issue: SI, 2014;
121. Mosoarca, M., Anastasiadis A., Apostolos, K. Are free form architectures ecological buildings?, *Journal of Environmental Protection and Ecology*, vol.15, no.1 pp. 359-366, ISSN 1311-5065, 2014;
122. Motapon O, Pop N., Argoubi F, Mezei J, Epee MDE, Faure A, Telmini M, Tennyson J, Schneider IF, Rotational transitions induced by collisions of HD+ ions with low-energy electrons", *PHYSICAL REVIEW A*, 90(1), 012706-1; 012706-9, (FI:-2.729), 2014;
123. Negrea, A., Popa, A., Ciopec, M.; Lupa, L., Negrea, P., Davidescu, CM., Motoc, M., Minzatu, V. Phosphonium grafted styrene-divinylbenzene resins impregnated with iron(III) and crown ethers for arsenic removal, *PURE AND APPLIED CHEMISTRY*, Volume: 86, Issue: 11, Pages: 1729-1740, 2014;
124. Negru, R., Muntean, S., Pasca, N., Marsavina, L. Failure assessment of the shaft of a pumped storage unit, *FATIGUE & FRACTURE OF ENGINEERING MATERIALS & STRUCTURES*, Volume: 37, Issue: 7, Pages: 807-820, Special Issue: SI, 2014;
125. Pana, A.M., Badea, V., Banica, R., Bora, A., Dudas, Z., Cseh, L., Costisor, O. Network reaction of 2,6-bis(2-hydroxybenzylidene)cyclohexanone by external stimuli Network reaction of 2,6-bis(2-hydroxybenzylidene)cyclohexanone by external stimuli, *JOURNAL OF PHOTOCHEMISTRY AND PHOTOBIOLOGY A-CHEMISTRY*, Volume: 283, Pages: 22-28, 2014;
126. Paska, O., Ianos, R., Pacurariu, C., Bradeanu, A. Magnetic nanopowder as effective adsorbent for the removal of Congo Red from aqueous solution, *WATER SCIENCE AND TECHNOLOGY*, Volume: 69, Issue: 6, Pages: 1234-1240, 2014;
127. Paulescu M., Mares O., Paulescu E., Stefu N., Pacurar A., Calinoiu D., Gravila P., Pop N., Boata R., Nowcasting solar irradiance using the sunshine number, *Energy Conversion and Management*, Vol. 79, p. 690-697, 2014. (FI= 3.590), 2014;
128. Paulescu, M., Badescu, V., Dughir, C. New procedure and field-tests to assess photovoltaic module performance, *ENERGY*, Volume: 70, Pages: 49-57, 2014;

129. Paunescu, V., Bojin, F.M., Gavriluc, O.I., Taculescu, E.A., Ianos, R., Ordodi, V.L., Iman, V.F., Tatu, C.A. Enucleation: a possible mechanism of cancer cell death, *JOURNAL OF CELLULAR AND MOLECULAR MEDICINE*, Volume: 18, Issue: 6, Pages: 962-965, 2014;
130. Pescaru, D., Curiac D.I., Anchor Node Localization for Wireless Sensor Networks Using Video and Compass Information Fusion, *Sensors*, Vol. 14(3), MDPI Basel, March 2014, pp. 4211-4224. (ISI IF = 2.084), 2014;
131. Pescaru, D., Curiac D.I., Ensemble based traffic light control for city zones using a reduced number of sensors", *Transportation Research Part C: Emerging Technologies*, Elsevier, Vol. 46, September 2014, pp. 261-273 (IF = 2.820), 2014;
132. Petrisor, C., Some New Remarks about the Dynamics of an Automobile with Two Trailers, *JOURNAL OF APPLIED MATHEMATICS*, 2014;
133. Petrisor, E., Monotone gradient dynamics and the location of stationary (p, q)-configurations, *JOURNAL OF PHYSICS A-MATHEMATICAL AND THEORETICAL*, Volume: 47, Issue: 4, 2014;
134. Pomarlan, M. Visibility-based Planners for Mobile Robots Capable to Handle Path Existence Queries in Temporal Logic, *ADVANCES IN ELECTRICAL AND COMPUTER ENGINEERING*, Volume: 14, Issue: 1, Pages: 55-64, 2014;
135. Pop N., Pacurar A., Boata, R., Gravila, P., Paulescu M. The assessment of beam solar irradiance using parametric modeling", *International Journal of Green Energy*, Volume: 11, Issue: 8, Pages: 876-885, (FI: 2.07), 2014;
136. Popa, A., Ciopec, M.; Negrea, A. Lupa, L., Negrea, P., Davidescu, C.M., Ilia, G., Duteanu, N. Use of styrene-divinylbenzene grafted with aminoethylaminomethyl groups and various ionic liquids in the removal process of thallium and strontium, *PURE AND APPLIED CHEMISTRY*, Volume: 86, Issue: 11, Pages: 1741-1753, 2014;
137. Popa, G.N., Dăscălescu L. Variable cross-section cylinder-type corona and combined corona-dielectric barrier discharge precipitators for fly-ASH particles, *Particulate Science and Technology*, Taylor & Francis Inc., Vol.32, Issue 5, pp. 445-450, U.S.A., 2014;
138. Popa, G.N., Sora, I., Diniș, C.M., Deaconu, S.I. An analysis on the velocity of dust particles in the plate-type electrostatic precipitators used in thermoelectric power plants, *environment protection engineering*, vol.40, Issue, 1, pp. 85-102, Poland, 2014;
139. Popov, D., Pop, N. Statistical Properties of the Excited Binomial States for the Pseudoharmonic Oscillator, *CHINESE JOURNAL OF PHYSICS*, Volume: 52, Issue: 2, Pages: 738-769, 2014;
140. Pozna, C., Precup, R.E. Applications of Signatures to Expert Systems Modelling, *ACTA POLYTECHNICA HUNGARICA*, Volume: 11, Issue: 2, Pages: 21-39, 2014;
141. Precup, R.E., David, R.C., Petriu, E.M, Preitl, S., Radac, M.B. Novel Adaptive Charged System Search algorithm for optimal tuning of fuzzy controllers, *EXPERT SYSTEMS WITH APPLICATIONS*, Volume: 41, Issue: 4, Pages: 1168-1175, Part: 1, 2014;
142. Precup, R.E., David, R.C., Petriu, E.M., Radac, M.B., Preitl, S. Adaptive GSA-Based Optimal Tuning of PI Controlled Servo Systems With Reduced Process Parametric Sensitivity, Robust Stability and Controller Robustness, *IEEE TRANSACTIONS ON CYBERNETICS*, Volume: 44, Issue: 11, Pages: 1997-2009, Special Issue: SI, 2014;
143. Precup, R.E., Filip, H.I., Radac, M.B., Petriu, E.M., Preitl, S., Dragos, C.A. Online identification of evolving Takagi-Sugeno-Kang fuzzy models for crane systems, *APPLIED SOFT COMPUTING*, Volume: 24, Pages: 1155-1163, 2014;
144. Precup, R.E., Tomescu, M.L., Dragos, C.A. Stabilization of ROssler chaotic dynamical system using fuzzy logic control algorithm, *INTERNATIONAL JOURNAL OF GENERAL SYSTEMS*, Volume: 43, Issue: 5, Pages: 413-433, 2014;

145. Radac M.B., Precup, R.E., Petriu, E.M., Preitl, S. Iterative Data-Driven Tuning of Controllers for Nonlinear Systems with Constraints, IEEE Transactions on Industrial Electronics, vol. 61, no. 4, pp. 6360–6368, 2014, (FI= 6.500), 2014;
146. Radac, M.B., Precup, R.E., Petriu, E.M., Preitl, S. Iterative Data-Driven Controller Tuning with Actuator Constraints and Reduced Sensitivity, JOURNAL OF AEROSPACE INFORMATION SYSTEMS, Volume: 11, Issue: 9, Pages: 551–564, Special Issue: SI, 2014;
147. Raduca, M., Hatiegan, C., Pop, N., Raduca, E., Gillich, G.R. Finite element analysis of heat transfer in transformers from high voltage stations, JOURNAL OF THERMAL ANALYSIS AND CALORIMETRY, Volume: 118, Issue: 2, Pages: 1355–1360, 2014;
148. Reisz, E., Fischbacher, A., Naumov, S., von Sonntag, C., Schmidt, T.C. Hydride Transfer: A Dominating Reaction of Ozone with Tertiary Butanol and Formate Ion in Aqueous Solution, OZONE–SCIENCE & ENGINEERING, Volume: 36, Issue: 6, Pages: 532–539, 2014;
149. Rus, S.F., Vlazan, P., Herklotz, A. Effect of non-magnetic ion substitution on the magnetoelastic properties of CoFe₂O₄ films, JOURNAL OF APPLIED PHYSICS, Volume: 116, Issue: 1, 2014;
150. Sas, G., Daescu, C., Popescu, C., Nagy-Gyorgy, T. Numerical optimization of strengthening disturbed regions of dapped-end beams using NSM and EBR CFRP, COMPOSITES PART B-ENGINEERING, Volume: 67, Pages: 381–390, 2014;
151. Sarbu, I. A review on substitution strategy of non-ecological refrigerants from vapour compression-based refrigeration, air-conditioning and heat pump systems, INTERNATIONAL JOURNAL OF REFRIGERATION, vol. 46, no. 10, (FI=1,702), 2014;
152. Sarbu, I. Nodal analysis of urban water distribution networks, WATER RESOURCES MANAGEMENT, vol. 28, no. 10, (FI=2,463), 2014;
153. Sarbu, I., Adam, M. Experimental and numerical investigations of the energy efficiency of conventional air conditioning systems in cooling mode and comfort assurance in office buildings, ENERGY AND BUILDINGS, vol. 85, no. 12, (FI=2,465), 2014;
154. Sarbu, I., Sebarchievici, C. General review of ground-source heat pump systems for heating and cooling of buildings, ENERGY AND BUILDINGS, vol. 70, no. 2, (FI=2,465), 2014;
155. Sarbu, I., Sebarchievici, C. A study of the performances of low-temperature heating systems, ENERGY EFFICIENCY, (FI=0,961), 2014;
156. Sarbu, I., Valea, E.S. Water pool boiling heat transfer enhancement for modified surface tubes, INTERNATIONAL COMMUNICATIONS IN HEAT AND MASS TRANSFER, vol. 50, no.1, (FI=2,124), 2014;
157. Savva, I., Constantinou, D., Marinica, O., Vasile, E., Vekas, L., Krasia-Christoforou, T. Fabrication and characterization of superparamagnetic poly(vinyl pyrrolidone)/poly(L-lactide)/Fe₃O₄ electrospun membranes, JOURNAL OF MAGNETISM AND MAGNETIC MATERIALS, Volume: 352 Pages: 30–35, 2014;
158. Savva, I., Odysseos, A.D., Evaggelou, L., Marinica, O., Vasile, E., Vekas, L., Sarigiannis, Y., Krasia-Christoforou, T. Fabrication, Characterization, and Evaluation in Drug Release Properties of Magnetoactive Poly(ethylene oxide)-Poly(L-lactide) Electrospun Membranes, BIOMACROMOLECULES, Volume: 14, Issue: 12, Pages: 4436–4446, 2014;
159. Sirbu, N. A., Serban, A. V., Savu, S. Influence of the Ultrasonic Microvibrations under the Processing of the HDPE Thermoplastic Material, Materiale Plastice, Volume 51, No. 4, pp. 401–404; 2014;
160. Serban, V.A., Utu, D., Marginean, G. Corrosion and sliding wear behavior of Cr₃Cr₂-NiCr coatings alloyed by electron beam treatment, OPTOELECTRONICS AND ADVANCED MATERIALS-RAPID COMMUNICATIONS, Volume: 8, Issue: 1–2, Pages: 153–157, 2014;

161. Serban, V.A., Codrean, C., Voda, M., Chicot, D., Decoopman, X. Correlation between yield stress and hardness of nickel-silicon-boron-based alloys by nanoindentation, *MATERIALS SCIENCE AND ENGINEERING A-STRUCTURAL MATERIALS PROPERTIES MICROSTRUCTURE AND PROCESSING*, Volume: 605, Pages: 294-300, 2014;
162. Solomonesc, F., Barbulescu, C., Kilyeni, S., Pop, O., Cornoiu, M., Olariu, A. EA Techniques for Optimal Power Flow. Parameter Tuning by Mathematical Test Functions, *ACTA POLYTECHNICA HUNGARICA*, Volume: 11, Issue: 1, Pages: 153-172, 2014;
163. Staniloiu, C., Florescu, C. Considerations for Optimization of Biological Treatment Process for Small Wastewater Treatment Plant, *REVISTA DE CHIMIE*, Volume: 65, Issue: 4, Pages: 502-505, 2014;
164. Stoia, M., Barvinschi, P., Barvinschi, F. Structural and morphologic characterization of zirconia-silica nanocomposites prepared by a modified sol-gel method, *JOURNAL OF CRYSTAL GROWTH*, Volume: 401, Pages: 462-468, 2014;
165. Stoica, M., Scudino, S., Bednarcik, J., Kaban, I., Eckert, J. FeCoSiBNbCu bulk metallic glass with large compressive deformability studied by time-resolved synchrotron X-ray diffraction, *JOURNAL OF APPLIED PHYSICS*, Volume: 115, Issue: 5, 2014;
166. Susan-Resiga, D., Vekas, L. Yield stress and flow behavior of concentrated ferrofluid-based magnetorheological fluids: the influence of composition, *RHEOLOGICA ACTA*, Volume: 53, Issue: 8, Pages: 645-653, 2014;
167. Tatu, R.F., Marsavina, L., Voiconi, T., et al. Reinforcement of Tibial Fixation in Anterior Cruciate Ligament Reconstruction Using a Polyester Multi Stranded Long Chain Polyethylene Core Suture Material, *MATERIALE PLASTICE*, Volume: 51, Issue: 4, Pages: 460-462, 2014;
168. Taghvaei, A.H., Stoica, M., Bednarcik, J., Kaban, I., Shahab, H.S., Khoshkhou, M.S., Janghorban, K., Eckert, J. Influence of ball milling on atomic structure and magnetic properties of Co₄₀Fe₂₂Ta₈B₃₀ glassy alloy, *MATERIALS CHARACTERIZATION*, Volume: 92, Pages: 96-105, 2014;
169. Taghvaei, A.H., Stoica, M., Kaban, I., Bednarcik, J., Eckert, J. Thermal and soft magnetic properties of Co₄₀Fe₂₂Ta₈B₃₀ glassy particles: In-situ X-ray diffraction and magnetometry studies, *JOURNAL OF APPLIED PHYSICS*, Volume: 116, Issue: 5, 2014;
170. Taghvaei, A.H., Stoica, M., Song, K., Janghorban, K., Eckert, J. Crystallization kinetics of Co₄₀Fe₂₂Ta₈B₃₀ glassy alloy with high thermal stability and soft magnetic properties, *JOURNAL OF ALLOYS AND COMPOUNDS*, Volume: 605, Pages: 199-207, 2014;
171. Tita, B., Ledeti, I., Bandur, G., Tita, D. Compatibility study between indomethacin and excipients in their physical mixtures, *JOURNAL OF THERMAL ANALYSIS AND CALORIMETRY*, Volume: 118, Issue: 2, Pages: 1293-1304, 2014;
172. Tigan, G. Analysis of a two-dimensional nonsmooth Poincaré-like map, *NONLINEAR DYNAMICS*, Volume: 75, Issue: 4, Pages: 643-651, 2014;
173. Tirian, G.O., Filip, I., Prostean, G. Adaptive control system for continuous steel casting based on neural networks and fuzzy logic, *NEUROCOMPUTING*, Volume: 125, Pages: 236-245, Special Issue: SI, 2014;
174. Tiwari, A.K., Oros, C., Albulescu, C.T. Revisiting the inflation-output gap relationship for France using a wavelet transform approach, *ECONOMIC MODELLING*, Volume: 37, Pages: 464-475, 2014;
175. Todea, A., Biro, E., Badea, V., Paul, C., Cimporescu, A., Nagy, L., Kéki, S., Bandur, G., Boeriu, C., Peter, F. Optimization of enzymatic ring-opening copolymerizations involving δ -gluconolactone as monomer by experimental design, *Pure and Applied Chemistry*, 2014, 86, 1781-1792, ISSN (Online) 1365-3075, ISSN (Print) 0033-4545, 2014;
176. Todea, A., Badea, V., Nagy, L., Keki, S., Boeriu, C.G., Peter, F. Biocatalytic synthesis of delta-gluconolactone and epsilon-caprolactone copolymers, *ACTA BIOCHIMICA POLONICA*, Volume: 61, Issue: 2, Pages: 205-210, 2014;

177. Todut, C., Dan, D., Stoian, V. Numerical and experimental investigation on seismically damaged, COMPOSITE STRUCTURES, Volume 119, Pages: 648–665, 2014;
178. Todut, C., Dan, D., Stoian, V. Theoretical and experimental study on precast reinforced concrete wall panels subjected to shear force, ENGINEERING STRUCTURES Volume: 80, Pages: 323–338, 2014;
179. Tokar, A., Negoitescu, A., Adam, M. et al. Research on Mechanical Strength of Technological Fluid Storage Tank Made of Polyester Resin Reinforced with Fiberglass, MATERIALE PLASTICE, Volume: 51, Issue: 4, Pages: 432–434, 2014;
180. Totorean, A.F., Bosioc, I.A., Bernad, S.A., Susan-Resiga, R.F. Identification and visualization of vortices in by-pass graft flow, PROCEEDINGS OF THE ROMANIAN ACADEMY SERIES A-MATHEMATICS PHYSICS TECHNICAL SCIENCES INFORMATION SCIENCE Volume: 15, Issue: 1, Pages: 52–59, 2014;
181. Ungurean, M., Csanadi, Z., Gubicza, L., Peter, F. An Integrated Process of Ionic Liquid Pretreatment and Enzymatic Hydrolysis of Lignocellulosic Biomass with Immobilised Cellulase, BIORESOURCES, Volume: 9, Issue: 4, Pages: 6100–6116, 2014;
182. Vancea, C., Lazau, I. Glass foam from window panes and bottle glass wastes, CENTRAL EUROPEAN JOURNAL OF CHEMISTRY, Volume: 12, Issue: 7, Pages: 804–811, Special Issue: SI, 2014;
183. Vatau, D., Musuroi, S., Barbulescu, C., Babescu, M. PV systems modelling and optimal control, NERGY CONVERSION AND MANAGEMENT, Volume: 84, Pages: 448–456, 2014;
184. Velescu, C., Popa, N. C. Laminar Motion of the Incompressible Fluids in Self-Acting Thrust Bearings with Spiral Grooves, The Scientific World Journal, ISSN 1537-744X, Article ID 478401, 10 pages, (FI = 1,73), 2014;
185. Vica, M., Popa, M., Dumitreț, G.A., Glevitzky, M., Todoran, A. Study on Microbiological Quality And Pollution Control of Groundwater from Different Areas in the Alba County, Romania, JOURNAL OF ENVIRONMENTAL PROTECTION AND ECOLOGY, Volume: 15, Issue: 1, Pages: 64–72, 2014;
186. Vica, M.L., Glevitzky, M., Dumitreț, G.A., Junie, L.M., Popa, M. Antibacterial activity of different natural honeys from Transylvania, Romania, JOURNAL OF ENVIRONMENTAL SCIENCE AND HEALTH PART B-PESTICIDES FOOD CONTAMINANTS AND AGRICULTURAL WASTES, Volume: 49, Issue: 3 Pages: 176–181, 2014;
187. Vida, M., Lupse, O., Gomoj, V., Stoicu-Tivadar, L., Stoicu-Tivadar, V., Bernad, E. Using Web Services to support the interoperability between healthcare information systems and CDS systems, CONTROL ENGINEERING AND APPLIED INFORMATICS, Volume: 16, Issue: 1, Pages: 106–113, 2014;
188. Zaharia R., Dubina D. "Fire design of concrete encased columns: Validation of an advanced calculation model, STEEL AND COMPOSITE STRUCTURES, Vol. 17, No. 6, 2014.

ISI Proceedings

ISI Proceedings

1. Aldea, C.C., Olariu, C. Selecting the optimal software solution under conditions of uncertainty, 2nd World Conference on Business, Economics and Management (BEM) Location: Antalya, TURKEY, Book Series: Procedia Social and Behavioral Sciences, Volume: 109, Pages: 333-337, 2014;
2. Anastasiadis, A.S., Mosoarca, M., Mazzolani, F.M. Cyclic and Strain Rate Local, 7th European Conference on Steel and Composite Structures, EuroSteel 2014, Napoli, Italia, 10-12 septembrie 2014, pp. 599-600 – Abstract volume, ISBN: 978-92-9147-121-8; 2014;
3. Andreescu, I., Gaivoronschi, V., Micle, D., Vuicin, L., Mosoarca, M. The Hidden Landscape. Complex Assesment of the Historic Park of Banloc, Romania, RICH 2014 (RICH 2014 – Robotics: Innovation for Cultural Heritage), Venetia, Italia, 2014;
4. Andreescu, I., Gaivoronschi, V. The Banloc Castle. The rebirth of a landscape park, 2nd International conference on Protection of historical constructions, PROHITECH'14, Antalia, Turcia, 2014;
5. Ardelean, E; Ardelean, M; Harau, C; Crisan, E, Researches on the production of self-reducing briquettes from waste containing iron and carbon, INTERNATIONAL CONFERENCE ON APPLIED SCIENCES, Wuhan, 5 pag., 2014;
6. Ardelean, E, Ardelean, M., Josan, A., Pinca-Bretotean, C. Contribution on the influence of steel ladle processing (LF) upon the nitrogen removal rate, INTERNATIONAL CONFERENCE ON APPLIED SCIENCES, Wuhan, 5 pag., 2014;
7. Baba, M., Lascu, C., Boldea, I. et al. Parallel and series 4 Switch Z-Source converters in induction motor drives. IEEE Conference: International Conference on Optimization of Electrical and Electronic Equipment (OPTIM) Location: ROMANIA, Date: MAY 22-24, 2014, Pages: 639-646, 2014;
8. Balint, C., Budura, G. System Model for Performance Evaluation VAMOS Downlink Transmission. IEEE Conference: International Conference on Optimization of Electrical and Electronic Equipment (OPTIM) Location: ROMANIA Date: MAY 22-24, 2014, Pages: 796-801, 2014;
9. Bordeasu, I., Popoviciu, M. O., Mitelea, I., Ghiban, B., Ghiban, N., Sava, M., Duma, S. T., Badarau, R. Correlations between mechanical properties and cavitation erosion resistance for stainless steels with 12% Chromium and variable contents of Nickel, Conference: International Conference on Applied Sciences, China, Book Series: IOP Conference Series–Materials Science and Engineering, Volume: 57, Article Number: 012006, 2014;
10. Bordeasu, I., Popoviciu, M. O., Mitelea, I., Ghiban, B., Ghiban, N. Cavitation erosion resistance of two steels with the same percentage of Chromium and Nickel but different Carbon content, International Conference on Applied Sciences Book Series: IOP Conference Series–Materials Science and Engineering, Volume: 57, Article Number: 012007, 2014;
11. Bordeasu, I., Mitelea, I., Jurchela, A. D., Oanca, O. Microstructure and cavitation erosion resistance for stainless steels with 12 % CHROM and variable Nickel concentrations, Conference: 22nd International Conference on Metallurgy and Materials (METAL), Brno, CZECH REPUBLIC, Pages: 742-747, Published: 2014;
12. Bordeasu, I., Oanca, O., Mitelea, I., Craciunescu, C. Phenomenology of degradation by cavitation for heat treated Cu-Al-Ni-Fe Bronzes, Conference: 22nd International Conference on Metallurgy and Materials (METAL), Brno, CZECH REPUBLIC, pages: 1561-1566, Published 2014;
13. Chioreanu, C. Upon Power Loses Due to Current Harmonics in a Fotovoltaic System, Opperating at Maximum Power Point, International Conference on Materials Science, Machinery and Energy Engineering, Location: Hong Kong, PEOPLES R CHINA, Book Series: Advanced Materials Research, Volume: 853, Pages: 352-357, Published: 2014;
14. Chioreanu, C.; Babescu, M., On Optimal Functioning of the Aeolian Electro-Power Systems, International Conference on Materials Science, Machinery and Energy Engineering, Location: Hong Kong, PEOPLES R CHINA, Book Series: Advanced Materials Research, Volume: 853, Pages: 345-351, Published: 2014

15. Davidescu, C.M., 15th International Conference on Polymers and Organic Chemistry (POC-2014) Preface, PURE AND APPLIED CHEMISTRY, Volume: 86, Issue: 11, Pages: 1619-1619, Published: NOV 2014;
16. Demetrescu, B., Isopescu, B., Mosoarca, M. A Study of Retrofitting Traditional Shingles and Shakes Roofs on Historical Buildings, PROHITECH'14 – Proceedings of 2nd International Conference on Protection of Historical Constructions, 7-9 mai 2014, Antalya, Turcia, ISBN NUMBER: 9789755183619, pp.95-99, 2014;
17. Dobra, A. Technical Education: Digital And Analogical Aspects Of Communication, Conference: 3rd World Conference on Educational Technology Researches (WCETR) Location: Antalya, TURKEY, Book Series: Procedia Social and Behavioral Sciences, Volume: 131, Pages: 426-431, Published: 2014;
18. Draganescu, G.E., Todea, C. New signal analysis methods for laser Doppler flowmetric recordings, 5th International Conference on Lasers in Medicine – Biotechnologies Integrated in Daily Medicine Location: Timisoara, Book Series: Proceedings of SPIE, Volume: 8925, Article Number: 89250M, Published: 2014;
19. Draghici, A. Albulescu, C.T. Tamasila, M. Entrepreneurial attitude as knowledge asset: its impact on the entrepreneurial activity in Europe, 2ND WORLD CONFERENCE ON BUSINESS, ECONOMICS AND MANAGEMENT, Antalya, 5 pag., Published 2014;
20. Duran, V. Gogan, L. M., Financing of a Business, în A. I. Iacob (Ed.), 2nd World Conference on Business, Economics and Management, (BEM), Procedia, Social and Behavior Sciences Journal (ISSN 1877 - 0428), vol. 109, pp. 375 - 379, January 2014;
21. Duran, V., Popescu, A. D. The challenge of multicultural communication in virtual teams, în Andreea Iluzia Iacob (editor), 2nd World Conference on Business, Economics and Management (BEM), Procedia Social and Behavior Sciences Journal (ISSN 1877-0428), Volume 109, pp. 365-369, Published 2014;
22. Filipovici, A., Mnerie, A.V., Badescu, D., Bota, M., Maris, S., Baesu, V.; Slavici, T.; Ungureanu, D. Agribusiness Projects Assessment Using Cost-Benefit AnalyseS, 42nd International Symposium on Agricultural Engineering Location: Opatija, CROATIA Date: FEB 25-28, 2014, Book Series: Actual Tasks on Agricultural Engineering-Zagreb, Volume: 42, Pages: 439-445, Published: 2014;
23. Frigura-Iliasa, F.M., Rancov, S., Bungescu, S.T. Automatic Control Of A Cereal Conveyor Bands, 42nd International Symposium on Agricultural Engineering Location: Opatija, CROATIA Date: FEB 25-28, 2014, Book Series: Actual Tasks on Agricultural Engineering-Zagreb, Volume: 42, Pages: 327-334, Published: 2014;
24. Ghera, C.R., Mitelea I., Bordeasu, I., Oanca O. V. Reduction of Cavitation Erosion of the Bronze CuAl10ni5fe 2.5mn1 By Laser Treatment, Conference: 22nd International Conference on Metallurgy and Materials (METAL), Brno, CZECH REPUBLIC, Date: MAY 21-23, 2014;
25. Gogan, M. L., Popescu, A. D., Duran, V. Misunderstandings between cross-cultural members within collaborative engineering teams, 2nd World Conference on Business, Economics and Management (BEM), Procedia – Social and Behavior Sciences Journal (ISSN 1877 - 0428), vol. 109, pp. 370-374, Published 2014;
26. Halbac-Cotoara-Zamfir, R., A View on Land Degradation and Desertification Issues, 42nd International Symposium on Agricultural Engineering Location: Opatija, CROATIA Date: FEB 25-28, 2014, Book Series: Actual Tasks on Agricultural Engineering-Zagreb, Volume: 42, Pages: 25-33, Published: 2014;
27. Halbac-Cotoara-Zamfir, R. Changes in Agricultural Water Demands for Western Romania, 42nd International Symposium on Agricultural Engineering Location: Opatija, CROATIA, Date: FEB 25-28, 2014, Book Series: Actual Tasks on Agricultural Engineering-Zagreb, Volume: 42, Pages: 35-45, Published: 2014;
28. Holotescu, C., Cretu, V., Grosseck, G. Microblogging architecture and scenarios for learning in mobile groups. Procedia - Social and Behavioral Sciences, Volume 143, 14 August 2014, Pages 1158–1163. 3rd Cyprus International Conference on Educational Research, CY-ICER 2014, 30 January – 1 February 2014, Lefkosa, North Cyprus; 2014;

29. Holotescu, C., Cretu, V., Grosseck, G., Danciu, E. The power of the three words and one acronym: OER vs OER, 6th World Conference on Educational Sciences (WCES), Malta, Procedia - Social and Behavioral Sciences Elsevier ScienceDirect, ISSN 1877-0428, Published 2014;
30. Holotescu, C., Grosseck, G., Cretu, V., Naaji, A. Integrating MOOCs in Blended Courses. 10th International Scientific Conference eLearning and Software for Education, Bucharest, ROMANIA, ISSN 2066 - 026X, Published 2014;
31. Holotescu, C., Perifanou, M., Andone, D., Grosseck, G. Exploring OERs and MOOCs for Learning of EU Languages. Proceedings of the International Conference SMART 2014 - Social Media in Academia: Research and Teaching, Sept, Timisoara, Romania, 2014;
32. Holotescu, C., Pepler, G. Opening up education in Romania. Proceedings of the International Conference SMART 2014 - Social Media in Academia: Research and Teaching, Sept, Timisoara, Romania, 2014;
33. Jordan, A.E. Panoiu, M, A new approach in the design of an interactive environment for teaching Hamiltonian digraphs, Proceedings of INTERNATIONAL CONFERENCE ON APPLIED SCIENCES, Wuhan, 7 pag., 2014;
34. Macaveiu, A., Nafornta, C., Isar, A., Campeanu, A., Nafornta, I. A Method for Building the Range-Doppler Map for Multiple Automotive Radar Targets, 11th International Symposium on Electronics and Telecommunications (ISETC), 2014, 14-15 Nov. 2014, Timisoara, Romania, pp. 151-156, ISBN 978-1-4799-7266-1 IEEE Xplore, 2014;
35. Mateas, M., Gheorghiu, I. Consideration about objective measurement in the study of the individual resilience, 2nd World Congress on Resilience/ From Person to Society Location: Timisoara, ROMANIA Date: MAY 08-10, 2014, Pages: 1065-1069, Published: 2014;
36. Mischie, S. On Acoustic Source Localization in a Reverberant Environment based on Image Method, IEEE Conference: International Conference on Optimization of Electrical and Electronic Equipment (OPTIM) Location: ROMANIA Date: MAY 22-24, 2014, Pages: 886-891, Published: 2014;
37. Mitelea, I., Bordeasu, I., Katona, S.E. Influence of the Solution Treatment Temperature Upon The Cavitation Erosion Resistance for 17-4 PH Stainless Steels, Conference: 22nd International Conference on Metallurgy and Materials (METAL), Brno, CZECH REPUBLIC, Pages: 208-213, Published 2014;
38. Mnerie, A. V., Mnerie, D., Huțanu, A., Mnerie, G. V. Wired electrical erosion of hard and superhard metal components of agricultural equipment, Proceedings of the 42 International Symposium on Agricultural Engineering "Actual Tasks on Agricultural Engineering", Opatija, Croatia, 25-28 February 2014, ISSN 1848-4425, pg. 77-82; 2014; Published 2014;
39. Mosoarca, M., Gioncuț, V., Anastasiadis, A., Petrus, C. Applications of the Consolidation Methods Developed in the "PROHITECH" Research Program. Consolidation of Historic Wood Churches from Banat Seismic Region, Romania, PROHITECH'14 - Proceedings of 2nd International Conference on Protection of Historical Constructions, 7-9 mai 2014, Antalya, Turcia, ISBN NUMBER: 9789755183619, pp.681-687, Published 2014;
40. Mosoarca, M., Gioncuț, V., Anastasiadis, A., Petrus, C. Seismic Failure Modes Developed by Romanian Orthodox Churches, PROHITECH'14, Proceedings of 2nd International conference on Protection of Historical Constructions, 7-9 mai 2014, Antalya, Turcia, ISBN NUMBER: 9789755183619, pp.837-842, Published 2014;
41. Mosoarca, M., Andreescu, I. Seismic Vulnerability Assessment of Historical Masonry Complex Buildings of Banat Region, Romania, PROHITECH'14 - Proceedings of 2nd International conference on Protection of Historical Constructions, 7-9 mai 2014, Antalya, Turcia, ISBN: 9789755183619, pp. 846-849, Published 2014;
42. Mosoarca, M., Petrus C., Stoian V., Anastasiadis, A. Seismic risk of buildings with RC frames and masonry infills from Timisoara, Banat Region, Romania, 9th International Mansony Conference in Guimaraes, Portugalia, 2014, pp: 512, Paper ID MIE6, ISBN 978-972-8692-85-8; 2014;

43. Mosoarca M., Anastasiadis A., Petrus C., "Structural analysis of synagogues from Timisoara, Romania", Proc. 9th International Conference on Structural Analysis of historical Constructions, SAHC 2014, Program & abstracts, ISBN 042014102011495500102, pp. 120, Mexico City, Mexic, 15-17 Octombrie 2014; Published 2014;
44. Naforrita, C., Isar, A. Wavelet Based Contrast Enhancement for Still Images, 11th International Symposium on Electronics and Telecommunications (ISETC), 2014, 14-15 Nov. 2014, Timisoara, Romania, pp. 265-268, ISBN 9781479972661;
45. Naforrita, C., Isar, A. Estimating directional smoothness of images with the aid of the hyperanalytic wavelet packet transform, Signals, Circuits and Systems, International Symposium on IEEE Xplore, Iasi, Romania, ISBN 9781479931934 , Published 2014;
46. Naforrita, C., Isar, A., Nelson, J. D. B. Regularised, semi-local Hurst estimation via generalised lasso and dual-tree complex wavelets" IEEE International Conference on Image Processing ICIP 2014, Paris, France, pp. 2689-2693, ISBN: 9781479957507, Publishe 2014;
47. Naforrita, C., Macaveiu, A., Iasar, A., Naforrita, I., Campeanu, A. Envelope Detector with Denoising to Improve the Detection Probability, May 29-31, 2014, Bucharest, 10th International Conference on Communications, COMMUNICATIONS 2014 IEEE Xplore, pp 59-64, Publishe 2014;
48. Negru, R; Marsavina, L; Filipescu, H, Evaluation of generalized MTS criterion for mixed-mode fracture of polyurethane materials, ADVANCES IN FRACTURE AND DAMAGE MECHANICS XII, Sardinia, 4 pag., Published 2014;
49. Partene, E., Stoian, V., Mosoarca, M., Fekete-Nagy, L. Cyclic in-plane experimental tests for evaluation of shear capacity of brick masonry walls, 9th International Masonry Conference in Guimaraes, Portugalia, 2014, pp. 395, Paper ID 1621, ISBN 9789728692858, Published 2014;
50. Panoiu, M., Panoiu, C., Iordan, A., Ghiormez, L. Artificial neural networks in predicting current in electric arc furnaces, INTERNATIONAL CONFERENCE ON APPLIED SCIENCES, Wuhan, 7 pag., Published 2014;
51. Popescu, A. D., Suciu, S., Raoult M.G. Intercultural competences in collaborative teams, 7th International Conference on Interdisciplinary in Engineering, (INTER-ENG Conference) Procedia Technology Journal, ISSN 2212-0173, Vol. 12/2014, pp. 577-582, Published 2014;
52. Precup, R.E.; Radac, M.B., Dragos, C.A., Preitl, S., Petriu, E.M. Model-Free Tuning Solution for Sliding Mode Control of Servo Systems, 8th Annual IEEE Systems Conference (SysCon), Ottawa, CANADA Date: MAR 31-APR 03, 2014, 2014 8TH ANNUAL IEEE SYSTEMS CONFERENCE (SYSCON) Book Series: Annual IEEE Systems Conference, Pages: 30-35, Published: 2014;
53. Salcianu L., Bordeasu I., Mitelea I., Micu L. M. Cavitation Erosion Resistance of some Stainless Steels after Mechanical Hardening, Conference: 22nd International Conference on Metallurgy and Materials (METAL), Brno, CZECH REPUBLIC, Date: MAY 21-23, 2014; Published 2014;
54. Socalici, A., Popa, E., Heput, T., Vilceanu, L. Contributions related to the control of steel ingot solidification, INTERNATIONAL CONFERENCE ON APPLIED SCIENCES, Wuhan, 5 pag., Published 2014;
55. Socalici, A., Popa, E., Heput, T., Putan, V. Contributions to steel semi-finished parts quality improvements, INTERNATIONAL CONFERENCE ON APPLIED SCIENCES, Wuhan, OCT, 4 pag., Published 2014
56. Stratul, SI; Sinescu, C; Negrutiu, M; de Sabata, A; Rominu, M; Ogodescu, A; Rusu, D, On the reliability of the holographic method for measurement of soft tissue modifications during periodontal therapy, FIFTH INTERNATIONAL CONFERENCE ON LASERS IN MEDICINE: BIOTECHNOLOGIES INTEGRATED IN DAILY MEDICINE, Timisoara, 7 pag., Published 2014;
57. Tucu, D., The behaviour of willow stems by cutting in nurseries, Actual Tasks on Agricultural Engineering, Proceedings, Opatija, Croatia, ISSN 13332651, p. 405-413, Published 2014;
58. Tucu, D., Filipovici, A., Controlled stems cutting module for SRC Nurseries, Actual Tasks on Agricultural Engineering, Proceedings, Opatija, Croatia, ISSN 13332651, p. 397-404, Published 2014;

59. Turc, C.G., Belgiu, G., Carausu, C. Modular Tooling System for Ultrasonic Assisted Cutting, MODERN TECHNOLOGIES IN INDUSTRIAL ENGINEERING, Sinaia, Romania, 5 pag., Published 2014;
60. Turc, C.G; Belgiu, G. Fuzzy Logic Applications in Flanges Manufacturing, MODERN TECHNOLOGIES IN INDUSTRIAL ENGINEERING, Sinaia, Romania, 5 pag., Published 2014;
61. Tutelea, L. N., Boldea, I., Deaconu, S. I. Parameter Optimal Identification of Dual Three Phase Stator Winding Induction Machine, IEEE Conference: International Conference on Optimization of Electrical and Electronic Equipment (OPTIM) Location: ROMANIA Date: MAY 22-24, 2014, Pages: 231-238, Published: 2014;
62. Tutelea, L., Moldovan (Popa), A.; Boldea, I. 50/100 kW, 1350-7000 rpm (600 Nm peak torque, 40 kg) PM assisted Reluctance synchronous machine: optimal design with FEM validation and vector control, IEEE Conference: International Conference on Optimization of Electrical and Electronic Equipment (OPTIM) Location: ROMANIA Date: MAY 22-24, 2014 Pages: 276-283, Published: 2014
63. Ursu, D., Shamsi, P., Fahimi, B., Boldea, I. 5 phase BLDC-MRM: Design, Control, FEA and Steady-State Operation Experiments.; IEEE Conference: International Conference on Optimization of Electrical and Electronic Equipment (OPTIM) Location: ROMANIA Date: MAY 22-24, 2014 Pages: 354-361, Published: 2014;
64. Vasii, R., Andone, D., Mocofan, M., Holotescu, C. Using Web2.0 for higher education teacher training in Romania. Proceedings of the International Conference SMART 2014 - Social Media in Academia: Research and Teaching, Sept, Timisoara, Romania, 2014;
65. Zmiyevskiy Y, Mnerie A.V., Mnerie D., Totorean A.F., Researches for capitalization at a higher quality of the whey, 42th International Symposium "Actual Tasks on Agricultural Engineering", Opatija, February 2014, ISSN 1848-4425, pg. 231-240; 2014;

Books

1. Ancuti, M.C. Masini si actionari electrice. Aplicatii, Editura Orizonturi Universitare, 2014, ISBN 9789736385711;
2. Badea, C. Tehnologia Constructiilor Civile si Industriale, Editura Eurostampa, Timisoara, 2014, ISBN 9786065698628;
3. Bancea, O., Adam, M. Tehnica masurarii si reglarii in instalatiile de ventilare si climatizare, Editura Politehnica, 2014, ISBN 9786065547896;
4. Banciu, F. V. Ghid de lucrări practice și aplicații pentru proiectarea echipamentelor tehnologice. Design-ul dispozitivelor, Editura Politehnica Timisoara, 2014, ISBN 9786065548497;
5. Banciu, F.V. Ghiduri de bune practici-didactica predării disciplinei asamblari mecanice, Editura Matrix Rom, 2014, ISBN 9786062500344;
6. Banciu, O., Adam, M. Tehnica măsurării și reglării în instalațiile de ventilare și climatizare. Teorie și aplicații, Editura Politehnica Timisoara, 2014, ISBN 9786065547896;
7. Barbulescu C., Kilyeni S., Chapter title: Particle Swarm Optimization Techniques: Benchmarking and Optimal Power Flow Applications, pp. 141-153, Book title: Issues and Challenges in Artificial Intelligence, Studies in Computational Intelligence, Editors: Z. S. Hippe et al., Springer International Publishing Switzerland 2014, ISBN 9783319068824;
8. Belea, G., Mirea, M. Grafică asistată de calculator și desen ethnic. Aplicații, Editura Politehnica Timisoara, 2014, ISBN 9786065544406;
9. Boldea, I. Transformatoare și mașini electrice, Editura Politehnica Timisoara, 2014, ISBN 9789736259432;
10. Branea A. M., Găman, M.S. Student Trends. Numărul IV 2010 – 2011, Editura Politehnica Timisoara, 2014, ISBN 9786065548572;
11. Buchman, I., Badea, C. Verificări frecvente ale caracteristicilor materialelor de construcții uzuale, Editura Politehnica Timisoara, 2014, ISBN 9786065541429;
12. Bucos, M. Programată orientată pe obiecte, Editura Politehnica Timisoara, 2014, ISBN 9786065548510;
13. Bucos, M. Sisteme de baze de date relaționale, Editura Politehnica Timisoara, 2014, ISBN 9786065548527;
14. Cernicova-Bucă, M. Timișoara 1989: vocile orașului, Editura Eurostampa, Timisoara, 2014, ISBN 9786065699236;
15. Cernicova, M, Dejica, D. Dictionar de comunicare și relații publice, român-englez. 271 pag. Cluj: Casa Cartii de Stiinta, 2014, ISBN 9786061706389, Timișoara: Orizonturi Universitare, 2014, ISBN 9789736385766;
16. Ciurdariu, L. Analiză matematică. Calcul integral. Culegere de problem, Editura Politehnica Timisoara, 2014, ISBN 9786065546387;
17. Constantin, E. C. Managementul comunicării în programe cu finanțare europeană, Editura de Vest, 2014, 243 pagini, ISBN 9789733606086;

18. Dăianu, D. Mathematical Analysis. Differential Calculus, Editura Politehnica, Col. Matematici moderne, Timișoara, 2014, 492 pagini, ISBN 9786065548701;
19. David, I. Hidraulica I, II, Tipografia Timisoara, ISBN 9789736256141, 2014;
20. Dascăl, A., Florian, I. Controlul și reducerea poluării la autovehiculele rutiere, Editura PIM, Iasi, 2014, ISBN 9786061321100;
21. Davidescu, C. M. Peter, F., Ilia, G. (Editors). Book of Abstracts. 15th International Conference Polymers and Organic Chemistry, June 10-13, Timișoara, România, Editura Politehnica Timisoara, 2014, ISBN 9786065548411;
22. Dehelean, L.M., Dehelean, N.M. Desen Tehnic si Inginerie Mecanica pentru ETc, Editura Eurostampa, 2014, ISBN 9786065697744;
23. Dejica, D., Cernicova, M. Dictionar de comunicare și relații publice, englez-român. 279 pag. Cluj : Casa Cartii de Stiinta: ISBN 9786061706396, Timișoara: Orizonturi Universitare, 2014, ISBN 9789736385759;
24. Dejica, D., Popescu-Mitroi, M., Dragomir, G. M. Dicționar englez-român, român-englez cu termeni și expresii utilizate in domeniul egalității de șanse și tratament. Ediția a 2-a. Timișoara: Editura Politehnica, 2014, 250 pag. ISBN 9786065547575;
25. Diniș, C.M. Măsurări electrice și electronice. Tehnica măsurării. Teme experimentale, Editura Politehnica, Timisoara, ISBN 9786065548282;
26. Dragomir, G. M., Todorescu, L. L. (coord.), Grosseck, G., Holotescu, C., Mazilescu, C. A., Popescu Mitroi, M., Vrgovici, S. M. Repere in evaluare. Editura de Vest, 2014, ISBN 9789733606031;
27. Dubina, D., Landolfo, R., Stratan, A., Vulcu, C. [Editors], Application of High Strength Steels in Seismic Resistant Structures, Editura Orizonturi Universitare, Timisoara, 2014, ISBN 9789736385520;
28. Floruț, S. C. Reinforced concrete slabs streinghened using FRP composites, Editura Politehnica, Timisoara, 2014, ISBN 9786065547704;
29. Gaivoronschi, V., Graf, R., Hedesan, O., Miclaus, M., Novicov, R., Toma, C. 50/60 – Proiectul 50/60. Universitatea de Vest din Timisoara, Editura Universitatii de Vest, 2014, ISBN 9789731252636;
30. Găman, M.S., Branea, A. M. Student Trends. Numărul V 2011 – 2012, Editura Politehnica, Timisoara, 2014, ISBN 9786065548589;
31. Golet, I, Hedrea, C, Petrisor, C. Analiza Matematica Sinteze teoretice si aplicatii, Editura Politehnica Timișoara, 270 pag, 2014, ISBN 9786065548688;
32. Herman, M. Sisteme și tehnologii de transport, Editura Politehnica, Timisoara, 2014, ISBN 9786065548770;
33. Herman, R., Olariu, M., Crainic, N., Reviczky-Levay, A., Vasilescu, M., Tulcan, L., Mălaimare, G., Safta, V., Han, A. Aplicații specifice în tehnologia materialelor, Editura Politehnica Timișoara, 2014, ISBN 9789736258145;
34. Herman, M., Stepan, D. S. Interoperabilitatea rețelelor de transport, Editura Politehnica Timișoara, 2014, ISBN 9786065548398;
35. Hlușcu, M., Tripa, P. Rezistența Materialelor I, Editura Mirton, România, 2014, ISBN 9789735214753;

36. Ianchiș, D., Căleanu, C. D. Practical aspects of embedded systems, Editura Politehnica, Timisoara, 2014, ISBN 9786065548138;
37. Irimia, D. D., Blaj, C. Câmpuri și unde electromagnetice. Ed. revizuită și adăugită, Editura Politehnica, Timisoara, 2014, ISBN 9786065548442;
38. Ionel, S. Electronică pentru inginerii mecanici, Editura Politehnica, Timișoara, 2014, ISBN 9786065547407;
39. Iures, L. Materials Science - Laboratory Work, Editura Eurostampa, Timisoara, 2014, ISBN 9786065697584;
40. Jigoria-Oprea, D., Barbulescu, C., Simo, A. Utilizarea si programarea calculatoarelor. Lucrari practice. Vol. 1. Editia 2, Editura Orizonturi Universitare, 2014, ISBN 9789736385698;
41. Kovacs, A., Bundău, O., Căplescu, C. Matematici special. Culegere de problem, Editura Politehnica Timișoara, 2014, ISBN 9786065547568;
42. Lazăr, I. C. Linear algebra, analytische geometric, kurven unflächen, Editura Politehnica, Timișoara, 2014, ISBN/ISSN, 9786065547643;
43. Linul, E., Marsavina, L. Mechanical Characterization of Rigid PUR Foams Used for Wind Turbine Blades Construction, World Academic Publishing, China, 2014, ISBN 23069325;
44. Lupa, N. Comportări asimptotice exponențiale pentru operatori de evoluție în spații Banach, Editura Politehnica, Timișoara, 2014, ISBN, 9786065548763;
45. Lupa, L., Popa, A., Iliă, G. Use of Phosphorus - Containing Polymers for the Removal of Metal Ions from Wastewaters in "Phosphorus - Based Polymers: From Synthesis to Applications, Royal Soc Chemistry, United Kingdom, 2014, ISBN 9781849736466;
46. Magda, A., Costea, L. V. Noțiuni teoretice de chimie generală, Editura Politehnica, Timișoara, 2014, ISBN 9786065548541;
47. Man, E. T. Drenaje, vol. 1, ISBN 9789736385667 (576 pag.) si vol. 2, ISBN 978973638-674 (384 pag), Editura Orizonturi Universitare, Timisoara, 2014;
48. Manea, F. Electrochemical Techniques for Characterization and Detection Application of Nanostructured Carbon Composite, InTech, Rijeka, Croatia, 2014, ISBN 9789535115861;
49. Manea, F., Pop, A. Water Treatment, InTech, Rijeka, Croatia, 2014, ISBN 97995330710885;
50. Manea, F., Pop, A. Decontamination of wastewaters containing organics by electrochemical methods, InTech, Rijeka, Croatia, 2014, ISBN 978953510928;
51. Menyhardt, K., Nagy, R., Luca, G. Mecanica. Dinamica. Teorie si aplicatii, Editura Politehnica, Timisoara, 2014, ISBN 9786065547599;
52. Miclăuș, M., Ghenciulescu, S., Ilin, C., Blidariu, C., Kisilewicz, I., Luca, A., Stan, S. 2793 Grădina cu vise, Editura Partoș, România, 2014, ISBN 9789730170887;
53. Miheț-Popa, L. Modelare și simulare în MATLAB și simulink cu aplicații în inginerie electrică, Editura Politehnica, Timișoara, 2014, ISBN 9786065548237;

54. Miheț-Popa, L. Development of simulation tools for distributed energy conversion systems towards Smart Grids. Habilitation thesis, Editura Politehnica Timisoara, 2014, ISBN 9786065548855;
55. Miheț-Popa, L., Ancuți, M. C. Algoritmi de simulare în inginerie electric. Aplicații practice, Editura Politehnica, Timișoara, 2014, ISBN 9786065548299;
56. Miheț-Popa, L., Groza, V. Control strategies of DER components using energy storage systems and actively controlled loads, InTech, Austria, 2014, ISBN 9789535141105;
57. Mitelea, I., Uțu, I. D. Selecția, utilizarea și reciclarea materialelor ingineresti, Editura Politehnica, Timișoara, 2014, ISBN 9786065548664;
58. Mușuroi, S. Contributions to the Optimal Structures of the Electromechanical Systems and the Electric Power Quality, Editura Eurostampa, 2014, ISBN 9786065699328;
59. Mușuroi, S. Mașina de inducție alimentată prin convertoare statice de frecvență, Editura Eurostampa, 2014, ISBN 9786065698154;
60. Osaci, M., Jitian, S. Fizică generală, Editura Politehnica, Timișoara, 2014, ISBN 9786065548114;
61. Pănoiu, M., Iordan, A. E. Programare orientată pe obiecte în C++, Editura Politehnica, Timișoara, 2014, ISBN 9786065548305;
62. Petri, D., Belega, D., Dallet, D. Dynamic testing of analog-to-digital converters by means of the sine-fitting algorithms, in Carbone, P; Kiaei S; Xu, F (Editors), Design, Modeling and Testing of Data Converters, pp. 309-340, Springer Berlin Heidelberg, Germany, 2014,; Capitol in carte publicata la Editura Springer, 2014, ISBN 9783642396557;
63. Pop, N. Fizică. Elemente fundamentale pentru ingineri, Editura Politehnica, Timișoara, 2014, ISBN 9786065547391;
64. Popa, S., Boran, S. Politici și strategii globale de securitate alimentară, Editura Politehnica, Timișoara, 2014, ISBN 9786065541436;
65. Preluscek, E., Gîrbaciu, C. Tehnologia lucrărilor de construcții hidrotehnice, Editura Politehnica Timișoara, 2014, ISBN 9786065547803;
66. Radoslav, R. (Coordonator). Studii urbane și de amenajare a teritoriului. Studii de cercetare coordonate de CCUPT în cadrul preselecțiilor 2013 – 2014 și a prediplomelor 2013, Editura Politehnica Timișoara, 2014, ISBN 9786065548459;
67. Robu, N. Arhitectura calculatoarelor, Editura Politehnica, Timișoara, 2014, ISBN 9738247012;
68. Sarbu, I., Valea, E. S. Transactions on Engineering Technologies, vol.275, Cap. 23: Optimization of path for water transmission and distribution systems, Springer Netherlands, 2014, ISBN 9789400776838;
69. Serban, V.A., Răduță, A., Știința și Ingineria materialelor, Ed. a III-a revizuită și adăugită. Editura Politehnica, Timișoara, 2014, ISBN 9786065540446;
70. Șimon, S. The Persuasive Function of Written Advertisements. Cluj-Napoca: Casa Cărții de Știință, ISBN 9786061706013, Timișoara: Editura Orizonturi Universitare, 2014, ISBN 9789736385704 (327 pp);
71. Socalici, A., Miloșteanu, D. Baza energetic și de materii prime în industria de material, Editura Politehnica, Timișoara, 2014, ISBN 9786065548886;

72. Suciu, L. Repere teoretice în științele comunicării, Casa Cărții de Știință & Orizonturi Universitare, Timisoara, 2014, 9786061706006, 9789736385568;
73. Suciu, L. În căutarea sensului. De la analiza discursului la design-ul comunicării, Casa Cărții de Știință & Orizonturi Universitare, Timisoara, 2014, 9786061706020, 9789736385773;
74. Suciu, L., Kilyeni, A. Ghid de comunicare scrisă și orală, Editura Orizonturi Universitare, Timisoara, 2014, ISBN 9789736385964;
75. Surianu, F.D. Computational and numerical simulations. Chapter16: Experimental determinations and numerical simulations of the effects of electromagnetic interferences into the overhead power lines with double circuit, operating with a disconnected circuit, InTech, Austria, 2014, ISBN 9789535112204;
76. Surianu, F.D. Despre Forțele naturii și Radiația Electromagnetică, Editura de Vest, România, 2014, ISBN 9789733606116;
77. Stepan, S. D., Dungan, L. I. Instalații de control comandă și tehnica circulației, Editura Politehnica, Timișoara, 2014, ISBN 9786065547667;
78. Tamas, A., Transfer termic cu aplicatii in ingineria chimica, Editura Politehnica, Timisoara, 2014, ISBN 9786065548732;
79. Tirian, G. O. Robotică, Editura Politehnica, Timisoara, 2014, ISBN 9786065545960;
80. Tirian, G. O. Linii flexibile de fabricație robotizate, Editura Politehnica, Timisoara, 2014, ISBN 9786065541405;
81. Todorescu, L.L., Holban, N. Ghid de practica tehnologica pentru învățământul superior. Repere metodologice privind organizarea practicii tehnologice de specialitate la ciclul de licență, Editura de Vest, 2014, ISBN 9789733606213;
82. Tutelea, L. N., Deaconu, S. I., Dual rotor single stator permanent magnets motors for hybrid electric vehicles, Editura Politehnica, Timisoara, 2014, ISBN 9786065548619;
83. Tutelea, L. N., Svoboda, M., Ancuți, C. M. Tehnici de programare în C. Aplicații pentru însușirea noțiunilor de bază, Editura Politehnica, Timisoara, 2014, ISBN 9786065548640;
84. Vartolomei, M. et. al. European Research Development in Horizon 2020, Lumen Media Publishing, United Kingdom, 2014, ISBN 10: 1910129011;



Politehnica University of Timisoara



Piata Victoriei No. 2
RO 300006, Timisoara
Tel: +40 256 40 30 00
Fax: +40 256 40 30 21
Email: rector@upt.ro
www.upt.ro



EDITURA POLITEHNICA

ISSN 1841-2769