



Universitatea  
Politehnica  
Timișoara

# Research Report 2018

**Research  
Annual  
Report**

Politehnica  
University  
Timisoara

2018

# Research Report 2018

Research Report, 2018  
The third edition of Research Report, revised and expanded.

Copyright © Editura Politehnica 2019

All rights reserved to Politehnica University Timisoara.

No part of this booklet may be reproduced or transmitted in any form or by any means, electronic or mechanical, including photocopy, recording, or any information storage and retrieval system now known or to be invented, without permission in writing from the publisher, except by a reviewer who wishes to quote brief passages in connection with a review written for inclusion in a magazine, newspaper, or broadcast.

## Editorial team

Editor:  
Assoc.Prof. Liviu Ioan CĂDARIU-BRĂILOIU, PhD

Co-Editors:  
Agnes STEPANIAN, Ladislau WALKOVSKY, Roxana Mihaela SÎRBU, Andreia Claudia LĂZĂRESCU

Layout & cover design: Eugen STAN

Editura Politehnica  
Bd. Vasile Pârvan nr. 2b  
300223 Timișoara, România  
Tel./Fax. 0256/404.677  
E-mail: editura@upt.ro

ISSN 1841-2769  
ISSN-L 1841-2769

Research  
Report 2018

**Research  
Annual  
Report**  
Politehnica  
University  
Timișoara  
2018



## Structure of the report

Introducing the Report .....	5
Research Centers .....	9
Scientific Excellence Awards .....	15
Projects supported by public funds .....	43
National Research Projects .....	45
Research and Development Projects for Young Researchers ...	117
International Research Projects .....	133
Projects supported by private funds .....	155
Patents .....	177
Granted Patents .....	181
Utility Models .....	187
Honorary Members .....	191
Doctor Honoris Causa .....	195
Honorary Professors .....	198
Habilitation Thesis .....	199
PhD Thesis .....	205
Scientific Conferences .....	213
Scientific Journals .....	225
ISI Papers .....	233
ISI Papers in highlight .....	237
Papers in ISI Journals .....	263
Papers in ISI Proceedings .....	279
Books .....	309
Books in highlight .....	313
Books List .....	317
Book Chapters List .....	323



# Introducing the Report





“It’s not the walls that make a school, but the spirit living inside.”  
King Ferdinand I, 1923

The needs for a modern society, in the context of a competitive global market, require highly skilled human resource development. In this context, the role of universities in the innovation process has increased continuously over time because the development of new products or technologies depends more and more on the findings of scientific research.

Established in 1920, shortly after the union of Romanian territories, in a European context marked by the redefinition of states and by the aftermath of World War I, the Polytechnic School in Timișoara – as it was originally called – was the answer to one of the requirements of the Romanian society of the time, namely the formation of engineers.

The mission of the Politehnica University Timișoara (UPT) is to offer nationally competitive and internationally recognized opportunities for Learning, Research, and Innovation at the highest levels of excellence. As a resource of knowledge for the public, the university builds partnerships with other educational institutions, community organizations, government agencies, and the private sector to fulfill the requirements for competences of the societal environment through superior professional training for students and graduates.

The present Research Report of Politehnica University Timișoara gathers the main results obtained through the research activities carried out within the university in 2018, Politehnica being renowned as a remarkable actor on the stage of scientific research, both at national and international level. Our research activity is facilitated by the existence of twenty-six research centres specialized in fields that are capital for the sustainable development of any modern society. Each of these research centres brings together various prestigious researchers, whom, by their effort and vision, provide UPT with the incentives needed to contribute to the progress of our society.

Most of the research activity carried out by our institution is financed through external sources, obtained either from national and international calls for projects, or through agreements with private companies. This represents a confirmation of the superior quality of the research, but also of the prestige and professional deontology of the researchers affiliated to our institution. Politehnica’s reputation as an institution of advanced research is also emphasized by the patents obtained by its researchers, by the medals and prizes obtained in both national and international competitions, and by the collaborations with important research centres and institutes from Romania and from abroad.

Each year we select the most talented young researchers for our doctoral school, providing them with the opportunity to transform their knowledge and ideas into the innovations of tomorrow. Many of them take part in peer learning programs and consolidate in this way the relationship between our university and similar partner institutions. They strive for becoming doctors in science.

This report is divided into twelve sections, each one presenting a specific component of the research activity performed within the institution.

The first section focuses on the research infrastructure, which comprises the twenty-six research centres hosted by the university. The order in which they are presented is given by the research fields. The research centres, respectively teams of researchers, on different themes, are highly important for our university since they manage to put into practice the scientific research strategy of the university successfully, within the framework of numerous grants and contracts won by competition. The research results are materialized in papers, patents and products, all bringing for the University prestige, as well as important funds.

The second section of the Research Report is dedicated to the Scientific Excellence Awards. These prestigious awards celebrate those colleagues who have made a significant contribution in their field of research and continue to inspire future generations to get involved in science.

The third and fourth sections include the research projects implemented by the university. The third section includes the projects supported by public funds, both national and international, while the fourth one includes the projects supported by private funds awarded by companies. For the purposes of this report, we have chosen the most relevant projects for our the most representative projects for our research strategy.

The innovative capacity of the Politehnica University Timișoara is supported by teachers and scientific researchers through patents and utility models invented, presented in the fifth section.

Politehnica University Timișoara recognizes scientific excellence by conferring the honorary degrees of Doctor Honoris Causa and Honorary Professor to distinguished Researchers for their contribution to the development of UPT of continuous support, as shown in section six of this Report.

Sections seven and eight include habilitation theses and PhD theses held in 2018 in our University.

Section nine presents an overview of the most relevant scientific conferences that brought together scholars and professionals from Romania and from abroad. The conferences hosted by our university encouraged the dialogue, facilitated the exchange of ideas, and offered a great opportunity for new collaborations.

The tenth section gathers the scientific journals that have been published by our institution. This category includes journals specialized in various fields, such as computer science, chemistry and environmental engineering, electronics and communications, economics and social sciences, electrical engineering, mathematics and physics, hydrotechnics, physical education and sport, modern languages, etc.

The dissemination of the research results and findings is an integral part of the research process and the career in academia. Section eleven presents the most relevant scientific researches that have been published in 2018. It comprises the results obtained by our researchers, namely the papers that obtained recognition from some of the most prestigious journals, from both Romania and abroad.

And finally the twelfth section comprises a collection of books written by our researchers, most of them published under Politehnica Publishing House.

Through research we generate ideas, through ideas we generate innovation and through innovation we contribute to the improvement of the quality of life; this is why research is our priority.

# RESEARCH CENTRES





### Research Institute for Renewable Energy

Director: prof. Viorel UNGUREANU  
Contact: viorel.ungureanu@upt.ro, <http://www.icer.ro/>



### Research Centre for Computers and Information Technology

Director: prof. Vladimir-Ioan CREȚU  
Contact: vladimir.cretu@upt.ro, <http://cercetare.cs.upt.ro/>



### Research Centre for Automatic Systems Engineering

Director: prof. Radu-Emil PRECUP  
Contact: radu.precup@upt.ro, <http://www.aut.upt.ro/centru-cercetare/>

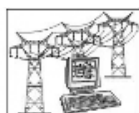

### Research Centre for Power Systems Analysis and Optimization

Director: prof. Ștefan KILYENI  
Contact: stefan.kilyeni@upt.ro, <http://www.et.upt.ro/index.php?sublink=1694&link=10&pag=2&lang=ro>



### Research Centre for Smart Energy Conversion and Storage

Director: prof. Nicolae MUNTEAN  
Contact: nicolae.muntean@upt.ro,  
<http://www.et.upt.ro/index.php?link=10&sublink=1695&pag=1&lang=en>



### Research Centre for Intelligent Electronic Systems

Director: prof. Marius OTEȘTEANU  
Contact: marius.otesteanu@upt.ro, <http://ccesi.upt.ro/>

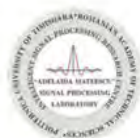

### Research Centre for Intelligent Signal Processing

Director: prof. Alexandru ISAR  
Contact: alexandru.isar@upt.ro, <http://www.tc.etc.upt.ro/ispr/>



### Research Centre for Multimedia

Director: prof. Radu VASIU  
Contact: radu.vasiu@upt.ro, <http://www.cm.upt.ro>



### Research Centre for Environmental Science and Engineering

Director: prof. Rodica PODE  
Contact: rodica.pode@upt.ro, <http://www.chim.upt.ro/ro/cercetare/centre-cercetare/centru-de-cercetare-in-stiinta-si-ingineria-mediului>



## Research Centre for Inorganic Materials and Alternative Energies

Director: prof. Ioan LAZĂU

Contact: [ioan.lazau@upt.ro](mailto:ioan.lazau@upt.ro), <http://www.chim.upt.ro/ro/cercetare/centre-cercetare/centru-de-cercetare-pentru-materiale-anorganice-si-energii-alternative>



## Research Centre for Organic, Macromolecular and Natural Compounds' Chemistry and Engineering

Director: prof. Corneliu DAVIDESCU

Contact: [corneliu.davidescu@upt.ro](mailto:corneliu.davidescu@upt.ro), <http://www.chim.upt.ro/ro/cercetare/centre-cercetare/centru-de-cercetare-in-chimia-si-ingineria-compusilor-organici-macromoleculari-si-naturali>



## Research Centre for Mechanics of Materials and Structural Safety

Director: prof. Dan DUBINĂ

Contact: [dan.dubina@upt.ro](mailto:dan.dubina@upt.ro), <http://www.ct.upt.ro/centre/cemsig/>



## Research Centre for Hidrotechnical Engineering and Enviromantal Protection

Director: prof. Constantin FLORESCU

Contact: [constantin.florescu@upt.ro](mailto:constantin.florescu@upt.ro), <http://www.ct.upt.ro/centre/cchpm/index.htm>



## Research Centre for Building Services

Director: s.l. Calin SEBARCHIEVICI

Contact: [calin.sebarchievici@upt.ro](mailto:calin.sebarchievici@upt.ro), <http://www.ct.upt.ro/centre/ccic/>



## Research Centre for Retrofitting of Constructions

Director: prof. Tamas NAGY GYORGY

Contact: [tamas.nagy-gyorgy@upt.ro](mailto:tamas.nagy-gyorgy@upt.ro), <http://www.ct.upt.ro/centre/reco/>



## Research Centre for Construction and Transportation Substructures

Director: prof. Liviu Adrian CIUTINĂ

Contact: [adrian.ciutina@upt.ro](mailto:adrian.ciutina@upt.ro), <http://www.ct.upt.ro/centre/ict/>



## Research Centre for Mechatronics and Robotics

Director: prof. Inocențiu MANIU

Contact: [inocentiu.maniu@upt.ro](mailto:inocentiu.maniu@upt.ro), <http://mctr.mec.upt.ro/activitate-de-cercetare>



### Research Centre for Medical Engineering

Director: prof. Liviu MARȘAVINA  
Contact: [liviu.marsavina@upt.ro](mailto:liviu.marsavina@upt.ro), <https://ccim.upt.ro/>



### Research Centre for Integrated Engineering

Director: prof. George DRĂGHICI  
Contact: [george.draghici@upt.ro](mailto:george.draghici@upt.ro), <http://imf.upt.ro/CCII/index.html>



### Research Centre for Processing and Characterization of Advanced Materials

Director: conf. Bogdan RADU  
Contact: [bogdan.radu@upt.ro](mailto:bogdan.radu@upt.ro), <https://sites.google.com/view/ccpcma/home>



### Research Centre for Complex Fluid Systems Engineering

Director: prof. Romeo SUSAN-RESIGA  
Contact: [romeo.resiga@upt.ro](mailto:romeo.resiga@upt.ro), <https://mh.mec.upt.ro/>



### Research Centre for Thermal Machines and Equipments, Transportation and Environmental Pollution Control

Director: prof. Ioana IONEL  
Contact: [ioana.ionel@upt.ro](mailto:ioana.ionel@upt.ro), <http://mettcp.mec.upt.ro/>



### Research Centre for Engineering and Management

Director: prof. Claudiu Tiberiu ALBULESCU  
Contact: [claudiu.albulescu@upt.ro](mailto:claudiu.albulescu@upt.ro), <http://www.mpt.upt.ro/pag/centru%20cercetare.html>



### Research Centre for Urban Planning

Director: prof. Radu RADOSLAV  
Contact: [radu.radoslav@upt.ro](mailto:radu.radoslav@upt.ro), <http://ccddt.blogspot.ro>



### Research Centre for Advanced Study Methods for Physical Phenomena

Director: prof. Dumitru TOADER  
Contact: [dumitru.toader@upt.ro](mailto:dumitru.toader@upt.ro), <http://www.et.upt.ro/ro/departaments/bazele-fizice-ale-ingineriei>



### Research Center for Materials and Industrial Technologies

Director: prof. Teodor HEPUȚ  
Contact: [teodor.heput@upt.ro](mailto:teodor.heput@upt.ro), <http://www.fih.upt.ro/ccmti/>





# SCIENTIFIC EXCELLENCE AWARDS



## Member of Romanian Academy President of Timișoara Branch of Romanian Academy Acad. Dan DUBINĂ, PhD

Professor Dan Dubină, full Member of Romanian Academy from 2015 (Corresponding Member from 2010), has elected President of Timișoara Branch of Romanian Academy in September 26<sup>th</sup> of 2018.

His research fields of excellence are Stability of Steel Structures, Lightweight Steel Structures, Behaviour of Steel Structures in Seismic Areas, Structural Steel Connections. Prof. Dan Dubină has used to be Head of the Department of Steel Structures and Structural Mechanics at the Politehnica University Timișoara from 2004 to 2016, and, from 2001, Director of Excellence Research Centre for Mechanics of Materials and Structural Safety (CEMSIG - <https://www.ct.upt.ro/centre/cemsg/>).

He has published, in his research domains more than 500 scientific papers and 50 authored books and edited volumes, and has coordinated as Guest Editor of several Special Topical Issues of Thin Walled Structures and Journal of Constructional Steel Research, both edited by Elsevier, as well as in Steel Construction, Design and Research edited by Ernst & Sohn.

From 1997, Professor Dan Dubină is member of the Executive Board of European Convention for Constructional Steelwork - ECCS, and is a member of the Technical Committees TC 7 (Cold Formed Thin Walled Sheet Steel in Building), TC 8 (Stability), TC 10 (Connections), and TC 13 (Seismic Design); in 2005/2006 was President of ECCS. He has been awarded with the ECCS European Steel Design Award twice, in 2003 at Lausanne, and 2007 at Luxembourg. From 2009, Professor Dubina represents Romania in the Coal and Steel Committee, COSCO, of the Research Fund for Coal and Steel - RFCS of European Commission.

In Romania he was awarded several times, in 2004, 2005, 2007 and 2009 with the prizes of AICPS (Romanian Association of Structural Design Engineers) for high performance designed structures and *Opera Omnia Medal*.

Professor Dan Dubina has awarded in 1992 by Romanian Academy with 1990 „*Anghel Saligny*” prize, for a series of 16 scientific articles on *stability of structures*. In 2014, the same prize, was awarded for the book „*Design of cold-formed Steel Structures*”, authors D. Dubina, V. Ungureanu, R. Landolfo, ECCS, Ernst&Sohn/Wiley-Blackwell, 2012, while in 2018, the book „*Design of Steel Structures for Buildings in Seismic Areas*”, authors R. Landolfo, F.M. Mazzolani, D. Dubina, L.S. da Silva and Mario D’Aniello, published by ECCS, Ernst&Sohn/Wiley, 2017, has received the „*Henri Coanda*” prize awarded by MLNM & Romanian Academy.



In 2005 professor Dan Dubină has been awarded by Technical University of Cluj-Napoca, Romania, with *Doctor Honoris Causa* degree, while in 2012 the Pecs University of Hungary awarded to him the *Honorary Professor* degree.

Professor Dan Dubină has lectured as Keynote or Invited Lecturer, as well as invited Reporter in International Conferences, in Universities and Scientific and/or Professional Institutions in more than 30 events in around Europe, China, Korea, Brazil, South African Republic.

22 young researchers have obtained their PhD. Degree under the coordination of Professor Dan Dubină. Some of them are actually Professors in the Department of Steel Structures and Structural Mechanics. They, and other young researchers, together with their *maestro* form the so called „Timișoara School of Steel Structures and Structural Stability, well-known around the World Community of Steel Structures.

This is the person, member of Politehnica University Timișoara Community, who actually chairs the Timișoara Branch of Romanian Academy!

## Romanian Academy Corresponding member of the Romanian Academy Prof. Radu-Emil PRECUP, PhD

Prof. Radu-Emil Precup was elected a corresponding member of the Romanian Academy in the General Assembly that took place on June 28, 2018. He is a member of the Information Science and Technology Section of The Romanian Academy.

Radu-Emil Precup was born in Lugoj, Romania, in 1963. He received the Dipl.Ing. (Hons.) degree in automation and computers from the "Traian Vuia" Polytechnic Institute of Timișoara, Romania, in 1987, the Diploma in mathematics from the West University of Timișoara, in 1993, and the Ph.D. degree in automatic systems from the Politehnica University Timișoara, in 1996.

From 1987 to 1991, he was with Infoservice S.A., Timisoara. He is currently with the Politehnica University Timișoara (UPT), Romania, where he became a Professor in the Department of Automation and Applied Informatics, in 2000, and he is currently a Doctoral Supervisor of automation and systems engineering. He is also an Adjunct Professor within the School of Engineering, Edith Cowan University, Joondalup, WA, Australia, and an Honorary Professor and a Member of the Doctoral School of Applied Informatics with the Óbuda University (previously named Budapest Tech Polytechnical Institution), Budapest, Hungary. He is currently the Director of the Automatic Systems Engineering Research Center with UPT. From 1999 to 2009, he held research and teaching positions with the Université de Savoie, Chambéry and Annecy, France, Budapest Tech Polytechnical Institution, Hungary, Vienna University of Technology, Austria, and Budapest University of Technology and Economics, Hungary. He has been an Editor-in-Chief of the International Journal of Artificial Intelligence since 2008 and he is also on the editorial board of several other prestigious journals including IEEE Transactions on Fuzzy Systems, IEEE Transactions on Cybernetics, Applied Soft Computing (Elsevier), Evolving Systems (Springer) and Cogent Engineering (Taylor & Francis).

He is the author or coauthor of more than 300 papers published in various scientific journals, refereed conference proceedings, and contributions to books. His research interests include mainly development and analysis of new control structures and algorithms (conventional control, fuzzy control, data-driven control, sliding mode control, neuro-fuzzy control, etc.), theory and applications of soft computing, computer-aided design of control systems, modeling, optimization (including nature-inspired algorithms), and applications to mechatronics systems (including automotive systems and mobile robots), embedded systems, control of power plants, servo systems, electrical driving systems. His current h-index is 42 (Google Scholar), 36 (Scopus) and 34 (Clarivate Analytics Web of Science) as of April 2019.



Prof. Precup is a corresponding member of the Romanian Academy, a member of the Technical Committee (TC) on Virtual Systems in Measurements of the Institute of Electrical and Electronics Engineers (IEEE) Instrumentation & Measurement Society, the Task Force on Autonomous Learning Systems within the Neural Networks TC of the IEEE Computational Intelligence Society, the Subcommittee on Computational Intelligence as part of the TC on Control, Robotics and Mechatronics in the IEEE Industrial Electronics Society, the Task Force on Educational Aspects of Standards of Computational Intelligence as part of the TC on Standards in the IEEE Computational Intelligence Society, the TCs on Computational Cybernetics and Cyber-Medical Systems of the IEEE Systems, Man, and Cybernetics Society, the International Federation of Automatic Control (IFAC) Technical Committee on Computational Intelligence in Control (previously named Cognition and Control), the Working Group WG 12.9 on Computational Intelligence of the Technical Committee TC12 on Artificial Intelligence of the International Federation for Information Processing (IFIP), the European Society for Fuzzy Logic and Technology (EUSFLAT), the Hungarian Fuzzy Association, and the Romanian Society of Control Engineering and Technical Informatics. He was the recipient of the Elsevier Scopus Award for Excellence in Global Contribution (2017), the "Grigore Moisil" Prize from the Romanian Academy, two times, in 2005 and 2016, for his contribution on fuzzy control and the optimization of fuzzy systems, the Spiru Haret Award from the National Grand Lodge of Romania in partnership with the Romanian Academy in 2016 for education, environment and IT and many other awards at various conferences.

## Romanian Academy Corresponding member of the Romanian Academy Prof. Liviu MARȘAVINA, PhD

The General Assembly of the Romanian Academy elected by secret vote on 21<sup>st</sup> November 2018 four titular members and five corresponding members. Prof Liviu Marșavina from Politehnica University Timișoara was among the corresponding members (<http://www.acad.ro/bdar/armembriC.php>).

Prof Liviu Marșavina has outstanding contributions in Strength of Materials, Fracture Mechanics and Fatigue, Material Testing, Experimental and Numerical Stress Analysis. He is recognized at national and international level as an expert in experimental determination of fracture mechanics parameters, numerical simulation of crack propagation and development of modern methods for estimating integrity and durability of components and structures.

His research activity was performed on international research projects at Loughborough University (UK), University of Sheffield (UK), Ghent University (Belgium), Lublin University of Technology (Poland), Slovak Academy of Science (Slovakia), Università degli Studi di Cagliari (Italy), national and international grants and research contracts with multinational companies like Rolls Royce (UK), Adidas (Germany), Continental Automotive (Romania), TRW Automotive (Romania).

Prof. Marșavina was invited lecturer at important scientific events like: the workshop *Best Practices for Advanced Fracture Assessment* organized by European Commission – Joint Research Center, Institute for Energy, Petten, (Netherlands) 2004, at the *9th International Fracture Mechanics Summer School*, Varna (Bulgaria) 2005, at two advanced courses organized by CISM Udine (Italy) in 2009 and 2013, at the workshop *Frontiers on structural dynamics* at Beijing University of Civil Engineering and Architecture (China) 2017, symposium *7th Israelian Structural Integrity Group* at Tel Aviv University (Israel) 2018.

Prof. Marșavina is member in the Editorial board of *Fatigue and Fracture of Engineering materials and Structures* (Wiley) from 2016, *Frattura ed Integrità Strutturale* (Italian Group of Fracture) from 2014, *International Journal of Structural Integrity* (Emerald) from 2009, *Proceedings of the Romanian, Series A: Mathematics, Physics, Technical Sciences, Information Science* (Romanian Academy) from 2018. Also, he was editor of special issues for journals: *Fatigue and Fracture of Engineering materials and Structures*, Virtual Issue – *Mixed Mode Loading: Recent Developments* (2016); *Advances in Materials Science and Engineering*, Special



Issue – *Brittle or Quasi-Brittle Fracture of Engineering Materials* (2016); *Theoretical and Applied Fracture Mechanics*, Special Issue *Mixed Mode Fracture* (2017); *Materials*, Special Issue – *Advances in Metal Foams* (2018–2019). Prof. Marsavina is reviewer for more than 20 international journals.

As an international recognition prof. Marșavina is from 2014 co-chairman of the Technical Committee **TC13 – Education of European Structural Integrity Society** (ESIS) and representative of Romania in ESIS from 2006. At the 22nd European Conference on Fracture, held in Belgrade 26–31 August 2018, he was elected Vice President of *European Structural Integrity Society*.

## Romanian Academy The „Aurel Vlaicu“ Prize awarded in 2018 Remus-Daniel ENE, PhD, Vasile MARINCA, PhD & Valentin-Bogdan MARINCA, PhD

The Romanian Academy “Aurel Vlaicu” prize for Technical Sciences for 2016 was awarded to the group of papers “Optimal approximate analytical methods in the dynamic study of non-Newtonian fluids”, authors Ene Remus-Daniel, Marınca Vasile and Marınca Bogdan, affiliated to University Politehnica of Timisoara. The award ceremony took place in the high hall for science and culture at the General Assembly of the Romanian Academy on 13<sup>th</sup> December 2018.

The prize regards the papers:

- Remus-Daniel Ene, Vasile Marınca, and Valentin Bogdan Marınca, Viscous flow and heat transfer over an unsteady stretching surface, *Open Phys.*, 2016, vol. 14, pp. 371–381, DOI 10.1515/phys-2016-0042.
- Remus-Daniel Ene, Vasile Marınca, and Valentin Bogdan Marınca, Thin film flow of an Oldroyd 6-constant fluid over a moving belt: an analytic approximate solution, *Open Phys.*, 2016, vol. 14, pag. 44–64, DOI 10.1515/phys-2016-0005.
- Remus-Daniel Ene, Vasile Marınca, and Valentin Bogdan Marınca, Analytic Approximate Solutions to the Boundary Layer Flow Equation over a Stretching Wall with Partial Slip at the Boundary, *PLOS ONE*, 2016, vol. 11(3), 24 pages, DOI:10.1371/journal.pone.0149334.

These articles apply the methods of Optimal Homotopy Asymptotic Method (OHAM) and Optimal Homotopy Perturbation Method (OHPM) for finding the approximate analytical solutions for dynamical nonlinear systems from fluid mechanics. The important applications of this field describe heat and mass transfer, for example: microchip production, the linings of mammalian lungs, crystal growing, extrusion of plastic sheet, drawing plastic films, paper production, performance of lubricants, continuous casting, polymer extrusion, manufacture and drawing of plastics and rubber sheets, wire drawing and so on.

The aforementioned methods present some advantages compared to the classical one, among them we recall: there are not necessary small or large parameters in the equations or in the boundary/initial conditions, the construction is based on determination of the linear operators and of the auxiliary functions, which are combined in a convenient way to optimally control the convergence of the approximate solutions. The efficiency of the proposed procedure is proven, while an accurate solution is explicitly analytically obtained in an iterative way after one iteration only. The validity of this method is demonstrated by comparing the results obtained with the numerical solution.

Prof. dr. Vasile Marınca is member of the Center for Advanced and Fundamental Technical Research, Romanian Academy, Timișoara Branch. His field of research is Applied Mathematics in engineering.

Dr. Remus-Daniel Ene is Assistant Professor within the Department of Mathematics, UPT since 2002. He is the author of 26 ISI papers, in the field of Applied Mathematics.

Dr. Bogdan Marınca is Associate Professor within the Department of Applied Electronics, UPT. He works in the field of Applied Electronics.



## Romanian Academy The „Anghel Saligny“ Prize awarded in 2018 Prof. Florea DINU, PhD & Assist. Prof. Ioan MĂRGINEAN, PhD

“Anghel Saligny” Award of Romanian Academy to Prof. Florea DINU, PhD and Assist. Prof. Ioan Marginean, PhD for a series of five scientific papers entitled „Robustness of steel building structures”.

The list of articles awarded by Romanian Academy is based on the research carried out within the framework of the national research project PN II 55/2012 “Structural conception and collapse control performance based design of multistory structures under accidental actions” CODEC, funded by UEFISCDI and carried out during the period 2012–2016, project director Florea Dinu ([www.ct.upt.ro/centre/cemsig/codec.htm](http://www.ct.upt.ro/centre/cemsig/codec.htm)). Ioan Mărginean was member of the research team for the whole period of the project. CODEC research project supported also Mr. Ioan Mărginean in obtaining, in 2017, his PhD degree with the thesis “Behavior of beam-to-column connections subjected to high axial loads”, coordinator Acad. Dan Dubina.

The series of papers had a significant impact on the research in the field of robustness:

- 43 citations in the scientific literature, including 29 in ISI indexed journals and 14 in Scopus indexed journals;
- Preparation and submission of project proposals in national and international competitions (UEFISCDI; H2020; COST ESF; RFCS);
- Support for MSc, PhD and Habilitation theses;
- Two of the papers were included in a review of the most important contributions in the research and practice on progressive collapse and robustness of building structures in the 21st century (Adam J.M., Parisi F., Sagaseta J., Lu XZ, Research and practice on progressive collapse and robustness of building structures in the 21<sup>st</sup> century, *Engineering Structures*, 173, pp. 122–149, October 2018).



## Romanian Academy

### The „Gheorghe Ionescu-Șișești” Prize awarded in 2018

Assoc. Prof. Daniel HĂDĂRUGĂ, PhD & Assist. Prof. Gerlinde RUSU, PhD

“ROMANIAN ACADEMY AWARDS - 2016” ceremony was held on December 13, 2018, in Bucharest, during the General Meeting of the Romanian Academy. Seventy awards belonging to fourteen sections have been awarded for the top scientifically publications in the year 2016.

Two of the “Gheorghe Ionescu-Șișești” Awards, “Agricultural and Forestry Sciences” section, has been awarded for the scientifically contributions entitled “Differentiation of the rye and wheat flour as well as mixtures by using the kinetics of Karl Fischer water titration” and “Nanoencapsulation competitiveness of omega-3 fatty acids and correlations of thermal analysis and Karl Fisher water titration for European anchovy (*Engraulis encrasicolus* L) oil /  $\beta$ -cyclodextrin complexes”.

These studies were published in highly esteemed top journals Food Chemistry (Elsevier) 2016, 195, 49-55, and LWT - Food Science and Technology (Elsevier) 2016, 68, 135-144 (quartile Q1 in WoS), having authors from the Politehnica University Timișoara Assoc. Prof. Daniel Hădărugă, PhD and Assist. Prof. Gerlinde Rusu, PhD from the Department of Applied Chemistry, Organic and Natural Compounds Engineering (CAICON), Faculty of Industrial Chemistry and Environmental Engineering.

Researches were conducted in collaboration with researchers from the country and abroad (Heinz-Dieter Isengard - University of Hohenheim, Germany, Mustafa Ünlüsayın - Akdeniz University, Turkey, as well as Nicoleta Hădărugă, Corina Costescu, Laura Corpaș - University of Agricultural Sciences and Veterinary Medicine “King Mihai I of Romania” of Timișoara, Virgil Păunescu and Alexandra Gruia - University of Medicine and Pharmacy of Timișoara). They are approaching theoretical and applicative subjects in the food chemistry and supramolecular chemistry fields. Researches have a high level of multidisciplinary, dealing the influence of cereal product composition on the bonding of water molecules into the food matrix from the kinetic point of view. On the other hand, the protection and stability of omega-3 fatty acid-based triglycerides, contained by fish oils, have been evaluated by cyclodextrin nanoencapsulation. Both studies have great impact on the quality and stability of these products with food, pharmaceutical or cosmetic applications, and further to the human health.

These studies had significant impact in the scientific world, being cited in highly esteemed journals from the organic chemistry and food chemistry fields from Elsevier, Springer and Beilstein Institute (e.g., Food Chemistry - ISI 4.529, Food and Bioprocess Technology - ISI 2.998, International Journal of Thermal Sciences - ISI 3.361 and Beilstein Journal of Organic Chemistry - ISI 2.330).



- Hădărugă, D.I.; Costescu, C.I.; Corpaș, L.; Hădărugă, N.G.; Isengard, H.-D., Differentiation of rye and wheat flour as well as mixtures by using the kinetics of Karl Fischer water titration, Food Chemistry 2016, 195, 49-55, doi: 10.1016/j.foodchem.2015.08.124 (ISI 4.529 / Q1);
- Ünlüsayın, M.; Hădărugă, N.G.; Rusu, G.; Gruia, A.T.; Păunescu, V.; Hădărugă, D.I., Nano-encapsulation competitiveness of omega-3 fatty acids and correlations of thermal analysis and Karl Fischer water titration for European anchovy (*Engraulis encrasicolus* L.) oil /  $\beta$ -cyclodextrin complexes, LWT – Food Science and Technology 2016, 68, 135-144, doi: 10.1016/j.lwt.2015.12.017 (ISI 2.329 / Q1).



## Romanian Academy & the Romanian National Committee of the World Energy Council „Mircea Dimitrie Cazacu” awards for the best doctoral thesis - Second prize Mihail Reinhold WÄCHTER , PhD

The 14<sup>th</sup> WEC CENTRAL & EASTERN EUROPE REGIONAL ENERGY FORUM - FOREN 2018 with the main theme: „Central and Eastern Europe in the New Era of Energy Transition: Challenges, Investment Opportunity and Technological Innovations” will be held in Vox Maris Grand Resort, Costinesti, Romania, during 10-14 June 2018.

The event is organized by the WEC Romanian National Committee, under the auspices of the Government of Romania, under the leadership of the World Energy Council (WEC) and with the support of WEC Member Committees in Central and Eastern Europe.

### Award of the Romanian Academy for a UPT graduate

A graduate of Politehnica University Timișoara has received an important award from the Romanian Academy and the Romanian National Committee of the World Energy Council for the results of his research on waste recovery.

Thus, following the analysis of the national applications for the “Mircea Dimitrie Cazacu” awards for the best doctoral thesis in the field of renewable energy sources, the Romanian Academy, through the Renewable Energy Commission of the Technical Sciences Section, and the Romanian National Committee of the World Energy Council decided to award the second prize to Dr. Mihail Reinhold Wächter for the thesis “Theoretical and Experimental Research on Methods of Energy Recovery from Municipal Solid Wastes”, elaborated under coordination of Prof. Ioana Ionel, PhD, and validated with the excellent score, namely Summa cum laude. Note that the first place was not awarded.

At European level, considerable efforts have been made over the last decades to find the most efficient and sustainable solutions for the management of household waste and, implicitly, waste resulting from its incineration in an environmentally friendly way with minimal impact on the environment.

Mr. Mihail Reinhold Wächter is a graduate of the Thermal Machines and Equipment specialization and of the Master of Energy and Thermal Engineering and Transport Vehicles of the Faculty of Mechanical Engineering of Politehnica University Timișoara, currently having a 10 year professional experience in design (ISPE Timișoara) and process engineering (SC COLTERM SA Timișoara) and thus a great ability to put into practice the engineering knowledge acquired during his career. He is also active in the UPT, being a director of a nationally-funded project, also in the field of environmentally friendly environmental protection research: “Innovative method for landfilling of municipal solid Waste Incineration Residues by STABilization/solidification into coal fly ash rock matrix resulted from dense slurry technology”, acronym: WIR-STAB-01, Project code: PN-III-P1-1.1-PD-2016-1093, Contract no.93 / 2018.



## European Federation for Medical Informatics (EFMI) EFMI President for the term 2018 - 2020 Prof. Lăcrămioara STOICU-TIVADAR, PhD

In April 2018, during the MIE 2018 conference meeting in Gothenburg, Sweden, the EFMI Council elected the EFMI President for the term 2018-2020 as Lăcrămioara Stoicu-Tivadar, Professor at the Faculty of Automation and Computers from Politehnica University Timișoara.

The European Federation for Medical Informatics (EFMI) is the leading non-profit organization in biomedical and health informatics in Europe. The Federation comprises 30 national societies and includes an exceptional network of experts and stakeholders in healthcare, IT and its societal dimensions; to this national member we add 14 topic Working Groups ranging from human factors, to security and natural language processing and 10 Institutional members contributing to the industrial view of the association. The national members are Full Members. The main bodies of EFMI are the Council and the Executive Board. The Council gathers one representative from each Full Member, the Members of the Executive Board, the Chairpersons of the Working Groups, the Honorary Fellows and two representatives of the Institutional Members. The Council (only the Full members) elects an Executive Board consisting of President, Vice-President, Past President, Secretary, Treasurer, and several Officers.

In April 2018, during the MIE 2018 conference meeting in Gothenburg, Sweden, the EFMI Council elected - with 21 votes and 1 blanc - the EFMI President for the term 2018-2020 as Lăcrămioara Stoicu-Tivadar, Professor at the Faculty of Automation and Computers from Politehnica University Timișoara. Prof. Stoicu-Tivadar is the second president elected directly by Council vote and the first woman that took the new challenge and succeeded. The ceremony of investing the new EFMI President took place on October 16, 2018, at the International Conference MIE-STC 2018 held in Zagreb, Croatia.

The 3 directions on which Prof. Lăcrămioara Stoicu-Tivadar is working to develop the EFMI community are a closer cooperation with the medical professional associations (a project with EUSEM – European Society for Emergency Medicine was initiated immediately after taking the term), emphasizing the importance of young scientists in EFMI – creating a new position in the EFMI Board supporting this direction, and continuing the EFMI participation in European projects. Prof. Stoicu-Tivadar participates constantly in MIE and STC EFMI organized conferences, with papers, keynotes and as chair/member of Science Program Committees. She is President of the Romanian Society of Medical informatics and Senior IEEE member.



Prof. Lăcrămioara Stoicu-Tivadar was involved in national (MedINS/ MediNET, TELEASIS, SIMIMED) and international projects (CASA, Trillium Bridge), industry supported projects and presentations (IBM Award 2007, keynote in Milano during IBM Academic Days 2014) and has an intense and consistent research and educational activity related to digital healthcare. She initiated (2009) and coordinates the activity of the Healthcare Information System master's degree at the Faculty of Automation and Computers.

European recognition of the value of the Politehnica University Timișoara professors is always a reason for pride confirming the quality and innovative work promoted in UPT.



## European Structural Integrity Society (ESIS) ESIS Vice President Prof. Liviu MARȘAVINA, PhD

At the 22<sup>nd</sup> European Conference on Fracture, held in Belgrade, Serbia between 26 – 31 August 2018 was elected the new Vice President Prof. Liviu Marșavina from Politehnica University Timișoara (Romania).

European Structural Integrity Society (ESIS) is a non-profit organisation run by the Executive Committee that is instructed by and responsible to a Council of delegates representing each European Country affiliated to the Society, as well as the Technical Committee chair – persons. ESIS has 17 Technical Committees and 25 affiliated countries (including Romania).

Structural Integrity refers to the safe operation of engineering components, structures and materials, and addresses the science and technology used to assess the margin between safe operation and failure.

The aim of ESIS is to develop and extend knowledge in all aspects of Structural Integrity and disseminating that knowledge world wide with the objective of improving the safety and performance of engineering equipment, individual components and structures.

Specifically:

- to foster research and collaboration into the prevention of failure of engineering materials, components and structures under mechanical loadings and associated phenomena.
- to encourage interdisciplinary research into the physical behaviour of engineering components, materials and structures.
- to develop new testing methods, numerical methods, and engineering estimation methods for structural integrity assessment.
- to improve engineering designs.
- to improve manufacturing, inspection and maintenance procedures.
- to develop methods for interpretation of material property data, probabilistic assessment and tools for failure prevention and management.
- to disseminate knowledge, by means of scientific publications, procedure documents, and referring developments to national and international code-making bodies where relevant.
- to educate young engineers and scientists in structural integrity matters.

ESIS is associated with Elsevier for publishing four well-recognized journals: *Engineering Fracture Mechanics*, *International Journal of Fatigue*, *Theoretical and Applied Fracture Mechanics* and *Engineering Failure Analysis*, as well for publishing the *Procedia Structural Integrity* with contributions from organized meetings.

Executive Committee headed by President and two Vice Presidents assures the management of ESIS. The Council represented by the President, who acts as Chairman of Council, the two Vice Presidents, two delegates, one of whom is a voting member, from each of the National Groups of affiliated European countries, the Chairperson of each Technical Committee and the Secretary, who acts as Secretary to the Council elects them.

At the 22<sup>nd</sup> European Conference on Fracture, held in Belgrade, Serbia between 26 – 31 August 2018 the new President Prof. Francesco Iacoviello from Università di Cassino e del Lazio Meridionale (Italy) and Vice Presidents Prof. Alexander Sedmak from University of Belgrade (Serbia) and Prof. Liviu Marșavina from Politehnica University Timișoara (Romania) were elected for a four year mandate.

Prof. Liviu Marșavina had an important contribution in the affiliation of Romanian Association of Fracture Mechanics (ARMR) to ESIS. Since 2006 he participated at all European Conferences on Fracture organized by ESIS in Alexandropolis (Greece) in 2006, Brno (Czech Republic ) in 2008, Dresden (Germany) 2010, Kazan (Russia) 2012, Trondheim (Norway) 2014, Catania (Italy) 2016 and Belgrad (Serbia) in 2018. From 2014 Prof. Marșavina acted as Co - Chair of the ESIS Technical Committee TC13: Education and Training.



## International Exhibition of Inventions of Geneva 2018 Diploma & Silver Medal Ștefan PAVEL, PhD

The event *International Exhibition of Inventions of Geneva* took place in Switzerland, in the period of 11-15 april, 2018, where the following invention was presented: PORTABLE DEVICE FOR PAIN SIGNALING, OR DISCOMFORT DURING THE DENTAL PROCEDURES.

The awards won at this event are as follows:

- Diploma of the *International Exhibition of Inventions of Geneva*, with a silver medal;
- The international innovation award of the Polish Academy of Sciences, *Institute of Genetics and Animal Breeding from Poland* with diploma and medal.

The author of the invention presented at this event carry out their professional activity in Politehnica University Timișoara, at *Research Institute for Renewable Energy*.

The invention relates to a portable electrical device for signaling pain, sensitivity or discomfort during a dental medical act.

The advantages of this invention are as follows:

- The device is easily maneuverable and attached to the dental chair;
- Optionally providing a luminous, acoustic and (or) voice signaling of a patient's pain or discomfort during dental procedures;
- Provides safety in operation by using low-voltage currents and simplicity of electrical controls;;
- Ensures an almost instantaneous alert when the patient is in pain or discomfort.



## 18<sup>th</sup> IEEE International Conference on Advanced Learning Technologies - ICALT2018 Best Paper Award

Diana ANDONE, PhD, Silviu VERT, PhD, Mark FRYDENBERG, PhD & Radu VASIU, PhD

The team consisting of Diana Andone, Silviu Vert, Mark Frydenberg and Radu Vasiu has been awarded with “Best Paper Award” for the paper “Open Virtual Reality Project to Improve Students’ Skills” presented at the 18<sup>th</sup> IEEE International Conference on Advanced Learning Technologies ICALT2018, which took place in Mumbai, India in July 9-13, 2018. (<http://www.ieee-icalt.org>)

ICALT is an annual international conference on *Advanced Learning Technologies* and *Technology-enhanced Learning* organized by the IEEE Computer Society and the IEEE Technical Committee on Learning Technology. After its kick-off as IWALT in Palmerston North, New Zealand (2000), ICALT has been held in Madison, USA (2001), Kazan, Russia (2002), Athens, Greece (2003), Joensuu, Finland (2004), Kaohsiung, Taiwan (2005), Kerkade, The Netherlands (2006), Niigata, Japan (2007), Santander, Spain (2008), Riga, Latvia (2009), Sousse, Tunisia (2010), Athens, Georgia, USA (2011), Rome, Italy (2012), Beijing, China (2013), Athens, Greece (2014), Hualien, Taiwan (2015), Austin, Texas, USA (2016) and Timisoara, Romania (2017).

The 18<sup>th</sup> IEEE International Conference on Advanced Learning Technologies (ICALT2018) was organized at the Indian Institute of Technology Bombay (IIT Bombay), Mumbai, India.

There were fourteen tracks in ICALT 2018:

- Track 1. Technologies for Open Learning and Education (i-OPENLearn), **Diana Andone**, Politehnica University Timișoara, [Co-ordinator]
- Track 2. Adaptive and Personalized Technology-Enhanced Learning (APTel)
- Track 3. Wireless, Mobile, Pervasive and Ubiquitous Technologies for Learning (WMUTE)
- Track 4. Digital Game and Intelligent Toy Enhanced Learning (DIGITEL)
- Track 5. Computer Supported Collaborative Learning (CSCL)
- Track 6. Big Data in Education and Learning Analytics (BDELA)
- Track 7. Technology-Enhanced Science, Technology, Engineering and Math Education (TeSTEM)
- Track 8. Technology Enhanced Language Learning (TELL)
- Track 9. Technology Enabled Learning of Thinking Skills (TELoTS)
- Track 10. Technology Supported Education for People with Disabilities (TeDISABLE)
- Track 11. Artificial Intelligence and Smart Learning Environments (AISLE)
- Track 12. Augmented Reality and Virtual Worlds in Education and Training (ARWET)
- Track 13. Motivational and Affective Aspects in Technology-enhanced Learning (MA-TEL)
- Track 14. Applications of Semantic Web technologies for Learning (SW-EL)

The anticipated types of submissions for all tracks were:

- Full paper: 5 pages
- Short paper: 3 pages
- Posters: 2 pages

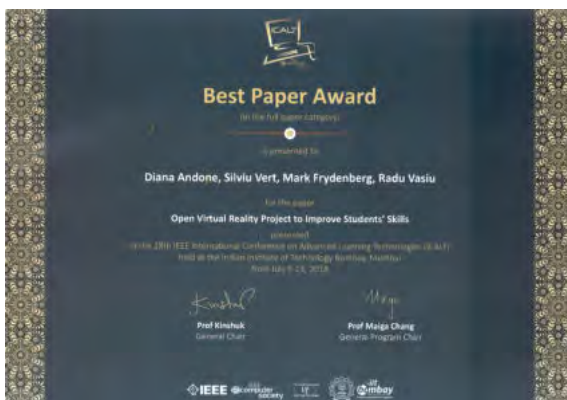

## 1<sup>st</sup> International Conference on Computational Methods and Applications in Engineering Best Paper Award Silviu VERT, PhD & Diana ANDONE, PhD

The team consisting of Silviu Vert and Diana Andone has been awarded with “Best Paper Award” for the paper “Virtual Reality Authoring Tools for Educators” presented at the 1<sup>st</sup> International Conference on Computational Methods and Applications in Engineering which took place in Timișoara, Romania in May 23 - 26, 2018. (<http://iccmæe.elearning.upt.ro/>)

The objectives of this conference are to enhance interdisciplinary international work between scientists and engineers in USA and Romania. In addition to plenary lectures, there will be sessions for mini-symposia and contributed talks.

The main topics are:

### Track 1: Applied/Computational Mathematics

- Fractional Calculus
- Image Processing
- Mathematical Biology
- Optimal Control
- Differential Equations and their Numerical Methods

### Track 2: Computational Methods in Mechanical Engineering

- Applied mathematics and Mechanics
- Applied Thermodynamics
- Applied Analytical and Numerical Material Modelling
- Computational Fluid Dynamics

### Track 3: Applications in Information Technologies

- Open Data Applications
- Applied Statistics and Big Data Analytics
- Smart Cities Applications
- Integrated Infrastructures and Processes for Smart Cities
- eScience and the Information Society
- Virtual and Augmented Reality



## MakeLearn & TIIM 2018 International Scientific Conference

### Best Paper Award

Matei TĂMĂȘILĂ, PhD, Ilie TĂUCEAN, PhD, Alin ARTENE, PhD & Claudiu ALBULESCU, PhD

The paper entitled “Financial performance in the public administration sector: comparison between Romania and Hungary” (authors Matei Tămășilă, Ilie Tăucean, Alin Artene and Claudiu Albulescu) received the distinction of “Best Paper Award”, delivered by Scientific Committee of the MakeLearn & TIIM 2018 International Scientific Conference “Integrated Economy and Society: Diversity, Creativity and Technology”, held in Naples (Italy), on 16 to 18 May 2018.

The purpose of the MakeLearn & TIIM 2018 International Conference was to share most recent developments in the fields of management, economics, technology, and education.

The work was supported by a grant of the Romanian National Authority for Scientific Research and Innovation, CNCS-UEFISCDI, project number, PN-II-RU-TE-2014-4-1760, project entitled “The impact of the economic and financial stability on investments, innovation process and entrepreneurial activity in the EU” (Director, Prof. Claudiu ALBULESCU). The paper was published in 2018 in “Management”.



## International Exhibition IDEA-Expo 2018 Abony Trophy, Cup, Medals & Diplomas Ștefan PAVEL, PhD

The event "International Exhibition IDEA-Expo 2018 Abony" took place in Hungary, in the period of 24-25 march, 2018.

The prizes won at this event are the following:

- *Second place, with the trophy received from the Parliament of Hungary (represented by the member of the parliament, Volner János)*; Volner János országgyűlési képviselő díjai-Bujdosó Tibor (H) Abony; Dr. Stefan Pavel (RO) Temesvár; Hegedűs Fanni (H) Abony;Különdíj: ABOKOM Kft. (H) Abony;
- *IDEA Cup and Diploma awarded to Politehnica University Timișoara;*
- *"IDEA butella Abony" Award;*
- *8 Medals with diplomas awarded by the Hungarian Inventors Association, president Nagy Zoltán, Ötlet Club 13 Egyesület elnöke, Hódmezővásárhely;*
- *Diploma for Politehnica University Timișoara, awarded by the BALKAN MANAGERS ASSOCIATION;*
- *Diploma awarded by the Inventors Association from Bačka Palanka - the Serbian Republic for the prototypes in the dental medical field.*

The authors of the inventions presented at this event carry out their professional activity in Politehnica University Timișoara, "Victor Babes" University of Medicine and Pharmacy Timișoara", and private societies.

The inventions presented, as they appear from the titles presented below, are intended for the dental medical field and make a considerable contribution to the modernization and proper development of the professional activity of the medical staff.



These are the following:

- *INSTALLATION FOR THE DECONTAMINATION OF THE RESIDUAL WATER FROM THE DENTAL UNIT, RO 129343A8, autors:Pavel Ștefan, Borza Ioan, Bratu Emanuel Adrian, DoboșiloanSilviu, Găină Paulina Ioana, Streian Felicia, Talpoș Niculescu Șerban;*
- *LIGHTING INSTALLATION FOR THE „CERAMIC CHAMBER” COMPARTMENT OF DENTAL TECHNOLOGY, RO 2013 00033, autors: Pavel Ștefan, Borza Ioan, Bratu Emanuel Adrian, Doboșiloan Silviu, Găină Paulina Ioana, Streian Felicia, Talpoș Niculescu Șerban;*
- *COMPRESSED AIR INSTALLATION FOR DENTAL UNITS, RO 2013 00050, autors:Pavel Ștefan, Borzaloan;*
- *ELECTRICAL INSTALLATION FOR THE AIR DISINFECTION DESIGNED FOR DENTAL MEDICAL UNITS, RO 2014 00031, autors: Pavel Ștefan, Tutelcă Ancașa Letiția, Jifcu Deian Adrian, Lăcătușu Eugen-Florin, Adam Andrei, Vlad Daliborca Cristina, Dumitrașcu Victor, Hogeia Elena, Borza Iconia Ecaterina, Suciuc Silviu Cristian;*
- *PORTABLE DEVICE FOR AIR AND SURFACE DISINFECTION FROM CLOSED SPACES U/00045/16.07.2015, autors: Pavel Ștefan, Suciuc Silviu-Cristian*
- *PORTABLE DEVICE FOR PAIN SIGNALING, OR DISCOMFORT DURING THE DENTAL PROCEDURES, RO 2015 00055, autors: Pavel Ștefan;*
- *MOBILE INSTALLATION FOR THE SUPPORT OF THE CHILD DURING PEDIATRIC RADIOLOGY, U/00021/08.06.2016, autors: Pavel Ștefan, Popoiu Călin Marius, Mocan Marian Liviu, Doboșiloan Silviu, Șerban Dan-Andrei;*
- *ELECTRICAL LIGHTING INSTALLATION FOR DENTAL ESTHETICS, U/00018 28.04.2017 , autors: Pavel Ștefan, Kremcs Cristina, Mocan Marian Liviu, DoboșiloanSilviu.*





## „Orizonturi Universitare” Association, Romanian Academy Timișoara Branch & Timișoara’s Local Council „Eminent Young Researcher” Award Assist. Prof. Mircea-Bogdan RĂDAC, PhD

On December 11<sup>th</sup> 2018, Assistant Professor Mircea-Bogdan Rădac, PhD from the Department of Automation and Applied Informatics of Politehnica University Timișoara, received the “Eminent Young Researcher” award from the “Orizonturi Universitare” Association, in partnership with Romanian Academy Timișoara Branch, and with the Timișoara’s Local Council.

The XXIII edition of the yearly „Eminent Student” event awards the best students and young researchers from across all city universities and took place in the „Alexandru Rogojan” amphitheatre of the Politehnica University Timișoara.

The award acknowledged Dr. Rădac’s fruitful research activity of the last ten years on the areas of Control and Systems Engineering, Artificial Intelligence and Electrical and Electronic Engineering, encompassing publication of more than 140 scientific articles in journals and conference proceedings and participation with his team members in management and research activities for research grants won by national competitions.



## Orthodox Metropolis of Banat & Timis County Council 2018 „Pro Cultura Timisiensis” for a member of the Politehnica academic community Assoc. Prof. Mariana CERNICOVA-BUCĂ, PhD

In 2001 the Timiș County Council decided to award the prize “Pro Cultura Timisiensis” to artists, writers, researchers who contribute decisively to the growth of the cultural thesaurus of Banat region. Starting with 2017, the Pro Cultura Timisiensis Gala is organized by the county public authority in cooperation with the Orthodox Metropolis of Banat.

Among the 24 personalities celebrated in December 2018 one belongs to the academic community of Politehnica University Timișoara: assoc. prof. Mariana Cernicova-Bucă from the Faculty of Communication Sciences, UPT, nominated for the prize on the initiative of the Association University Horizons (Orizonturi Universitare). In the Laudatio for assoc. prof. Mariana Cernicova-Bucă it is stated that the nominee published as a single author or in co-authorship 19 books, 9 of which are dedicated to the history and culture of Timis county and Timisoara city. Out of these, the volume dedicated to the history of the region (*Din cronologia județului Timiș*) was published in 4 editions,

in enriched and revised versions. Mrs. Mariana Cernicova-Bucă is also actively engaged in the life of the country and the region and received diplomas and awards to recognize her work in publishing, research activities and public service. She chairs the Board of Communication and Public Relations at the Faculty of Communication Sciences in Politehnica University Timișoara, coordinates the communication programs at the Master level at her faculty, co-edits the *Professional Communication and Translation Studies* (PCTS) volumes and acts as chair of the scientific committee for the PCTS conference since 2013.



## Politehnica University Timișoara Award for EXCELLENCE IN RESEARCH Assoc. Prof. Călin Adrian POPA, PhD

At the end of the year, Politehnica University Timișoara awarded the “Excellence in Research” prizes to young people who achieved remarkable results during the academic year 2017–2018.

Călin-Adrian Popa is an Associate Professor at the Department of Computers and Information Technology from the Faculty of Automation and Computers. His research activity is mainly focused on the field of machine learning in general, and neural networks in particular. In the years 2017–2018, he published, as the only author (with one exception), 3 papers in ISI journals in the Q1 quartile, and 1 paper in an ISI journal in the Q2 quartile, 2 of them at the famous journal *Neural Networks*, which has an impact factor of 7,19. Also, in the same period, he published, as the only author (with one exception), 14 papers at ISI conferences, 5 of them at the famous International Joint Conference on Neural Networks (IJCNN), the most

important and prestigious conference in the field of neural networks. He was the director of the project PCD-TC-2017-41, granted in the internal competition „Proiecte de Cercetare, Dezvoltare pentru Tineri Cercetători (PCD-TC)” (Projects of Research, Development for Young Researchers), organized by the Politehnica University Timișoara. Starting with the same period, as a recognition of his research activity, he was appointed reviewer for 9 ISI journals in the Q1 quartile and for 3 ISI journals in the Q2 quartile, including the famous journal *IEEE Transactions on Neural Networks and Learning Systems*, which has an impact factor of 7,98.





## EXECUTIVE UNIT FOR FINANCING HIGHER EDUCATION, RESEARCH, DEVELOPMENT AND INNOVATION - UEFISCDI AWARDS - ARTICLES

Through these awards UEFISCDI aims to increase quality, impact and international visibility of Romanian research by recognizing and rewarding significant results published in prestigious journals from international senior scientific stream.

Within this competition can participate the researchers affiliated to institutions in Romania, authors of scientific articles published in journals indexed by Clarivate Analytics Science Citation Index Expanded ("Science"), Social Sciences Citation Index ("Social Sciences") or Arts & Humanities Citation Index ("Arts & Humanities").

More information at <http://uefiscdi.gov.ro/Public/cat/471/Premierea-rezultatelor-cercetarii.html>

1. Baloi, M.A., Crucean, C. Fermion production by a dependent of time electric field in de Sitter universe, INTERNATIONAL JOURNAL OF MODERN PHYSICS A, Volume: 32, Issue: 36, Special Issue: SI, Article Number: 1750208, ISSN: 0217-751X, eISSN: 1793-656X, 2017;
2. Fagadar-Cosma, E., Badea, V., Fagadar-Cosma, G., Palade, A., Lascu, A., Fringu, I., Birdeanu, M. Trace Oxygen Sensitive Material Based on Two Porphyrin Derivatives in a Heterodimeric Complex, MOLECULES, Volume: 22, Issue: 10, Article Number: 1787, ISSN: 1420-3049, 2017;
3. Gabor, A., Davidescu, C.M., Negrea, A., Ciopec, M., Grozav, I., Negrea, P., Duteanu, N. Optimizing the lanthanum adsorption process onto chemically modified biomaterials using factorial and response surface design, JOURNAL OF ENVIRONMENTAL MANAGEMENT, Volume: 204, Special Issue: SI, Pages: 839-844, PubMed ID: 28148453, ISSN: 0301-4797, eISSN: 1095-8630, 2017;
4. Herban, I.S., Vilceanu, C.B., Grecea, C. Road-Structure Monitoring with Modern Geodetic Technologies, JOURNAL OF SURVEYING ENGINEERING, Volume: 143, Issue: 4, Article Number: 05017004, ISSN: 0733-9453, eISSN: 1943-5428, 2017;
5. Iliă, R., Liatsou, I., Savva, I., Vasile, E., Vekas, L., Marinica, O., Mpekris, F., Pashalidis, I., Krasia-Christoforou, T. Magnetoresponse polymer networks as adsorbents for the removal of U (VI) ions from aqueous media, EUROPEAN POLYMER JOURNAL, Volume: 97, Pages: 138-146, ISSN: 0014-3057, eISSN: 1873-1945, 2017;
6. Linul, E., Marsavina, L., Kovacic, J., Sadowski, T. DYNAMIC AND QUASI-STATIC COMPRESSION TESTS OF CLOSED-CELL ALUMINIUM ALLOY FOAMS, PROCEEDINGS OF THE ROMANIAN ACADEMY SERIES A-MATHEMATICS PHYSICS TECHNICAL SCIENCES INFORMATION SCIENCE, Volume: 18, Issue: 4, Pages: 361-369, ISSN: 1454-9069, 2017;
7. Marinca, B., Marinca, V. NEW EXACT AND EXPLICIT SOLUTIONS OF THE ZAKHAROV EQUATIONS AND GENERALIZED ZAKHAROV EQUATIONS BY THE QUOTIENT TRIGONOMETRIC FUNCTION EXPANSION METHOD, PROCEEDINGS OF THE ROMANIAN ACADEMY SERIES A-MATHEMATICS PHYSICS TECHNICAL SCIENCES INFORMATION SCIENCE, Volume: 18, Issue: 2, Pages: 166-173, ISSN: 1454-9069, 2017;
8. Mnerie, C., Preitl, S., Duma, V.F. Galvanometer-Based Scanners: Mathematical Model and Alternative Control Structures for Improved Dynamics and Immunity to Disturbances, INTERNATIONAL JOURNAL OF STRUCTURAL STABILITY AND DYNAMICS, Volume: 17, Issue: 5, Special Issue: SI, Article Number: 1740006, ISSN: 0219-4554, eISSN: 1793-6764, 2017;
9. Moisa, M.E., Spelmezan, C.G., Paul, C., Bartha-Vari, J.H., Bencz, L.C., Irimie, F.D., Paizs, C., Peter, F., Tosa, M.I. Tailored sol-gel immobilized lipase preparates for the enzymatic kinetic resolution of heteroaromatic alcohols in batch and continuous flow systems, RSC ADVANCES, Volume: 7, Issue: 83, Pages: 52977-52987, ISSN: 2046-2069, 2017;
10. Mosoarca, M., Keller, A.I., Petrus, C., Racolta, A. Failure analysis of historical buildings due to climate change, ENGINEERING FAILURE ANALYSIS, Volume: 82, Pages: 666-680, ISSN: 1350-6307, eISSN: 1873-1961, 2017;
11. Paulescu, M., Pop, N., Stefu, N., Paulescu, E., Boata, R., Calinoiu, D. SEASONAL MODELING OF HOURLY SOLAR IRRADIATION SERIES, ROMANIAN JOURNAL OF PHYSICS, Volume: 62, Issue: 7-8, Article Number: 813, ISSN: 1221-146X, 2017;
12. Popov, D. ON SOME PROPERTIES OF THE K-COHERENT STATES, PROCEEDINGS OF THE ROMANIAN ACADEMY SERIES A-MATHEMATICS PHYSICS TECHNICAL SCIENCES INFORMATION SCIENCE, Volume: 18, Issue: 4, Pages: 323-330, ISSN: 1454-9069, 2017;
13. Racuciu, M., Iftode, C., Miclaus, S. ULTRAHIGH FREQUENCY-LOW POWER ELECTROMAGNETIC FIELD IMPACT ON PHYSIOLOGICAL PARAMETERS OF TWO TYPES OF CEREALS, ROMANIAN REPORTS IN PHYSICS, Volume: 69, Issue: 4, Article Number: 712, ISSN: 1221-1451, eISSN: 1841-8759, 2017;

No.

UEFISCDI Awards

14. Aliha, M.R.M., Linul, E., Bahmani, A., Marsavina, L. Experimental and theoretical fracture toughness investigation of PUR foams under mixed mode I plus III loading, *POLYMER TESTING*, Volume: 67, Pages: 75-83, ISSN: 0142-9418, eISSN: 1873-2348, 2018;
15. Ancuti, C.O., Ancuti, C., De Vleeschouwer, C., Bekaert, P. Color Balance and Fusion for Underwater Image Enhancement, *IEEE TRANSACTIONS ON IMAGE PROCESSING*, Volume: 27, Issue: 1, Pages: 379-393, PubMed ID: 28981416, ISSN: 1057-7149, eISSN: 1941-0042, 2018;
16. Baloi, M.A., Crucean, C., Popescu, D. Scalar pair production in a magnetic field in de Sitter universe, *EUROPEAN PHYSICAL JOURNAL C*, Volume: 78, Issue: 5, Article Number: 398, ISSN: 1434-6044, eISSN: 1434-6052, 2018;
17. Belega, D., Petri, D., Dallet, D. Accurate amplitude and phase estimation of noisy sine-waves via two-point interpolated DTFT algorithms, *MEASUREMENT*, Volume: 127, Pages: 89-97, ISSN: 0263-2241, eISSN: 1873-412X, 2018;
18. Belega, D., Petri, D., Dallet, D. Accurate frequency estimation of a noisy sine-wave by means of an interpolated discrete-time Fourier transform algorithm, *MEASUREMENT*, Volume: 116, Pages: 685-691, ISSN: 0263-2241, eISSN: 1873-412X, 2018;
19. Belega, D., Petri, D., Dallet, D. INFLUENCE OF THE SPECTRAL IMAGE COMPONENT ON THE AMPLITUDE AND PHASE ESTIMATORS PROVIDED BY THE INTERPOLATED DFT METHOD, *PROCEEDINGS OF THE ROMANIAN ACADEMY SERIES A-MATHEMATICS PHYSICS TECHNICAL SCIENCES INFORMATION SCIENCE*, Volume: 19, Issue: 2, Pages: 377-384, ISSN: 1454-9069, 2018;
20. Berei, E., Stefanescu, O., Muntean, C., Vlase, T., Taranu, B.O., Dabici, A., Stefanescu, M. A novel route for the preparation of CoCr204/SiO2 nanocomposite starting from Co(II)-Cr(III) carboxylate complex combinations, *JOURNAL OF MATERIALS SCIENCE*, Volume: 53, Issue: 6, Pages: 4159-4172, ISSN: 0022-2461, eISSN: 1573-4803, 2018;
21. Binzar, T., Lazureanu, C. Wold-Type Decompositions for a Commutative Pair of Noncommutative Semigroups of Isometries, *BULLETIN OF THE MALAYSIAN MATHEMATICAL SCIENCES SOCIETY*, Volume: 41, Issue: 2, Pages: 1139-1150, ISSN: 0126-6705, eISSN: 2180-4206, 2018;
22. Boldea, I., Tutelea, L.N., Xu, W., Pucci, M. Linear Electric Machines, Drives, and MAGLEVs: An Overview, *IEEE TRANSACTIONS ON INDUSTRIAL ELECTRONICS*, Volume: 65, Issue: 9, Pages: 7504-7515, ISSN: 0278-0046, eISSN: 1557-9948, 2018;
23. Calinoiu, D., Stefu, N., Boata, R., Blaga, R., Pop, N., Paulescu, E., Sabadus, A., Paulescu, M. Parametric modeling: A simple and versatile route to solar irradiance, *ENERGY CONVERSION AND MANAGEMENT*, Volume: 164, Pages: 175-187, ISSN: 0196-8904, eISSN: 1879-2227, 2018;
24. Chesoi, A., Stratan, A., Dubina, D. Design implementation of re-centring dual eccentrically braced frames with removable links, *SOIL DYNAMICS AND EARTHQUAKE ENGINEERING*, Volume: 112, Pages: 174-184, ISSN: 0267-7261, eISSN: 1879-341X, 2018;
25. Cocheci, L., Lupa, L., Gheju, M., Golban, A., Lazau, R., Pode, R. Zn-Al-CO3 layered double hydroxides prepared from a waste of hot-dip galvanizing process, *CLEAN TECHNOLOGIES AND ENVIRONMENTAL POLICY*, Volume: 20, Issue: 5, Pages: 1105-1112, ISSN: 1618-954X, eISSN: 1618-9558, 2018;
26. Craciunescu, C., Mitelea, I. Combined effects in quasisimilar NiTi joints manufactured by pulsed laser welding, *MATERIALS SCIENCE AND ENGINEERING A-STRUCTURAL MATERIALS PROPERTIES MICROSTRUCTURE AND PROCESSING*, Volume: 737, Pages: 364-372, ISSN: 0921-5093, eISSN: 1873-4936, 2018;
27. Curiac, D.I., Baniac, O., Volosencu, C., Curiac, C.D. Novel Bioinspired Approach Based on Chaotic Dynamics for Robot Patrolling Missions with Adversaries, *ENTROPY*, Volume: 20, Issue: 5, Article Number: UNSP 378, ISSN: 1099-4300, 2018;
28. Declercq, D., Savin, V., Boncalo, O., Ghaffari, F. An Imprecise Stopping Criterion Based on In-Between Layers Partial Syndromes, *IEEE COMMUNICATIONS LETTERS*, Volume: 22, Issue: 1, Pages: 13-16, ISSN: 1089-7798, eISSN: 1558-2558, 2018;
29. Dumitru, R., Manea, F., Pacurariu, C., Lupa, L., Pop, A., Cioabla, A., Surdu, A., Ianculescu, A. Synthesis, Characterization of Nanosized ZnCr2O4 and Its Photocatalytic Performance in the Degradation of Humic Acid from Drinking Water, *CATALYSTS*, Volume: 8, Issue: 5, Article Number: 210, ISSN: 2073-4344, 2018;
30. Gheju, M. Progress in Understanding the Mechanism of Cr-VI Removal in Fe-O-Based Filtration Systems, *WATER*, Volume: 10, Issue: 5, Article Number: 651, ISSN: 2073-4441, Published: 2018;

No.

UEFISCDI Awards

31. Gherhes, V., Obrad, C. Technical and Humanities Students' Perspectives on the Development and Sustainability of Artificial Intelligence (AI), SUSTAINABILITY, Volume: 10, Issue: 9, Article Number: 3066, ISSN: 2071-1050, 2018;
32. Gontean, A., Lica, S., Bularka, S., Szabo, R., Lascu, D. A Novel High Accuracy PV Cell Model Including Self Heating and Parameter Variation, ENERGIES, Volume: 11, Issue: 1, Article Number: 36, ISSN: 1996-1073, 2018;
33. Grecu, E., Aceleanu, M.I., Albulescu, C.T. The economic, social and environmental impact of shale gas exploitation in Romania: A cost-benefit analysis, RENEWABLE & SUSTAINABLE ENERGY REVIEWS, Volume: 93, Pages: 691-700, ISSN: 1364-0321, Published: 2018;
34. Grigorie, A.C., Muntean, C., Vlase, G., Stefanescu, M. Synthesis and characterization of ZnAl<sub>2</sub>O<sub>4</sub> spinel from Zn(II) and Al(III) carboxylates, JOURNAL OF THERMAL ANALYSIS AND CALORIMETRY, Volume: 131, Issue: 1, Pages: 183-189, ISSN: 1388-6150, eISSN: 1588-2926, 2018;
35. Groza, B., Murvay, P.S. SECURITY SOLUTIONS FOR THE CONTROLLER AREA NETWORK Bringing Authentication to In-Vehicle Networks, IEEE VEHICULAR TECHNOLOGY MAGAZINE, Volume: 13, Issue: 1, Pages: 40-47, ISSN: 1556-6072, eISSN: 1556-6080, 2018;
36. Gurbina, M., Ciresan, A., Lascu, D., Lica, S., Pop-Calimanu, I.M. A New Exact Mathematical Approach for Studying Bifurcation in DCM Operated dc-dc Switching Converters, ENERGIES, Volume: 11, Issue: 3, Article Number: 663, ISSN: 1996-1073, 2018;
37. Ianos, R. Key-role of the recipe formulation in the solution combustion synthesis of monocalcium aluminate, CaAl<sub>2</sub>O<sub>4</sub>, CERAMICS INTERNATIONAL, Volume: 44, Issue: 17, Pages: 21908-21913, ISSN: 0272-8842, eISSN: 1873-3956, 2018;
38. Ianos, R., Lazau, R., Babuta, R., Muntean, E., Moaca, E.A., Pacurariu, C. Solution combustion synthesis: a straightforward route for the preparation of chromium-doped lanthanum aluminate, LaAl<sub>1-x</sub>Cr<sub>x</sub>O<sub>3</sub>, pink red pigments, DYES AND PIGMENTS, Volume: 155, Pages: 218-224, ISSN: 0143-7208, eISSN: 1873-3743, 2018;
39. Ianos, R., Moaca, E.A., Caprarua, A., Lazau, R., Pacurariu, C. Maghemite, gamma-Fe<sub>2</sub>O<sub>3</sub>, nanoparticles preparation via carbon-templated solution combustion synthesis, CERAMICS INTERNATIONAL, Volume: 44, Issue: 12, Pages: 14090-14094, ISSN: 0272-8842, eISSN: 1873-3956, 2018;
40. Ianos, R., Muntean, E., Lazau, R., Babuta, R., Moaca, E.A., Pacurariu, C., Dabici, A., Hulka, I. One-step synthesis of near-infrared reflective brown pigments based on iron-doped lanthanum aluminate, LaAl<sub>1-x</sub>Fe<sub>x</sub>O<sub>3</sub>, DYES AND PIGMENTS, Volume: 152, Pages: 105-111, ISSN: 0143-7208, eISSN: 1873-3743, 2018;
41. Ianos, R., Pacurariu, C., Muntean, S.G., Muntean, E., Nistor, M.A., Niznansky, D. Combustion synthesis of iron oxide/carbon nanocomposites, efficient adsorbents for anionic and cationic dyes removal from wastewaters, JOURNAL OF ALLOYS AND COMPOUNDS, Volume: 741, Pages: 1235-1246, ISSN: 0925-8388, eISSN: 1873-4669, 2018;
42. Khoa L., Declercq, D., Ghaffari, F., Kessal, L., Boncalo, O., Savin, V. Variable-Node-Shift Based Architecture for Probabilistic Gradient Descent Bit Flipping on QC-LDPC Codes, IEEE TRANSACTIONS ON CIRCUITS AND SYSTEMS I-REGULAR PAPERS, Volume: 65, Issue: 7, Pages: 2183-2195, ISSN: 1549-8328, eISSN: 1558-0806, 2018;
43. Kovacic, J., Marsavina, L., Linul, E. Poisson's Ratio of Closed-Cell Aluminium Foams, MATERIALS, Volume: 11, Issue: 10, Article Number: 1904, PubMed ID: 30301257, ISSN: 1996-1944, 2018;
44. Lazureanu, C. Integrable Deformations of Three-Dimensional Chaotic Systems, INTERNATIONAL JOURNAL OF BIFURCATION AND CHAOS, Volume: 28, Issue: 5, Article Number: 1850066, ISSN: 0218-1274, eISSN: 1793-6551, 2018;
45. Li, X., Xu, W., Ye, C.Y., Boldea, I. Comparative Study of Transversal-Flux Permanent-Magnetic Linear Oscillatory Machines for Compressor, IEEE TRANSACTIONS ON INDUSTRIAL ELECTRONICS, Volume: 65, Issue: 9, Pages: 7437-7446, ISSN: 0278-0046, eISSN: 1557-9948, 2018;
46. Linul, E., Movahedi, N., Marsavina, L. On the Lateral Compressive Behavior of Empty and Ex-Situ Aluminum Foam-Filled Tubes at High Temperature, MATERIALS, Volume: 11, Issue: 4, Article Number: 554, PubMed ID: 29617300, ISSN: 1996-1944, 2018;
47. Linul, E., Movahedi, N., Marsavina, L. The temperature and anisotropy effect on compressive behavior of cylindrical closed-cell aluminum-alloy foams, JOURNAL OF ALLOYS AND COMPOUNDS, Volume: 740, Pages: 1172-1179, ISSN: 0925-8388, eISSN: 1873-4669, 2018;

No.

UEFISCDI Awards

48. Linul, E., Serban, D.A., Marsavina, L. Influence of Cell Topology on Mode I Fracture Toughness of Cellular Structures, *PHYSICAL MESOMECHANICS*, Volume: 21, Issue: 2 Pages: 178-186, ISSN: 1029-9599, eISSN: 1990-5424, 2018;
49. Lupa, L., Cocheci, L., Pode, R., Hulka, I. Phenol adsorption using Aliquat 336 functionalized Zn-Al layered double hydroxide, *SEPARATION AND PURIFICATION TECHNOLOGY*, Volume: 196, Special Issue: SI, Pages: 82-95, ISSN: 1383-5866, eISSN: 1873-3794, 2018;
50. Maranescu, B., Lupa, L., Visa, A. Heavy metal removal from waste waters by phosphonate metal organic frameworks, *PURE AND APPLIED CHEMISTRY*, Volume: 90, Issue: 1, Pages: 35-47, ISSN: 0033-4545, eISSN: 1365-3075, 2018;
51. Marc, S., Kirovski, D., Mircu, C., Hutu, I., Otava, G., Paul, C., Boldura, O.M., Tulcan, C. Serum Protein Electrophoretic Pattern in Neonatal Calves Treated with Clinoptilolite, *MOLECULES*, Volume: 23, Issue: 6, Article Number: 1278, PubMed ID: 29861463, ISSN: 1420-3049, 2018;
52. Marinca, B., Marinca, V. APPROXIMATE ANALYTICAL SOLUTIONS FOR THIN FILM FLOW OF A FOURTH GRADE FLUID DOWN A VERTICAL CYLINDER, *PROCEEDINGS OF THE ROMANIAN ACADEMY SERIES A-MATHEMATICS PHYSICS TECHNICAL SCIENCES INFORMATION SCIENCE*, Volume: 19, Issue: 1, Pages: 69-76, ISSN: 1454-9069, 2018;
53. Marinca, B., Marinca, V. Some exact solutions for MHD flow and heat transfer to modified second grade fluid with variable thermal conductivity in the presence of thermal radiation and heat generation/absorption, *COMPUTERS & MATHEMATICS WITH APPLICATIONS*, Volume: 76, Issue: 6, Pages: 1515-1524, ISSN: 0898-1221, eISSN: 1873-7668, 2018;
54. Mitelea, I., Ghera, C., Bordeasu, I., Craciunescu, C. Assessment of Cavitation Erosion of Gas-Nitrided Cr-Ni-Mo Steels, *JOURNAL OF TRIBOLOGY-TRANSACTIONS OF THE ASME*, Volume: 140, Issue: 6, Article Number: 061601, ISSN: 0742-4787, eISSN: 1528-8897, 2018;
55. Moisa, M.E., Poppe, L., Gal, C.A., Bencze, L.C., Irimie, F.D., Paizs, C., Peter, F., Tosa, M.I. Click reaction- aided enzymatic kinetic resolution of secondary alcohols, *REACTION CHEMISTRY & ENGINEERING*, Volume: 3, Issue: 5, Pages: 790-798, ISSN: 2058-9883, 2018;
56. Mosoarca, M., Keller, A.I. A complex assessment methodology and procedure for historic roof structures, *INTERNATIONAL JOURNAL OF ARCHITECTURAL HERITAGE*, Volume: 12, Issue: 4, Special Issue: SI, Pages: 578-598, ISSN: 1558-3058, eISSN: 1558-3066, 2018;
57. Movahedi, N., Linul, E. Mechanical properties of Light Expanded Clay Aggregated (LECA) filled tubes, *MATERIALS LETTERS*, Volume: 217, Pages: 194-197, ISSN: 0167-577X, eISSN: 1873-4979, 2018;
58. Murvay, P.S., Groza, B. Security Shortcomings and Countermeasures for the SAE J1939 Commercial Vehicle Bus Protocol, *IEEE TRANSACTIONS ON VEHICULAR TECHNOLOGY*, Volume: 67, Issue: 5, Pages: 4325-4339, ISSN: 0018-9545, eISSN: 1939-9359, 2018;
59. Negrea, A., Gabor, A., Davidescu, C.M., Ciopec, M., Negrea, P., Duteanu, N., Barbulescu, A. Rare Earth Elements Removal from Water Using Natural Polymers, *SCIENTIFIC REPORTS*, Volume: 8, Article Number: 316, PubMed ID: 29321487, ISSN: 2045-2322, 2018;
60. Negru, R., Serban, D.A., Pop, C., Marsavina, L. Notch effect assessment in a PUR material using a ring shaped specimen, *THEORETICAL AND APPLIED FRACTURE MECHANICS*, Volume: 97, Pages: 500-506, ISSN: 0167-8442, eISSN: 1872-7638, 2018;
61. Nelson, J.D.B., Gibberd, A.J., Nafornita, C., Kingsbury, N. The locally stationary dual-tree complex wavelet model, *STATISTICS AND COMPUTING*, Volume: 28, Issue: 6, Pages: 1139-1154, ISSN: 0960-3174, eISSN: 1573-1375, 2018;
62. Niyonzima, S., Pop, N., Iacob, F., Larson, A., Orel, A.E., Mezei, J.Z., Chakrabarti, K., Laporta, V., Hassouni, K., Benredjem, D., Bultel, A., Tennyson, J., Reiter, D., Schneider, I.F. Low-energy collisions between electrons and BeD<sup>+</sup>, *PLASMA SOURCES SCIENCE & TECHNOLOGY*, Volume: 27, Issue: 2, Article Number: 025015, ISSN: 0963-0252, eISSN: 1361-6595, 2018;
63. Obrad, C., Gherhes, V. A Human Resources Perspective on Responsible Corporate Behavior. Case Study: The Multinational Companies in Western Romania, *SUSTAINABILITY*, Volume: 10, Issue: 3, Article Number: 726, ISSN: 2071-1050, 2018;
64. Pana, A., Baloi, A., Molnar-Matei, F. From the Balancing Reactive Compensator to the Balancing Capacitive Compensator, *ENERGIES*, Volume: 11, Issue: 8, Article Number: 1979, ISSN: 1996-1073, 2018;
65. Pop, C., Ene, R.D. Stability problems and numerical integration on the Lie group  $SO(3) \times R-3 \times R-3$ , *OPEN MATHEMATICS*, Volume: 16, Pages: 219-234, ISSN: 2391-5455, 2018;



No.

UEFISCDI Awards

66. Popa, C.A. Global exponential stability of neutral-type octonion-valued neural networks with time-varying delays, *NEUROCOMPUTING*, Volume: 309, Pages: 117-133, ISSN: 0925-2312, eISSN: 1872-8286, 2018;
67. Popa, C.A. Global exponential stability of octonion-valued neural networks with leakage delay and mixed delays, *NEURAL NETWORKS*, Volume: 105, Pages: 277-293, PubMed ID: 29890384, ISSN: 0893-6080, eISSN: 1879-2782, 2018;
68. Popa, C.A. Learning Algorithms for Quaternion-Valued Neural Networks, *NEURAL PROCESSING LETTERS*, Volume: 47, Issue: 3, Special Issue: SI, Pages: 949-973, ISSN: 1370-4621, eISSN: 1573-773X, 2018;
69. Popa, C.A., Kaslik, E. Multistability and multiperiodicity in impulsive hybrid quaternion-valued neural networks with mixed delays, *NEURAL NETWORKS*, Volume: 99, Pages: 1-18, PubMed ID: 29306800, ISSN: 0893-6080, eISSN: 1879-2782, 2018;
70. Popov, D. THERMAL STATES IN THE k-GENERALIZED HYPERGEOMETRIC COHERENT STATES REPRESENTATION, *PROCEEDINGS OF THE ROMANIAN ACADEMY SERIES A-MATHEMATICS PHYSICS TECHNICAL SCIENCES INFORMATION SCIENCE*, Volume: 19, Issue: 3, Pages: 431-438, ISSN: 1454-9069, 2018;
71. Radac, M.B., Precup, R.E. Data-driven model-free slip control of anti-lock braking systems using reinforcement Q-learning, *NEUROCOMPUTING*, Volume: 275, Pages: 317-329, ISSN: 0925-2312, eISSN: 1872-8286, 2018;
72. Radac, M.B., Precup, R.E., Roman, R.C. Data-driven model reference control of MIMO vertical tank systems with model-free VRFT and Q-Learning, *ISA TRANSACTIONS*, Volume: 73, Pages: 227-238, PubMed ID: 29325777, ISSN: 0019-0578, eISSN: 1879-2022, 2018;
73. Radu, D., Sedmak, A., Bancila, R. Determining the crack acceptability in the welded joints of a wind loaded cylindrical steel shell structure, *ENGINEERING FAILURE ANALYSIS*, Volume: 91, Pages: 341-353, ISSN: 1350-6307, eISSN: 1873-1961, 2018;
74. Reisz, E., von Sonntag, C., Tekle-Rottering, A., Naumov, S., Schmidt, W., Schmidt, T.C. Reaction of 2-propanol with ozone in aqueous media, *WATER RESEARCH*, Volume: 128, Pages: 171-182, PubMed ID: 29102696, ISSN: 0043-1354, 2018;
75. Roman, M., Roman, D.L., Ostafe, V., Ciorsac, A., Isvoran, A. Computational Assessment of Pharmacokinetics and Biological Effects of Some Anabolic and Androgen Steroids, *PHARMACEUTICAL RESEARCH*, Volume: 35, Issue: 2, Article Number: UNSP 41, PubMed ID: 29404794, ISSN: 0724-8741, eISSN: 1573-904X, 2018;
76. Sarbu, I., Dorca, A. A comprehensive review of solar thermoelectric cooling systems, *INTERNATIONAL JOURNAL OF ENERGY RESEARCH*, Volume: 42, Issue: 2, Pages: 395-415, ISSN: 0363-907X, eISSN: 1099-114X, Published: 2018;
77. Sarbu, I., Sebarchievici, C. A Comprehensive Review of Thermal Energy Storage, *SUSTAINABILITY*, Volume: 10, Issue: 1, Article Number: 191, ISSN: 2071-1050, Published: 2018;
78. Stanciu, E.M., Pascu, A., Roata, I.C., Croitoru, C., Tieren, M., Rosca, J.M., Hulka, I. Solar radiation synthesis of functional carbonaceous materials using Al<sub>2</sub>O<sub>3</sub>/TiO<sub>2</sub>-Cu-HA doped catalyst, *APPLIED SURFACE SCIENCE*, Volume: 438, Pages: 33-40, ISSN: 0169-4332, eISSN: 1873-5584, 2018;
79. Taherishargh, M., Linul, E., Broxtermann, S., Fiedler, T. The mechanical properties of expanded perlite-aluminium syntactic foam at elevated temperatures, *JOURNAL OF ALLOYS AND COMPOUNDS*, Volume: 737, Pages: 590-596, ISSN: 0925-8388, eISSN: 1873-4669, 2018;
80. Tigan, G., Analysis of Degenerate Fold-Hopf Bifurcation in a Three-Dimensional Differential System, *QUALITATIVE THEORY OF DYNAMICAL SYSTEMS*, Volume: 17, Issue: 2, Pages: 387-402, ISSN: 1575-5460, eISSN: 1662-3592, 2018;
81. Todea, A., Borza, P., Cimporescu, A., Paul, C., Peter, F. Continuous kinetic resolution of aliphatic and aromatic secondary alcohols by sol-gel entrapped lipases in packed bed bioreactors, *CATALYSIS TODAY*, Volume: 306, Pages: 223-232, ISSN: 0920-5861, eISSN: 1873-4308, 2018;
82. Topirceanu, A., Udrescu, M., Marculescu, R. Weighted Betweenness Preferential Attachment: A New Mechanism Explaining Social Network Formation and Evolution, *SCIENTIFIC REPORTS*, Volume: 8, Article Number: 10871, PubMed ID: 30022079, ISSN: 2045-2322, 2018;

No.

UEFISCDI Awards

83. Truong, N.L.T., Savin, V., Le, K., Declercq, D., Ghaffari, F., Boncalo, O. Analysis and Design of Cost-Effective, High-Throughput LDPC Decoders, IEEE TRANSACTIONS ON VERY LARGE SCALE INTEGRATION (VLSI) SYSTEMS, Volume: 26, Issue: 3, Pages: 508-521, ISSN: 1063-8210, eISSN: 1557-9999, 2018;
84. Ursu, D., Miclau, N., Miclau, M. n-Type Conductivity of Cu<sub>2</sub>O Thin Film Prepared in Basic Aqueous Solution Under Hydrothermal Conditions, ELECTRONIC MATERIALS LETTERS, Volume: 14, Issue: 4, Pages: 405-412, ISSN: 1738-8090, eISSN: 2093-6788, 2018;
85. Vlascici, D., Plesu, N., Fagadar-Cosma, G., Lascu, A., Petric, M., Crisan, M., Belean, A., Fagadar-Cosma, E. Potentiometric Sensors for Iodide and Bromide Based on Pt(II)-Porphyrin, SENSORS, Volume: 18, Issue: 7, Article Number: 2297, PubMed ID: 30012951, ISSN: 1424-8220, 2018;
86. Vlazan, P., Stoia, M. Structural and magnetic properties of CoFe<sub>2</sub>O<sub>4</sub> nanopowders, prepared using a modified Pechini method, CERAMICS INTERNATIONAL, Volume: 44, Issue: 1, Pages: 530-536, ISSN: 0272-8842, eISSN: 1873-3956, 2018.

## EXECUTIVE UNIT FOR FINANCING HIGHER EDUCATION, RESEARCH, DEVELOPMENT AND INNOVATION - UEFISCDI AWARDS - GRANTED PATENTS

1. Iclanzan T.A. Municipal waste collection plant, OSIM, RO 129774 B1, 30.07.2018.





# PROJECTS SUPPORTED BY PUBLIC FUNDS



# National Research Projects





## PROJECTS SUPPORTED BY NATIONAL PUBLIC FUNDS IMPLEMENTED BY UPT 2018

Fields	Total number of projects	Number of projects presented
Social and Economic sciences	2	1
Bioeconomy	1	1
Biology and Ecology	1	-
Eco-Nano-Tehnologies and advanced materials	3	3
Energy, environment and climatic changes	12	12
Mathematics and Informatics	5	3
Health	1	-
Materials science	2	1
Earth Sciences	1	-
Engineering science	29	5
Information and Communication Technology, Space and Security	9	9
<b>Total</b>	<b>66</b>	<b>35</b>



## EVOLUTION OF PROJECTS SUPPORTED BY NATIONAL PUBLIC FUNDS IMPLEMENTED BY UPT 2014 - 2018

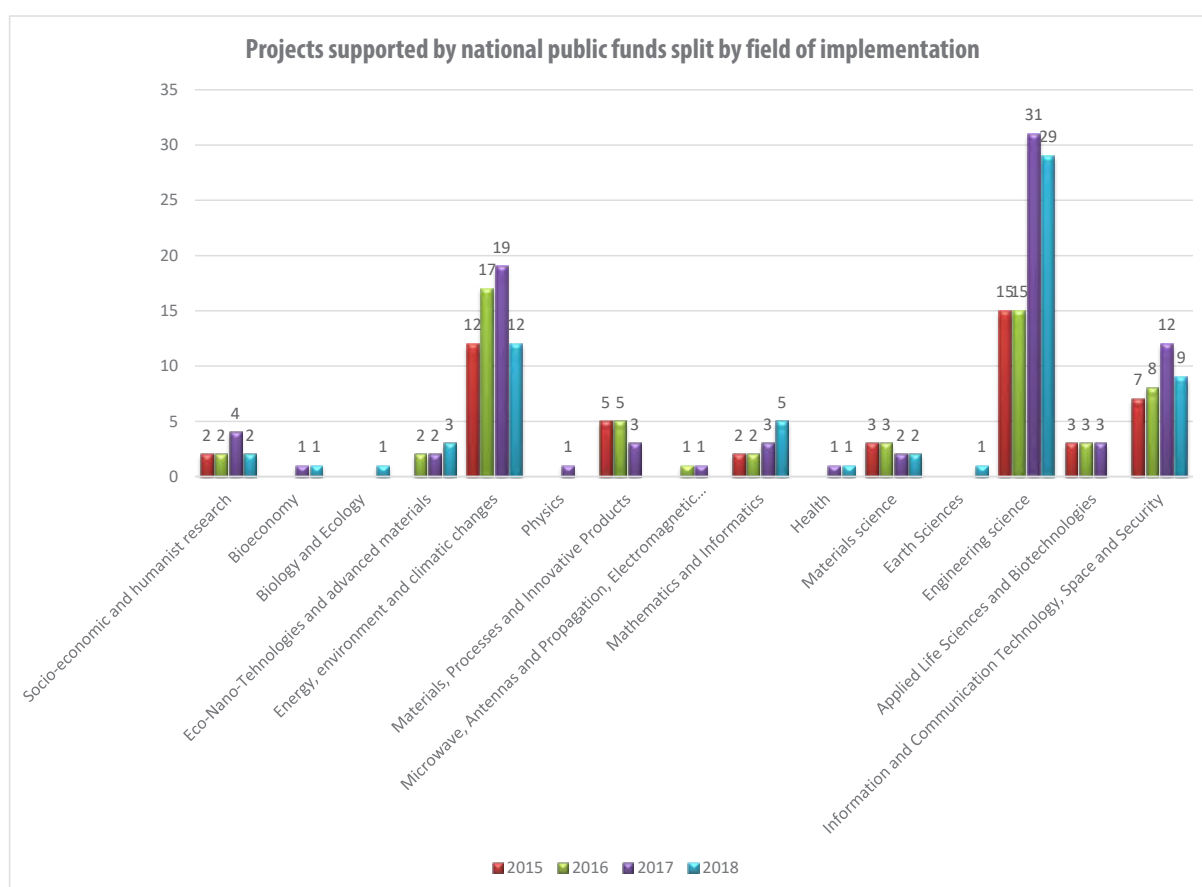
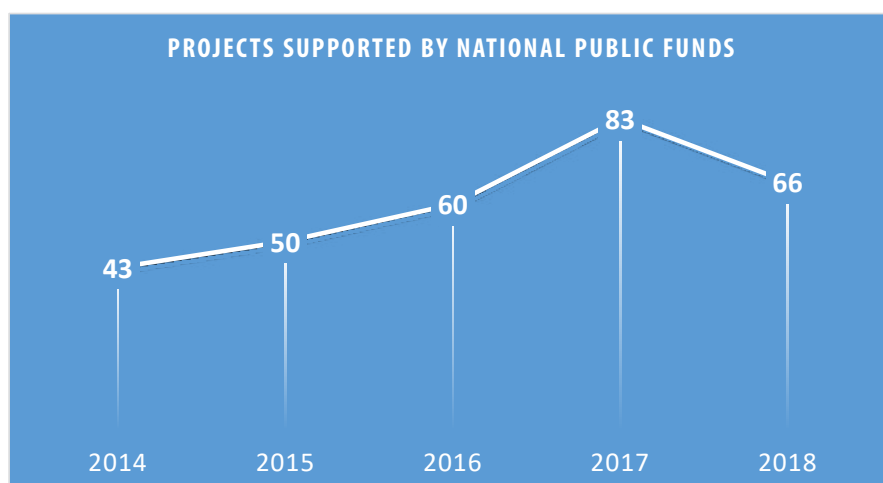



## PRESENCE - PRIVACY-ENABLED, SECURED INTERACTIONS BETWEEN VEHICLES AND SMART ELECTRONIC DEVICES

### Goal of the project:

The main target of the project is the design, analysis and implementation of security and privacy mechanisms for mediating access to in-vehicle functionalities by using intelligent mobile devices instead of classical RF and/or mechanical vehicle keys that are rigid and are lacking in terms of configurability and functionalities. The design of such security solutions is challenged by limitations on computational capabilities of existing components, e.g., in-vehicle controllers, as well as by the potential insecurity of smartphones.

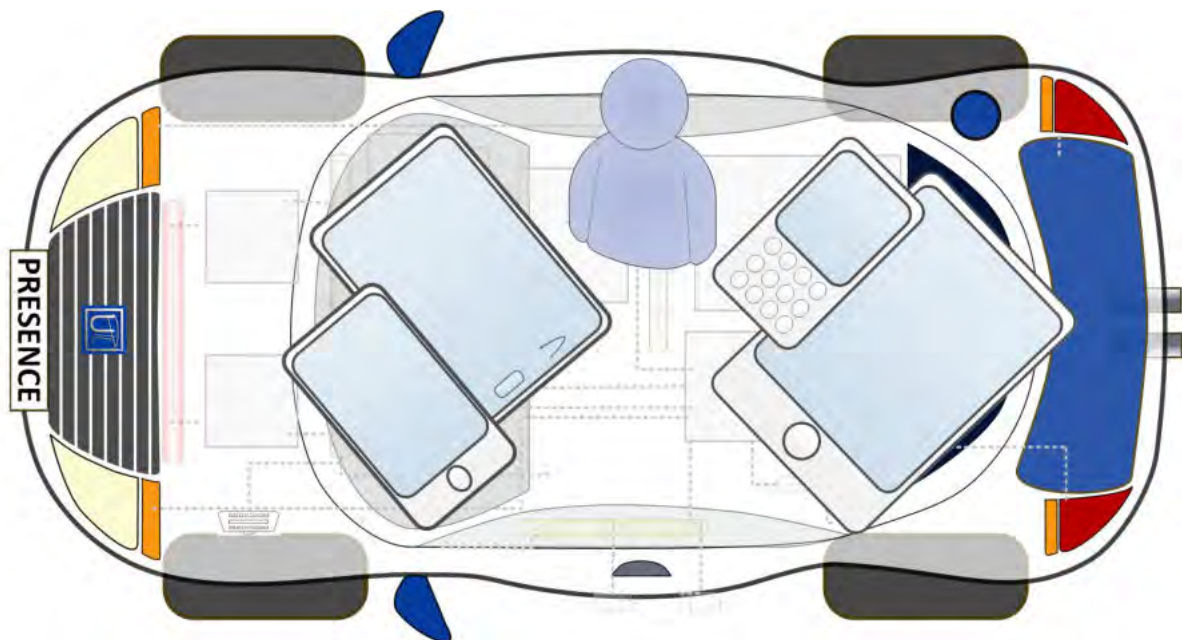

### Short description of the project:

PRESENCE addresses the security of the newly emerged ecosystem of modern vehicles that interact with intelligent mobile devices, e.g., smart-phones.

### Project implemented by

Politehnica University Timișoara

### Implementation period:

2018-2020

### Main activities:

Our project calls for the use of security enforcing technologies (e.g., NFC security cards) and modern device pairing techniques by harvesting environmental data (e.g., accelerometer data) to provide a secure and usable solution. Privacy enhancing technologies also need to be put in place in order to protect the users in front of corrupted cloud owners. As deployment platform we target Android, the mobile OS with the largest installed base. We also test the computational feasibility of the proposed solutions on a commonly employed controller for car BCMs. Main project objectives:

1. Design, analysis and implementation of security protocols.
2. Security enforcing technologies (e.g., NFC cards).
3. Ecosystem-based device association (e.g., accelerometer data).
4. Cloud-based access control.
5. Connectivity to in-vehicle control units.

## Results:

We expect 5-10 research papers in relevant workshops and journals in the field addressing new concepts in vehicle access control supported by practical deployments on real-world components. PRESENCE is still in its first year of run, the publication list will be updated on the project website.

[1] Tudor Andreica, Bogdan Groza, Stefan Murvay, Applications of Pairing-Based Cryptography on Automotive-Grade Microcontrollers, 1st International Workshop on Safety, security, and pRivacy In automotiVe systEms (STRIVE 2018, SAFECOMP 2018 Workshops), Vasteras, Sweeden.

[2] Camil Jichici, Bogdan Groza, Stefan Murvay, Examining the Use of Neural Networks for Intrusion Detection in Controller Area Networks, 11th International Conference on Innovative Security Solutions for Information Technology and Communications, SecITC 2018, Bucharest, Romania, 2018

## Applicability and transferability of the results:

Replacing traditional keys with smartphones appears like a natural step for achieving increased usability and an improved user experience. Industry application of the designed protocols and implemented functionalities for car access control by modern smartphones is immediate.

## Financed through/by

CNCS-UEFISCDI PN-III-P1-1.1-TE-2016-1317, 2018-2020

## Research Centre

Department of Automation and Applied Informatics

## Research team

Prof. Bogdan GROZA, PhD  
Assoc. Prof. Stefan MURVAY, PhD  
Assist. Horatiu GURBAN, PhD  
Eng. Tudor-Sebastian ANDREICA  
Eng. Camil JICHICI

## Contact information

Prof. Bogdan GROZA, PhD  
Faculty of Automatics and Computers  
Department of Automation and Applied Informatics  
Address: Bd. V. Parvan nr. 2, Timisoara  
Phone: (+40) 256 403 242  
E-mail: bogdan.groza@aut.upt.ro  
Web: <http://www.aut.upt.ro/~bgroza/projects/presence/index.html>

## SECURITY ENHANCEMENTS AND VULNERABILITY ASSESSMENT FOR INDUSTRY-STANDARD NETWORKS (SEVEN)

### Goal of the project

Since most attacks on industry-standard networks rely on vulnerabilities the SEVEN project aims to assess vulnerabilities in protocols not yet analyzed. For adding security to industrial networks we propose mechanisms to assure basic security objectives (e.g. authenticity, confidentiality or key management). The project will also investigate and design intrusion detection systems. Finally, we also consider a performance impact evaluation of the introduction of the designed security solutions.

### Short description of the project

Vulnerability evaluation and development of protection mechanisms for in industry-standard networks.

### Project implemented by

PaI-Ștefan MURVAY (Project leader)  
Bogdan GROZA (Mentor)

### Implementation period

02/05/2018-30/04/2020

### Main activities

The project is structured around three main activities.

The first main activity focuses on vulnerability assessment of industry-standard communication protocols. Our goal is to identify industry-standard communication-protocols that were not analyzed from a security perspective and identify potential vulnerabilities.

Our first approach for enhancing the security of industry-standard communication protocols is the development of mechanisms for assuring basic security objectives such as: authenticity, confidentiality or key management.

A second approach focuses on designing intrusion detection mechanisms for the early identification of attack attempts.

Finally, we intend to provide an evaluation of the performance impact of the proposed mechanisms.

### Results

The results obtained in the first phase of the SEVEN project have been published as part of two conference papers. Both focus on the first main project activity, i.e., vulnerability assessment of industry-standard communication protocols.

Our first result covers the identification of vulnerabilities in the FlexRay communication protocol. We identified a set of denial of service attacks that can affect the entire communication or just targeted frames. We also found that FlexRay frames sent in the dynamic segment can be falsified.

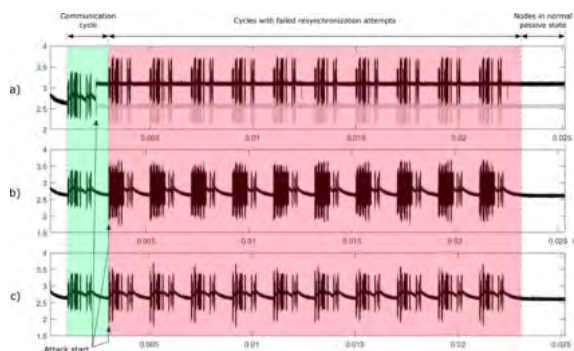

Figure 1. Three variants of the DoS attack for the entire communication.

A second line of research focused on the DeviceNet protocol. We found that DeviceNet is vulnerable to a set of denial of service attacks that can prevent a node from achieving communication on the network while not affecting the communication between other nodes.

## Applicability and transferability of the results

Our results add to the already known vulnerabilities of communication protocols used in industrial applications.

Without proper mitigation mechanisms these attacks can be used by malicious parties to disrupt communication of safety critical systems in an automotive environment (in the case of FlexRay) or in an industrial control system (in the case of DeviceNet).

Knowledge of the vulnerabilities is an important building block of designing proper security mechanisms for these communication protocols.

## Financed through/by

This work was supported by a grant of the Romanian Ministry of Research and Innovation, CNCS - UEFISCDI, project number PN-III-P1-1.1-PD-2016-1198, within PNCDI III

## Contact information

Assoc. Prof. Pal-Ştefan MURVAY, PhD  
Faculty of Automatics and Computers  
Department of Automation and Applied Informatics  
Address: Str. Vasile Pârvan, No. 2, Postal Code 300223, Timisoara  
Phone: (+40) 256 403 242  
E-mail: stefan.murvay@upt.ro  
Web: <http://www.aut.upt.ro/~pal-stefan.murvay/>



## NONLINEAR OBSERVERS-BASED CONTROL STRUCTURES APPLIED TO MECHATRONICS SYSTEMS

### Goal of the project

The main objective of this project is to develop the necessary tools, modern control solutions and theoretical framework for later multi-purpose applications related to mechatronics systems.

The following objectives are defined:

01. Analysis, design and implementation of modern control solutions.
02. The validation of the proposed modeling and control approaches using simulations and experiments.
03. The dissemination of results.
04. Solving the project management issues.

### Short description of the project

It is focused on the analysis, synthesis, modeling and development of modern control solutions.

### Project implemented by

The construction of nonlinear observers still provides an open research field, efforts being made to broaden and adapt the proposed techniques in order to widen the classes of nonlinear systems to which they may apply.

### Implementation period

10/10/2018 - 09/10/2020

### Main activities

The main activities are as follows:

1. The elaboration of the synthesis on the operation and modelling of the proposed approaches.
2. The development and verification through simulation and experiments of the proposed control solutions for several classes of processes including those in mechatronics applications and laboratory control systems.
3. The development of Matlab / Simulink programs to test the proposed nonlinear observers.
4. The elaboration of comparative analyses to prove the validity of the approaches.

The potential impact to the scientific field may be significant because through new concepts and employed approaches, a new way for the use of highly advanced control designs in mechatronics applications is open.

### Results

The targeted deliverables of this project are: 1 journal paper (e.g. IEEE Transactions on Industrial Informatics, IEE Transactions on Control Systems Technology, IET Control Theory & Applications, International Journal of General Systems, International Journal of Computers, Communications & Control, Acta Polytechnica Hungarica) and 3 conference papers published in the volumes of visible international conferences.

It is possible that more publications in this area of research will follow after the project has ended but it is very risky, due to the fact that the whole cycle of research - validation - writing manuscript - submission - revisions - acceptance lasts for at least 2 years for high quality publications.

### Applicability and transferability of the results

The potential impact of the project in the scientific, social, economic or cultural environment is straightforward since the investigated topics can lead to automated tools for controller design and tuning. Although there is a wide range of possibilities for creating new themes for state-of-the-art research, noteworthy is also the impact in the socio-economic environment with directly applicative directions. In the project all mechatronics applications are focused on those applicable cost-effective training systems in the fields of robotics, automation and process control.

## Financed through/by

The state budget / UEFISCDI

## Research Centre

Politehnica University Timișoara (UPT)  
Department of Automation and Applied Informatics

## Research team

Assist. Prof. Alexandra-Iulia SZEDLAK-STÎNEAN, PhD  
Prof. Radu-Emil PRECUP, PhD

## Contact information

Assist. Prof. Alexandra-Iulia SZEDLAK-STÎNEAN, PhD  
Faculty of Automatics and Computers  
Department of Automation and Applied Informatics  
Address: Bvd. Vasile Pârvan, Nr. 2, 300223, Timisoara  
Phone: (+40) 256 403340  
Mobile: 0040-735857668  
E-mail: alexandra.szedlak-stinean@upt.ro  
alexandra-iulia.stinean@aut.upt.ro  
Web: <https://szedlak-stinean.wixsite.com/nobsmeccs>

## INTERNET OF THINGS MEETS COMPLEX NETWORKS FOR EARLY PREDICTION AND MANAGEMENT OF CHRONIC OBSTRUCTIVE PULMONARY DISEASE

### Goal of the project

To address the problem of COPD (Chronic Obstructive Pulmonary Disease) management in a big population of individuals, using a personalized medicine approach that relies on big data gathering and modeling, according to the complex network paradigm. Our scope is to demonstrate a solution that consists of a mobile and cloud computing integrated system for COPD early detection, monitoring, and management.

### Short description of the project

COPD is defined as the irreversible clinical condition which reduces pulmonary capacity; if diagnosed in an early phase, its evolution can be controlled. Unfortunately, the early detection of COPD is a difficult task. Capitalizing on recent research results which indicate the Internet of Things solutions as useful in monitoring and managing respiratory disorders, we propose a prototype system for early detection and evolution prediction of COPD. As such, we build a sensor network that gathers multiple physiological signals, and a mobile application that extracts the multi-fractal spectra as signal signatures. Then, the mobile system integrates the physiologic signatures with individual clinical data. On the server side, we collect the integrated data from a population of individuals, to build a complex network model of patients. To this end, we employ modularity clustering and network layout tools to build prediction models for both early detection and evolution prediction of COPD. The prediction model is instantiated as a smartphone application and tested to assess its predictive capacity.

### Project implemented by

The research group lead by Mihai Udrescu and affiliated to Advanced Computing Systems and Architectures Lab, Politehnica University Timișoara, and the Pulmonology Research Group from "Victor Babeș" University of Medicine and Pharmacy lead by Ștefan Mihăicuță.

### Implementation period

3.01.2017 – 30.06.2018

### Main activities

Designing and implementing the mobile software that records anthropometric and clinical data, building a prototype sensor network for collecting physiological signals, implementing the software for multifractal analysis of gathered physiological signals, finding correlations between parameters and data using a complex network model, implementing a software COPD-stage predictor based on the physiological signals.

### Results

1. Methodology for processing medical data based on complex network analysis, which allows for identification of clinically-relevant patient phenotypes. The proposed methodology is published in: Mihaicuta, S., Udrescu, M., Topirceanu, A., & Udrescu, L. (2017). Network science meets respiratory medicine for OSAS phenotyping and severity prediction. *PeerJ*, 5, e3289.
2. Experimental hardware/software platform for gathering and integrating anthropometric, clinical data with physiological signals from COPD patients.





## Applicability and transferability of the results

Active diagnosis and monitoring systems using a wearable sensor network with application in monitoring respiratory disorders.

## Financed through/by

CNCS/CCCDI-UEFISCDI, project number PN-III-P2-2.1-PED-2016-1145, within PNCDI III, contract no. 31PED/2017

## Research centre

Research Center in Computing and Information Technology (CCCTI)

## Research team

Mihai UDRESCU,  
Andrei LIHU,  
Alexandru TOPIRCEANU,  
Alexandru IOVANOVICI,  
Constantina-Elena GAVRILIU,  
Stefan MIHAICUTA,  
Daniela REISZ,  
Rodica DAN,  
Carmen ARDELEAN.

## Contact information

Assoc. Prof. Mihai UDRESCU, PhD  
Faculty of Automatics and Computers  
Department of Computer and Information Technology  
Address: Bd. Vasile Pârvan, No. 2, 300223, Timisoara  
Phone: (+40) 256 403 278  
E-mail: mihai.udrescu-milosav@upt.ro

## AUTOMATED RECOVERY OF ARCHITECTURAL INFORMATION FROM SOURCE CODE (AREAS)

### Goal of the project:

The goal of the project is to develop and validate automatic recovery methods of the architectural information from the code, which is an important activity for program comprehension. Program comprehension, an essential prerequisite for any maintenance activities, consumes a significant part of software budgets. Supporting the program comprehension activity by intelligent tools is an important mechanism for cost reduction.

### Short description of the project:

The project developed the AREAS technology, which comprises: establishing the primary artifacts that must be considered in the recovery process, the framework that captures which are the relevant relationships between them, and the algorithms that work best for abstracting or extracting architectural information.

### Project implemented by

The project was implemented by a team from the Department of Computer and Information Technology, Politehnica University Timișoara.

### Implementation period:

August 2017–December 2018

### Main activities:

Phase 1 activities:

- A1.1. The development of initial methods for architectural information recovery from the source code
- A1.2. The development of the experimental methodology and of the evaluation tools for the experimental results
- A1.3. The design of the software tool prototype architecture
- A1.4. The enhancement and extension of the architectural information extraction methods from the source code

Phase 2 activities:

- A2.1. Test Case selection and preprocessing
- A2.2. Experimental validation of the architectural information recovery methods
- A2.3. The development and integration of architectural components of the AREAS software tool prototype
- A2.4. Validation of the integrated recovery technology of the architectural information from the source code
- A2.5. AREAS software tool validation
- A2.6. Results dissemination

### Results:

Following results were obtained:

1. Development of methods for recovery of architectural information. This comprises: identifying the primary artifacts that must be considered for a successful recovery process and the relevant relationships between them, and development and synergic combination of the best algorithms and techniques from both the extractive and abstractive approaches.
2. Experimental validation of the methods for recovery of architectural information. This will also lead to creating a repository of test cases for architectural recovery from selected, analyzed and preprocessed relevant industry-size software systems, start a set of benchmarks for this domain.
3. Design, implementation and validation in the lab of the AREAS (Automated Recovery of Architectural Information from Source Code) tool and validation of the integrated AREAS technology for architectural recovery.

## Applicability and transferability of the results:

As a result of this project, the AREAS (Automated Recovery of Architectural information from Source code) technology was advanced from TRL2 (technology concept formulated) at the beginning of the project to TRL4 (technology validated in the lab) at the end of the project. The project produced documented experimental results validating the proposed methods on extensive case studies. The project has built a prototype of the integrated AREAS tool, having the architectural design and main components integrated and functionally validated by applying the tool on a set of relevant industry-size software systems.

## Financed through/by

This project was supported by a grant of the Romanian National Authority for Scientific Research and Innovation, UEFISCDI, project number PN-III-P2-2.1-PED-2016-0999.

## Research team

Assoc. Prof. Ioana SORA, PhD  
Assoc. Prof. Doru TODINCA, PhD  
Assist. Prof. Cosmin CERNAZANU, PhD  
Assoc. Prof. Ciprian-BOGDAN CHIRILA, PhD

## Contact information

Assoc. Prof. Ioana SORA, PhD  
Faculty of Automatics and Computers  
Department of Computer and Information Technology,  
Politehnica University Timișoara,  
Address: Vasile Pârvan Bvd. 2, 300223 Timisoara, Romania  
E-mail: ioana.sora@cs.upt.ro  
Web: <http://staff.cs.upt.ro/~ioana/areas>

## EXPERIMENTAL ASSESSMENT OF A SELF-ADAPTIVE INTELLIGENT TRANSPORTATION SYSTEM

### Goal of the project

At present, all attempts to optimize traffic flow completely ignore the fact that traffic has a predominant social footprint and would therefore potentially benefit from using specific tools to better understand its dynamics and predict its patterns (and thus introduce intelligence). We therefore aim towards designing a distributed, hierarchical, self-adaptive decision-making that would respond quickly to traffic changes based on optimization carried over communities and superior estimation of its patterns.

### Short description of the project

Our systems will: provide local optimizations, allow traffic lights to be networked, and provide global optimizations of traffic flow using decentralized, distributed control.

### Project implemented by

Politehnica University Timișoara

### Implementation period

Oct. 2017 – Dec. 2018

### Main activities

- Collecting data for urban traffic flow by using semi-permanent sensors
- Modelling existing transport infrastructure with respect to measured traffic values
- Software implementation of algorithms described in Cristian Cosariu's PhD thesis
- Porting the bio-inspired algorithm corresponding to a single node to an embedded platform for implementation on a traffic controller
- Comparative simulation with a before-after analysis of the main quality indicators of the traffic
- High-level description for the architecture and communication framework for adjacent intersections
- Validation by simulation with special tools for the described protocol
- Extensive testing of the embedded platform under realistic operating conditions to achieve 1 year availability
- Participation to at least 2 international conferences

### Results

- Development and online publication of the project's website
- Procurement of hardware and software required for the implementation of the project
- Technical documents with actual traffic values for road segments
- Architectural diagrams and specifications of proposed protocol with validation through simulation
- Source code and standard description of proposed methodology, available online on the project's website

#### Conference papers:

1. Gabriel Baban, Alexandru Iovanovici, Cristian Cosariu, Lucian Prodan.. Determination of the Critical Congestion Point in Urban Traffic Networks: A Case Study. 2017 IEEE 14th International Scientific Conference on Informatics, Poprad, Slovak Republic, November 14 - 16, 2017, doi 10.1109/informatics.2017.8327215.
2. Gabriel Baban, Alexandru Iovanovici, Cristian Cosariu, Lucian Prodan.. High Betweenness Nodes and Crowded Intersections: An Experimental Assessment by Means of Simulation. IEEE 12th International Symposium on Applied Computational Intelligence and Informatics (SACI 2018), May 17-19, 2018, Timisoara, Romania.

## Applicability and transferability of the results

Our algorithm quickly reacts to traffic dynamics based on local heuristics. Real traffic situations simulated using the Vissim software showed a decrease in waiting times and queue lengths at local intersection level. The algorithm can be mapped efficiently onto embedded devices, current TRL-3 standing.

Our SIGS methodology recreates the road network by changing lane directions by using genetic algorithms and also has a current TRL-3 standing.

Intersections will exchange local traffic values and allow genetic algorithms to provide optimizations, which brings this at TRL-2. This will provide distributed, self-adaptive optimization of traffic.

## Financed through/by

UEFISCDI PN-III-P2-2.1-PED-2016-1518, nr. 221PED/2017

## Research centre

- Politehnica University Timișoara, Faculty of Automation and Computing
- Research Center in Computer and Information Technology (CCCTI)
- Advanced Computing Systems and Architectures Laboratory

## Research team

Lucian PRODAN,  
Alexandru IOVANOVICI,  
Cristian COSARIU,  
Mihai UDRESCU,  
Alexandru TOPIRCEANU,  
Iosif SZEIDERT,  
Flavius OPRITOIU,  
Gabriel BABAN,  
Dacian AVRAMONI

## Contact information

Assoc. Prof. Lucian PRODAN, PhD  
Faculty of Automation and Computing  
Department of Computer and Software Engineering  
Address: 2 Vasile Parvan, RO-300223 Timisoara  
Phone: (+40) 256 403 278  
E-mail: lucian.prodan@upt.ro  
Web: wikitrafic.cs.upt.ro



## IMPROVING THE PREDICTION OF OPINION DYNAMICS IN TEMPORAL SOCIAL NETWORKS: MATHEMATICAL MODELING AND SIMULATION FRAMEWORK

### Goal of the project

Improving the prediction of opinion distribution in a target society by means of topological analysis, temporal and spatial distribution of opinion sources, and real-time simulation on empirically gathered data. As such, we define the following individual objectives:

- 1) Topological analysis of empirical social network data to understand how interconnection patterns of individuals and communities influence the spread of opinion.
- 2) Development of an innovative social interaction model, inspired by previous original work, considering the temporal aspect of opinion sources.
- 3) Definition of a strategy for real-time opinion seed selection by means of node and edge centrality distribution.
- 4) Synergy of results from objectives 1-3 with direct applicative socio-economic impact by developing a crowdsourcing web-platform for voting and gathering anonymized empirical data from citizens.

### Short description of the project

In the wake of big data analytics, this project sets out to push the boundaries of scientific understanding of opinion dynamics in social networks by analyzing how the underlying network topology influences communication patterns and the polarization of opinion.

### Project implemented by

Assist. Prof. Alexandru TOPÎRCEANU – responsible for outlining the research goals, modeling of experiments, simulation and data validation, writing scientific manuscripts, overall project management.

Prof. Radu-Emil PRECUP – mentor for the project director, research goals, experiment modeling, revising scientific manuscripts.

Denis Nuțiu (4th year student) – web platform implementation.

### Implementation period

02.05.2018 – 30.11.2019 (19 months)

### Main activities

This project comes to improve our understanding of opinion diffusion in emergent social networks. Consequently, to build models that are aware of these phenomena, we propose a topological analysis of empirical data using network motifs, community detection algorithms and statistics to understand the behavioral patterns and centralities which have an impact on the spatial and temporal distribution of opinion.

As opposed to most existing opinion interaction models, we propose a temporal opinion injection model which evolves over time according to basic human traits and underlying social topology. Below is a schematic exemplifying the two different approaches considered.

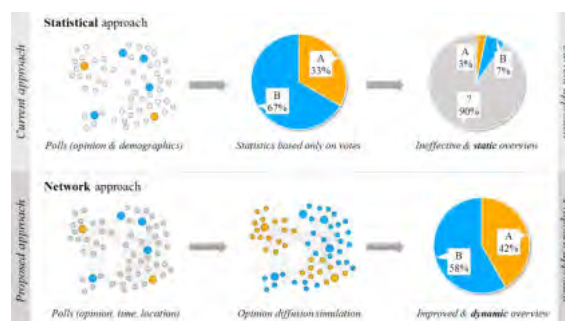

In the above figure we showcase the impact of the proposed project methodology in perspective to the current statistical approaches in opinion poll analysis and prediction. The statistical method relies solely on a small subset of individuals from which it tries to extrapolate overall opinion distribution; however, most of the opinion remains unknown (see gray pie chart in upper panel). Our proposed approach implies simulation of opinion propagation using more reliable scientific models and thus yields a more accurate perspective of opinion distribution (lower panel).

## Results

We make use of temporal microscopic diffusion models to predict the macroscopic response of a target society being targeted by opinion injection. Our results pinpoint to the fact that time-awareness is more significant in poll prediction performance than previously considered.

Below, we exemplify a snapshot of the poll evolution calculated for the 2016 US presidential pre-election period. We provide snapshots of the final period before elections using cumulative counting (A), and our time-aware method (B) to estimate polls. Here, we exemplify the relative differences (Clinton–Trump) in polls at several time points.

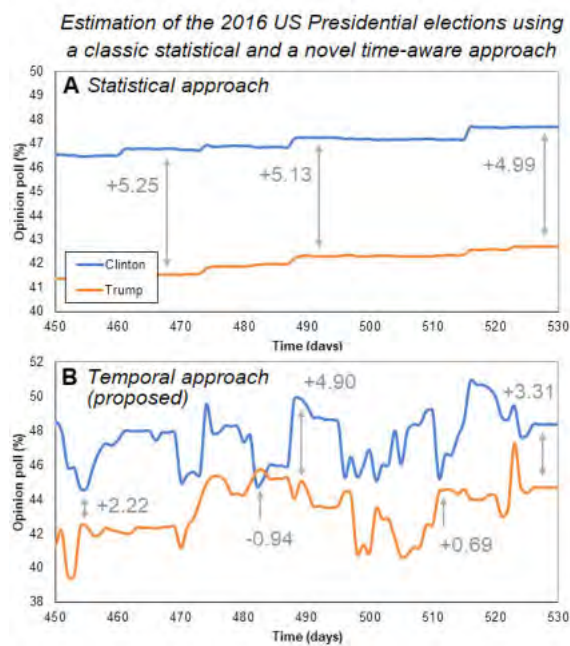

For the 2012 US elections we can approximate the final poll results within a 2% margin, while current approaches produce much greater offsets of about 7%. Similarly, for the 2016 elections, our method (TA) manages to come within 1.5% of the real election results, while the current statistical approach (SA) remains outside the 4% margin. In terms of quantifying the overall performance boost of our method, compared to the benchmark methods, TA proves to be 75% more accurate for the 2012 elections, respectively 74% for estimating the 2016 elections.

As an explanation to why our TA method has a superior prediction capability is that, by taking into consideration the timing of pre-election opinion injection, TA captures the momentum of candidate popularity.

## Applicability and transferability of the results

Current state of the art solutions for prediction, employed by respectable institutions in the US, like the *Huffington Post*, *Real Clear Politics*, or *Five Thirty Eight*, employ poll counting and combining polls with economic indices. Nevertheless, we have not seen any time-aware method that is similar to the one proposed by us in this project.

Consequently, we consider the framework developed in this project as very encouraging, and possibly opening a new line of research to further perfect our initial proposed method, which, to the best of our knowledge, is original and new. We hope to pave a new path of research targeting dynamic and temporal social network analysis, with immediate applicability in real-world systems where the needs for predictability and control are paramount.

## Financed through/by

Romanian National Authority for Scientific Research and Innovation (UEFISCDI), project number PN-III-P1-1.1-PD-2016-0193

## Research centre

- CCCTI: Research Centre for Computers and Information Technology (UPT)
- ACSA: Advanced computing systems and architectures research group

## Research team

Director – Assist. Prof. Alexandru TOPÎRCEANU, PhD

Mentor – Prof. Radu-Emil PRECUP, PhD

## Contact information

Assist. Prof. Alexandru TOPÎRCEANU, PhD

Faculty of Automation and Computing

Department of Computer and Information Technology

Address: 2, Vasile Pârvan Bvd., 300223, Timișoara

Phone: +40 256 403261

E-mail: alex.topirceanu@cs.upt.ro

Web: <http://staff.cs.upt.ro/~alex/>

Project website: [staff.cs.upt.ro/~alex/projects/impress/site/](http://staff.cs.upt.ro/~alex/projects/impress/site/)

## COMPREHENSIVE MONITORING METHODOLOGY FOR AGRICULTURAL LAND USE DYNAMIC CHANGES USING MULTISOURCE REMOTE SENSING DATA – AGRITELD

### Goal of the project

The scientific study of agricultural lands is found in the specialty literature since the 1930s. These studies gradually turn from traditional studies (field investigations, field studies and then laboratory) to 3s spatially-based technology. The Integrated Approach to 3s Technology represents trends in precision farming. In this respect, in Europe and beyond, the factors responsible for the rational and sustainable management of agricultural land (governments) gradually achieve the importance of “remote” monitoring of agricultural lands and the importance of studying them globally.

### Short description of the project

Information acquisitioned by remote sensing facilitate rapid and effective quantification of changes or advances a plant or several plants have encountered, their development phases and the basis for a new perception of research into precision farming.

Research and agricultural land monitoring using the benefits of remote sensing has developed a lot in recent years, but there are still unresolved issues related to: remote monitoring of a wide range of species (high variety), high accuracy, quasi-reality is still at the operating stage etc.

Information acquisitioned by remote sensing facilitate rapid and effective quantification of changes or advances a plant or several plants have encountered, their development phases and the basis for a new perception of research into precision farming.

Research and agricultural land monitoring using the benefits of remote sensing has developed a lot in recent years, but there are still unresolved issues related to: remote monitoring of a wide range of species (high variety), high accuracy, quasi-reality is still at the operating stage etc.

### Project implemented by

#### Beneficiary:

Politehnica University Timișoara

Department: Overland Communication Ways, Foundations and Cadastral Survey

#### Partner:

Chinese Academy of Science

Institute of Remote Sensing and Digital Earth

### Implementation period

June 2018 – December 2019

### Main activities

Through the cooperation, we wish to form a systematic method to monitor the agricultural land use quickly and accurately, build up the remote sensing model of agricultural land use change assessment, prediction and spatial optimization. This could support centralized and orderly management of agricultural land, which provides scientific basis for agricultural land.

As originality and innovation elements following objective can be specified:

1. Developing multi-source remote sensing data fusion technology, and increasing the accuracy of land field determinations;
2. Developing a comprehensive monitoring technology based on multi-source remote sensing analysis of dynamic change of agricultural land use;
3. Establishing and validating an assessment, prediction and spatial optimization model of agricultural land use change using GIS facilities (Vilceanu, Herban and Meng 2017);

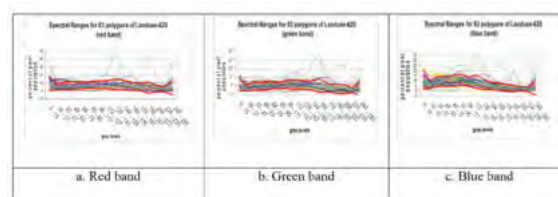

Fig. 1 GIS-Driven - Detectarea schimbărilor

There are several objectives standing before us. The cooperation in itself is a very positive goal as it opens each team to: other regions; different angles, view and facets of agricultural management; and different ways of thinking. More specifically, the cooperation proposed here between China and Romania is envisaged to help with introducing each other with the technology of monitoring and of land classification with high precision, as done at the other country.

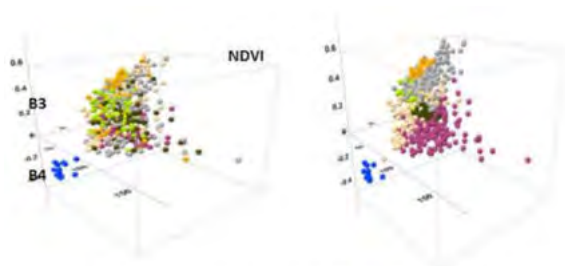

Fig. 2 IDA change detection and classification (left-before, right- after)

A secondary objective would be realizing better the usage of the spatial information embedded in the satellite images for the advancement of agricultural technology. The concept of GIS-Driven / GIS-support, mentioned above, is clearly one of the clear cut tools for such endeavour. In addition, both teams set some more specific goals:

- To learn the special characteristics of the satellite images provided by the Chinese cartographic satellite and any other products that will be provided for parallel processing.
- To establish the minimal resolution needed for the change detection and agricultural related classification at hand.
- To develop a modular concept of methodology that will support future adaptation to new satellite sources.

## Results

- Developing a fusion technology of remote sensing data acquired from multiple sources;
- Developing a smart monitoring method based on dynamic changes of agricultural lands analysis from multiple sources of remote sensing;
- Establishing and validating an assessment, prediction and spatial optimization model of agricultural land use changes;
- Integrating spatial information in GIS platforms.

## Applicability and transferability of the results

Applicability of the study its very various and useful for:

- Governments - implementing agricultural smart polities;
- small and large agricultural farms;
- another areas of research like forestry;
- etc..

## Financed through/by

PN-III- Program: European and International Cooperation

## Research Centre

Infrastructure for Construction and Transportation

## Research team

Prof. Sorin HERBAN, PhD  
 Prof. Carmen GRECEA, PhD  
 Assist. Prof.. Beatrice VILCEANU, PhD  
 Assist. Prof. Rares HALBAC, PhD  
 Adrian ALIONESCU, PhD Student  
 Anca MORARESCU, PhD Student

## Contact information

Prof. Sorin HERBAN, PhD  
 Faculty of Civil Engineering  
 Department of Overland Communication Ways, Foundations and Cadastral Survey  
 Address: str. Traian Lalescu, St, 2A, Timisoara

## SOLAR LIGHT- ACTIVATED NANO-TiO<sub>2</sub> DOPED WITH SILVER-COVERED ACTIVATED CARBON AND ZEOLITE BASED PHOTOCATALYTICALLY-ASSISTED FILTERING SYSTEM FOR WATER TREATMENT (WATICAZ)

### Goal of the project:

The WATICAZ project scope is to develop an innovative water treatment unit characterized by enhanced performance consisted of the photocatalysis-assisted filtering system (PFS) as experimental demonstrator at laboratory scale for the treatment of real drinking water source. This system should exhibit the bifunctional adsorptive and photocatalytic characteristics that can be exploited either as filtering system with the possibility of solar photocatalytic regeneration (SPR) or as advanced oxidation unit to remove/degrade a large range of contaminants from water.

### Short description of the project

The photocatalytic-assisted filtering unit using (doped)TiO<sub>2</sub>-covered activated carbon/zeolite operated under UV/solar irradiation is developed.

### Project implemented by

Partnership between Politehnica University Timișoara and National Institute for Research and Development for Electrochemistry and Condensed Matter

### Implementation period

03.01.2017–29.06.2018

### Main activities

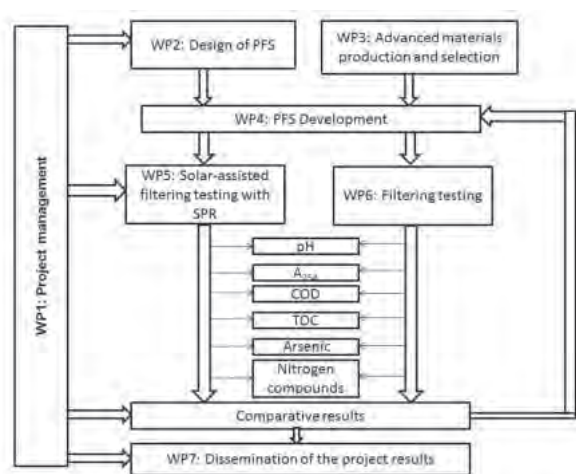

Project flow chart with work packages (WPs)

The main work packages and tasks are:

- Project management;
- Design of photocatalysis-assisted filtering system (PFS);
- Filtering materials production and selection (*Synthesis of the filtering materials characterized by the photocatalysis activity; Characterization of filtering materials by XRD, SEM, AFM, BET, DRUV-VIS*);
- (Solar-assisted) filtering testing (with solar photocatalytic regeneration - SPR) (*Filtering column filling; Functional and operational testing of (solar irradiation photocatalysis-assisted) filtering system; Filtering material regeneration under solar irradiation; Morpho-structural characterization of materials after its usage; Validation by testing for the treatment of the real drinking water source*);
- Dissemination of the results.

### Results

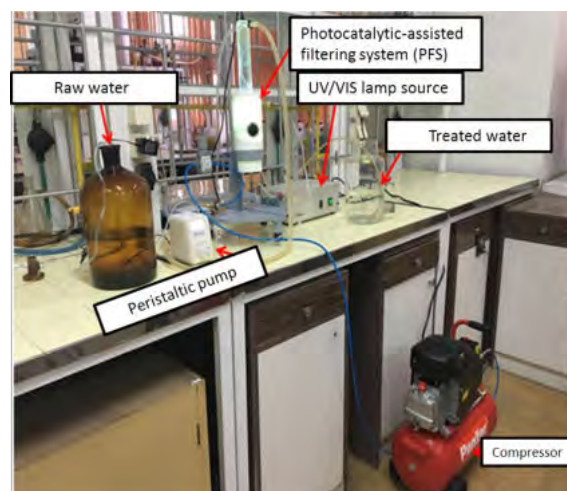

Photocatalysis-assisted filtering unit

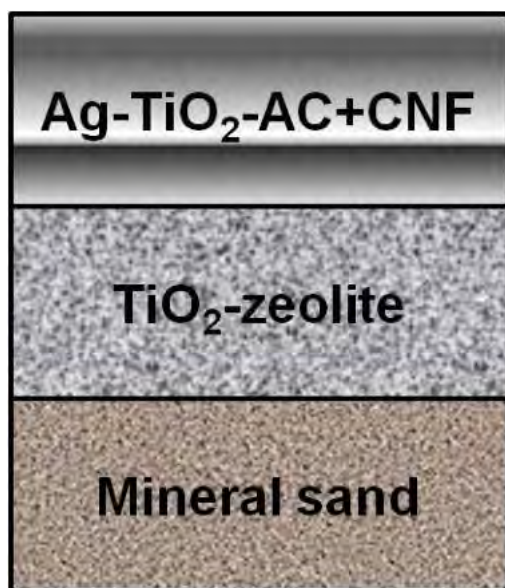

Layers of materials in filtering column

## Applicability and transferability of the results

Drinking water and wastewater treatment plants

## Financed through/by

Executive Agency for Higher Education, Research, Development and Innovation Funding (UEFISCDI)

## Research Center

Research Center of Environmental Science and Engineering

## Research team

Prof. Florica MANEA, PhD  
Prof. Rodica PODE, PhD  
Prof. Vasile PODE, PhD  
Assist. Prof. Andra TAMAS, PhD  
Assist. Prof. Aniela POP, PhD  
Tehn. Eng. Lacrima-Crysty IGHIAN,  
Eng. Sorina NEGREA, Master student

## Contact information

Prof. Florica MANEA, PhD  
Faculty of Industrial Chemistry and Environmental Engineering  
Department of Applied Chemistry and Engineering of Inorganic  
Compounds and Environment  
VAddress: Vasile Parvan Sq. no. 6, 300223  
Phone: (+40) 256 403070  
Mobile: +40274506095  
E-mail: florica.manea@upt.ro  
Web: <http://www.chim.upt.ro/ro/cercetare/proiecte-de-cercetare/248-pn-iii-p2-2-1-ped-2016-0265>

## ADVANCED MATERIALS BASED ON COMBUSTION-SYNTHESIZED MAGNETIC IRON OXIDES NANOPARTICLES AND THEIR CYTOTOXICITY DESIGNED FOR CANCER TREATMENT

### Goal of the project:

- Obtaining of magnetic iron oxides nanoparticles using the combustion synthesis method and monitoring the influence of several working parameters: fuel type (EDTA, citric acid, glucose), oxidant/fuel molar ratio (fuel-rich compositions), ignition procedure (heating mantle, microwave field), working atmosphere (in air/no air), carbon and organic residues presence.
- Preparation of colloidal suspensions.
- The assessment of the toxicological profile/biological activity of the iron oxide colloidal suspensions on normal/tumour liver and kidney cell lines.

### Short description of the project

The project presents the preparation of iron oxides with via combustion synthesis and testing their selective cytotoxicity.

### Project implemented by

Department of Applied Chemistry and Engineering of Inorganic Compounds and Environment,  
Faculty of Industrial Chemistry and Environmental Engineering,  
Politehnica University Timișoara

### Implementation period

July 2017–December 2019

### Main activities

Combustion synthesis of magnetic iron oxides nanoparticles. The influence of several parameters on the powders characteristics were pursued:

- nature of the fuel: glucose, citric acid, EDTA, TWEEN 80, hexamethylenetetramine
- reaction conditions: presence and absence of air
- carbon and organic residues presence and chemical oxidation removal using  $H_2O_2$

Characterization of magnetic iron oxides nanoparticles:

- combustion reactions evolution was assessed by TG-DSC thermal investigations
- the phase composition of the synthesized compounds was investigated by XRD
- specific surface area (BET)
- FTIR spectroscopy

The obtained results were centralized and interpreted for recipes optimization.

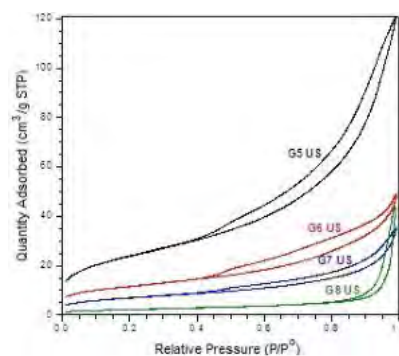
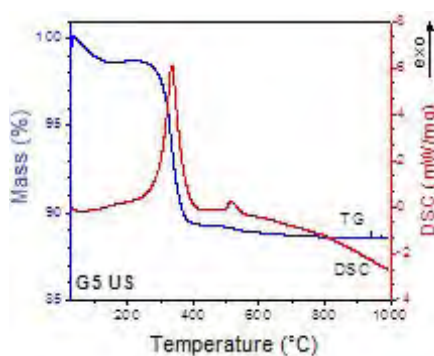
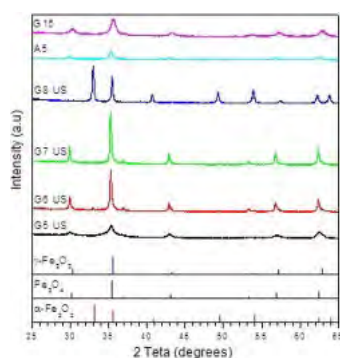

## Results:

Synthesis protocols and recipes for 31 samples prepared by combustion synthesis. It was established the influence of different fuels (glucose, citric acid, EDTA, TWEEN 80, hexamethylenetetramine) and of the reaction conditions on the synthesis of iron oxides with magnetic properties.

## Applicability and transferability of the results

These researches open an entirely new perspective on the potential use of combustion-synthesized iron oxide nanoparticles in cancer therapy by selective cytotoxicity.

The results will be subjected to a patent application.

## Financed through/by

Ministry of Research and Innovation, CNCS - UEFISCDI, project number PN-III-P4-ID-PCE-2016-0765, within PNCDI III

## Research Center

Research Centre for Inorganic Materials and Alternative Energies

## Research team

1. Cornelia Pacurariu - project leader
2. Cristina Dehelean - experienced researcher
3. Robert Ianos - experienced researcher
4. Radu Lazau - experienced researcher
5. Dorina Coricovac - postdoc researcher
6. Alina Moaca - postdoc researcher
7. Roxana Babuta (Racoviceanu) - postdoc researcher
8. Eliza Muntean - PhD student
9. Aylin Capraru - PhD student

## Contact information

Prof. Cornelia PĂCURARIU, PhD  
Faculty of Industrial Chemistry and Environmental Engineering  
Department of Applied Chemistry and Engineering of Inorganic Compounds and Environment  
Address: Bd.V. Pîrvan, No.6 Postal Code 300223, Timisoara  
Phone: (+40) 256 404 144  
Mobile: +40 722 54 75 18  
E-mail: cornelia.pacurariu@upt.ro  
Web: <http://www.chim.upt.ro/ro/caicam>



## INTEGRATED AND SUSTAINABLE PROCESSES FOR ENVIRONMENTAL CLEAN-UP, WASTEWATER REUSE AND WASTE VALORIZATION – SUSTENVPRO

### Goal of the project

The goal of complex project SUSTENVPRO is to increase the institutional performance in the ENVIRONMENT field of a consortium of 5 public research organizations with recognized research performances and one R&D National Institute under consolidation, through an integrative approach which supports/develop the existent research competencies of each partner and transfer capacities of results with applicative and innovative potential envisaging the elimination of priority pollutants from water using innovative advanced water/ wastewater treatment processes and waste recovery.

### Short description of the project

The complex project SUSTENVPRO consisted of 5 research component projects (PC):

PC 1. Complex evaluations of priority pollutants present in various water matrixes and risk identification on the ecosystems and human health;

PC 2. Water treatment processes optimization and development of innovative materials for the priority pollutants removal;

PC 3. Valorization of biomass resources for the development of innovative processes for wastewater treatment and priority pollutants removal;

PC 4. Metallic waste valorization for innovative wastewater treatment process development and removal of priority pollutants;

PC 5. Sustainability assessments of water/ wastewater treatment and waste valorization processes based on life cycle assessment.

### Project implemented by

The project is implemented by 4 universities and two national R&D institutes:

**Coordinator:** "Gheorghe Asachi" Technical University of Iasi;

**Partners:** Politehnica University of Bucharest; "Alexandru Iona Cuza" University of Iasi; Politehnica University Timișoara; "Petru Poni" Institute of Macromolecular Chemistry Iasi; National Research and Development Institute for Environmental Protection, Bucharest.

### Implementation period

2018 – 2020

### Main activities

- Developing and validating an innovative approach oriented to analysis, preventing and correcting the environmental risks associated with the presence of priority pollutants in various matrices of water use;
- Development of efficient innovative water treatment and advanced wastewater treatment processes in order to eliminate priority organic and inorganic pollutants in the anthropic water cycle;
- Development of new innovative materials (polymeric or composite materials) with properties designed according to the characteristics of the priority pollutants;
- Utilization of materials from organic (biomass) and inorganic waste (metallic waste) in innovative wastewater treatment processes for removing priority pollutants and recirculating / reusing water;
- Sustainability assessment of processes and products through Life Cycle Assessment tool.

### Results

- Research workplaces;
- New/significantly improved technologies /procedures;
- New/significantly improved research services;
- New research and technology consultancy services (uploaded on the ERRIS platform);
- Research services by sharing the research infrastructure among project partners (A1 and A2 research vouchers);
- Knowledge transfer to water operator through C voucher;
- Research papers published in ISI-ranked journals;
- Communications at national and international scientific events (conferences, exhibitions);
- Dissemination and technology transfer workshops;
- (Initiation /Intermediary /Final) Project workshops;
- RDI common program (in agreement with the institutional development plan of every partner).

## Applicability and transferability of the results

- Transferability of research results between consortium partners;
- Technological transfer of advanced water/wastewater treatment technologies/procedures to public and private economic environment (regional water operators, environmental companies, private companies in the water/waste field etc.); knowledge transfer to regional water operator through C voucher within the project framework tested at pilot scale as treatability study for concrete applications in drinking water treatment;
- Good practice guide for circular economy in water field for sustainability consulting company, non-profit organization, environmental agencies.

## Financed through/by

Executive Agency for Higher Education, Development and Innovation Funding (UEFISCDI)

## Research centre

Research Centre in Environmental Science and Engineering

## Research team

UPT Project Responsible: Prof.dr.eng. MANEA Florica  
Scientific Researcher, level I : PODE Rodica  
Scientific Researcher, level III: COCHECI Laura  
Scientific Researcher, level III: POP Aniela  
Scientific Researcher, level III: VODA Raluca  
Scientific Researcher, level III: BACIU Anamaria  
Development engineer: IGHIAN Lacrima-Crysty  
Development engineer: DELCIOIU Claudia

## Contact information

Prof. Florica MANEA, PhD  
Faculty of Industrial Chemistry and Environmental Engineering  
Department of Applied Chemistry and Engineering of Inorganic Compounds and Environment  
Address: Str.V. Parvan, No.6 300223, Timisoara  
Phone: (+40) 256 403069  
Mobile(+40)724506095  
E-mail: florica.manea@upt.ro  
Web: <http://sustenvpro.dimm.tuiasi.ro/>

## RECYCLABLE MULTILAYER MAGNETIC BIOCATALYST FOR SYNTHESIS OF NATURAL ESTERS

### Goal of the project:

The main goal of the project is to develop a demonstration model for a new biocatalyst containing a designed magnetic core and hybrid layers (organic and silica) that allow the immobilization of enzymes. The validation of the model will be accomplished through the effectiveness of the product in a specific reaction, to demonstrate that such a biocatalyst is stable, reproducible, recyclable and able to synthesize esters that are accepted as naturals according to the EC regulations (Regulation no 1334/2008 of the European Parliament and subsequent amendments).

### Short description of the project

The key objective is a comprehensive evaluation of the magnetic manipulation efficiency of enzyme functionalized magnetic nanocomposites obtained by applying cost-effective preparation procedures and manifold advanced characterization and testing techniques. The chemical composition, structure, size distribution, magneto- responsiveness and size, as well as the enzyme loading capability will be designed to fulfill the requirements for efficient biocatalysis and easy recovery of the enzyme even from viscous media, avoiding the contamination of the product and allowing its recognition as "food-grade".

An innovative multilayer technology will accomplish the demonstrative model. The immobilization of lipase on controlled-size magnetic core nanoparticles will be combined with stabilization of the hybrid composite through a sol-gel silica shell. The size and magnetic properties of the core particles will be adjusted to allow the optimal catalytic efficiency.

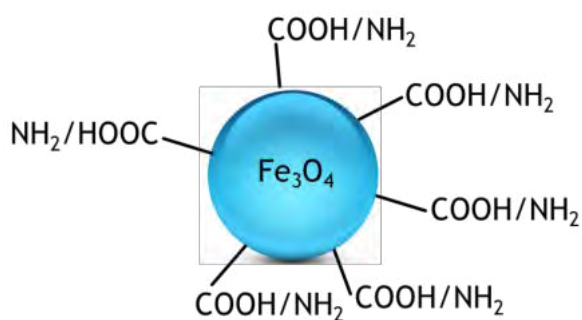

### Project implemented by

- Politehnica University Timișoara-Project leader
- National Institute for Research and Development of Isotopic and Molecular Technologies INCDTIM Cluj-Napoca - Project partner

### Implementation period

30.01.2017- 29.06.2018

### Main activities

The objective of the project is to develop a demonstration model for a new biocatalyst containing a designed magnetic core and hybrid layers (organic and silicon) that allow the immobilization of enzymes, as well as the validation of the model through its effectiveness in a specific reaction of aroma ester synthesis.

**Stage 1** (2017, 12 months) – Development of a new multilayer magnetic biocatalyst

**Stage 2** (2017, 12 month) – Synthesis of natural esters in repeated cycles using the multilayer magnetic biocatalyst

### Results

The research carried out in this stage was focused on:

- development of a new multilayer magnetic catalyst by preparation of various magnetic nanoparticles;
- immobilization studies of *Candida antarctica* B lipase on these supports;
- investigation of the resulted biocatalysts in esterification reactions. Magnetic clusters functionalized with amino and carboxyl groups were obtained, and their structural, morphological and their magnetic characteristics were determined by instrumental methods, like as XPS spectroscopy. A second direction was the production of single-core magnetic nanoparticles stabilized by coating with various surfactants. These nanoparticles were thoroughly characterized by FT-IR, TEM, and XPS.

For both multi-core and single-core magnetic particles, the hydrodynamic diameters and zeta potential values have been also determined. The investigations concerning lipase immobilization included the influence of the nature and concentration of the binding agent (carbodiimide or glutaraldehyde), as well as finding of the optimal reaction conditions for covalent binding. The hydrolytic and esterification activities of the obtained biocatalysts were assayed on standard substrates.

Visit also: <http://chim.upt.ro/ro/cercetare/proiecte-de-cercetare/247-pn-iii-p2-2-1-ped-2016-0168>

#### Publications in the field of the project:

1. A. Nan, I.V. Ganea, R. Turcu, Physicochemical properties of a new magnetic nanostructure based on poly(benzofurane-co-arylacetic acid), *Analytical Letters*, accepted, DOI: 10.1080/00032719.2017.1400041
2. A. Todea, D. Aparaschivei, V. Badea, C.G. Boeriu, F. Peter, Biocatalytic route for the synthesis of oligoesters of hydroxy-fatty acids and  $\epsilon$ -caprolactone *Biotechnology Journal*, 2018, accepted.

#### Presentations at conferences:

1. R. Turcu, C. Vasilescu, A. Nan, T. Radu, I. Crăciunescu, A. Petran, M. Cîrcu, A. Bunge, F. Peter, Magnetic nanostructures with functional coating specifically designed for immobilization of enzymes, *2nd World Congress & Expo on Materials Science and Nanoscience*, September 25-27, Valencia, Spain.
2. C. Vasilescu, I. Benea, C. Paul, A. Todea, R. Turcu, F. Peter, Immobilization of lipase from *Candida antarctica* B by covalent binding onto magnetic supports, *New Trends and Strategies in the Chemistry of Advanced Materials with Relevance in Biological Systems, Technique and Environmental Protection*, 10th Edition, June 08-09, 2017, Timișoara, Romania.

#### Applicability and transferability of the results

This custom-made immobilized lipase will be able to catalyze the synthesis of natural esters from natural acids and natural alcohols. There is a high demand for food aroma esters recognized as naturals and the biocatalytic way is the best possibility to synthesize them. Superparamagnetic iron oxide nanoparticles (IONPs) in highly stable ferrofluid formulations will be used to fabricate functionalized magneto-responsive nanobeads for lipase immobilization, resulting in manifold reusable nanoparticle systems of high catalytic efficiency.

#### Financed through/by

Romanian Authority for Scientific Research and Innovation (UEFISCDI), project number PN-III-P2-2.1-PED-2016-0168, within PNCDI III

#### Research Center

Research Centre in Organic, Macromolecular and Natural Compounds Chemistry and Engineering

#### Research team

##### Consortium leader: Politehnica University Timișoara

Director: Prof. Francisc PETER, PHD

Members:

Eng. Anamaria TODEA, PhD

Eng. Cristina PAUL, PhD

Dr. Oana MARINICĂ

Iulia PĂUȘESCU, PhD

Chem. Diana APARASCHIVEI (PhD student)

Chem. Corina VASILESCU (PhD student)

Biol. Horațiu MOLDOVAN (PhD student)

##### Partner: National Institute for Research and Development of Isotopic and Molecular Technologies INCDTIM Cluj-Napoca

Responsible: Dr. Rodica TURCU

Dr. Alexander BUNGE

Dr. Monica CIRCU

Dr. Izabella CRĂCIUNESCU

Dr. Alexandra NAN

Dr. Anca Petran

Dr. Teodora Radu

#### Contact information

Prof. Francisc PETER, PhD

Faculty of Industrial Chemistry and Environmental Engineering

Department of Applied Chemistry and Engineering of Natural and Organic Compounds

Address: C. Telbisz str. 6, 300001 Timișoara, Romania

Phone: (+40) 256 404216

Mobile: (+40) 745637530

E-mail: francisc.peter@upt.ro

Web: chim.upt.ro

## ENERGY EFFICIENCY THROUGH AIR JETS ENERGY RECOVERY FROM EXHAUST SYSTEMS AT S.C. CLAGI-COPLASS S.R.L.

### Goal of the project

The project objective was focused on the climate change and energy consumption reduction issue through knowledge transfer to industry applications, based on the scientific and research activity of team members. Energy loss recovery measures applied to S.C. CLAGI COPLASS S.R.L. have contributed to the reduction of energy consumption.

### Short description of the project

Reducing energy consumption by recovering the energy exhausted into the atmosphere by the exhaust systems.

### Project implemented by

The project was implemented by the Politehnica University Timișoara at S.C. CLAGI COPLASS S.R.L.

### Implementation period

01.10.2016 - 01.10.2018

### Main activities

The activities were structured in three stages, as it follows:

**Stage I - Preparation, installation, and monitoring** - Within this stage, a database of energy consumptions was developed and for a group of 10 students an internship program was organized.

**Stage II - Analysis and implementation of the optimal system** - At this stage there were identified the sources with energy recoverable potential (thermographs and measurement of air jets velocities)- Figure 1-and recuperative solutions were implemented.

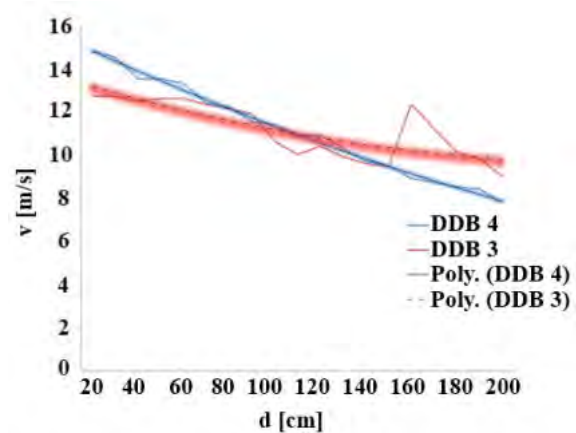
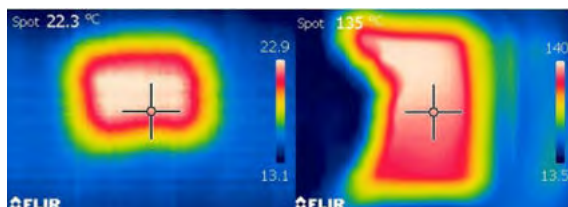

Figure 1

**Stage III - Analysis and optimization** - At this stage the optimal solution was analyzed, followed by the monitoring of the input / output parameters in order to establish the reduction of energy consumption at S.C. CLAGI COPLASS S.R.L. (Figure 2). The obtained results were validated by the economic agent.



Figure 2

### Results

The implementation of the proposed system has led to the optimization of installations for the industrial technological equipment such as dyeing / drying booths (DDB), and savings due to the energy consumption reduction (Figure 3).

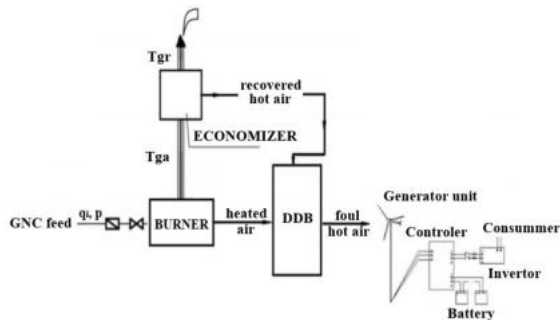

Figure 3

The technological improvement of the industrial technological equipment is an important factor for the economic agent to acquire new technical knowledge and increase the productivity. The members of the research team and the students / master students participating in the internship program have acquired entrepreneurial knowledge and skills.

The most significant result is the recovery of the quantified lost energy by reducing energy consumption (Figure 4) and, finally, the reduction of greenhouse gas emissions.

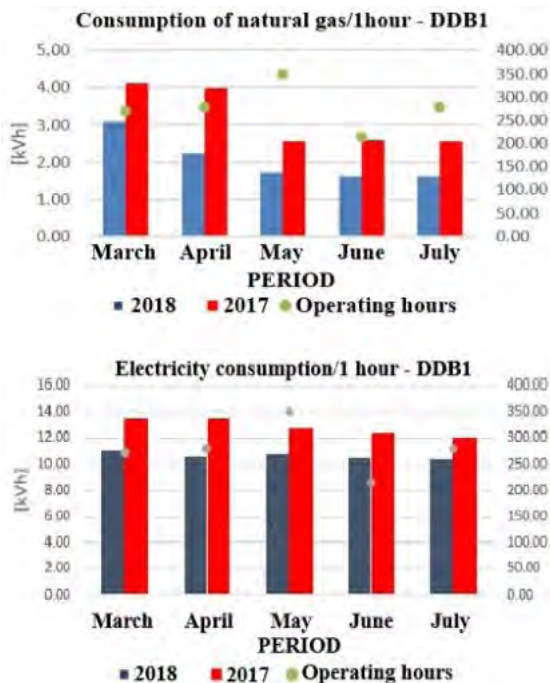

Figure 4

The scientific work impact of the research team members has been materialized through the publication of the research results in ISI / BDI indexed journals / conferences.

## Applicability and transferability of the results

Energy efficiency measurements, by addressing one-off solutions, have led to the energy consumption reduction and, implicitly, to lower production costs at the economic agent. By implementing the project, collaboration between the partners involved has been developed. The economic agent can extend the solution applicability to all technological endowments. Energy efficiency solutions can be extended and can have a multiplier effect for the industrial sector that has similar technological equipment.

## Financed through/by

Financed through PNCDI III - Program 2, Subprogram 2.1 – Transfer of knowledge to the economic agent, „Bridge Grant“ / by UEFISCDI

## Research Centre

Research Centre for Building Services Engineering (RCBSE)

## Research team

Project Manager  
Assoc. Prof.dr.eng. Adriana TOKAR

Researchers  
Assoc. Prof.Arina NEGOIȚESCU, PhD  
Assoc. Prof. Dan NEGOIȚESCU, PhD  
Assoc. Prof. Silvana BRATA, PhD  
Assist. Prof. Marius ADAM, PhD

## Contact information

Assoc. Prof. Adriana TOKAR, PhD  
Faculty of Civil Engineering  
Department of Civil Engineering and Equipments  
Address: Traian Lalescu Street, No.2, 300223, Timisoara  
Phone: (+40) 256 40X XXX  
Mobile: 0763689639  
E-mail: adriana.tokar@upt.ro  
Web: <http://www.ct.upt.ro/cci/index.htm>

## EXPERIMENTAL VALIDATION OF THE RESPONSE OF A FULL SCALE FRAME BUILDING SUBJECTED TO BLAST LOAD - FRAMEBLAST

### Goal of the project

The main goal of the FRAMEBLAST project is to provide an accurate validation of the response of a full scale building structural frame system under internal and external blasts in laboratory environment. The structure is subjected to internal and external blasts from different charge weights and locations (standoff, height above ground), resulting in different loading scenarios.

### Short description of the project

Explosions produced in urban areas by the detonation of high explosives are low-probability, but high-risk events. When they occur in the immediate vicinity of buildings, the explosions can affect their structural integrity (local/global failure) and harm people (injuries, death). Because the blast threat can only be mitigated, the risk can be reduced by reducing the exposure and vulnerability (enhanced local strength, allow the development of alternate load paths to prevent progressive collapse).

### Project implemented by

The project is implemented by a partnership between POLITEHNICA UNIVERSITY TIMIȘOARA, project coordinator Professor Florea Dinu and NATIONAL INSTITUTE FOR RESEARCH AND DEVELOPMENT IN MINE SAFETY AND PROTECTION TO EXPLOSION INSEMEX Petrosani, represented by dr.ing. Attila Kovacs. External experts from TECHNICAL UNIVERSITY of CLUJ-NAPOCA and URBAN-INCERC Cluj-Napoca are also involved.

### Implementation period

2017-2018

### Main activities

- Preliminary analysis, design and fabrication of full scale experimental model
- Experimental tests on full-scale building model under internal blast. Explosive charges are detonated in different locations to acquire information about blast pressure decay and interaction with the structure
- Experimental tests on full-scale building model under external blast. First explosive charges are detonated in different locations to acquire information about blast pressure decay and interaction with the structure. Second test series use increasing explosive charges (charge weight / standoff distance) to cause the column in proximity to fail.
- Validation of a numerical model using Extreme Loading for Structures (Applied Science International, LLC, ASI).
- The development of a procedure to apply structural identification to components of a full-scale building structure with structural damage resulting from the blast pressure.

### Results

1. Construction phase
  - The structure components were brought to the construction site and assembled on-site using bolted connections
  - Preliminary internal blast testing were performed using small charge weights (121 g cartridge of explosive)

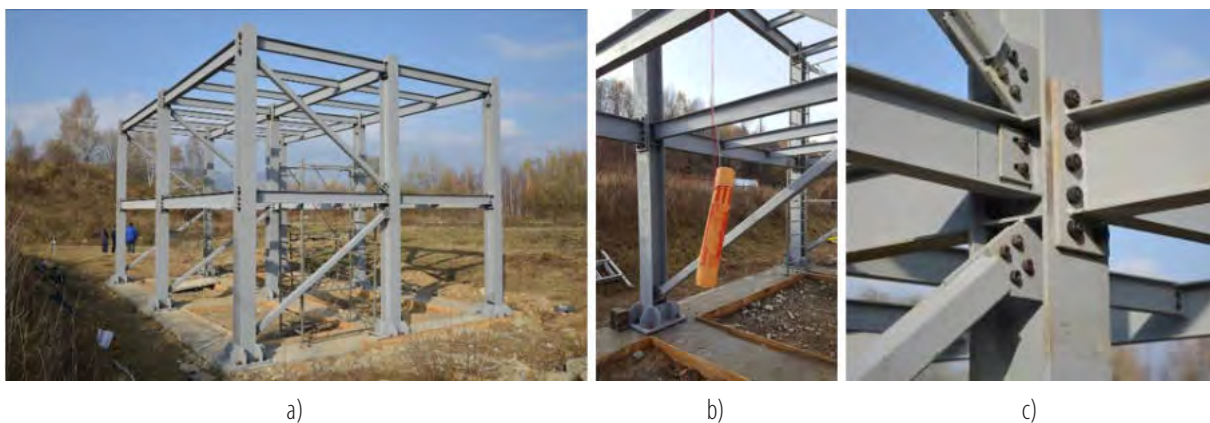

Fig. 1 Views with the experimental model:  
a) general view; b) view from inside with the position of a test blast charge; c) detailed view of a connection.

2. Experimental modal analysis to assess the dynamic properties of the structure (Bruel & Kjaer vibration measurement technology and equipment)
  - Experimental modal analyses (EMA) were carried out using hammer excitation and 11 accelerometers
  - The modal parameters were verified using the Modal Assurance Criterion (MAC)

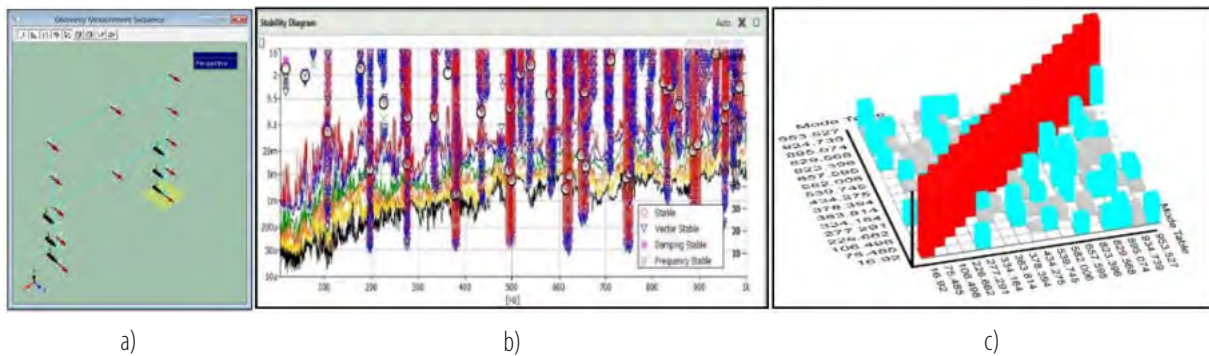

Fig. 2 Modal parameter identification: a) position of the accelerometers and MTC hammer; b) stability diagram; c) modal assurance criterion MAC

3. Preliminary numerical testing using models calibrated against bunker tests
  - Blast tests performed on two identical 3D specimen were extracted from a typical moment resisting steel frame structure
  - They allowed to make a preliminary calibration of the numerical model of a full scale building structural frame system
  - Numerical simulations were performed to evaluate the consequences of close-in detonations on the structural elements

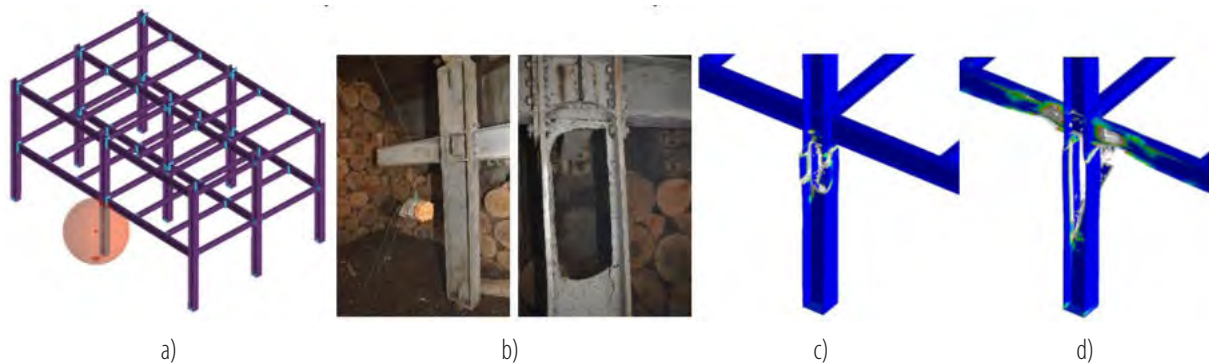

Fig. 3 Numerical simulations using ELS:

- a) 3D view of the model tested against external blast; b) relevant blast test inside bunker; c) - d) simulation of local damage for two blast loads

### Applicability and transferability of the results

- Experimental validation of an integrated building system in laboratory environment represents the bridge from the scientific research to practical application (structural engineering).
- Experimental database and numerical models are used to upgrade the existing codes for structural design and prevention measures

### Financed through/by

This work was supported by a grant of the Romanian National Authority for Scientific Research and Innovation, CNCS/CCCDI - UEFISCDI, project number PN-III-P2-2.1-PED-2016-0962, within PNCDI III: "Experimental validation of the response of a full-scale frame building subjected to blast load" - FRAMEBLAST (2017-2018).

### Research Centre

The Research Center for Mechanics of Materials and Structural Safety - CEMSIG

### Research Team

Prof. Florea DINU, PhD (Coordinator) Assist. Calin NEAGU, PhD  
 Academician Dan DUBINA, Assoc. Prof. Aurel STRATAN, PhD  
 Assist. Ioan MARGINEAN, PhD Prof. Raul ZAHARIA, PhD  
 Prof. Adrian CIUTINA, PhD Prof. Marin MARIN, PhD  
 Florin MIRON, PhD

### Contact information

Prof. Florea DINU, PhD  
 Faculty of Civil Engineering  
 Department of Steel Structures and Structural Mechanics CMMC  
 Address: Str. Ioan Curea 1, 300224, Timișoara  
 Phone: (+40) 256 403 912, Mobile: (+40) 722 460 349  
 E-mail: florea.dinu@upt.ro  
 Web: www.ct.upt.ro/centre/cemsig/frameblast.htm



## FAST WELDING COLD-FORMED STEEL BEAMS OF CORRUGATED SHEET WEB (WELLFORMED)

### Goal of the project

The main aim of the project is to test and validate a NEW technological solution for built-up cold-formed steel beams (CWB), with corrugated sheet webs and built-up cold-formed steel flanges, using Spot welding (SW) or Cold Metal Transfer (CMT) connecting technologies.

### Short description of the project

The advances in cold-formed steel structures require not only material savings but also high efficiency of production and manpower reduction. The WELLFORMED research project proposes to study a new technological solution for built-up beams made of corrugated steel sheets for the web and thin-walled cold-formed steel profiles for the flanges, connected by SW or CMT welding. Within the research project, the experimental work includes tensile-shear tests on the lap joint spot-welded specimens, were different combinations of steel sheets with various thicknesses were tested and, tests on full scale beams in bending. The study intends to demonstrate the feasibility of the proposed solutions, to assess their performance and to enlarge the knowledge by using numerical simulations for the optimization of the current solution and to define the limits of applicability of the solution.

### Project implemented by

CEMSIG - The Research Center for Mechanics of Materials and Structural Safety - Research and Technical Development unit of Politehnica University Timișoara, at the Faculty of Civil Engineering, Department of Steel Structures and Structural Mechanics.

### Implementation period

03.01.2017-02.07.2018

### Main activities

- design and fabrication of experimental program;
- experimental program on welded connections (SW and CMT) and optimisation of fastening technology;
- experimental program on full scale CWB beams, using SW or CMT connecting technologies;
- numerical investigation of beams and parametric investigations:
  - calibration of numerical models by experimental tests;
  - optimization of technical solutions;
  - design and numerical analysis of specimens with larger spans;
- design guidelines and recommendations for fabrication.

### Results

- experimental results on tensile-shear tests on the lap joint spot-welded and CMT specimens (280 small specimens), were different combinations of steel sheets with various thicknesses were tested;
- experimental program on 5 full scale CWB beams, 2 using SW and 3 CMT connecting technologies.

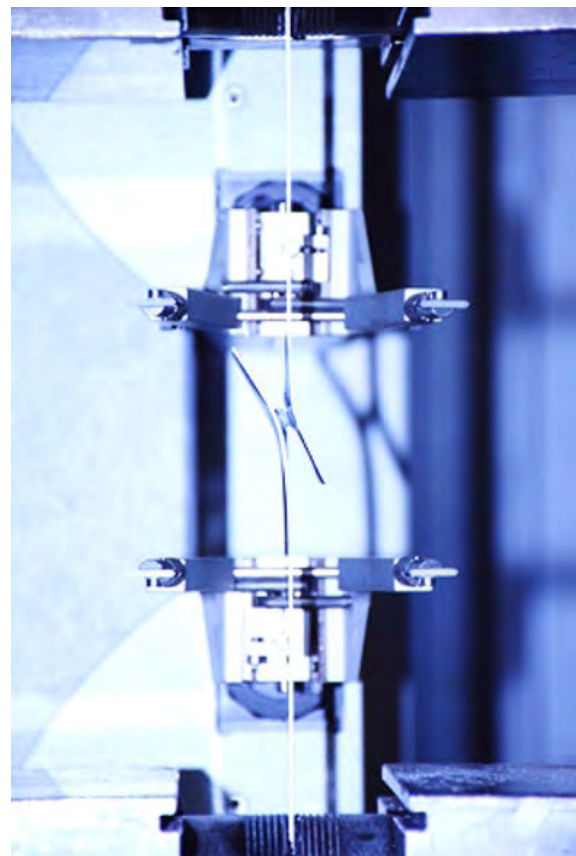

Fig. 1: Full button pull-out failure mode



Fig. 2: SW1 CWB Beam during the test

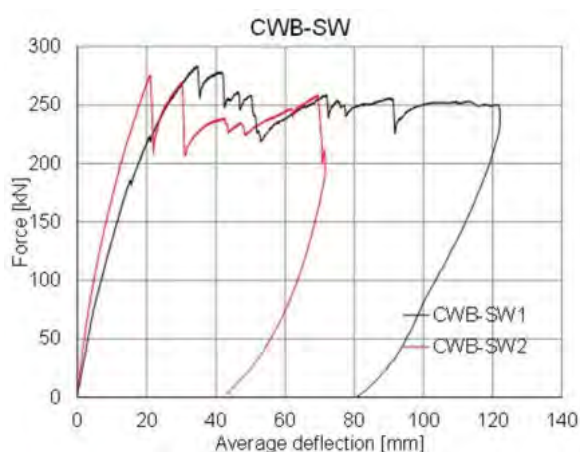

Fig. 3: Force-deflection curve for the full scale built-up beams

## Applicability and transferability of the results

The new technical solution is composed of 100% of cold-formed steel components, having high protection to corrosion, due to the fact that all components are galvanised. The solution allows for easy prefabrication, reduced erection time, mass production and high-precision quality control. All of these characteristics are expected to be interesting both for manufacturers and contractors, making steel competitive. Design guidelines and recommendations for fabrication will be provided.

## Financed through/by

The project is supported by a grant of the Executive Unit for Financing Higher Education, Research, Development and Innovation (UEFISCDI), grant agreement 57PED/2017.

## Research centre

Research Center for Mechanics of Materials and Structural Safety (CEMSIG)

## Research team

Prof. Viorel UNGUREANU, PhD  
 Acad. Dan DUBINA, PhD  
 Assist. prof. Mircea GEORGESCU, PhD  
 Assist. prof. Bogdan RADU, PhD  
 Assoc. prof. Mircea BURCA, PhD  
 Assoc. prof. Daniel TUNEA, PhD  
 Assoc. prof. Ioan Both, PhD  
 Assist. Calin NEAGU, PhD  
 Marius GROSAN, PhD stud.

## Contact information

Prof. Viorel UNGUREANU, PhD  
 Faculty of Civil Engineering  
 Department of Steel Structures and Structural Mechanics  
 Address: Str. Ioan Curea, No. 1, 300224, Timișoara  
 Phone: (+40) 256 403912, Mobile: (+40) 740 137640  
 E-mail: viorel.ungureanu@upt.ro  
[http://www.ct.upt.ro/centre/cemsig/wellformed\\_en.htm](http://www.ct.upt.ro/centre/cemsig/wellformed_en.htm)

## ADVANCING RE-CENTRING ECCENTRICALLY BRACED FRAMES: NEW LINK TYPOLOGIES AND INFLUENCE OF REINFORCED CONCRETE SLAB (ARNIS)

### Goal of the project

To reduce the costs and downtime of a structure hit by an earthquake, removable links and re-centering capacity concepts may be implemented in a dual eccentrically braced structure. The project aims at extending the validation of re-centering capability and link replacement feasibility on extended end-plate typologies and also investigate more detailed the global and local influence of three-dimensional reinforced concrete slab panels, as well as reinforced concrete slab repair.

### Short description of the project

It studies the re-centering capability using new link typologies and the concrete slab influence.

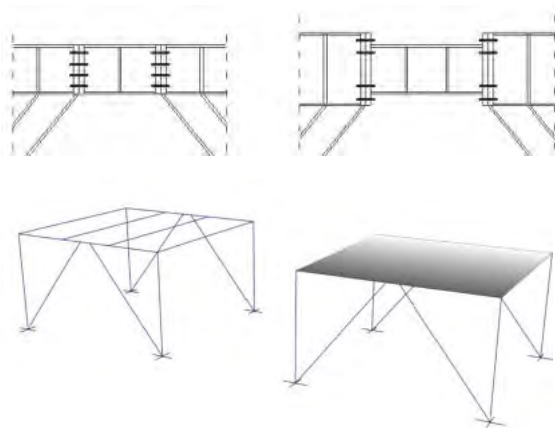

### Project implemented by

Politehnica University Timișoara (UPT) – Civil Engineering Faculty – Steel Structures and Structural Mechanics Department

### Implementation period

10.10.2018 – 09.10.2020

### Main activities

- Designing prototype structures with two height levels: medium rise (P+2E) and higher rise (P+5E), with differently connected links (flush/extended end-plate), extending the bolted links removal procedure and re-centering capability – done in 2018;

- Experimentally testing isolated links assemblies in two solutions: flush end-plate bolted link and extended end-plate bolted link, at natural scale (1:1), both of them with and without concrete slab above the link (8 tests) – proposed for 2019;
- Experimentally testing a 3D portal frame, with/without concrete, with damaged/repared slab (4 tests) – proposed for 2020;
- Calibrating numerical models post-test – proposed for 2019 and 2020;
- Seismic performance and behavior factors numerical assessment – proposed for 2020.

### Results

In 2018 – prototype structures design, re-centering capability validation and link removal procedure description.

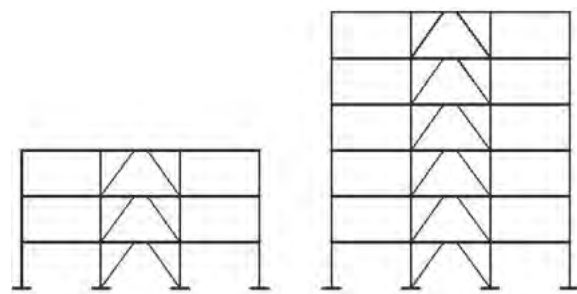

Proposed for 2019 and 2020:

- Design of experimental specimens;
- Material behavior curves;
- Links experimental results – describe local behavior;
- Frames experimental results – describe global behavior;
- Calibrated numerical models for links;
- Values of behavior factors for structures.

Obtained results will be presented in project deliverables and scientific papers at international conferences/journals.

## Applicability and transferability of the results

Increase the application potential of the system both at national and international levels: by improved connections (larger behavior factor obtained), improved knowledge on the effect of reinforced concrete slab and repair of the slab.

Solutions providing self-centering of the structure are technically demanded and require specialized knowledge, careful maintenance and high initial cost. Alternatively, a conventional design can be employed, but with the dissipative members realized to be removable allowing their replacement when damaged and reducing the repair costs.

## Financed through/by

Executive Agency for Higher Education, Research, Development and Innovation Funding (UEFISCDI)

## Research centre

Research Centre for Mechanics of Materials and Structural Safety - CEMSIG

## Research team

Assist. Mirela Adriana CHESOAN, PhD (project manager)  
Assoc. prof. Aurel STRATAN, PhD

## Contact information

Assist. Mirela Adriana CHESOAN, PhD  
Faculty of Civil Engineering  
Department of Steel Structures and Structural Mechanics,  
Ioan Curea Street No.1, 300224, Timișoara  
Phone: +40 (0) 256 403 925  
E-mail: [adriana.chesoan@upt.ro](mailto:adriana.chesoan@upt.ro)  
Web: [https://www.ct.upt.ro/centre/cemsig/arnis\\_en.htm](https://www.ct.upt.ro/centre/cemsig/arnis_en.htm)

## TESS - THERMO-ELECTRIC HYBRID SOLAR SYSTEM

### Goal of the project

The project relates to a solar thermal - electric hybrid, which produces hot water and electricity using thermoelectric modules.

### Short description of the project

The system is composed of thermoelectric modules, and solar concentrator photovoltaic cells that convert heat to increase efficiency and reduce losses by convection, using a vacuum chamber that allows the positioning unit conversion at any position and allows adjusting the amount wastewater heat transferred by replacing hexagonal mirror solar concentrator photovoltaic.

### Project implemented by

Department of Applied Electronics, Politehnica University Timișoara

### Implementation period

03.01.2017 – 31.03.2018

### Main activities

Mechanical system implementation  
Full working prototype  
Experimental validation  
Final stage

### Results

- 2 published Journal papers (Thomson Reuters WoS) IF>1.5, Q2 and Q3
- 2 ISI Journal papers (under review)
- 8 ISI conference papers
- 2 patents

### Applicability and transferability of the results

- Effective solution for domestic use
- Tool for complex modeling, simulation and measurement
- Real time flow control

### Financed through/by

Executive Agency for Higher Education, Research, Development and Innovation Funding (UEFISCDI), Bucharest, Romania.(UEFISCDI), PN-III-P2-2.1-PED-2016-0074, 499.700 RON (110.800 EUR)

### Research centre

Intelligent Electronic Systems, <http://www.ccesi.etc.upt.ro/>

### Research team

Aurel GONTEAN  
Roland SZABO  
Szilard BULARKA  
Alexandru SFIRAT

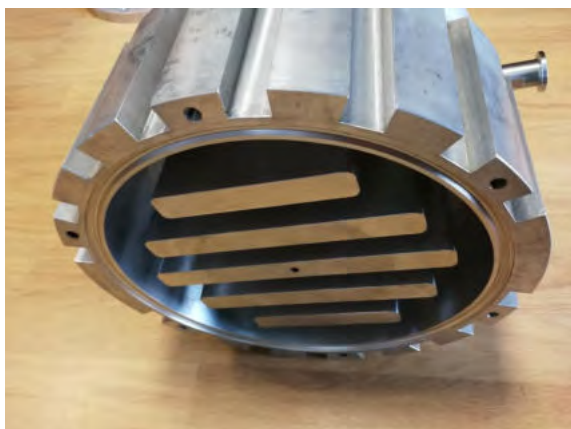

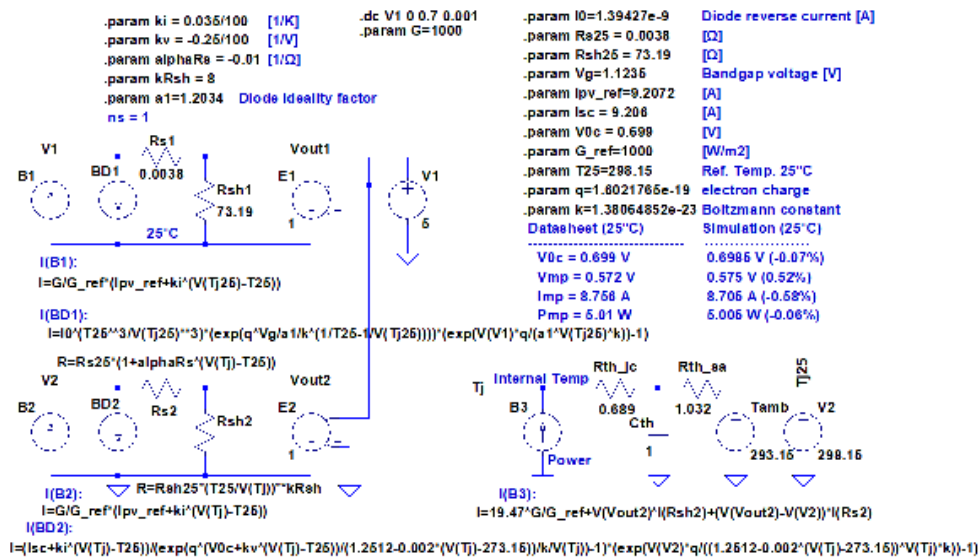

## Contact information

Prof. Aurel GONTEAN, PhD  
 Faculty of Electronics, Telecommunications and Information Technologies  
 Department of Applied Electronics  
 Address: Bd. Vasile Parvan 2, 300199, Timisoara  
 Phone: (+40) 256 403 333, Mobile: (+40) 745 121 383  
 E-mail: aurel.gontean@upt.ro,  
<https://sites.google.com/site/aurelgontean/home>  
<http://tess.upt.ro>

## DUAL STATOR WINDING INDUCTION GENERATOR SYSTEM FOR WIDE-VARIABLE SPEED WIND POWER APPLICATION (DSWIG)

### Goal of the project:

For wind power plants, the cage-type induction generator (IG), as a competent option, has many advantages for wind power applications, such as innate brushless construction, low maintenance demand, good overload protection ability, and so on. The most significant advantages of this machine lie in its ability to output good performance electric power at variable rotor speeds. To adapt the wide variation of wind speed and capture much more wind energy, the wind power system should have the variable-speed operation ability in a wide speed range.

### Short description of the project:

The subject of the bilateral project, which relates to a wind power system with a dual stator-winding induction generator.

### Project implemented by

Politehnica University Timisoara (UPT) - România  
Nanjing University of Aeronautics and Astronautics (NUAA) - China

### Implementation period:

02.07.2018-31.12.2019

### Main activities:

The basic priority of the collaboration is the development of a scientific project for participation in competitions announced by Horizon 2020 and other international programs. The work plan proposed is based on regular meetings of the members of both teams alternately in Romania and China; a) a first visit will be in China, by a team from Romania. On this occasion the Romanian members will meet all the team members from China, will visit research labs; b) the next meeting will take place in Romania, at Timișoara at the Faculty of Electrical and Power Engineering, at the Romanian Academy Branch Timișoara and at the Hunedoara Engineering Faculty. On this occasion contact will be established with all members of the project team from Romania, visits will be carried out to the research laboratories of the two faculties, and there will be group discussions between members of both teams according to scientific areas of joint research.

### Results:

The results for the Year 2018 are:

Between July 2 and December 31, 2018, was carried out on the topic of DSWIG Generator Design. At this stage, the Romanian team carried out the following activities: dimensioning of the experimental model, analytical design, optimal design, finite element validation, design of the electric drive system and the experimental test bench. Between August 26 and 30, 2018, a team (Deaconu Sorin Ioan, Topor Marcel and Hulea Dan Cornel) from the Politehnica University Timisoara (UPT), made a trip to Budapest where he attended the IEEE International Conference on Power Electronics and Motion Control (PEMC), where they met a team from the Nanjing University of Aeronautics and Astronautics, China, led by BU Feifei, project director from the Chinese team.



### Applicability and transferability of the results:

The results obtained through this project are of interest to the industry of the construction of electrical machinery, renewable energy converters, wind systems, hydro systems, and producers of autonomous generators for vehicles, boats, river and sea vessels, and aircrafts. Based on the project developed by the team in Romania, the Chinese team will realize the experimental model and its control system. Following experimental testing, parameters and features will be obtained, and based on them, a Chinese producer will be identified to introduce these systems into production.

### Financed through/by

Executive Agency for Higher Education Research, Development and Innovation Funding (UEFISCDI)

### Research Center

Intelligent Control of Energy Conversion and Storage

### Research team

The research team of UPT consists in coordinator, Associate professor Sorin Ioan DEACONU, PhD teachers (PhD's):

Ion BOLDEA,  
Nicolae MUNTEAN,  
Lucian Nicolae TUTELEA,  
Marcel TOPOR,  
Ana-Adela MOLDOVAN-POPA,  
and engineers and PhD students:  
Liviu-Dănuț VITAN,  
Adrian Daniel MARTIN and  
Dan HULEA.

### Contact information

Assoc. Prof. Sorin Ioan DEACONU, PhD  
Faculty of Hunedoara Engineering  
Department of Electrical Engineering and Industrial Informatics  
Address: Revoluției Str., No.5, Postal Code 331128, Hunedoara  
Phone: (+40) 254 207 529  
Mobile: (+40) 744 544 846  
E-mail: sorin.deaconu@fih.upt.ro  
Web: <http://www.fih.upt.ro/dswig/>



## PERFORMANT POWER TRAIN FOR HYBRID AND ELECTRIC VEHICLES WITH DUAL ROTOR SINGLE STATOR AXIAL SYNCHRONOUS MACHINE AND SINGLE INVERTER - HELSAX

### Goal of the project:

The project goal of bilateral cooperation between the UPT-TUIASI and UTM proposed, is of major scientific and practical importance in reducing pollution from vehicles classic using hybrid vehicles or electric drive systems performance, and aims to develop and enhance knowledge of joint research teams from Romania and Moldova, as well as enhance mobility of researchers, exchange of experience and mutual access to research infrastructure of medium and high scale, existing in the three universities.

The basic priority of the collaboration is to develop, during the implementation of the joint project, of a scientific project for participation in competitions announced by Horizon 2020 of the European Union and other international programs.

### Short description of the project:

It proposes an international original solution in which the two electrical machines (generator and motor) and static converters related are replaced by a single synchronous permanent magnet machine having axial air gap, a central stator with slots on both sides and two different windings supplied from a single PWM inverter having two output frequencies, and two independent rotors.

### Project implemented by

Politehnica University Timișoara (UPT),  
Technical University "Gheorghe Asachi" Iași (TUIASI) and  
Technical University of Moldova (UTM)

### Implementation period:

September 2016 – March 2018

### Main activities:

The aim is to exploit the potential of joint research of the two teams for creating a system of electric drives for hybrid vehicles and electrical overall dimensions and low weight; reduce carbon emissions from vehicles; have a static converter that is simple and inexpensive; broadcast transmission system using differential electric vehicles; control of the two rotors so that they can operate in the same mode or in different modes at the same rotational direction or in opposite directions at the same speed value at slightly different speeds or at much different speeds. Specific objectives: increasing electrification of the vehicle; reducing vehicle weight; increasing the speed of operation of the electrical machine rotors for reducing the size of the actuator; sizing model for which the design (impose conditions of power, size, weight); design model for the electric drive system and the stand of experimental tests; increasing efficiency

for the electric drive system; the practical design of the machine, inverter and battery accumulators; exhibition experimental test setup; implementation and testing of the various experimental control solutions; creating an intelligent system for managing production and electricity consumption per vehicle. Expected results: a much easier vehicle with an electric drive system; low inertia rotor at high speeds; a compact electric drive system with high torque and simple control; an inverter that manages various operation modes with different speeds equal to or in the same direction or in opposite directions of the two rotors.

### Results:

The work plan in 2016 was based on regular meetings of members of both teams alternately in Romania and Moldova. First visit was in Moldova, by a team from Romania. On this occasion the Romanian members met the team members from Moldova, visited research labs, they did contact with their scientific concerns. During this movement, a conference occurred, in order to launch the project in Chisinau, where teachers and students from the Technical University of Moldova and specialists in electrical engineering enterprises in Chisinau, Balti and Tiraspol were invited .

Then followed a visit by a team from UTM to Faculty of Electrical Engineering and Energetics in Timisoara and the Faculty of Engineering Hunedoara. On this occasion contact were established with all members of the project team from Romania, were visited research laboratories of the two faculties, and there was group discussions between members of both teams according to scientific areas of joint research. One conference was organized in order to launch the project in Timisoara, where teachers and students at the University Politehnica Timisoara and specialists of enterprises of Timisoara and Arad with automotive profile were invited. There was a travel team from Chisinau to visit industrial companies in the automotive industry in Hunedoara and Deva (Lisa Draexlmaier Hunedoara, Sews Deva).

## Applicability and transferability of the results:

The motors excited by permanent magnets in a variety of designs, gaining more ground in the competition with the DC classics, because of high technical and economic achievements, especially under current conditions, in association with improved electronic supply sources and assisted computer systems that are more and more competitive. Obtaining reasonable torque values for a wide range of variation of speed, drive systems through simple procedures, are no longer a difficulty that cannot be solved. Using motors excited by permanent magnets and brushless fractional number of slots per pole and phase engines in particular, as actuators in servo-drives for low power and area, has expanded compared to the classic DC due to the progress of power electronics and information technology, without which one can not conceive an elastic system containing modern drive controllable speeds in wide range. With integrated systems for the electric drive, having adequate topologies actuators as execution elements, through the use of more evolved control algorithms and integrating functionality at both hardware and software, may lead to dynamic and superior performances, more precise control of speed or position, high electromagnetic torque, higher energy efficiency and high accuracy while simultaneously reducing overall system cost consistently. The project results will contribute to community social objectives to combat climate change. The main contribution is to reduce emissions of CO<sub>2</sub> and emissions of greenhouse gases. The project proposes new technologies and contributes to sustainable economic development.

## Financed through/by

UEFISCDI

## Research Center

UPT members of the research team are also members of the University's two research centers: the Institute for Renewable Energy and Research Centre for the intelligent control of power conversion and storage.

## Research team

The research team consists of UPT coordinator Assoc. Prof. Sorin Ioan DEACONU, PhD, teachers (PhD's): Nicolae MUNTEAN, Lucian Nicolae TUTELEA, Liviu MIHON, Octavian CORNEA, Ciprian ȘORÂNDARU, Marcel TOPOR, engineers and PhD students: Loredana GHIORMEZ and Csaba GHEORGHIU.



Informbusiness Chișinău laboratory for experimental work.



Helsax project launch conference in Chisinau.



Helsax project launch conference in Hunedoara.

## Contact information

Associate Prof. Sorin Ioan DEACONU, PhD  
Faculty of Hunedoara Engineering  
Department of Electrical Engineering and Industrial Informatics  
Address: Revolutiei Str., No. 5,  
Postal Code 331128, Hunedoara  
Phone: (+40) 254 207529  
Mobile: (+40) 744 544846  
E-mail: sorin.deaconu@fih.upt.ro  
Web: www.fih.upt.ro

## INTELLIGENT SYSTEM FOR AUTOMATIC DIAGNOSIS OF THE CONTACT LINE OF ELECTRIC RAIL TRANSPORT

### Goal of the project:

The project provide an intelligent system for determining the actual state of the contact line (CL) and performing maintenance working on the basis of data generated by this system. To this end, a pantograph-draisine existing, used for maintenance, was be equipped with an automatic system for measuring the technical parameters of CL. An expert system analyzes measured data and provide two kinds of decisions: urgent intervention points, and predictions on future developments in the CL state.

### Short description of the project

Measurement of geometric parameters will be done with a video-camera and a laser distance sensor.

### Project implemented by

- Politehnica University Timișoara and S.C. Electrificare C.F.R. S.A. Bucharest

### Implementation period

30.09.2016-30.09.2018

### Main activities

- Study of measuring means of geometric parameters and specific dynamic regimes the contact line (CL), taking into account the its operation under the voltage of 27,5 kV;
- Designing the measurement and data acquisition system based on the constructive and functional characteristics of the pantograph-draisine;



- Implementation of the measurement and data acquisition system under laboratory conditions for functional analysis, tests, corrections;

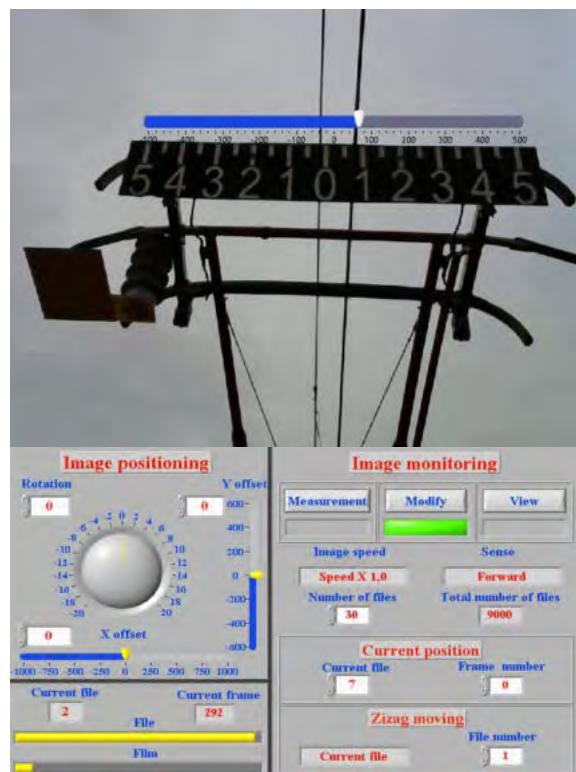

- Installing on the pantograph-draisine of the measurement and data acquisition system of the main parameters required for the CL diagnosis;

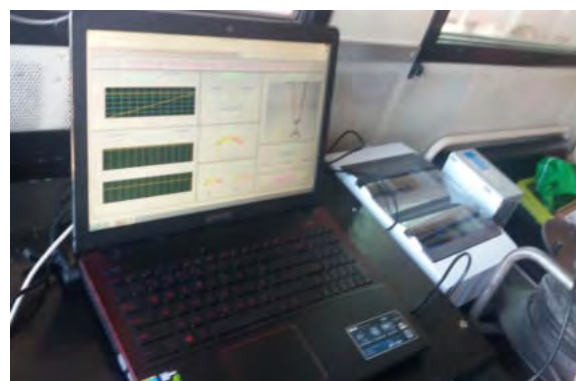



- Design and realization of an expert system for automatic diagnosis of the CL;



- Industrial testing of intelligent system for automated diagnosis of the CL;

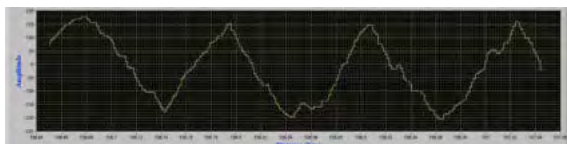

- Transferring the results to the economic agent.

## Results

- Industrial system for measurement and acquisition of data on rail mounted pantograph-draisine in the sector of CL Iliia;
- Expert system for automatic diagnosis of CL in railway electric transport;
- Intelligent system documentation for automatic diagnosis of CL from railway electric transport containing: technical documentation, measurement sets and result of measurement processing;
- 11 scientific articles published in the volumes of international conferences/journals.

## Applicability and transferability of the results

The system is designed to be mounted on any pantograph-draisine of the equipment maintenance sectors in the CL and performs measurements and primary data processing automatically daily at various draisine movement at works. Subsequently, the database is transferred and analyzed on a computing system at the headquarters of the sector for a technical analysis of the traveled path and the detection of critical areas.

The system was transferred to the beneficiary and was mounted on pantograph-draisine in the CL Iliia sector.

## Financed through/by

PNCDI III - Programme 2 - Subprogramme 2.1. Competitiveness by research, development and innovation  
Transfer of Knowledge to the Economic Agent "Bridge Grant" 2016

## Research Center

NU

## Research team

PROJECT LEADER:  
Stela RUSU-ANGHEL, Ph.D.,  
PROJECT MEMBERS:  
Manuela PĂNOIU, Ph.D.,  
Virgilius Caius PĂNOIU, Ph.D.,  
Sorin Ioan DEACONU, Ph.D.,  
Ionel MUSCALAGIU, Ph.D.,  
Raluca ROB, Ph.D.,  
Cristian Abrudean, Ph.D.,  
Ciprian LIHACIU

## Contact information

Stela RUSU-ANGHEL, PhD  
Faculty of Engineering Hunedoara/  
Department of Electrical Engineering and Industrial Informatics  
Address: Str.Revolutiei, No.5 Postal Code 331128, Hunedoara  
Phone: (+40) 254 207 540  
E-mail: stela.rusu-anghel@upt.ro

## THE RELATIONSHIP BETWEEN ENERGY INVESTMENTS, SHOCKS IN ENERGY PRICES AND THE MACROECONOMY IN THE EU COUNTRIES (EIP-MACRO)

### Goal of the project:

Energy prices record high fluctuations increasing market uncertainty. The central role of oil prices in influencing consumption, investments and macroeconomic policies requires special attention. In this context, the main goals of the project are: (i) to analyze the investment behavior and TFP of energy sector companies using firm-level data; (ii) to investigate the non-linear interactions between oil prices and the macroeconomy; (iii) to assess the environmental impact of energy policies, EU regulations and renewable energy consumption.

### Short description of the project:

The project aims to provide a deeper understanding of the energy and environmental economics issues, analyzing the interactions between energy prices and the macroeconomy.

### Project implemented by

Politehnica University Timișoara

### Implementation period:

02.05.2018 – 30.04.2020

### Main activities:

- a) Development of research on three directions:
  - determinants of investments and TFP of energy companies
  - macroeconomic impact of oil price shocks
  - environmental impact of energy policies.
- b) Manipulation of AMADEUS statistics for firm-level data and EIA statistics at macro-level
- c) Econometric analyses and generation of results
- d) Collaboration with international researchers
- e) Dissemination of results in conferences and high-ranked journals.
- f) Project management including the establishment of research tasks, identification of dissemination opportunities and research stages.

### Results:

- a) Interim report no. 1
- b) Publications
  - ISI journals papers:
    - Grecu, E., Aceleanu, M.I. and Albulescu, C.T., 2018. The economic, social and environmental impact of shale gas exploitation in Romania: A cost-benefit analysis, *Renewable and Sustainable Energy Reviews*, 93, 691-700. (Q1)
    - Albulescu, C.T. and Pépin, D. (2018). Monetary integration, money demand stability and the role of monetary overhang in forecasting inflation in CEE countries, *Journal of Economic Integration*, 33(4), 841-879.
  - BDI journals papers:
    - Albulescu, C.T., Tămășilă, M. and Vartolomei, M. (2018). Value added and productivity determinants in the water industry: Panel data evidence from the West region of Romania, *Scientific Bulletin of Politehnica University of Timisoara, Transaction on Engineering and Management*, 4(1), 8-13
- c) Conference participations:
  - 5th Annual Scientific Conference of Romanian Academic Economists from Abroad (ERMAS 2018)
  - 20th INFER Annual Conference
  - Conference on Resilience of emerging market economies to global financial conditions
- d) Research stages:
  - Claudiu Albulescu (Université de Poitiers, CRIEF)

## Applicability and transferability of the results:

The results of the project have both a micro- and a macro-level applicability. In the first case, the strategic management of companies activating in the energy field will benefit from a deeper understanding of elements influencing the level of investment in the industry. In the second case, national and international regulators and policy makers receive information about the impact of shocks in energy prices on inflation and exchange rate, but also about the effectiveness of environmental regulation and the role of renewable sources in reducing CO2 emissions at EU level.

## Financed through/by

Executive Unit for Financing Higher Education, Research, Development and Innovation - UEFISCDI

## Research Center

Research Center in Engineering and Management

## Research team

Prof. Claudiu ALBULESCU, PhD (Principal Investigator)  
Assoc. Prof. Alin ARTENE, PhD  
Assoc. Prof. Caius LUMINOSU, PhD  
Assist. Prof. Șerban MICLEA, PhD  
Maria BOATCĂ-BARABAȘ, PhD student  
Roxana SÎRBU, PhD student

## Contact information

Prof. Claudiu ALBULESCU, PhD  
Faculty of Management in Production and Transportation,  
Department of Management  
Address: Remus Street, no. 14, 300191, Timișoara  
Phone: (+40) 256 404 035  
Mobile: (+40) 743 089 759  
E-mail: claudiu.albulescu@upt.ro  
Web: <https://sites.google.com/site/eipmacrote2016/home>

## INCREASING THE INSTITUTIONAL PERFORMANCE OF THE POLITEHNICA UNIVERSITY TIMIȘOARA BY STRENGTHENING THE R & D AND TECHNOLOGICAL TRANSFER CAPACITY IN THE FIELD OF “ENERGY, ENVIRONMENT AND CLIMATE CHANGE”

### Goal of the project

The overall objective of the PERFORM-TECH-UPT project is to increase the institutional performance of the Politehnica University Timișoara (UPT), by developing the R & D capacity of the Research Institute for Renewable Energy, a structure of UPT, by expanding and consolidating its activities in the field of intelligent specialization Energy, Environment and Climate Change, to serve the innovation requirements of economic operators from Romania West Development Region, respectively by intensifying the collaboration and visibility at national and international level.

### Short description of the project

The PERFORM-TECH-UTP project is dedicated to UPT's institutional development by supporting human resources, developing R & D infrastructure, promoting and increasing UPT's international visibility.

### Project implemented by

Politehnica University Timișoara

### Implementation period

October 16th, 2018 - December 10th, 2020 (26 months)

### Main activities

- Project management and coordination
- Acquisition of significant R&D equipment and services
- Financial support for attending prestigious international conferences
- Stimulate the publication of articles in WOS indexed journal, located in the Q1
- Stimulation of the doctoral research activity of the last year of internship for the successful completion of the experimental part of the thesis
- Identifying funding opportunities for research and the development of successful applications
- Development of a portfolio of new products / technologies / methods / systems / services or significantly improved
- Selection of postdoctoral researchers in the field of the project
- Integration and testing of purchased equipment within research centers / laboratories
- Creating the site [www.research.at.upt.ro](http://www.research.at.upt.ro)



### Results

- Elaboration of common multidisciplinary research directions, harmonized with the strategic plan of UPT
- Improving RDI infrastructure
- Testing of RDI infrastructure equipment
- Developing articles indexed in ISI journals
- Increasing the international visibility of UPT by participating in prestigious international conferences
- Supporting young researchers in areas of intelligent specialization

### Financed through/by

Ministry of Education, “Program 1 - Development of the National Research and Development System, Subprogram 1.2 - Institutional Performance”, National Plan for Research, Development and Innovation for the period 2015-2020 (PNCDI III), Institutional Development Project - CD Excellence Funding Project.

## Research centre

1. Research Institute for Renewable Energy
2. Research Centre for Smart Energy Conversion and Storage
3. Research Centre for Mechanics of Materials and Structural Safety
4. Research Centre for Processing and Characterization of Advanced Materials
5. "Ștefan Nădăsan" Research Laboratory for Strength, Integrity and Durability of materials, structures and conductors.

## Research team

Assoc. Prof. Liviu CĂDARIU-BRĂILOIU, PhD  
Prof. Eng Viorel-Aurel ȘERBAN, PhD  
Prof. Eng. Viorel UNGUREANU, PhD  
Prof. Eng. Nicolae MUNTEAN, PhD  
Prof. Eng. Liviu MARȘAVINA, PhD  
Prof. Eng. Petru NEGREA, PhD  
Assoc. Prof. Eng Bogdan. RADU, PhD

## Contact information

Assoc. Prof. Liviu CĂDARIU-BRĂILOIU, PhD  
Department of Mathematics  
Address: Piața Victoriei, No. 2, Postal Code 30006, Timișoara  
Phone: (+40) 256 403100  
Mobile: (+40) 725 890983  
E-mail: liviu.cadariu-brailoiu@upt.ro  
Web: <http://www.performtech.upt.ro/>



## RANSFER OF KNOWLEDGE TO INCREASE THE OPERATING TIME OF THE STORM PUMPS FOR THE WASTEWATER SYSTEMS - "TANAGRA"

### Goal of the project:

The storm pump blades were catastrophically destroyed due to clogging impeller. The fastening bolts of the blade broke fragile due to increased torque to the pump shaft. The project provides solutions to increase the operation time of the storm pumps. The solutions of the project cover three areas: (1) the hydrodynamic point of view to reduce the risk of clogging the impeller by analyzing the flow into the suction elbow geometry; (2) the mechanical point of view to increase the mechanical strength of the solution on fixing the impeller blades on pump hub; (3) an emergency shutdown procedure is targeted when the pump impeller is clogged with testing a technique of the impeller self-cleaning.

### Short description of the project:

A strategy of urban sewage centralized management is implemented in Timișoara city. All wastewater is collected and conveyed to a central location for treatment or disposal. In urban area, storm water is considered in wastewater management. Seven storm pumps are installed in the wastewater treatment plant to protect it against floods. Several catastrophic events have occurred at the storm pumps taking them out of service after short operation period. The catastrophic events were investigated and several solutions have been proposed to increase the operation time of the storm pumps installed in water treatment plant.

### Project implemented by

- Politehnica University Timișoara (UPT) together with AQUATIM Timișoara

### Implementation period:

September 2016 – November 2018

### Main activities:

The main activities were focused on: (1) investigation and analysis the technical solutions associated to the storm pumps available in situ; (2) numerical investigation of the flow into the pump; (3) experimental investigation of the waste and debris collected from wastewater; (4) analysis of the material and mechanical solution implemented in situ; (5) experimental investigations performed in situ to measure the electrical parameters of the pump; (6) assessment of the technical solutions implemented in situ. Also, several undergraduates and master students from UPT visited the sewage treatment plant understanding the new challenges faced by communities and authorities.

### Results:

Micota D., Gălățanu S.V., Marșavina L. and Muntean S. (2018) *Evaluation of the mechanical properties and failure mechanism of fibres formed in municipal wastewater systems*, 7th Int. Conf. on Advanced Materials and Structures (AMS2018), 28–31 March 2018, Timișoara, Romania.

Hedeș A., Svoboda M., Anton L.E., Muntean S. and Vitan D., (2018) *In situ measurements on the axial pumps motors of a wastewater station*, 18th Int. Conf. on Environment and Electrical Engineering, 12–15 June 2018, Palermo, Italy.

Gălățanu S.V., Muntean S., Marșavina L., Micota D. and Drăghici I. (2018) *Integrity Analysis of the Rainwater Pump Impeller*, 5th Int. Conf. of Engineering Against Failure (ICEAF V), 20–22 June 2018, Chios, Greece.

Muntean S., Bosioc A.I., Marșavina L., Gălățanu S.V., Drăghici I. and Anton L. E. (2018) *Failure analysis of the rainwater axial pumps installed in a wastewater pumping station*, 29th IAHR Symposium on Hydraulic Machinery and Systems (IAHR2018), 16–21 September 2018, Kyoto, Japan.

Bosioc A.I., Moș D., Draghici I., Muntean S. and Anton L.E. (2018) *Experimental Analysis of a Pump Equipped with an Axial Rotor with Variable Speed*, 29th IAHR Symposium on Hydraulic Machinery and Systems (IAHR2018), 16–21 September 2018, Kyoto, Japan.

Muntean S., Marșavina L., Hedeș A., Anton L.E. and Vlaicu I. (2018) *In situ investigations and failure analysis of the rainwater pumps from a wastewater treatment plant*, 20th Int. Conf. on Hydropower Plants, 14–16 November 2018, Vienna, Austria.

Ognean D., Moș D.C. and Muntean S. (2018) *Technical solution to increase capacity of the centrifugal pumps operated in the protection system against flooding due to climate change*, 20th Int. Conf. on Hydropower Plants, 14–16 November 2018, Vienna, Austria.

Gălățanu S.V., Muntean S., Marșavina L., Ailinei I., and Micota D. (2019) *Rainwater propeller pumps structural integrity*, International Journal of Structural Integrity (accepted).

## Applicability and transferability of the results:

Two technical solutions resulting from the research in the project were implemented in situ. First, the suction elbow installed to each pump inlet was removed in order to diminish the impeller clogging. Second, a new softstarter was installed to detect the clogging level of the pump impeller. A self-cleaning procedure is applied if the threshold clogging level is reached. Also, a mechanical solution to increase the mechanical strength of the solution on fixing the impeller blades on pump hub is proposed. However, this solution would be implemented in situ after the performances of the first two technical solutions already implemented are assessed.

## Financed through/by

Executive Unit for Financing Higher Education, Research, Development and Innovation (UEFISCDI) / Ministry of Research and Innovation

## Research Center

Research Center for Engineering of Systems with Complex Fluids, UPT

## Research team

Prof. Liviu Eugen ANTON, PhD, PI  
Prof. Liviu MARȘAVINA, PhD  
Sebastian MUNTEAN, PhD, SR  
Prof. Alexandru HEDEȘ, PhD  
Assist. Prof. Alin Ilie BOSIOC, PhD  
Assist. Prof. Sergiu GĂLĂȚANU, PhD  
Assist. Prof. Marcus SVOBODA, PhD  
Mariana TODIRUȚĂ, Researcher  
Liviu Dănuț VITAN, Master student  
Dan Ionel MICOTA, Master student  
Raul SZAKAL, Master student  
Denis OGNEAN, Master student

## Contact information

Prof. Liviu Eugen ANTON, PhD  
Faculty of Mechanical Engineering  
Department of Mechanical Machines, Equipment and Transportation  
Research Center for Engineering of Systems with Complex Fluids,  
Bv. Mihai Viteazu, No.1 Ro-300223, Timisoara  
Phone: (+40) 256 403692  
E-mail: liviu.anton@upt.ro  
Web: <http://mh.mec.upt.ro/tanagra/>

## INCREASING COMPETITIVENESS OF COLTERM BY OPTIMIZING VARIABLE SPEED CONTROL TECHNOLOGY OF LARGE POWER CENTRIFUGAL PUMPS FOR HEATING

### Goal of the project

The objective of this project is to integrate the new modern assemblies pump–electric motor–converter with variable speed control technology in the transport network of the thermal energy from Timișoara and the efficient operation of the entire transport network of the thermal energy.

### Short description of the project

The objectives of this project are the integration of the two modern assemblies in the transport network of the thermal energy from the city of Timișoara together with the efficient operation of the entire heating network. To achieve these objectives an experimental investigation will be carried out for the designated pumps from the transport system of the thermal energy from the two CET in order to obtain characteristic curves of operation.

### Project implemented by:

The project is implemented by a team from the Politehnica University Timișoara.

### Implementation period

30/09/2016 – 30/09/2018

### Main activities

There are three main activities.

The first one is to determine a protocol for experimental investigation of centrifugal pumps and to apply it on a couple of pumps from the Laboratory of Hydraulic Machines.

The second one is to investigate the pumps from CET Centru and establish the best operating pattern for these pumps.

The third one is to investigate the pumps from CET Sud and establish the best operating pattern for these pumps.

### Results

The estimated results of this project are the operating patterns of the centrifugal pumps from CET Centru and CET Sud and the best efficient operating pattern of these pumps. Until now, the pumps from CET Centru were investigated and the results are presented in the next three figures. In the first figure, we have the operating curves of the four centrifugal pumps from CET Centre. In the second figure, we have the best operating pattern for these four pumps.

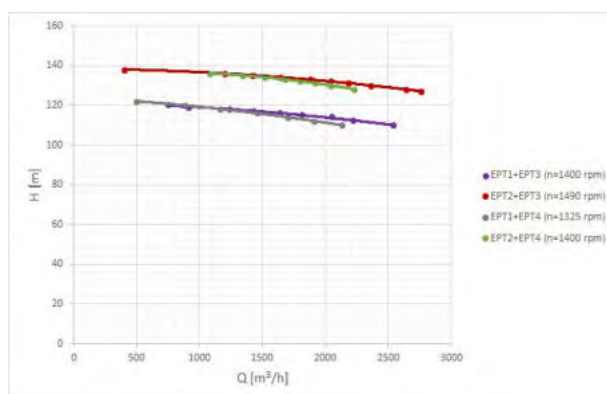
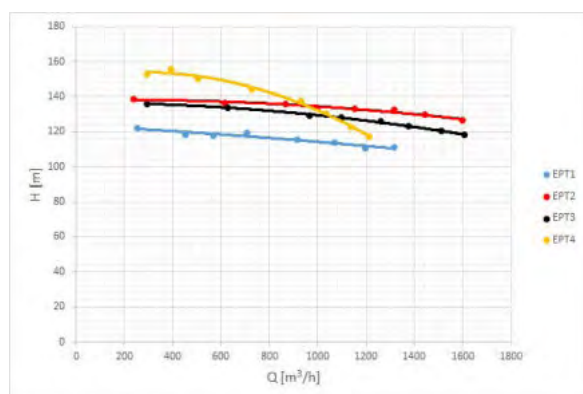

## Applicability and transferability of the results:

The best operating patterns of the centrifugal pumps from CET Centru and CET Sud will help Colterm to operate these pump at best efficiency in order to supply the necessary domestic hot water and thermal energy for the citizens of Timisoara. By doing this, Colterm will optimize the cost with electric energy.

## Financed through/by

CNCS – UEFISCDI, project number 69BG/2016/, project code PN-III-P2-2.1-BG-2016-0190

## Research Center

Research Centre for Complex Fluid Systems Engineering

## Research team

Assoc. Prof. Adrian STUPARU, PhD,  
Prof. Alexandru BAYA, PhD,  
Prof. Liviu ANTON, PhD,  
Asist. Prof. Alin BOSIOC, PhD,  
Eng. Mariana TODIRUȚĂ,  
Eng. Daniel MOȘ

## Contact information

Assoc. Prof. Adrian STUPARU, PhD  
Faculty of Mechanical Engineering  
Department of Mechanical Machines, Equipment and Transportation  
Address: Bvd. Mihai Viteazu, No. 1, 300222, Timișoara  
Mobile: 0744 642 076  
E-mail: [adrian.stuparu@upt.ro](mailto:adrian.stuparu@upt.ro)  
Web: <http://mh.mec.upt.ro/opexpc>

## INOVATIVE METHOD FOR LANDFILLING OF MUNICIPAL SOLID WASTE INCINERATION RESIDUES BY STABILIZATION/SOLIDIFICATION INTO COAL FLY ASH ROCK MATRIX RESULTED FROM DENSE SLURRY TECHNOLOGY

### Goal of the project

The project goal is treatment of MSWI residues by stabilization/solidification by means of using a binder matrix. The aim of this process is to create new compounds in a stabilized form that encompassing the harmful elements, which are non-hazardous or less hazardous than the raw (initial) material.

Project includes a series of experiments for embedding the MSWI residues into the coal fly ash rock matrix with the support of the preview research results. There will be done a small scale landfill disposal, in order to investigate the leaching behavior on environmental conditions for tracking the pollutants concentrations migration into environment.

### Short description of the project

The project concept is based on using fly ash and desulphurization products related to coal incineration as a binder material to stabilize through solidification process the pollutants (heavy metals mostly) contained in MSWI residues.

### Project implemented by

Politehnica University Timișoara

### Implementation period

01.05.2018 - 30.04.2020

### Main activities

The main activity of the project is to assess the discharge behavior of the experimental landfill disposal exposed into environmental conditions.

In this demand the following activity were foreseen:

- Construction of the experimental demonstrator.
- Evaluate the waste characteristics.
- Construction of the experimental landfill disposal according to the proposed technology.
- Leaching and percolation sampling.
- Lab analyses of experimental samples. Data recording.
- Processing and analyses of the experimental data.
- Interpretation of experimental data.
- Model the environmental behavior of the waste.
- Validate the model by calibration with the results from laboratory tests and field experiments and by comparing it to natural analogues.

### Results

**Stage I (2018) – Up-grading the existing lab demonstrator. Technical design. Purchasing of equipment.**

- 1.1 Preparation of design documents.
- 1.2 Designing installations for upgrading the experimental demonstrator in accordance with the proposed technology.
- 1.3 Elaboration of technical datasheets for equipment purchasing.
- 1.4 Launch of the public procurement procedure in accordance with the legislation in force.
- 1.5 Reception of purchased equipment. Equipment payment.

**Stage II (2019) – Construction of experimental demonstrator (upgrade). First run. Testing. Lab analyses**

- 2.1 Integration on technological assembly

## Applicability and transferability of the results

The solidification/stabilization method of different types of toxic residues consists of using a binder matrix, which is non-pollutant for the environment with the aim to encapsulate the harmful chemical compounds.

In this regard most of the applied technologies are using cement based binder matrix material which is an expensive material in comparison with coal fly ash and associated flue gas desulphurization (FGD) by-products related to coal power plants.

In fact the coal fly ash and FGD by-products are residues that end into open landfill disposal, which means that are costs free.

More than that is well known that cement factory worldwide are using coal fly ash as material basis for different types of cements, for their cementitious properties given by the pozzolanic compounds like silica (SiO<sub>2</sub>), alumina (Al<sub>2</sub>O<sub>3</sub>), and iron oxide (Fe<sub>2</sub>O<sub>3</sub>) that exceeds over 80% of the fly ash composition.

The new proposed technology based on using fly ash and desulphurization by-products related to coal incineration as a binder material according to solidification/stabilization method, will eliminate the costs with the cement, which could bring considerable economical savings.

From environmental point of view the incineration residues (fly ash and FGD by-products) related to coal incineration can be used as binder material according to the proposed concept of solidification/stabilization method, with the aim to prevent ground water pollution by leaching phenomenon developed on open landfill disposals by dense slurry technology.

## Financed through/by

Executive Agency for Higher Education, Research, Development and Innovation Funding – UEFISCDI /  
PN-III-P1-1.1-PD-2016-1093

## Research centre

Research Institute for Renewable Energies – ICER

## Research team

### Research contract director /Coordinator:

Eng. Mihail Reinhold WÄCHTER, PhD

### Mentor:

Prof. Daniel DAN, PhD

## Contact information

Eng. Mihail Reinhold WÄCHTER, PhD  
Faculty of Mechanical Engineering  
Address: Blvd. Mihail Viteazu, No.1, 300222, Timisoara  
Mobile: (+40) 742 171 963  
E-mail: wachter\_reinhold@yahoo.com  
Web: [https://www.ct.upt.ro/centre/reco/wir-stab-01\\_ro.htm](https://www.ct.upt.ro/centre/reco/wir-stab-01_ro.htm)

## AFFORDABLE AUTONOMOUS UNDERWATER VEHICLE (AUV) FOR SEARCH, INSPECTION AND MAINTENANCE OPERATIONS IN TURBID UNDERWATER

### Goal of the project:

Developing an underwater enhancing technique that can work in real-time for affordable Autonomous Underwater Vehicle (AUV)

### Short description of the project:

Autonomous Underwater Vehicles (AUVs) are devices able to follow a predefined route or is computing and adjusting the route as a result of sensor measurements. They were developed and used successfully on various applications; such as oceanographic surveys, bathymetric measurements, underwater maintenance and inspections activities (e.g. of the hydroelectric dams, bridges, sea wind turbines and oil sea platforms structure). Taking advantage of the latest advances in hardware and software, an ever-increasing number of underwater studies rely on AUVs that offer increased operational range and reduce potential hazards compared to classical methods involving divers or manned submersibles.

However, the existing AUVs performances are currently very limited due to the poor underwater visibility. In general the existing restoration techniques are too computationally expensive for AUVs. This project proposes a radically novel paradigm that provides the basis for more direct, interactive and efficient underwater studies, while reducing the associated costs. The technologies developed in the context of this project will allow the scientists to directly study, in an immersive way and in real-time, the environment surveyed by the AUVs, while allowing remotely interacting with the vehicle in a natural and intuitive manner.

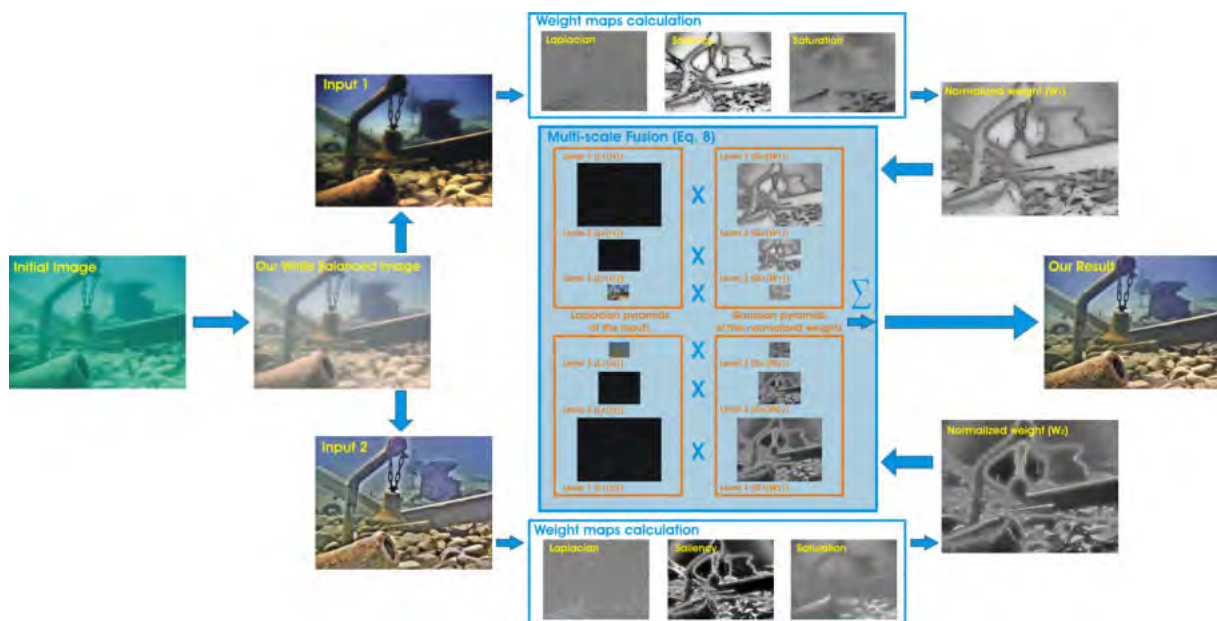

Figure 1: Overview of the proposed method.

Project implemented by

Politehnica University Timișoara, Romania

Implementation period:

January 2017- June 2018

## Main activities:

The main activities of the project:

- identification of specific requirements of underwater imaging technique to be implemented on a specific hardware platform;
- design of an exploration path for specific functionalities;
- designing and recording of specific underwater image scenarios;
- implementation of the underwater imaging technique;
- optimize and integrate the underwater enhancing technique;
- publish the results;

## Results:

- Developing an effective underwater enhancing technique
- 2 WOS/ISI papers and 1 BDI paper
- 1 ISI journal (IEEE Transactions on Image Processing, Q1, impact factor 4.8)

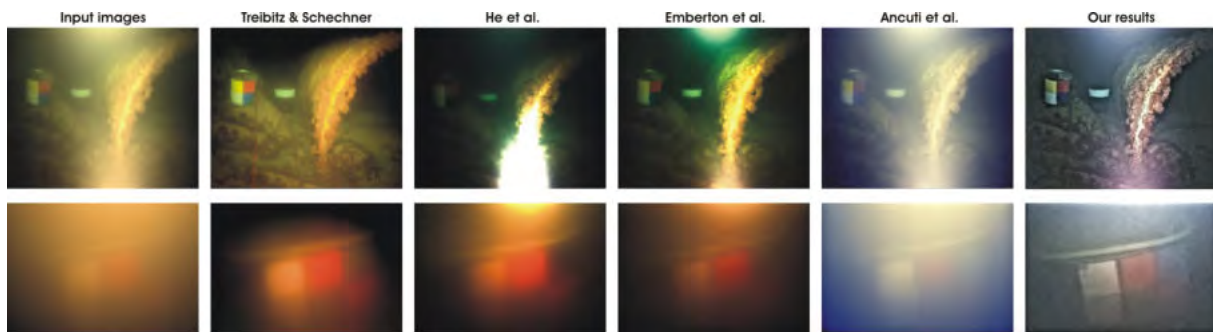

Figure 2: Underwater dehazing of extreme scenes characterized by non-uniform illumination conditions. Our method performs better than earlier approaches of Treibitz and Schechner, He et al., Emberton et al. and Ancuti et al

## Applicability and transferability of the results:

The outcome of this project may be applied in the field of underwater imaging and in the AUV's industry.

## Financed through/by

Executive Agency for Higher Education, Research, Development and Innovation Funding (UEFISCDI), Bucharest, Romania

## Research Center

Research Center of Intelligent Systems

## Research team

Assoc. prof. Cosmin ANCUTI, PhD  
 Assoc. prof. Horia BALTA, PhD  
 Eng. Codruta ANCUTI, PhD  
 Arpad KIS, PhD Student

## Contact information

Assoc. prof. eng. Cosmin ANCUTI, PhD  
 Faculty of Electronics, Telecommunications and Information Technologies  
 Department of Measurements and Optical Electronics  
 Address: 2 Vasile Parvan Blvd., room B312, 300223, Timișoara,  
 Email: cosmin.ancuti@upt.ro  
 Tel: (+40)-0256-403363, Fax: (+40)-0256-403295



## RESEARCH CONCERNING CHARACTERIZATION AND IMPROVEMENT OF THE ELECTROMAGNETIC ENVIRONMENT IN MODERN CARS

### Goal of the project

- Assessment of the electromagnetic environment in modern vehicles: technical and legal aspects;
- Assessment and analysis of measuring and testing methods and of equipment involved in Automotive EMC;
- Implementation of novel test and measurement methods in Automotive EMC and improvement of the testing repeatability
- Applications of metamaterials to Automotive EMC.

### Short description of the project

This project is component of the complex project *Hybrid Platform for Communication in Visible Light and Augmented Reality for the Development of Intelligent Systems for Assistance and Active Security of Vehicles*, 21PCCDI / 2018.

### Project implemented by

Politehnica University Timișoara,  
Faculty of Electronics, Communications and Information Technology,  
Department of Measurements and Optical Electronics

### Implementation period

18.05.2018 - 16.11.2020

### Main activities

1. Characterization of the electromagnetic environment in vehicles:
  - Near field and far field measurement;
  - Spectral occupancy measurement.
2. Improvement of repeatability of Automotive MC tests
  - Assessment of devices and equipment involved;
  - Interlaboratory testing and comparisons
  - Far-field prediction from near-field measurements data;
  - Prediction of far-field radiation from current measurement.
3. Methods of reduction of conducted and radiated emissions;
  - Resonance analysis of systems that fail EMC tests;
  - Applications of metamaterials: filtering, suppressing of cavity oscillations, screening with frequency selective surfaces.

### Results

2018

- Documentation concerning assessment of electromagnetic field in modern cars;
- Documentation concerning foreseen electromagnetic environment in electric cars and related EMC aspects;
- Documentation concerning applications of metamaterials in the Automotive EMC field;
- 10 published papers on:
  - Emissions and immunity testing in Automotive EMC (Fig. 1);
  - Interlaboratory comparison of radiated emissions;
  - ALSE chamber validation (Fig. 2);
  - Stripline measurements in Automotive EMC;
  - Near field measurements and applications to emission reduction (Fig. 3);
  - Frequency selective surfaces;
  - Spectrum occupancy measurement in the HF domain;
  - Application of Raspberry Pi.

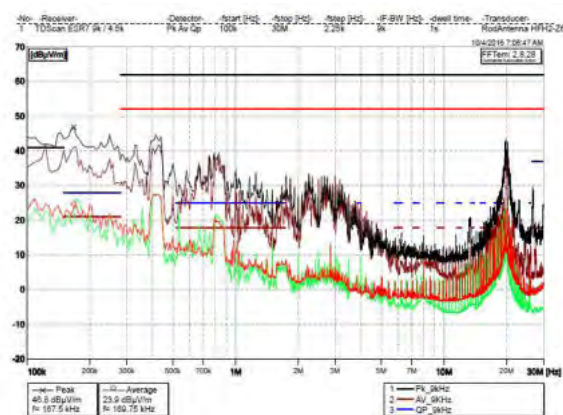

Fig. 1. Results of radiated emission tests on the same DUT using a monopole antenna in two different semi-anechoic chambers.



Fig. 2. Testing setup for chamber validation with biconic antenna

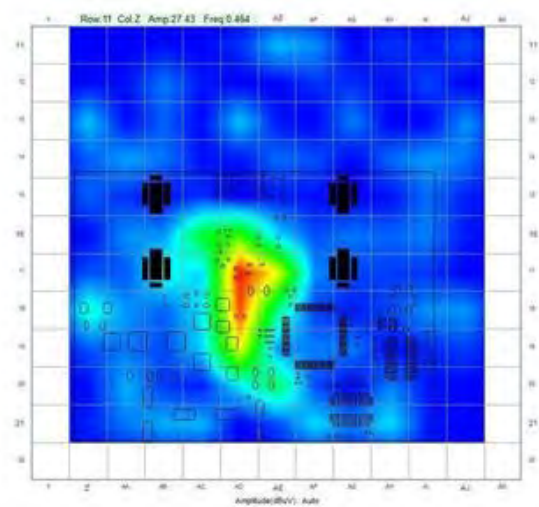

Fig. 3. Near-field scanning

## Applicability and transferability of the results

Results obtained in this research might be useful to:

- EMC laboratories, mainly related to Automotive industry;
- EMC professionals;
- EMC research community;
- EMC standards elaboration;
- Legal authorities that regulate spectrum occupancy;
- Professionals working in Automotive design.

## Financed through/by

Executive Unit for Financing Higher Education, Research, Development and Innovation - UEFISCDI

## Research centre

ICER - Research Institute for Renewable Energy

## Research team

Aldo de SABATA  
Cornel BALINT  
Septimiu MISCHIE  
Cora IFTODE  
Andrei SILAGHI

## Contact information

Prof. Aldo DE SABATA, PhD  
Faculty of Electronics, Communications and Information Technology/  
Department of Measurements and Optical Electronics  
Address: Bd. V. Pârvan, No. 2, Postal Code 300223, Timisoara  
Phone: (+40) 256 403370  
E-mail: aldo.de-sabata@upt.ro  
Web: <http://www.meo.etc.upt.ro/>

## TRANSFER OF KNOWLEDGE FOR FATIGUE STRENGTH EVALUATION OF STEERING WHEELS SKELETON

### Goal of the project

- Interconnection of the expertise of the project team from Politehnica University Timișoara with the quality assurance requirements of TRW Company for the steering wheels.
- Transfer of knowledge regarding the static and dynamic characterization of Magnesium alloys.
- Intensification of the cooperation between Politehnica University Timișoara and TRW Company for understanding of mechanical behavior and for the implementation of a methodology to assess the durability of steering wheel skeletons.

### Short description of the project

The project propose a transfer of knowledge from the experts from Politehnica University Timișoara in order to implement the methodology to determine the fatigue strength of steering wheel skeleton.

### Project implemented by:

Politehnica University Timișoara and  
TRW AUTOMOTIVE SAFETY SYSTEMS SRL (Economic partner)

### Implementation period

30/09/2016-29/09/2018

### Main activities

- Interconnection of the expertise of the project team from Politehnica University Timișoara with the quality assurance requirements of TRW Company for the steering wheels.
- Mechanical characterization and determination of static and dynamic properties of Magnesium alloys used for steering wheels.
- Elaboration of material models for Magnesium alloy AM50. Numerical estimation of durability of steering wheel skeletons.
- Practical training of master students from Politehnica University Timișoara on modern equipment of TRW company.

### Results

The TRW company will implement a methodology to evaluate the fatigue strength for the steering wheels skeleton made of Magnesium alloys and will be able to perform in-house tests at the Timișoara branch.

After the project implementation the TRW company will receive a methodology to assess the static and dynamic characteristics of Magnesium alloys. Also, will be developed the methodology to assess the fatigue strength of steering wheels skeletons. Very important results are represented by fatigue curves for Magnesium alloy, which could be useful in the design stage to perform numerical durability studies.

Participation at two international conferences ARTENS - Sibiu 2016 and ICSID - Dubrovnik 2016. Publication of the paper FATIGUE ANALYSIS OF MAGNESIUM ALLOYS COMPONENTS FOR CAR INDUSTRY, Authors L. Marsavina, L. Rusu, D. Serban, R. Negru, A. Cernescu, ACTA UIVERSITATIS CIBINIENSIS – TECHNICAL SERIES Vol. LXIX 2017, p. 47-51

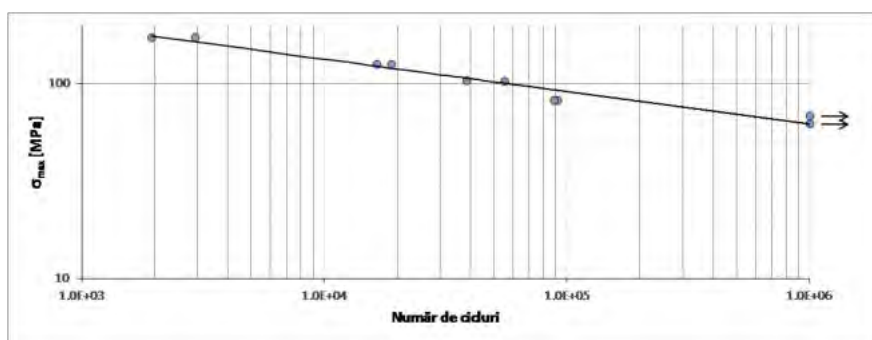

Fatigue curve on tensile loading for AM50 Magnesium alloy

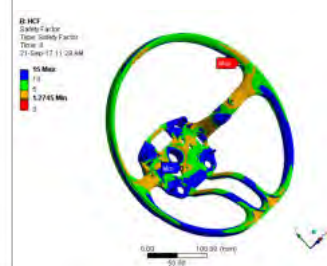

Safety factor under fatigue loading

## Applicability and transferability of the results:

The TRW company will implement a methodology to evaluate the fatigue strength for the steering wheels skeleton made of Magnesium alloys and will be able to perform in-house tests at the Timișoara branch. After the project implementation the TRW company will receive a methodology to assess the static and dynamic characteristics of Magnesium alloys. Also, will be developed the methodology to assess the fatigue strength of steering wheels skeletons. Very important results are represented by fatigue curves for Magnesium alloy, which could be useful in the design stage to perform numerical durability studies.

## Financed through/by

Bridge Grant PN-III-P2-2.1-BG-2016-0060, Contract 89BG/2016 89 by Romanian Ministry of Research trough UEFISCDI

## Research Center

ICER

## Research team

Prof. Eng. Liviu MARSAVINA, PhD – Project Manager  
Eng. Radu NEGRU, PhD – Researcher,  
Eng. Emanoil LINUL, PhD – Researcher,  
Eng. Lucian RUSU, PhD – Researcher,  
Eng. Dan A. SERBAN, PhD – Researcher,  
Eng. Sergiu GĂLĂȚANU, PhD – Researcher,  
Eng. Liviu PÎRVULESCU, PhD – Researcher,  
Eng. Alecsandru FALK – PhD student,  
Mat. Raluca PEPELAN – PhD student,  
Eng. Tamasz KRAUSZ – Master student

## Contact information

Prof. Liviu MARSAVINA, PhD  
Faculty of Mechanical Engineering  
Department of Mechanics and Strength of Materials  
Address: Blvd. M. Viteazu, No. 1, 300222 Timisoara  
Phone: (+40) 256 403 577, Mobile:(+40) 726 397 635  
E-mail: liviu.marsavina@upt.ro  
Web: <http://dev.mioritix-media.ro/2423/>

## TRANSFER OF KNOWLEDGE FOR DASHBOARD AND HEAD-UP DISPLAY OPTIMIZATION THROUGH TESTING AND MODELLING OF ADVANCED MATERIALS

### Goal of the project

The goal of the project is the determination of strain rate and temperature variation in mechanical properties of several advanced materials used in vehicle instrument clusters and Head-Up displays. With the gathered experimental data, non-linear material models are to be developed for the use in finite element analysis of various components during the product design stage.

### Short description of the project

This project deals with the mechanical characterization and numerical simulations of advanced materials used in the automotive industry

### Project implemented by:

This project is implemented by Politehnica University Timișoara with the support of Continental Automotive Romania.

### Implementation period

01/10/2016 – 31/03/2018

### Main activities

01. Determination of the mechanical and thermal properties of the investigated materials
  - Static tests (determination of the influence of strain rate and temperature)
  - Fatigue tests
  - DMA tests
02. Development and evaluation of constitutive models used in simulations
  - Development of constitutive models based on the gathered experimental data
  - Evaluation of the developed material models through experiment replication
03. Implementation of the constitutive models in product simulations
  - Analysis of simulation results and comparison with experimental data
  - Identification of optimal models from an accuracy and simulation time standpoint
04. Development of procedures for facilitating the introduction of new materials
  - Establishment of a test benchmarks
  - Proposal of easy-to-calibrate material models for simulating new materials

### Results

In this project, the experimental procedures determined the mechanical properties of 5 materials. The strain rate influence on the tensile and flexural properties was investigated in the range of 2 – 200 mm/min test speed, showing a noticeable influence on the strength and stiffness of the materials. The materials were also tested in a temperature range of -35 °C to 80 °C, showing significant variation in strength, stiffness and also in behavior (Figure 1).

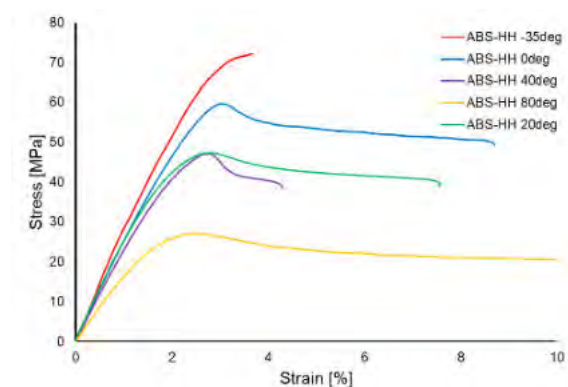

Other experimental procedures included DMA tests and the determination of the Poisson ratio.

The gathered experimental data was used to calibrate elastic-plastic material models for finite element analysis simulations. Temperature and strain-rate dependency was integrated in the models, the material evaluation showing good agreement with the experimental results.

## Applicability and transferability of the results:

The aim of the Bridge Grant was to directly aid companies through the transfer of knowledge, all results being delivered to the project partner:

- The experimental results were supplied to Continental Automotive Romania, the data being used in the material selection process in product design.
- The proposed material models will be used by Continental Automotive Romania in numerical analyses of newly designed components.

## Financed through/by

UEFISCDI

## Research Center

Ștefan Nădășan Laboratory

## Research team

Eng. Dan-Andrei ȘERBAN, PhD – Project manager  
Prof. Eng. Liviu MARȘAVINA, PhD  
Eng. Radu NEGRU, PhD  
Eng. Emanoil LINUL, PhD  
Eng. Corina ȘOȘDEAN, PhD  
Eng. Camelia ARIEȘANU, PhD  
Eng. Gabriel PRAȚA,  
Eng. Adelin ENESCU,  
Eng. Cristian CODRESCU

## Contact information

Dan-Andrei ȘERBAN, PhD  
Faculty of Mechanical Engineering  
Department of Mechanics and Strength of Materials,  
Address: Mihai Viteazu Str., No. 1 Postal Code 300222, Timisoara  
Phone: (+40) 256 403 741  
E-mail: dan.serban@upt.ro

## INTELLIGENT CONTROL SYSTEM FOR CONTINUOUS CASTING BASED ON WATER FLOW CONTROL IN THE SECONDARY COOLING

### Goal of the project:

This project deals with the development of metamaterial structures composed tessellations of mainly two types of open cells: truncated hexahedron tessellation (the Kelvin structure, a) and hollow sphere tessellation (b). The structures will be modelled using computer aided design software and their mechanical properties will be evaluated using finite element analysis software. When the desired geometries will be developed, the CAD file will be exported to a rapid prototyping machine for manufacturing.

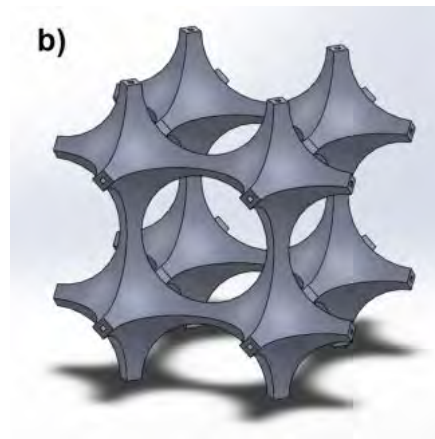
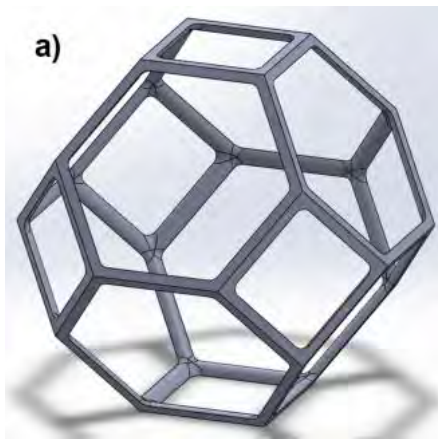

### Short description of the project:

This project addresses a subject in the field of innovative materials and it deals with the design and manufacturing of structures composed of engineered materials whose properties are not found in nature (metamaterials). The metamaterials proposed for this project will consist of cellular polymeric lattices, whose properties will be controlled through geometric parameter manipulation (strut thickness, cell size and shape). The main applications of these structures will be as cushioning and protective layers meant to absorb the deformations and impact energy of personal protective equipment. The project has two main stages. The first stage consists of the design and simulation of the structures in order to determine the optimal parameters in terms of mechanical properties. The second stage of the project will deal with the manufacturing of the structures through rapid prototyping and the experimental determination of their mechanical characteristics. The comparison between the estimated and experimentally determined properties will validate the designs of the structures, allowing for complex geometry modelling for actual safety equipment applications.

### Project implemented by

Politehnica University Timișoara

### Implementation period:

1.5.2018 – 30.4.2020

### Main activities:

01. Literature survey concerning metamaterial structures and additive rapid prototyping techniques.
  - A1.1. Literature study concerning mechanical metamaterial structures
  - A1.2. Literature study concerning rapid prototyping techniques for polymers
02. Development of parametrical metamaterial structures
  - A2.1. Design of metamaterial structures based on Kelvin cells
  - A2.2. Design of metamaterial structures with hollow sphere cells
03. Numerical evaluation of the mechanical properties of the developed metamaterial structures
  - A3.1. Determination of the mechanical properties of the polymers used in rapid prototyping
  - A3.2. Evaluation of the static mechanical properties of the developed structures
  - A3.3. Evaluation of the impact and energy absorption properties of the developed structures
  - A3.4. Optimization of metamaterial structures

- 04. Manufacturing of metamaterial structures
  - A4.1. Parameter adjustment for structure manufacturing through rapid prototyping
  - A4.2. Manufacturing of designed structures through additive rapid prototyping
- 05. Experimental determination of the mechanical characteristics of the manufactured structures
  - A5.1. Elaboration of static tests in compression on the manufactured structures
  - A5.2. Elaboration of static tests in bending on the manufactured structures
  - A5.3. Elaboration of fatigue tests in compression on the manufactured structures
  - A5.4. Elaboration of impact tests on the manufactured structures
- 06. Structure validation and product component design
  - A6.1. Comparison of results and simulation optimization
  - A6.2. Design of safety equipment components based on metamaterial structures
  - A6.3. Numerical analysis of the designed components' behavior in impact applications

## Results:

After the first year of implementation, several structures were generated, and the variation of relative stiffness with the structure parameters was investigated.

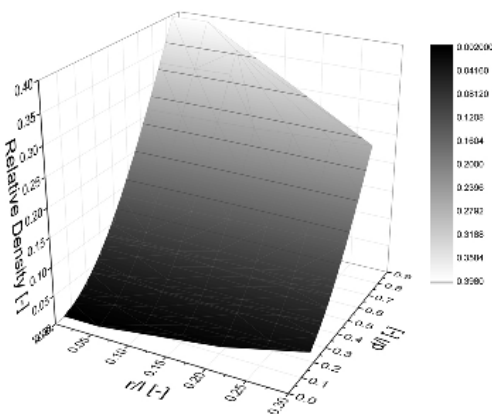

The geometries were imported into a finite element analysis software and the relative stiffness and relative strength variation with relative density was determined.

Partial results were published in an article entitled "A parametric study of the mechanical properties of open-cell Kelvin structures" and presented at the international conference AMS18

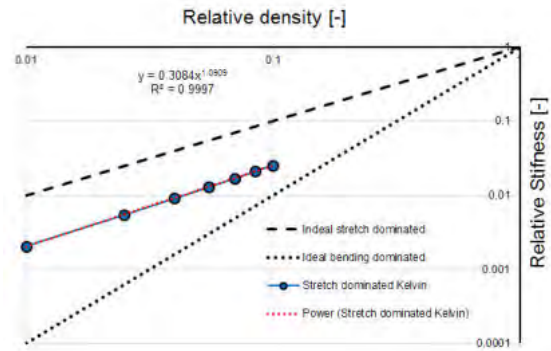

## Applicability and transferability of the results:

The results obtained from this project can be implemented in safety equipment, for various types of industries, such as civil engineering (helmets), sports (protective equipment such as helmets, shin guards, padding), automotive (motorcycle suits) and defense (body and vehicle armor)

## Financed through/by

UEFISCDI

Programul 1 - Dezvoltarea sistemului național de cercetare-dezvoltare

## Research Center

1. Laboratorul Ștefan Nădășan, Politehnica University Timișoara
2. Medical Engineering Research Center, Politehnica University Timișoara
3. ICER - Research Institute for Renewable Energy, Politehnica University Timișoara

## Research team

Eng. Dan-Andrei ȘERBAN, PhD

Prof. Eng. Nicolae FAUR, PhD

## Contact information

Eng. Dan-Andrei ȘERBAN, PhD

Faculty of Mechanical Engineering

Department of Mechanics and Strength of Materials,

Address: 1 Miei Viteazu Blvd., Postal Code 300222, Timisoara

Phone: (+40) 256 403 741

Mobile: (+40) 721 866 598

E-mail: dan.serban@upt.ro

Web: <http://www.dserban.com/PD13-2018/>



## SMART BUILDINGS ADAPTABLE TO THE CLIMATE CHANGE EFFECTS (CIA\_CLIM)

### Goal of the project

The specific objective of the project is centred on the increase of energy efficiency of buildings, by using smart facades with low-thermal transfer and smart energy efficiency through building automatization and solar energy collectors, through a modular laboratory demonstrative application. The resulted system, the smart house, is conceived thus to minimize the input energy for maintenance.

### Short description of the project

The four component projects are focusing on two principal research directions:

- (i) use of smart facades with the low-thermal transfer, actively integrated for the enhancement of internal comfort and possessing a passive control of energy and
- (ii) smart energy efficiency through building automatization and solar energy collectors.



### Project implemented by

Politehnica University Timișoara as coordinator (CO), in collaboration with

- Technical University of Civil Engineering of Bucharest (UTCB, P1),
- Technical University of Cluj-Napoca (UTCN, P2),
- National Institute for R & D in Electrical Engineering Bucharest (ICPE – CA, P3) and
- National Institute of R & D for Electrochemistry and Condensed Matter Timișoara (INCEMC, P4)

### Implementation period

01.03.2018 - 30.09.2020

### Main activities

*Project 1* investigates the mechanical properties of cellular materials used as thermal insulations in smart façade systems, through mechanical compression, bending and toughness fracture testing.

*Project 2* is focused on obtaining, characterizing and testing of high-property materials used for smart facades as thermal insulation materials and as support for special property layers: photo-catalytic layers and with reduced absorption/reflexion of UV-VIS-IR radiation.

*Project 3* investigates the implementation of the electric power distribution in direct current for individual households or in small communities (smart-grid), with renewable energy sources integration.

*Project 4* implements the knowledge and data resulted from projects no. 1-3 through a modular laboratory demonstrative application. The project will perform an integrated study on the influence of the facades and the energetic contribution to the internal comfort of the building.

### Results

- Determination of mechanical properties of cellular materials used as thermal insulations in smart façade systems;
- Production, characterization and testing of high-property materials used for smart facades as thermal insulation materials and as support for special property layers;
- Implementation of the electric power distribution in direct current for individual households or in small communities (smart-grid), with renewable energy sources integration, finalizing with an experimental platform;
- Modular laboratory demonstrative application for the implementation of project results, performing a global study regarding the influence of the facades and the energetic contribution to the internal comfort of the building.



## Applicability and transferability of the results

In the construction domain, the energy represents the key-point in achieving efficient buildings. All the results obtained in the frame of the project are expected to be of interest for the economic environment, from manufacturers to contractors. Design guidelines and recommendations will be provided.

## Financed through/by

The project is supported by a grant of the Executive Unit for Financing Higher Education, Research, Development and Innovation (UEFISCDI), project number PN-III-P1-1.2-PCCDI-2017-0391 / grant agreement 30PCCDI/2018.

## Research Centre

- ICER - The Research Institute for Renewable Energy, UPT (CO);
- "St. Nadasan" Research Laboratory for Strength, Integrity and Durability of materials, structures and conductors, UPT (CO);
- Research Center of Environmental Science and Engineering, UPT (CO);
- Intelligent Control of Energy Conversion and Storage Research Center, UPT (CO);
- ACTEX - Integrated Platform of Research and Development for the Behaviour of Structures under Extreme Actions, UPT (CO);
- CAMBI - Advanced Research Center for Ambiental Quality and Building Physics, UTCB (P1);
- EEC - Energy Efficiency in Buildings, UTCB (P1);
- RLSDEPE - Research Laboratory and Sustainable Development in Electronics and Power Electronics, UTCN (P2);
- Department for Efficiency in Conversion and Consumption of Energy, ICPE - CA (P3);
- Renewable Energies – Photovoltaics – Laboratory, INCEMC (P4);
- Chemical and Electrochemical Synthesis Department, INCEMC (P4).

## Research team

The research team is composed by 90 researchers of the five institutions.

## Contact information

Prof. Viorel UNGUREANU, PhD  
Faculty of Civil Engineering  
Department of Steel Structures and Structural Mechanics  
Address: Str. Ioan Curea, No. 1, 300224, Timișoara  
Phone: (+40) 256 403912  
Mobile: (+40) 740 137640  
E-mail: viorel.ungureanu@upt.ro  
Web: <https://www.icer.ro/cercetare/proiecte-de-cercetare/cia-clim>

## CENTRALIZING AND OPTIMIZING SCADA IN THE WATER SECTOR (CASCADA)

### Goal of the project

The knowledge transfer to Aquatim through software and hardware modules and strategies for centralizing and optimizing SCADA for the water sector.

### Short description of the project

The general purpose of CASCADA is the knowledge transfer to the economic operator through software and hardware modules and strategies to solve stated problems in centralizing and optimizing SCADA for the water sector. The project proposes the ICOM module (Interface, Conversion, Optimization, Modularity) as instrument in solving both interfacing and protocol conversion problems and the development of non-invasive optimization modules of controlling groups of objectives already in function in the water sector. Also, in order to improve effectiveness, the project addresses the IGSS SCADA implementation strategy in Aquatim control center and the existing communication system. CASCADA wants to train Aquatim in SCADA/automation/communications new technologies and to practically apply the concepts in a SCADA analysis of three existing objectives of the operator.

### Project implemented by

Politehnica University Timișoara

### Implementation period

30.09.2016-30.09.2018

### Main activities:

The activities are foreseen to implement the following three objectives:

- 1) Realizing and testing the ICOM module;
- 2) Optimizing the IGSS control center;
- 3) Direct knowledge transfer in new technologies.

### Results

CASCADA, through the ICOM module will solve the SCADA integrability problems of the economic operator, respectively will provide an instrument, independent of local equipment and SCADA solutions, to answer integrability and functioning optimization issues for groups of interdependent objects as technological flow but independent regarding their implementations. Therefore, due to SCADA correlations of groups of objects (integrations on higher SCADA levels and creating control algorithms for group of objects), the economic operator's systems will be more stable and efficient, respectively the impact of the incidents will be reduced. Optimizing the IGSS control center will provide the possibility to

maximally use the resources available through licensing, an increased communication speed through systematizing the internal Aquatim network, respectively an adequate web based access conferred by the WebNavIGSS module.

CASCADA will impact also the quality of the future investments of the economic operator through opening perspectives to new technologies and optimal solutions, with increased efficiency and reduced costs.

The implemented activities will strengthen the entrepreneurial abilities of researchers and the connection between the academic environment and the industry requirements.

### Applicability and transferability of the results

As a bridge grant, the project is strongly industry oriented, with significant practical value and focused on the knowledge transfer to an economic operator.

### Financed through/by

UEFISCDI

### Research Centre

ICER – Renewable energy research institute

### Research team

Adrian Ștefan KORODI  
Ioan SILEA  
Octavian ȘTEFAN  
Ruben Dan CRIȘAN  
Teodor HUPLE  
Alexandra-Ionela BASSO-ȚIDREA  
Mihaiță-Alin RADU  
Mihaela Marcella CRIȘAN-VIDA  
Oana-Sorina CHIRILA

### Contact information

Assist. Prof. Adrian Ștefan KORODI, PhD  
Faculty of Automation and Computers,  
Department of Automation and Applied Informatics  
Address: Str. V. Parvan, No. 2, 300223, Timișoara  
E-mail: adrian.korodi@upt.ro

## NATURE-INSPIRED MODELING AND OPTIMIZATION TECHNIQUES OF FUZZY CONTROL SYSTEMS WITH MECHATRONICS APPLICATIONS

### Goal of the project

The aim of this project is to demonstrate efficiency and prove the viability of an innovative tuning approach for fuzzy control systems using nature-inspired algorithms in control structures modeling and optimization stages. In this framework, combining nature-inspired optimization algorithms with fuzzy control structures, will have a significant impact on the performance of fuzzy control systems.

### Short description of the project

The nature-inspired optimization algorithms will be employed in solving optimization problems that minimize discrete-time objective functions expressed as integral or sum-type quadratic performance indices.

### Project implemented by

Politehnica University Timișoara

### Implementation period

19.10.2018 - 18.10.2020

### Main activities:

The main activities are:

1. Development of efficient control solutions for different processes by bypassing the higher derivative calculations;
2. Takagi-Sugeno fuzzy controllers' optimization through minimization of several objective functions;
3. Development of performant solutions with a reduced implementation cost;
4. Experimental validation of proposed control solutions;
5. Achievements dissemination in high visibility journals and conferences;
6. Successful project management administration.

### Results

The main results are related to development of nature inspired algorithm-based solutions for solving optimization problems of fuzzy systems will be disseminated at national and international levels as: four papers published in Thomson Reuters Web of Science (formerly known as ISI Web of Knowledge) publications and four presentations at international conferences.

### Applicability and transferability of the results

The results obtained during this contract belong exclusively to Politehnica University Timișoara.

### Financed through/by

Executive Agency for Higher Education, Research, Development and Innovation Funding

### Research Centre

Faculty of Automation and Computers

### Research team

Eng. Radu-Codruț DAVID, PhD  
Prof. eng. Stefan PREITL, PhD

### Contact information

Eng. Radu-Codruț DAVID, PhD  
Faculty of Automation and Computers  
Department of Automation and Applied Informatics  
Address: Bd. V. Parvan 2, 300223 Timisoara, Romania  
Phone: (+40) 722 254450  
E-mail: davidradu@gmail.com  
Web: aut.upt.ro

## SINTERING OF NOVEL STRUCTURES FOR ALLOYS WITH INCREASED FUNCTIONALITY

### Goal of the project

The proposed research involves collaboration based on the complementary experience of the two groups for obtaining sintered materials (including porous or gradient) from the intelligent material family. Focusing is on emphatic forms of the form, including biocompatible (from the NiTi family).

### Short description of the project

The collaboration will use the experience of the research groups in Romania and China for the development of new technologies in order to manufacture high-performance intelligent materials.

### Project implemented by

- Politehnica University Timișoara
- University of Science and Technology Beijing

### Implementation period

2018 - 2019

### Main activities:

1. Preparation and characterization of complex metal powders
2. Identify the compatibility between the potentially usable components in making porous structures
3. Establishing technologies for making sintered materials
4. Making and characterization of sintered materials.

### Results

Expected results:

- Metal powders and mechanical alloying;
- Couples of materials for porous structures;
- Components with controlled geometry for porosity;
- Conventional, plasma and laser sintering technologies;
- Characterized materials;
- Dissemination.

### Applicability and transferability of the results

The results can be applied in the biomedical industry

### Financed through/by

UEFISCDI – Romania-China bilateral partnerships

### Research Centre

Smart Materials Laboratory

### Research team

Prof. Corneliu M. CRACIUNESCU, PhD  
Roxana SPRANCENATU, PhD student  
Andrei NOVAC, PhD student  
George Gheorghe CHILNICEAN, PhD student

### Contact information

Prof. Corneliu CRACIUNESCU, PhD  
Faculty of Mechanical Engineering /  
Department of Materials and Manufacturing Engineering  
Bd. Mihai Viteazul , No. 1 Postal Code 300025, Timisoara  
Phone: (+40) 256 403 655  
E-mail: corneliu.craciunescu@upt.ro  
Web:[http://www.upt.ro/img/files/2018-2019/cercetare/ppr/Proiect\\_RO-CN-SINS.pps](http://www.upt.ro/img/files/2018-2019/cercetare/ppr/Proiect_RO-CN-SINS.pps)

## DEVELOPMENT OF ECO-FRIENDLY COMPOSITE MATERIALS BASED ON GEOPOLYMER MATRIX AND REINFORCED WITH WASTE FIBRES

### Goal of the project

The project is an answer for a specific challenge regarding waste management, recycling and urban mining. The goal of the project is to prepare a broad spectra of advanced and progressive new composite materials based geopolymer matrices and reinforced with natural waste fibres. The application of these new materials will be the construction industry with a high potential of commercial utilization and potential replacement of conventional materials.

### Short description of the project

This project deals with the development of new composite materials for construction industry, based on waste products.

### Project implemented by:

Project coordinator: Cracow University of Technology.

Partners: Nigde University Turkey, Pontificia Universidad Católica del Peru, Riga Technical University Latvia, Babeş-Bolyai University, Catholic University of Uruguay Damas Antonio Larrañaga, Politehnica University Timișoara.

### Implementation period

02/01/2017 – 31/12/2019

### Main activities

- WP1. The selection of waste materials for hydrothermal alkalization and therefore to be turned into new materials based on geopolymer matrix for construction applications
- WP2. The selection of waste materials (natural fibres) as a fillers and therefore turned into new composites for construction application
- WP3. Optimization of properties using computer methods for the new materials and structural elements
- WP4. The research into the application of new materials – comparison of the functional properties of the materials
- WP5. Analysis of practical applications of new materials for construction application and testing prototype components in laboratory as well as validated it in relevant environment

### Results

The year 2017 had deadlines for the first two Work Packages. WP1, coordinated by Nigde University, dealt with the identification of waste materials for the composite material matrices. Each participating partner performed a survey of possible waste material candidates available in their region (recycled clay bricks and volcanic ash in Peru, fly ash in Turkey, Argentina and Romania, paper mill sludge and rice husk ash in Uruguay and granulated rubber from waste tyres in Poland).

WP2, coordinated by Babeş-Bolyai University, dealt with the identification of waste natural fibres as reinforcements for the composites. As with WP1, each participating partner proposed waste materials available in their region (mostly hemp and flax fibres).

### Applicability and transferability of the results:

The new composite materials that will be developed in this project will be tested and their properties compared with conventional construction materials. If the mechanical and thermal behaviour is comparable between the two categories, the newly developed materials will be proposed for replacing traditional materials in each specific region where the waste products are available.

### Financed through/by

Horizon 2020 - ERA Net Latin America and Caribbean Countries/UEFISCDI

### Research Center

Ștefan Nădășan Laboratory

### Research team

Eng. Dan-Andrei ȘERBAN, PhD – Project manager  
Prof. Eng. Liviu MARȘAVINA, PhD  
Eng. Radu NEGRU, PhD  
Eng. Emanoil LINUL, PhD

### Contact information

Eng. Dan-Andrei ȘERBAN, PhD  
Faculty of Mechanical Engineering  
Department of Mechanics and Strength of Materials,  
Address: Mihai Viteazu Str., No. 1 Postal Code 300222, Timisoara  
Phone: (+40) 256 403 741  
E-mail: dan.serban@upt.ro

# Research and Development Projects for Young Researchers





## COMPLEX-VALUED DEEP NEURAL NETWORKS

### Goal of the project

Three types of complex-valued deep neural networks will be proposed: complex-valued convolutional neural networks, complex-valued deep belief networks and long short term memories, which will be applied for image recognition and time series prediction with real values and with complex values.

### Short description of the project

The project aims to extend deep neural networks to the complex domain, and use the resulting complex-valued deep neural networks for real- and complex-valued image recognition and time series prediction.

### Implementation period

21.11.2017 – 31.12.2018

### Budget

46.500 RON (10000 EUR)

### Main activities

The main activities of the project are:

- Development and application of deep complex-valued convolutional neural networks,
- Development and application of complex-valued deep belief networks,
- Development and application of complex-valued long short term memories,
- Dissemination of the results and support of the research activities.

### Results

The main results of the project were: 5 papers in ISI conferences:

- **3 at the International Symposium on Neural Networks (ISNN)**, Minsk, Belarus, 2018:
  1. C.-A. Popa, C. Cernăzanu-Glăvan, Fourier Transform-Based Image Classification Using Complex-Valued Convolutional Neural Networks;
  2. C.-A. Popa, Complex-Valued Stacked Denoising Autoencoders;
  3. C.-A. Popa, Complex-Valued Deep Belief Networks;

- **2 at the International Joint Conference on Neural Networks (IJCNN)**, Rio de Janeiro, Brazil, 2018:

1. C.-A. Popa, Deep Hybrid Real-Complex-Valued Convolutional Neural Networks for Image Classification;
2. C.-A. Popa, Complex-Valued Deep Boltzmann Machines;

- **and 2 papers in ISI journals:**

1. C.-A. Popa, Deep Hybrid Real-Complex-Valued Residual Networks, IEEE Access, IF 3.557, Q1;
2. C.-A. Popa, Global  $\mu$ -Stability of Neutral-Type Impulsive Complex-Valued BAM Neural Networks with Leakage Delay and Unbounded Time-Varying Delays, Neurocomputing, IF 3.241, Q1.

### Applicability and transferability of the results:

The results are applicable in the radar imaging and the functional magnetic resonance imaging domains, which both produce complex-valued images, where complex-valued neural networks can have better results than their real-valued counterparts. Wind speed and direction prediction is a complex-valued time series prediction problem, for which the proposed complex-valued neural networks may also have a positive impact. As such, the results can be interesting for the military, medical, and metrological domains.

### Research team

Călin-Adrian POPA, Project Director  
Cosmin CERNĂZANU-GLĂVAN, Member

### Contact information

Assist. Prof. Călin-Adrian POPA, PhD  
Faculty of Automation and Computing  
Department of Computer and Software Engineering  
Address: Blvd. V. Pârvan, No. 2, 300223, Timișoara  
Phone: : (+40) 256 404 0611  
E-mail: calin.popa@cs.upt.ro  
Web: <http://cs.upt.ro/~cpopa>

## TENSOR PRODUCT MODEL TRANSFORMATION-BASED ADAPTIVE CONTROL TECHNIQUES WITH MECHATRONICS APPLICATIONS

### Goal of the project

The main goal of this project was the analysis, the development and the validation of the control algorithms, which combines new tensor product model transformation-based design techniques, fuzzy control and adaptive control. The exploitation and dissemination of results in the refereed journals and in refereed academic conferences.

### Short description of the project

Derivation of LPV models of mechatronics applications using TP-based model transformation. Mixed TP-based and adaptive control algorithms are designed for the control of laboratory equipment.

### Implementation period

21.11.2017 – 31.12.2018

### Budget

46.500 RON (10000 EUR)

### Main activities

1. The analysis, development and implementation of new Tensor Product model transformation-based design techniques.
2. The development of mixed control algorithms by the combination of new Tensor Product based model transformation fuzzy control and gain scheduling control. The stability analysis of the closed-loop control systems.
3. The exploitation and dissemination of results, the publication of papers in high impact leading journals. The participation and presentation of papers to important conferences. The continuous development of international partnerships.
4. The management of activities.

### Results

The main results of the project were:

- Bojan-Dragoş et al., Gain-Scheduling Control Solutions for Magnetic Levitation Systems, APH
- Hedrea et al., TP-Based Model Transformation Technique Applied to Modeling Vertical Three Tank Systems, SACI2018
- Bojan-Dragoş et al., Control Solutions for Vertical Three-Tank Systems, SACI2018

- Szedlak-Stinean et al., Feedback Control Solutions for an Electromechanical Process with Rigid Body Dynamics, SACI2018
- Szedlak-Stinean et al., Gain-Scheduling Control Solutions for a Strip Winding System with Variable Moment of Inertia, PID2018
- Hedrea et al., Comparative Study of Control Structures for Maglev Systems, PEMC2018
- Hedrea et al., Cascade Control Solutions for Maglev Systems, ICSTCC2018
- Bojan-Dragoş et al., Gain-Scheduling Position Control Approaches for Electromagnetic Actuated Clutch Systems, ICINCO2018.

### Applicability and transferability of the results:

New TP fuzzy techniques can lead to automatic tools for controller design and tuning in several control system structures. All mechatronics applications tackled in the project are interdisciplinary and multidisciplinary themselves. The new TP fuzzy techniques proposed in this project are dedicated to process control in many industry areas which are managed by the team partners.

### Research team

Claudia-Adina BOJAN-DRAGOŞ, Project Director  
Mircea-Bogdan RĂDAC, Member  
Alexandra-Iulia SZEDLAK-STÎNEAN, Member

### Contact information

Assist. Prof. Claudia-Adina BOJAN-DRAGOŞ, PhD  
Faculty of Automation and Computing  
Department of Automation and Applied Informatics  
Address: Blvd. V. Pârvan, No. 2, 300223, Timișoara  
Phone: (+40) 256 403 240  
Mobile: (+40) 738 283 682  
E-mail: claudia.dragoş@upt.ro

## NEW MATERIALS CHEMICALLY MODIFIED USED FOR ARSENIC ADSORPTION FROM WATER

### Goal of the project

The goal of the project is to obtain advanced materials functionalised with crown ethers which could be efficiently used in the removal process of arsenic from waters.

### Short description of the project

In full accordance with the principle of sustainable development, the project presents a new concept for arsenic removal treatment of drinking water, using innovative systems involving new adsorbent materials. Why arsenic? Because arsenic is a national and worldwide problem. At the same time its toxicity is well known. Also, in the developing countries the underground waters represent the main source of drinkable water and their contamination with arsenic compounds is a problem that must be solved. There are many methods of arsenic removal from drinking water, like filtration, precipitation, coagulation, electrocoagulation, invers osmoses and ion exchange.

Adsorption is one of the most commonly method reported. Adsorption processes involving arsenic are considered to be rapid, depending on the material nature. Therefore, in order to reduce the negative impact of arsenic towards human health it is necessary to find some new materials for its removal.

For this reason, the project is focused on obtaining new materials for arsenic removal from drinking water, which have a good potential due to their low cost, eco-friendliness and low environmental impact.

### Implementation period

21.11.2017 – 31.12.2018

### Budget

46.500 RON (10000 EUR)

### Main activities

The main objective of the project is to investigate an original approach, regarding

- (i) the obtaining of new materials chemically modified through functionalization with crown ethers and loaded with iron ions,
- (ii) use of these materials as adsorbent in the view of arsenic removal from waters and
- (iii) the reprocessing of these materials through refunctionalization.

The research presents an absolute novelty and has an exploratory character by obtaining of some new functionalized materials for arsenic removal, and through their reprocessing, after exhaustion bringing fundamental elements in the building of young research team, able for competition in the frame of European programmes.

### Results

The results dissemination of the research are take in:

- 2 articles in ISI indexed journals;
- 2 articles in ISI-Proceedings;
- 6 papers are communicated and published in the specialty conferences volumes (Water Pollution XIV, 22-24 May 2018, Coruna, Spain; Polymers and Organic Chemistry 2018 (POC 2018) 4-7 June, Montpellier, France, 30.09-3.10. 2018, Bor Lake, Serbia, 11-12.10.2018, Timișoara, Romania)

### Applicability and transferability of the results:

- Project could have a potential impact on Waters Utilities, Institutes of Public Health and Veterinary Health Directorates in the West Area.
- This project assumes an interdisciplinary approach which will elucidate the mechanism of arsenic removal from water through adsorption on chemically modified materials through functionalization with crown ethers and loaded with iron ions.
- Improved university-industry relationships.

### Research team

Mihaela CIOPEC, Project Director  
Narcis DUTEANU, Member  
Iosif HULKA, Member  
Ana-Maria PANA, Member

### Contact information

Assist. Prof. Mihaela CIOPEC, PhD  
Faculty of Industrial Chemistry and Environmental Engineering,  
Department of Inorganic and Applied Chemistry and Environmental  
Engineering  
Address: Blvd. V. Pârvan, No. 6, 300223, Timișoara  
Phone: (+40) 256 404192  
Mobile: 0722806880  
E-mail: mihaela.ciopec@upt.ro

## MULTIPHASE CONVERTERS FOR SOLAR ENERGY CONVERSION AND BATTERY CHARGING IN ELECTRIC VEHICLES

### Goal of the project

Proposal of two new dc-dc multiphase converter families suitable in solar energy processing and battery charging systems.

### Short description of the project

The multiphase Boost family exhibits higher static conversion ratio while maintaining a smooth input current and high efficiency.

The Buck family consists of topologies prone to be used in battery charging because of smooth output current.

### Implementation period

21.11.2017 – 31.12.2018

### Budget

46.500 RON (10000 EUR)

### Main activities

Activity 1.1. Synthesis of a multiphase converter family based on the C-Step Down cell.

Activity 1.2. Converters design.

Activity 1.3. Model validation by simulation.

Activity 1.4. Equipment purchase.

Activity 1.5. Synthesis of a multiphase converter family based on the L-Step Up cell.

Activity 1.6. Converters design.

Activity 1.7. Model validation by simulation.

Activity 1.8. System architecture for solar energy conversion system using L-SU topology.

Activity 1.9. Component purchase.

Activity 1.10. Participation at the SACI 2018 Conference.

Activity 1.11. Practical implementation of converters. Hardware testing and practical measurements.

Activity 2.1. Payment of participation fee for EPE and PEMC conference.

Activity 2.2. System architecture for solar energy conversion system using L-SU topology. Practical measurements.

Activity 2.3. Defending the paper at the PEMC 2018 Conference.

Activity 2.4. Defending the paper at the EPE 2018 Conference.

Activity 2.5. Battery charging system based on C-SD converters topologies. Measurements and system evaluation.

Activity 2.6. Defending the paper at the ISETC 2018 Conference.

Activity 2. Paper sent to an ISI journal (letter accepted and published).

### Results

The proposed topologies were validated by experiment and by being published at the following international conferences and journal.

1. I-M. Pop-Calimanu, S. Lica, S. Popescu, D. Lascu, I. Lie, R. Mirsu, „A New Hybrid Inductor-Based Boost DC-DC Converter Suitable for Applications in Photovoltaic Systems”, „Energies”, vol. 12, no.2.
2. I-M. Pop-Calimanu, S. Lica, F. Renken, R. Mirsu, G. Simion, I. Lie – „A Comparison Between Single-Phase and Two-Phase Hybrid Boost-L Converter”, International Symposium on Electronics and Telecommunications 2018, Timisoara, Romania.
3. I-M. Pop-Calimanu, S. Lica, D. Lascu, F. Renken – „A Novel Hybrid Buck-L Converter”, 20th European Conference on Power Electronics and Applications – EPE'18 ECCE Europe, Riga, Latvia.
4. I-M. Pop-Calimanu, S. Lica, D. Lascu, F. Renken, M. Gurbina, R. Mirsu – „A Novel Hybrid Step-Down DC-DC Converter”, 18th International Conference on Power Electronics and Motion Control – IEEE-PEMC 2018, Budapest, Hungary
5. M. Gurbina, I-M. Pop-Calimanu, D. Lascu, S. Lica, A. Ciresan – „Exact Stability Analysis of a Two-Phase Boost Converter”, 41st International Conference on Telecommunications and Signal Processing, Athens, Greece.
6. I-M. Pop-Calimanu, R. Mirsu – participation at the 12th International Symposium on Applied Computational Intelligence and Informatics (SACI 2018), Timisoara, Romania.
7. I-M. Pop-Calimanu – participation at the tutorial „Fast Charging Ready? Infrastructure, Topologies and Key Enabling Components, EPE'18 ECCE Europe, Riga, Latvia.

### Applicability and transferability of the results:

Companies producing and implementing equipment for PV based systems can easily adopt the Boost family as also a MPPT algorithm is provided and a system is presented in order to prove its applicability. For low power chargers automotive companies can take benefit of the new multiphase Buck converter.

### Research team

Ioana-Monica POP-CĂLIMANU, Project Director

Radu MIRSU, Member

Georgiana SIMION, Member

### Contact information

Assist. Prof. Ioana-Monica POP-CALIMANU, PhD

Faculty of Electronics, Telecommunications and Information

Technology, Department of Applied Electronics

Address: Blvd. Vasile Pârvan, No. 2, 300223, Timișoara

Phone: (+40) 256 403 347

Mobile: (+40) 741 182 224

E-mail: ioana-m.pop@upt.ro

## LORA - INTELLIGENT INFRASTRUCTURE FOR COMMUNICATIONS AND DECISION SUPPORT IN POWER SYSTEMS

### Goal of the project

The main goal of this project is to create an IoT research and didactic laboratory, based on the LoRa technology and the LoRaWAN communication protocol, in which IoT devices will be developed for electrical and power systems applications.

### Short description of the project

Enhance existing techniques, develop new ones in term of IoT applications for electrical and power engineering fields.

### Implementation period

21.11.2017 – 31.12.2018

### Budget

46.500 RON (10000 EUR)

### Main activities

During this project, the research team was focused on the following activities:

- Artificial intelligence algorithms adaptation, more precisely the swarm algorithms, to the requirements of the power engineering field;
- Developing different type of monitoring devices, based on the LoRaWAN communication protocol;
- Developing web based platforms for processing and analyzing the data coming from the monitoring devices;
- Equipping a laboratory with LoRaWAN-compatible equipment for further research and their integration into the teaching process;
- Validation of research results, attending international conferences and publishing results in prestigious journals.

### Results

Team achievements within this project:

- a device that transforms a regular electricity meter into a smart one - using LoRaWAN communication protocol;
- an environment monitoring device for photovoltaic parks - using LoRaWAN communication protocol;

### Results - continuation

- web-based application for processing and analyzing the data coming from the monitoring devices;
- scientific papers accepted for publication:
  - 4 in conference proceedings indexed in Thomson Reuters Web of Science (WoS),
  - 4 papers published in conference proceedings indexed in international databases,
  - 1 paper in WoS journals with impact factors and
  - 1 book chapter in a Springer-Verlag volume.

### Applicability and transferability of the results:

- Through developed devices, the authors have demonstrated that old meters need not necessarily be replaced but can easily transformed into smart ones.
- Also, with the help of environmental monitoring devices for photovoltaic parks, it is possible to make better forecasts of electricity generation.

### Research team

Attila SIMÓ, Project Director

Claudia-Adina BOJAN-DRAGOȘ, Member

### Contact information

Assist. Prof. Attila SIMÓ, PhD

Faculty of Electrical and Power Engineering,

Department of Power Engineering

Address: Blvd. Vasile Pârvan, no. 2, RO-300223, Timișoara, România

Phone: (+40) 256 403430

E-mail: attila.simo@upt.ro

Web: <http://et.upt.ro/ro/staff/%C5%9Fldring-attila-sim%C3%B3>

## OPTIMIZING RISK REDUCTION STRATEGIES FOR GEOMORPHOLOGICAL HAZARDS BY 3D MODELING

### Goal of the project

The project aims to optimize risk reduction strategies for geomorphological hazards by their 3D modeling in the context of Romania's susceptibility and poor management of local authorities who are insufficiently prepared to manage such situations.

### Short description of the project

Landslides are complex phenomena regarding the effects they produce; thus representing a risk factor to be assessed and quantified. 3D modeling of geospatial data characteristic to landslides acquired using TLS technology and UAVs is useful for monitoring and determining the risk potential of certain areas.

### Implementation period

June 2018–June 2019

### Budget

46.500 RON (10000 EUR)

### Main activities

Preliminary research was realized in order to choose a pilot study area. Then data collection on field involved using 2 different technologies, namely Terrestrial Laser Scanning and Unmanned Aerial Vehicle (drone). Further, the geospatial data acquired was processed using specialized software in order to obtain the 3D model of the landslide from the pilot study area. A comparative study of the 3D models realized is also of interest in order to determine particularities of the 2 technologies. The final part of the project includes optimizing risk reduction strategies for geomorphological hazards.

### Results

The results are useful for managing the destructive effects of geomorphologic hazards on the environment and to optimize their forecasting and post-factum approaches.

### Applicability and transferability of the results:

The geodetic engineer participates to the acquisition, manipulation, visualization and analysis of geospatial data characteristic of hazards in order to adopt the most appropriate methods of protecting and preserving the environment in order to adapt to climate change. Knowledge transfer and dissemination of project results is aimed at raising awareness organizations, both public and private, that are active in geodesy and civil engineering.

### Research team

Clara – Beatrice VÎLCEANU, Project Director  
Anca – Maria MOSCOVICI, Member  
Rareş HĂLBAC-COTOARĂ-ZAMFIR, Member  
Luiza Andreea ROMAN, Member

### Contact information

Assist. Prof. Clara-Beatrice VÎLCEANU, PhD  
Faculty of Civil Engineering  
Department of Overland Communication Ways, Foundations and Cadastral Survey  
Address: Str. Traian Lalescu 2, 300223, Timișoara  
Phone: (+40) 256 403983  
Mobile: +40742077325  
E-mail: [beatrice.vilceanu@upt.ro](mailto:beatrice.vilceanu@upt.ro)  
Web: <https://orcid.org/0000-0002-0710-5089>  
[https://www.researchgate.net/profile/Clara\\_Beatrice\\_Vilceanu/research](https://www.researchgate.net/profile/Clara_Beatrice_Vilceanu/research)

## REDUCING FUEL CONSUMPTION OF INTERNAL COMBUSTION ENGINE BY RECOVERING LOST ENERGY

### Goal of the project

The problem of polluting emissions in the field of transport is becoming more and more stringent, so there is a general interest in finding solutions to reduce pollutant emissions and fuel consumption.

### Short description of the project

The following major objectives were proposed:

1. Reduction of pollutant emissions produced by ICE;
2. Reducing fuel consumption by recovering dissipated energy;
3. Increasing global thermal efficiency;
4. Increase the level of knowledge.

For the ICE exhaust heat recovery two system were proposed:

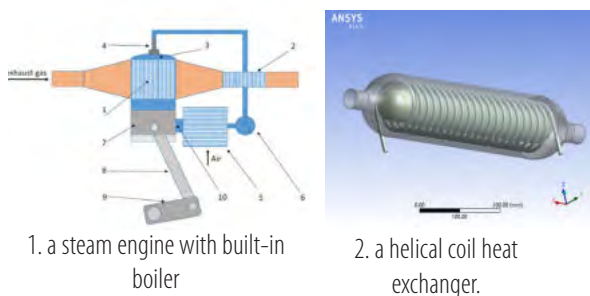

1. a steam engine with built-in boiler

2. a helical coil heat exchanger.

For experimental trials of the proposed system, three internal combustion engine stands have been upgraded and put into operation.

### Implementation period

21.11.2017 – 31.12.2018

### Budget

46.500 RON (10000 EUR)

### Main activities

During this project, the research team was focused on the following activities:

- Development of a mathematical model and simulation of a built-in instantaneous steam boiler engine.
- Verification design of Dynamic Vapor Testing Cell for verifying the developed mathematical model.
- Modernization of three internal combustion engine stands to be used for the study of energy recovery.
- Elaboration of the helical spiral boiler model for FEM analysis.
- Preliminary trials were carried out with the three internal combustion engine stands.

### Results

As a result of the activities carried out, a paper was submitted to an ISI journal and 4 papers were presented within international conferences and the papers are classified as ISI proceedings.

- 1. Vaporization of thin film in case of vapor bubbles. New resolution approach, Virgil Stoica, Mariana Ilie.
- 2. Flash boiling steam engine, Virgil Stoica, Gavrilă Trif-Tordai, Mariana Ilie, Delia Calinoiu,
- 3. Experimental bench test for boiling dynamics, Virgil Stoica, Mariana Ilie, Andrei Borborean, Cioabla Adrian, Dorin Lelea,
- 4. Test Bench for the Effects of Water Injection in an Internal Combustion Engine, Andrei Tiberiu Borborean, Virgil Stoica, Dorin Lelea,
- 5. Application of Biogas Inside and Motogenerator – Case Study, Adrian Eugen Cioabla, Virgil Stoica, Francisc Popescu.

### Applicability and transferability of the results:

The results obtained to date show that the simple injection of water in the case of internal combustion engines involves a 30% reduction of nitrogen oxides emissions. This solution can be applied with low-costs on series internal combustion engines.

The project being focused on practical solutions applicable in everyday life, we expect that the on-coming results due to project implementation, to be practically applicable in industry.

### Research team

Virgil STOICA, Project Director  
Gavrilă TRIF-TORDAI, Member  
Adrian CIOABLA, Member

### Contact information

Assist. Prof. Virgil STOICA, PhD  
Faculty of Mechanical Engineering  
Department of Mechanical Engineering, Machinery and Transportation  
Address: Blvd. Mihai Viteazu, No. 1 300222, Timișoara  
Phone: (+40) 256 403 671  
E-mail: virgil.stoica@upt.ro

## MECHANICAL CHARACTERIZATION OF ADVANCED COMPOSITE STRUCTURES WITH ALUMINUM FOAM CORE

### Goal of the project

The main objective of this project was the development and mechanical characterization of advanced composite structures with aluminum foam core (TUSAA), both for the purpose of professional development of the young researchers involved in this project, as well in order to increase the scientific visibility of the Politehnica University Timișoara.

### Short description of the project

This project focuses on the compressive performances of thin-walled steel tubes filled with closed-cell aluminum-alloy foam. For this purpose, the compressive behavior of empty and ex-situ foam-filled tubes were experimentally and numerically evaluated under different loading conditions (quasi-static / impact loading, uniaxial / lateral loading - see the figure below, room / high temperatures).

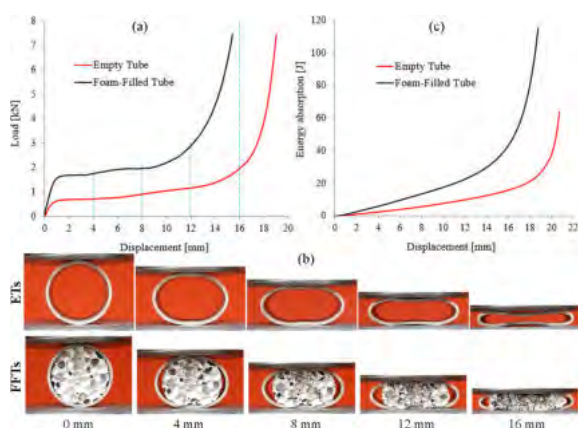

Load-displacement/energy-displacement curves (a,c) and deformation sequences (b) of empty and foam filled tube.

### Implementation period

21.11.2017 – 31.12.2018

### Budget

46.500 RON (10000 EUR)

### Main activities

1. Design and manufacture of TUSAA composites;
2. Mechanical characterization of TUSAA composites;
3. Micro-structural analysis to highlight TUSAA degradation;
4. Numerical analysis of TUSAA composites.

### Results

1. Publication of 9 scientific papers in the ISI circuit, of which 8 as the first author, as follows:

- 5 papers in ISI journals with impact factor:
    - Composite Structures (Q1, IF=4,101);
    - Journal of Alloys and Compounds (Q1, IF=3,779);
    - Engineering Fracture Mechanics (Q1, IF=2,580);
    - Polymers (Q1, IF=2,935);
    - Materials (Q2, IF=2,467).
  - 4 papers in ISI Proceedings (IOP Conference Series: Materials Science and Engineering volume).
2. Participation at 2 international conferences of the project manager and two members of the research team:
- The 7th Int. Conf. on Adv. Materials and Structures, Timisoara (Romania), <http://ams.upt.ro/>;
  - The 21st Int. Conference on Composite Structures, Bologna (Italy), <https://events.unibo.it/iccs21>.

### Applicability and transferability of the results:

Metallic Foams (MFs) have grown considerably over the past 20 years, both from a technological point of view and through the achievement of high mechanical properties. Thus, the use of MFs has experienced a major spread from the automotive industry (filling stiffening elements with MFs in order to increase energy absorption capacity), to civil engineering (panels and heaters made of MFs).

### Research team

Emanoil LINUL, Project Director  
 Dan-Andrei SERBAN, Member  
 Sergiu GALATANU, Member

### Contact information

Asist. Prof. Emanoil LINUL, PhD  
 Faculty of Mechanical Engineering  
 Department of Mechanics and Strength of Materials,  
 Address: Blvd. Mihai Viteazu, no. 1, 300 222, Timisoara, Romania  
 Phone: (+40) 256 403 741  
 Mobile: (+40) 728 440 886  
 E-mail: [emanoil.linul@upt.ro](mailto:emanoil.linul@upt.ro)  
 Web: <http://www.mec.upt.ro/rezi/>



## OBTAINING AND CHARACTERIZING OF BULK AMORPHOUS STEELS

### Goal of the project

This project was aimed processing and characterization of bulk amorphous steels from the Fe-Cr- (Mo, Mn) - (Y, Ga) -C- (B, Si, P) family by casting in copper mold and using ferro-alloys as raw materials.

### Short description of the project

Two families of alloys were studied: Fe-Cr-Mo-Nb-C-Si-Ga and Fe-Cr-Mo-Nb-C-Si-Y.

There were obtained alloys in the form of  $\varnothing 3 \times 50$  mm bars and in the form of discs of  $\varnothing \square 10 \times 1$  mm by pressure casting in cooper mold method (fig.1).

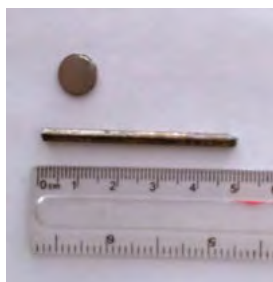

Fig. 1 Obtained alloys

The structural analysis showed that both alloys with Ga and Y have the amorphous structure at concentrations of at least 4% at. Ga and Y respectively.

The obtained alloys have good thermal stability (crystallization temperature,  $T_x$ , is over 630oC), but Ga alloy has a better glass forming ability (GFA).

The alloy with Ga has mechanical strengths,  $R_m$ , and corrosion resistance, expressed by the corrosion rate,  $v_{cor}$ , superior to alloy with Y but is fragile. Y-alloys instead have a ductile behavior, having plastic deformation before breaking.

### Implementation period

21.11.2017 – 31.12.2018

### Budget

46.500 RON (10000 EUR)

### Main activities

- The establishment of the optimal composition of the master alloy;
- Elaboration and characterization of the master alloy;
- Optimizing chemical composition based on structural analysis;
- Constructional-technological design of copper molds for alloy casting;
- -Establishing the casting technology of the alloy developed in the form of cylindrical bars or discs;
- Structural characterization of obtained alloys;
- Determination of mechanical properties;
- Determination of corrosion resistance.

### Results

1. Project team members participated in two international conferences:

- 7th International Conference on Advanced Materials and Structures, AMS 2018, March 28-31, 2018, Timișoara, with the paper "Simulation of Thermal Field in Bulk Amorphous Steels" - ISI Quoted Conference;
- The 25th International Symposium on Metastable, Amorphous and Nanostructured Materials (ISMANAM 2018), 2-6 July 2018, Rome, Italy, with the paper "Synthesis and characterization of bulk amorphous steel using industrial ferro-alloys" - selected papers will be published in ISI quoted journals

2. An article "Influence of Co substitution for Cr on glass forming ability and mechanical properties in Fe-based bulk metallic glass" was sent to HELIYON - Elsevier magazine, accepted for publication with revised manuscript.

### Applicability and transferability of the results:

Bulk amorphous steel (BAS), has drawn great attention for structural and functional applications due to the unique properties such as high fracture strength, high hardness, excellent corrosion resistance. In addition, the Fe-based BAS can be fabricated by using industrial ferrous-alloys, significantly reducing the production cost. Consequently, Fe-based BAS can be an excellent choice for medical implants, surgical tools and other biomedical related parts. They can also be used in fabrication of microgear for micromotors.

### Research team

Cosmin CODREAN, Project Director

Carmen OPRIȘ, Member

Dragoș BUZDUGAN, Member

Iosif HULKA, Member

### Contact information

Assoc.Prof. Cosmin CODREAN, PhD

Faculty of Mechanical Engineering

Department of Materials and Manufacturing Engineering

Address: Blvd. Mihai Viteazu, No. 1, Postal Code RO-300222, Timisoara

Phone: (+40) 256 403 647

E-mail: cosmin.codrean@upt.ro

## INNOVATIVE MECHATRONIC DEVICES FOR RECONFIGURATION AND REUSE OF PACKAGING

### Goal of the project

The basic idea of the project is to create and develop a mechatronic device to reconfigure a packaging of conventional materials which, until its recycling can be reused for another purpose.

### Short description of the project

The packaging reconfiguration device is supposed to be a small flexible manufacturing cell composed of an adaptable “two-coordinate pen plotter”, to which we can also associate a knife with which, after tracing the ways for reconfiguration, we can cut the areas in which the packaging will fold.



### Implementation period

21.11.2017 – 31.12.2018

### Budget

46.500 RON (10000 EUR)

### Main activities

- Identifying the components needed to achieve the device, determining the best acquisition costs.
- Modular design of the devices provided in the project.
- Studying the variants developed for the purpose of choosing a first prototype variant of the device.
- Testing the obtained devices, determining the optimal working parameters.
- Identify, test and establish CAD/CAM/CAE modeling software that best fit in the packaging modeling phase for reconfiguration and reuse.
- Possibility to carry out practical activities with the devices designed and the possibility to develop related laboratory applications.

### Results

- Determining the optimal technical solution to meet the required requirements.
- Drawing up a list of the main components of the stand/device to reconfigure the packaging.
- Choosing the most advantageous offer.
- Determining a first virtual version of the work device, testing the device and choosing the type of packaging involved.
- Depending on the virtually developed solutions, choosing the best option.
- Testing the device with which we reconfigure the packaging, calibrating it to the optimal working parameters for the different packaging ranges under reconfiguration.
- Attempts to see the device's behavior at work, determine possible errors in operation, and determine how to correct them.
- Conceiving, structuring and drafting the technical documentation containing the working methodology of the devices proposed in the project.

### Applicability and transferability of the results:

Designing laboratory work related to disciplines in the Department of Mechatronics and Robotics. Preparation of laboratory work. Making a teaching material with the right steps in using and working with this device.

Developing and other applications that are suited to working with our stand equipment.

### Research team

Eugen S. ZĂBAVĂ, Project Director  
Hannelore FILIPESCU, Member  
Valentin CIUPE, Member

### Contact information

Assist. Prof. Eugen S. ZĂBAVĂ, PhD  
faculty of Mechanical Engineering  
Department of Mechatronics  
Address: Blvd. Mihai Viteazu, No.1 300222, Timisoara  
Phone: (+40) 256 403784  
Mobile: (+40) 767954223  
E-mail: eugen.zabava@upt.ro

## THE STUDY OF HAMILTON-POISSON SYSTEMS AND THEIR INTEGRABLE DEFORMATIONS USING THE ENERGY-CASIMIR MAPPING

### Goal of the project

1. The study of the Hamilton-Poisson systems by using the associated energy-Casimir mapping.
2. The study of changes in the behavior of dynamical systems by using some integrable deformations.

### Short description of the project

We study the connections between the dynamics of Hamilton-Poisson systems and the corresponding energy-Casimir mapping.

We also consider integrable deformations of known dynamical systems.

### Implementation period

21.11.2017 – 31.12.2018

### Budget

46.500 RON (10000 EUR)

### Main activities

- The study of some integrable deformations of relevant dynamical systems
- The study of the energy-Casimir mapping with polynomial and non-polynomial components
- The study of some general results of the integrable deformations of the three-dimensional Hamilton-Poisson systems
- The study of the connections between the partition of the image of the energy-Casimir mapping and types of orbits

### Results

- 2 papers published in ISI journals
1. "Integrable Deformations of Three-Dimensional Chaotic Systems", Lăzureanu, C., INTERNATIONAL JOURNAL OF BIFURCATION AND CHAOS, Volume: 28, Issue: 5, (2018)
  2. "Stability and Energy-Casimir Mapping for Integrable Deformations of the Kermack-McKendrick System", Lăzureanu, C., Petrișor, C., ADVANCES IN MATHEMATICAL PHYSICS, Volume 2018, (2018).

### Results

- 3 communications / submitted papers (ISI Conferences)
  1. "Stability and some special orbits for an integrable deformation of the Rikitake system", Lăzureanu, C., Hedrea, C., Petrișor, C., International Conference ICAMCS 2018, Paris, France.
  2. "On the integrable deformations of a system related to the motion of two vortices in an ideal incompressible fluid", Lăzureanu, C., Hedrea, C., Petrișor, C., International Conference ICCMAE 2018, Timișoara.
  3. "Chaotic Behavior of an Integrable Deformation of a Nonlinear Monetary System", autor: Lăzureanu, C., International Conference ICNAAM 2018, Rodos, Greece.
- 2 communications / submitted papers (BDI Conferences)
  1. "On a deformed version of the T system", autori: Lăzureanu, C., Căplescu, C., International Conference ICMA 2018, Timișoara.
  2. "On the dynamics of a Hamilton-Poisson system", Lăzureanu, C., Petrișor, C., International Conference ICMA 2018, Timișoara.

### Research team

Cristian-Virgil LĂZUREANU, Project Director  
Ciprian HEDREA, Member  
Camelia PETRIȘOR, Member

### Contact information

Assist. Prof. Cristian LĂZUREANU, PhD  
Department of Mathematics  
Address: Piata Victoriei 2, 300006, Timisoara  
Phone: (+40) 256 403099  
Mobile: (+40) 766682005  
E-mail: cristian.lazureanu@upt.ro

## RESEARCH AND EDUCATIONAL LABORATORY „LEAN AND SUSTAINABILITY”

### Goal of the project

Initiating an interdisciplinary educational and research laboratory called “Lean and Sustainability” by using and developing enterprise games that physically simulate an enterprise’s activities, focusing on lean and sustainability concepts.

### Short description of the project

Project target groups: students, teachers/researchers, companies, which may use improvement tools.



Enterprise games were purchased and a new game was created for educational and research purpose.



### Implementation period

21.11.2017 – 31.12.2018

### Budget

46.500 RON (10000 EUR)

### Main activities

- Dissemination and launching of the project workshops.
- Scientific research under the theme “Lean and Sustainability”.
- Creating the Lean and Sustainability Educational and Research Lab.
- Acquisition of enterprise games.
- Training the trainers for business games.
- Use of enterprise games in the laboratory for students.
- Creating a new game / tool that combines the advantages of the two concepts.
- Participating with scientific articles at prestigious international conferences.
- Publication of scientific articles in indexed WOS journals.
- Making materials for dissemination (flyers, posters, roll-ups, banner and web page).

### Results

- “Lean and Sustainability” Educational and Research Laboratory – M104 room, FMPT
- 2 dissemination workshops - project launch (Dec 2017) + project completion (Dec 2019)
- 2 purchased enterprise games in the theme of the proposed new lab
- New SLIM Game and SLIMx tool created
- 8 Instructors trained in the newly created business game
- Enterprise games played in the lab with students
- Materials made for dissemination (flyers, posters, roll-ups, banner, folders, notebooks, pens, web page)
- 6 project members’ participations in conferences (3 conferences, 2x project manager, 4x team members, 1 virtual presentation).
- 3 scientific papers published at conferences.
- 2 scientific articles in WOS journals (1 published, 1 in evaluation).

### Applicability and transferability of the results:

The project applicability are: in laboratory for training students to use lean and sustainability tools; in research in the interdisciplinary domain of the two concepts; in companies to use improvement tools. Teaching using enterprise games was a goal, physically simulating enterprise’s activities, with transferability of learning in laboratory as student to using at actual work place as employee.

### Research team

Ilie Mihai TĂUCEAN, Project Director  
Larisa IVAȘCU, Member  
Mircea NEGRUȚ, Member  
Șerban MICLEA, Member

### Contact information

Assoc. Prof. Ilie Mihai TAUCEAN, PhD  
Faculty of Management in Production and Transportation  
Department of Management  
Address: 14 Remus Str. 300191, Timisoara  
Phone: (+40) 256 404282  
Mobile: (+40) 744 703894  
E-mail: ilie.taucean@upt.ro  
Web: <http://mpt.upt.ro/cercetare/proiecte/proiect-leansuslab.html>

## A MULTILINGUAL EXPLANATORY DICTIONARY OF EDUCATIONAL TERMS (ROMANIAN, ENGLISH, GERMAN, FRENCH)

### Goal of the project

The main goal was to create a multilingual explanatory dictionary of educational terms which updated the list of educational terms, explained them in Romanian and equated them in English, German and French.

### Short description of the project

The main goal was to create a multilingual explanatory dictionary of educational terms which updated the list of educational terms, explained them in Romanian and equated them in English, German and French.



### Implementation period

21.11.2017 – 31.12.2018

### Budget

46.500 RON (10000 EUR)

### Main activities

- Identification of specialised texts available both in print and in electronic forms;
- Building a terminological corpus;
- Source-term extraction;
- Equating the Romanian terms in the other three languages;
- Accessing terminological databases to expand the terminological corpus;
- Alphabetic indexing of the Romanian terms;
- Definition and explanation of terms in Romanian;
- Checking dictionary content;
- Preparing the electronic version of the manuscript;
- Scientific reviewers' manuscript review;
- Publication of the dictionary.

### Results

- 2 scientific papers presented at 2 ISI conferences, in which the entire team participated, and published in the conference proceedings:
  - Proceedings of EDULEARN18 Conference
  - ICERI2018 Proceedings
- Submitting a study for publication in the ISI journal International Journal of Lexicography (authors: the entire team)
- Participation in an international prestigious conference, British and American Studies (BAS) 2018, of the project manager and a member of the research team, where a study made by the entire team was presented
- Publication of the dictionary
- Participation of the entire team, with 4 scientific papers, in the international conference Professional Communication and Translation Studies PCTS 11 (4-5 April 2019)
- Participation, with 2 scientific papers, of the project manager and a member of the research team in the international conference British and American Studies (BAS) 2019 (18-19 May 2019).

### Applicability and transferability of the results:

The dictionary enriches the terminological studies by updating the list of Romanian educational terms, by explaining them in Romanian, and by equating them in three other languages. In the context of the internationalization of education, the dictionary is a useful tool for anyone working in the educational field.

### Research team

Simona-Cristina ȘIMON, Project Director  
Anca-Mihaela DEJICA-CARTIȘ, Member  
Andrea KRISTON, Member  
Claudia-Elena STOIAN, Member

### Contact information

Assist. Prof. Simona-Cristina ȘIMON, PhD  
Faculty of Communication Sciences  
Department of Communication and Foreign Languages  
Address: Traian Lalescu Str., No. 2A, Postal Code 300223, Timișoara  
Phone: (+40) 256 404011  
Mobile: (+40) 724 75 47 88  
E-mail: simona.simon@upt.ro  
Web: <http://sc.upt.ro/ro>



# International Research Projects





## PROJECTS SUPPORTED BY INTERNATIONAL PUBLIC FUNDS IMPLEMENTED BY UPT 2018

Field	Total number of projects	Number of projects presented
Chemistry	1	1
Engineering science	15	6
Materials science	3	-
Mathematics	2	2
Social science	1	-
<b>Total</b>	<b>22</b>	<b>9</b>



## EVOLUTION OF PROJECTS SUPPORTED BY INTERNATIONAL PUBLIC FUNDS IMPLEMENTED BY UPT 2014 - 2018

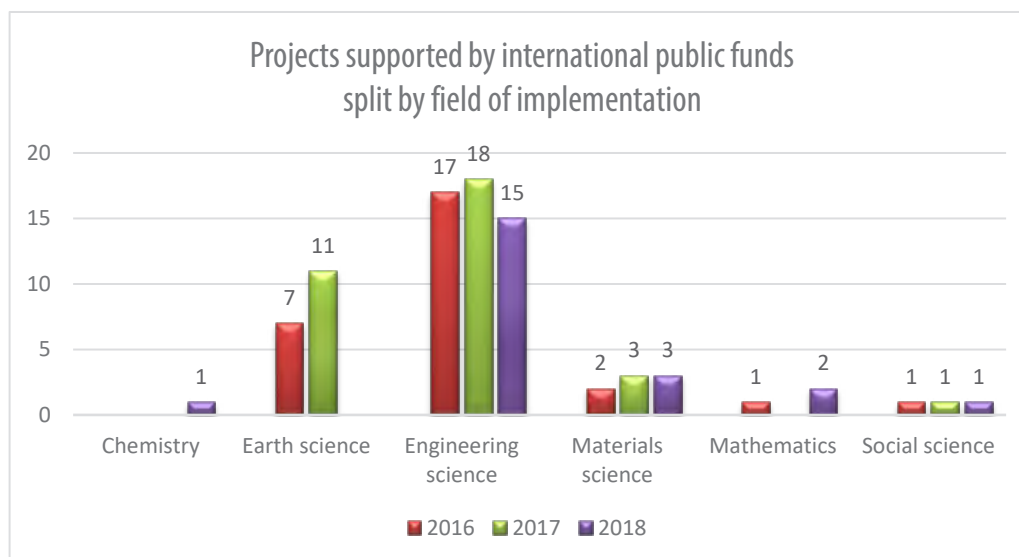
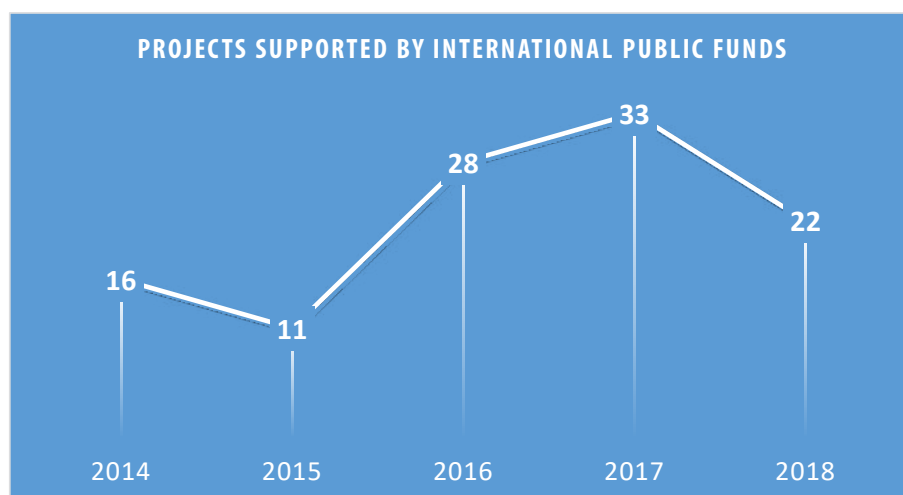



## VALORISATION OF KNOWLEDGE FOR EUROPEAN PRE-QUALIFIED STEEL JOINTS

### Goal of the project

Seismic prequalification criteria for certain steel joint typologies were developed during the previous RFCS project, EQUALJOINTS. The current project aims to valorize, disseminate and extend the prequalification criteria for practical applications to a wide audience by producing informative documents, design guidelines and organizing seminars and workshops.

### Short description of the project

The project aims the implementation of the prequalification criteria of the steel moment resisting beam-to-column joints in the future versions of design codes.

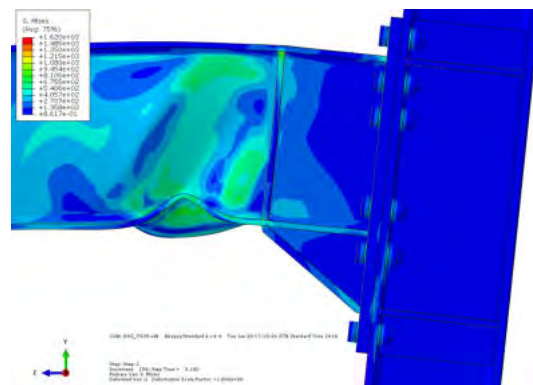
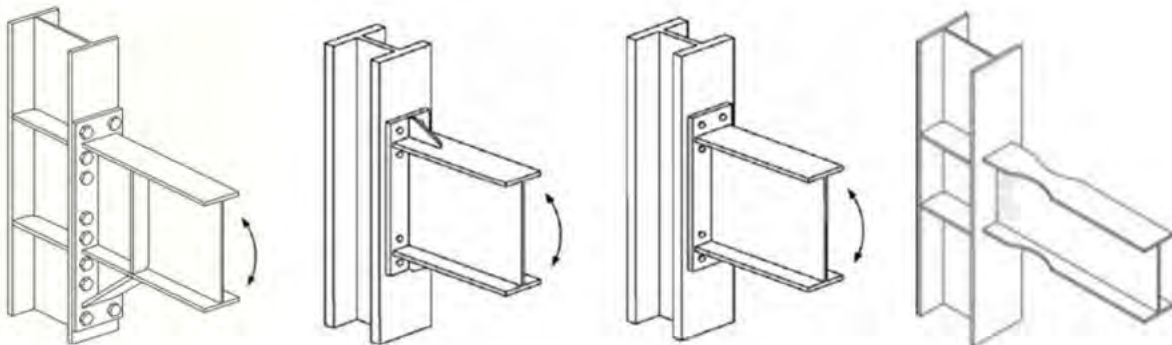

### Project implemented by

UNIVERSITA DEGLI STUDI DI NAPOLI FEDERICO II (UNINA)  
- coordinator  
ARCELORMITTAL BELVAL & DIFFERDANGE SA (AMBD)  
UNIVERSITE DE LIEGE (ULG)  
POLITEHNICA UNIVERSITY TIMIȘOARA (UPT)  
UNIVERSIDADE DE COIMBRA (UC)  
EUROPEAN CONVENTION FOR CONSTRUCTIONAL STEELWORK (ECCS)  
UNIVERSITA DEGLI STUDI DI SALERNO (UNISA)  
IMPERIAL COLLEGE OF SCIENCE TECHNOLOGY AND MEDICINE  
(Imperial)

Centre Technique Industriel de la Construction Metallique (CTICM)  
NATIONAL TECHNICAL UNIVERSITY OF ATHENS (NTUA)  
CESKE VYSOKÉ UCENI TECHNICKÉ V PRAZE (CVUT)  
TECHNISCHE UNIVERSITEIT DELFT (TU Delft)  
UNIVERZA V LJUBLJANI (UL)  
UNIVERSITET PO ARCHITEKTURA STROITELSTVO I GEODEZIJA (UASG)  
UNIVERSITAT POLITECNICA DE CATALUNYA (UPC)  
RHEINISCH-WESTFAELISCHE TECHNISCHE HOCHSCHULE AACHEN  
(RWTH AACHEN)

## Implementation period

01.07.2017 – 30.06.2019

## Main activities

- Development of informative documents for the 4 beam-to-column joints qualified within the EQUALJOINTS project and translation of these documents from English to 11 additional languages
- Development of recommendations and criteria to be used in setting up limits of applicability between EN 1993:1-8 and EN 1998-1. A set of requirements within EN 1090-2 are defined. The documents are drafted as pre-normative design recommendation in English which are translated 11 additional languages
- Development of guidelines for design and analysis of seismic resistant steel structures accounting for the behaviour of beam-to-column joints. In addition, examples for different structural systems are presented which show the influence of different joint typologies.
- Enhancement of the EQUALJOINTS Matlab software for analytical prediction of the cyclic response of joints, allowing an easy application by users in practice. Moreover, an EQUALJOINTS-app for mobile phone is developed.
- Preparation of the material to be disseminated in English and translation in the mother tongue of the places where seminars/workshop will be taken.
- Organization of workshops and seminars where the pre-normative design guidelines will be disseminated. In addition, the materials will be available in printed forms and downloadable from the project website.

## Results

The prequalification criteria for the 4 typologies of steel moment resisting beam-to-column joints from the EQUALJOINTS project (3 bolted connections and 1 reduced beam section – dog-bone) are being considered for the implementation in the next version of the design codes. The dissemination materials will be available in printed form and downloadable from the project website.

## Applicability and transferability of the results

- Use of the new versions of design codes with simplified procedures for designing steel moment resisting beam-to-column joints.
- The rotational capacity and ductility demand of the joints required by the current codes are assured using the prequalification seismic design criteria.
- Increased structural safety against the seismic hazard in large parts of Europe.
- Improvement in life cycle costs and sustainability due to the reduction of losses caused by seismic hazards.

## Financed through/by

Research Fund for Coal and Steel, grant agreement RFCS 12/04/2017 – number 754048

## Research Centre

The Research Centre for Mechanics of Materials and Structural Safety – CEMSIG

## Research Team

- Acad. Dan DUBINA, PhD
- Assoc.prof. Aurel STRATAN, PhD
- Eng. Dominiq JAKAB
- Assist. Adriana CHESOAN, PhD

## Contact information

Acad. Dan DUBINA  
Faculty of Civil Engineering  
Department of Steel Structures and Structural Mechanics,  
Ioan Curea Street No.1, 300224, Timișoara  
Phone: +40 (0) 256 403 911  
Mobile: +40 (0) 740 137 610  
E-mail: dan.dubina@upt.ro

## VALORISATION OF KNOWLEDGE FOR SUSTAINABLE STEEL-COMPOSITE BRIDGES IN BUILT ENVIRONMENT - SBRIPLUS

### Goal of the project

Within the RFCS project SBRI, a holistic approach to assess steel-composite bridges by combining Life Cycle Assessment (LCA), Life Cycle Costs (LCC) and Life Cycle Performance (LCP) was developed and applied to some representative bridges. This project aims at the valorisation, dissemination and extension of the developed method for advanced applications and further bridge types. To reach a wide audience among engineers and authorities, two Design Manuals and a software tool will be disseminated in the frame of several seminars across Europe.

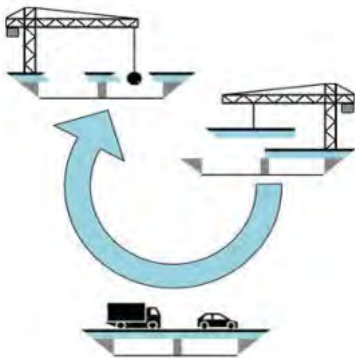

*Sketch of the life-cycle of a bridge*

### Short description of the project

The aim of SBRIplus project is to promote the developed knowledge and design methodologies by combining the LCA, LCC and LCP analyses along the entire life-cycle of bridges.

### Project implemented by

ArcelorMittal Belval & Differdange S.A., Luxembourg

### Implementation period

01.07.2016 – 31.06.2018

### Main activities

1. Explanation of methodology and background by elaboration of worked examples and improvement of the SBRI-tool;
2. Extension of bridge types by advanced application to innovative bridges across Europe demonstrating the flexibility and applicability of the methods developed;
3. Dissemination activities (11 European languages, organization of 13 workshops);
4. Providing of recommendations for advanced applications and guidelines for bridge authorities;
5. To provide recommendations summing up and concluding the analyses and being the bases for guidelines to be elaborated for bridge authorities.

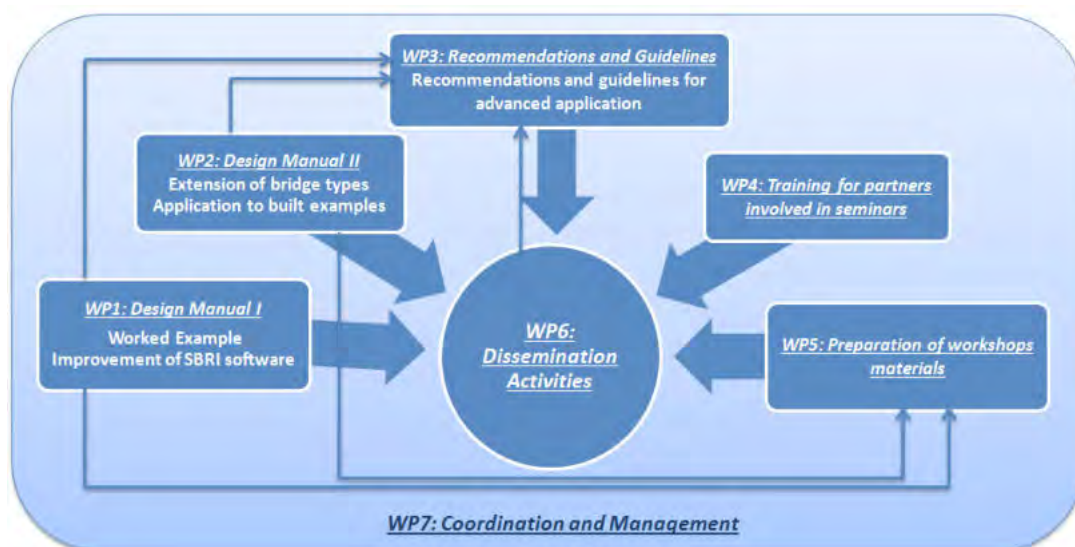

*The 7 Work Packages (WPs) of the SBRIplus project*

## Results

Two design manuals will be prepared and translated in 11 European languages and distributed within the planned dissemination activities. The first Design Manual includes background information on the methodology and worked examples for easy application with the help of the improved software tool. By analyses of built examples, the SBRI method will be applied to innovative bridge solutions, the results and the conclusions being shown in the second Design Manual.

The seminars around Europe will offer the opportunity to present not only the results of the SBRIplus project, but also the advanced application to innovative solutions in addition to national regulations and practice.



*The location of the seminars around Europe*

## Applicability and transferability of the results

As bridges are an integral part of the European-wide traffic infrastructure, being of vital importance for society, the amount of steel used in the construction of steel and steel-composite bridges represents an important market for the steel industry. The application of a sustainable life cycle design of bridges causes an increased steel consumption. As currently the decisive criteria at tender stage are the minimum construction costs, the needed and promoted shift to a sustainable life cycle decision making, brings the steel-composite bridges forward. The advantages of low environmental inputs, low life cycle costs and low user costs for the entire life cycle are combined in sustainable steel-composite structures. The major objective of the proposal is to valorize and transfer the knowledge gained in the SBRIplus project into practice and thus to make it available to a broad audience along engineers, authorities, bridge operators and designers.

## Financed through/by

Research Fund for Coal and Steel, grant agreement No 710068.

## Research Centre

Research Center for Mechanics of Materials and Structural Safety (CEMSIG), Politehnica University Timișoara  
Research Institute for Renewable Energy (ICER-TM), Politehnica University Timișoara

## Research Team

ArcelorMittal Belval & Differdange SA (Luxembourg);  
University of Stuttgart (Germany);  
University of Coimbra (Portugal);  
Aktien-Gesellschaft der Dillinger Hüttenwerke AG (Germany);  
Institut Francais des Sciences et Technologies des Transports, de l'Amenagement et des Reseaux (France);  
RAMBOLL Sverige AB (Sweden);  
BRISA Engenharia e Gestao SA (Portugal);  
FOSTA -Forschungsvereinigung Stahlanwendung e.V. (Germany);  
Politehnica University Timișoara (Romania);  
Ceske Vysoke Uceni Technike V Praze (Czech Republic);  
Fundacion Tecnalia Research & Innovation (Spain);  
University of Naples Federico II (Italy);  
ATKINS Consultants Limited (UK);  
Stichting Bouwen met Staal (Netherlands);  
BKE sp. z o.o. (Poland);  
Sveuciliste u Zagrebu Gradevinski Fakultet (Croatia);  
S. Stathopoulos - K. Farros Consulting Engineers (Greece).

## Contact information

Prof. Viorel UNGUREANU, PhD  
Faculty of Civil Engineering  
Department of Steel Structures and Structural Mechanics  
Address: Str. Ioan Curea, No. 1, 300224, Timișoara  
Phone: (+40) 256 403912  
Mobile: (+40) 740 137640  
E-mail: viorel.ungureanu@upt.ro  
Web: www.ct.upt.ro



## TEMPERATURE ASSESSMENT OF A VERTICAL MEMBER SUBJECTED TO LOCALISED FIRE - DISSEMINATION

### Goal of the project

LOCAFI+ represents the valorisation project of the RFCS project LOCAFI the main objective of which was to provide designers with scientific evidence that will allow them designing steel columns subjected to localised fires.

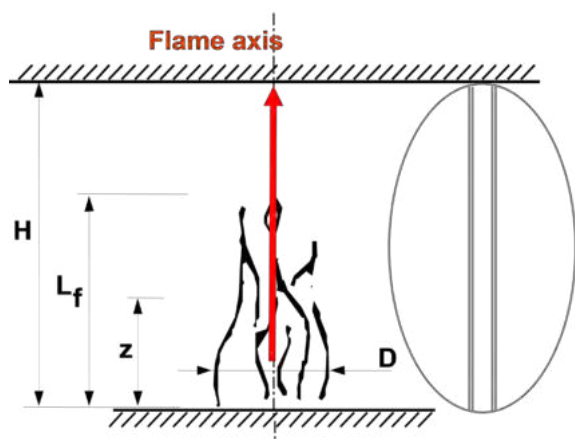
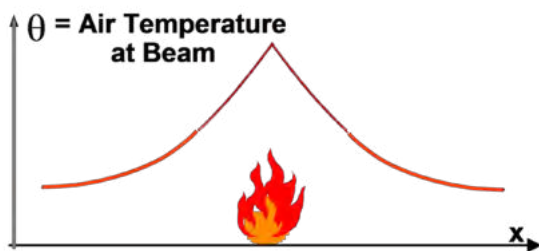
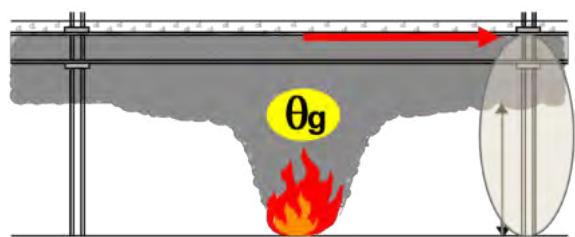

### Short description of the project

The project aims to disseminate the methodology for the fire design of columns under localised fire in several European countries, by means of national seminars.

### Project implemented by

ArcelorMittal Luxembourg (coordinator)

### Implementation period

1.07.2017-31.12.2018

### Main activities

- Development of nomograms for a wide range of different localised fires
- Development of the design guide for practitioners
- Preparation of the PowerPoint presentations for the workshops
- Adaptation of OZone software
- Translation activities and preparation of document with legal context and adapted design examples
- Preparation/ organization of the seminars
- Design of the Internet website with documents available online

### Results

An important number of seminars will be organised across Europe to present the simplified method developed within LocaFi project which will be implemented in the latest version of the European standard EN1991-1-2, its background (experimental tests, numerical investigations), user-friendly software and case studies.

### Applicability and transferability of the results

The analytical models developed within the LocaFi project were introduced in a user friendly software and in an advanced calculation model for fire design, in order to offer a large utilization of the procedure for the construction market.

## Financed through/by

EUROPEAN COMMISSION  
DIRECTORATE-GENERAL FOR RESEARCH AND INNOVATION  
Research Fund for Coal and Steel - RFCS

## Research Centre

The Research Center for Mechanics of Materials and Structural Safety  
- CEMSIG,  
Research Centre of Excellence of the Politehnica University Timișoara

## Research Team

Prof. Raul ZAHARIA (coordinator for Politehnica University Timișoara)  
Assist. Prof. Dan PINTEA, PhD  
Prof. Daniel GRECEA, PhD  
Assoc. Prof. Adrian DOGARIU, PhD  
Assist. Prof. Ioan BOTH, PhD

## Contact information

Professor Raul Zaharia  
Faculty of Civil Engineering  
Department of Steel Structures and Structural Mechanics  
Ioan Curea 1, Timisoara, ROMANIA  
Tel. +40/256403922  
e-mail: raul.zaharia@upt.ro

## PROVISIONS FOR GREATER REUSE OF STEEL STRUCTURES - PROGRESS

### Goal of the project

The PROGRESS project will provide methodologies, tools and recommendations on reusing steel-based components from existing and planned buildings. The project particularly targets the design for deconstruction and reuse of envelopes, load-bearing frames, trusses and secondary elements of single-storey buildings framed in steel. This building type has broad applicability as industrial, commercial, sports, exhibition, warehouse facilities, and shows most potential in suitability for reuse and viability for circular economy business models. The whole life benefits of reusable single-storey steel buildings will be quantified from environmental and economic viewpoints. The outcomes will be extensively disseminated in particular among manufacturers, designers, contractors and researchers.



### Short description of the project

The main objective of the proposal is to develop products, systems, methods and protocols that facilitate reuse of various components of steel-framed single-storey buildings. The proposed project addresses both deconstruction and reuse of existing buildings and how new buildings can be designed, constructed and documented to facilitate future reuse. Its scope includes: (a) primary structures (frames), (b) secondary structures, (c) envelope components and hybrid multi-material systems.

### Project implemented by

VTT Technical Research Centre of Finland Ltd., (VTT, Finland)

### Implementation period

01.07.2017-30.06.2020

### Main activities

- review of the experiences from the successful reuse and deconstruction projects collected by the project partners and from the practitioners in the building industry;

**Table 1. Reuse scenarios**

	In-situ	Same site		Different site	
		Same configuration	Different configuration	Same configuration	Different configuration
Entire primary structure	A	B	C	D	E
Elements of the primary structure	N/A	N/A	F	N/A	G
Individual elements	N/A	N/A	H	N/A	I

- propose methods for the assessment of suitability of materials and elements for the reuse, including recommendations for their modification/adaptation to fit in the new design;
- propose technical recommendations for the increase of reusability of the components to be provided on component and building design levels.
- propose novel hybrid solutions for envelopes of single-storey buildings, either new buildings or renovation projects, that improves the thermal performance of the entire building, service life of envelopes and reusability of solutions themselves;
- propose a methodology to quantify and declare the environmental benefits of reused elements, resulting in recommendations on the circularity and LCA methodology;
- provide benchmark for demolition, classification and testing/verification protocols developed on a real deconstructed building including the laboratory tests to identify mechanical and chemical properties of the materials;
- design case studies to cover the most common reuse situations.

## Results

The outcomes of the project will include recommendations to:

- Reduce the technical barriers to reuse through establishing the quality verification procedures for the structural elements and envelopes of deconstructed low-rise buildings to be reused;
- Simplify the implementation of reusable components through recommendations for design for deconstruction and reuse, and for design using reclaimed elements as well as for safe and efficient deconstruction activities;
- Support the product manufacturers', facility owners' and designers' decision making by recommended methodology to calculate the environmental impact and cost of steel components reusing;
- Develop an online reused steel trading portal to co-ordinate the supply and demand for reused steel-based components;
- Develop novel types of hybrid solutions for envelopes in order to improve the thermal performance of a building, extend the service life of an envelope and maximize the reuse potential of components.

## Applicability and transferability of the results

The majority of existing steel low-rise buildings can be deconstructed into elements such as cold-formed or hot-rolled sections, sheets, panels, frames or truss girders. These components have very high reuse potential, but require verification of the material quality, dimensions and tolerances in order to be included in new building projects. The future reuse of modern buildings, however, may be different, because those structures are increasingly designed as systems and their design information can be easily maintained for instance as a building information model (BIM).

## Financed through/by

Research Fund for Coal and Steel, EU, grant agreement No 747847.

## Research Centre

Research Center for Mechanics of Materials and Structural Safety (CEMSIG), Politehnica University Timișoara

## Contact information

Acad. Dan DUBINA, PhD  
 Faculty of Civil Engineering  
 Department of Steel Structures and Structural Mechanics  
 Phone: (+40) 256 403920  
 Mobile: (+40) 740 137610  
 E-mail: dan.dubina@upt.ro  
 Web: www.ct.upt.ro

Prof. Viorel UNGUREANU, PhD  
 Faculty of Civil Engineering  
 Department of Steel Structures and Structural Mechanics  
 Research Institute for Renewable Energy (ICER-TM)  
 Address: Str. Ioan Curea, No. 1, 300224, Timișoara  
 Phone: (+40) 256 403912  
 Mobile: (+40) 740 137640  
 E-mail: viorel.ungureanu@upt.ro  
 Web: www.ct.upt.ro

## NOVEL MODULAR STACK DESIGN FOR HIGH PRESSURE PEM WATER ELECTROLYZER TECHNOLOGY WITH WIDE OPERATION RANGE AND REDUCED COST (PRETZEL)

### Goal of the project

The overall objective of PRETZEL project is to develop an innovative polymer electrolyte membrane electrolyzer (PEMEL) that provides significant improvements in efficiency and operability to satisfy emerging market requirements. Such electrolyzers are urgently needed for the increased demands of the grid balancing services. In this context, PRETZEL is offering breakthrough technologies for becoming game changer in the field of water electrolyzers.

### Short description of the project

PRETZEL consortium will develop a 25 kW water electrolysis system based on a patented innovative cell concept, with a production capacity of 4.5 m<sup>3</sup> H<sub>2</sub> / h at rated power at a pressure of 100 bar and water temperature of 90°C.

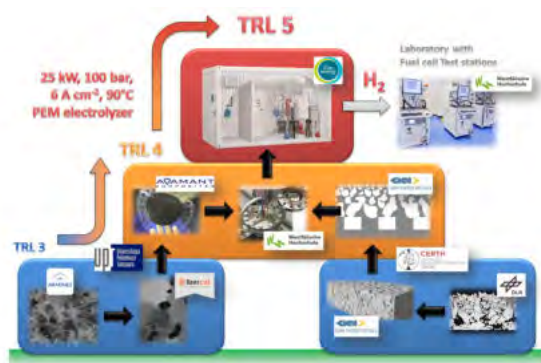

*Concept of PRETZEL project with component inputs and expected outcome.*

### Project implemented by:

#### Project Coordinator:

German Aerospace Center, Stuttgart, Germany (DLR)

#### EU Partners:

- Westphalian University of Applied Sciences, Germany (WHS)
- Association for Research and Development of Industrial Methods and Processes, France (ARMINES)
- Politehnica University Timișoara, Romania (UPT)
- Adamant Composites Ltd., Greece
- GKN Sinter Metals Engineering GmbH, Germany (GKN)
- Centre for Research and Technology Hellas, Greece (CERTH)
- Soluciones Catalíticas IBERCAT, Spain
- iGas energy GmbH, Germany



*“PRETZEL”-like shape passing over the geographical location of all PRETZEL partners representing the long-term collaboration in know-how, supply chain, business partnership and R&D.*

### Implementation period

01.01.2018 – 31.12.2020

### Main activities

1. Develop and manufacture the components of the PRETZEL for the innovative high pressure PEMEL that operates at increased temperatures.
2. Develop and manufacture the PRETZEL high pressure PEMEL stack based on the novel principle of hydraulic compression.
3. Set-up and undertake continuous procedures to evaluate the development process through all phases against PRETZEL specifications.
4. Integrate the innovative PEMEL stack into a high pressure PEMEL test facility and validate the overall performance and operational criteria.
5. Disseminate and exploit the innovations in PRETZEL in order to prepare the market penetration of the new technology.

## Results

- **Corrosion tests** on vacuum plasma sprayed Nb coatings on copper plates

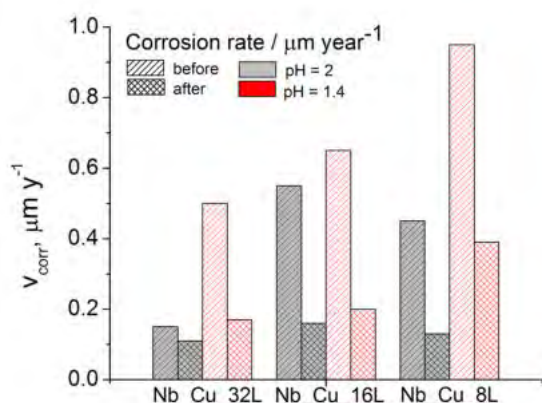
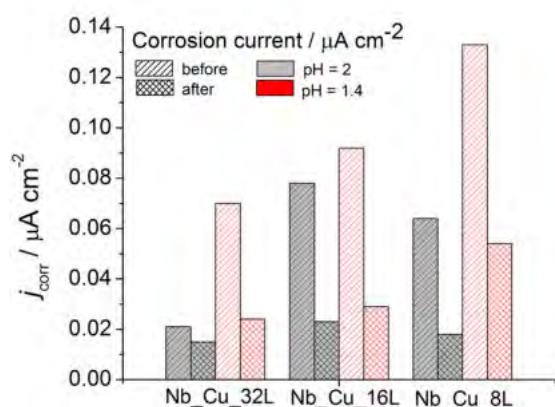

Comparison of corrosion currents and corrosion rates at pH = 2 and pH = 1.4, before and after stress test at 2 V for 6 h.

- **Physical characterization** of vacuum plasma sprayed Nb coatings on copper plates

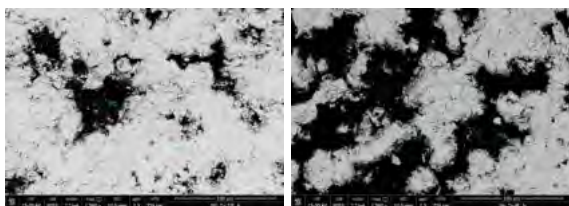

FE-SEM images of Nb\_Cu\_32L and Nb\_Cu\_8L after corrosion test in  $0.05 \text{ M H}_2\text{SO}_4 + 0.1 \text{ ppm F}^-$  (pH = 1.4)

## Applicability and transferability of the results:

- **System:** Development and validation of a 25 kW PEM electrolyzer system with hydrogen output pressure of 100 bars or higher. The high pressure will allow reducing costly and ineffective mechanical compression stages.
- **Cell components:** Reduction of critical raw materials such as Ir by the use of new aerogel supports, which allow reducing more than 70 % of the current precious metal loading compared to the state-of-the-art.

## Financed through/by

Fuel Cell and Hydrogen 2 Joint Undertaking under the European Union's Horizon 2020 research and innovation programme under grant agreement No 779478.

## Research Centre

Research Institute for Renewable Energy (ICER-TM), UPT

## Research team

Assoc. Prof. Andrea KELLENBERGER, PhD  
 Prof. Nicolae VASZILCSIN, PhD  
 Assoc. Prof. Narcis DUTEANU, PhD  
 Assist. Prof. Mircea Laurentiu DAN, PhD  
 Prof. Adina NEGREA, PhD  
 M.Sc.Eng. Delia DUCA,  
 Eng. Anuta SERAC

## Contact information

Prof. Andrea KELLENBERGER, PhD  
 Faculty of Industrial Chemistry and Environmental Engineering  
 Department of Applied Chemistry and Engineering of Inorganic Compounds and Environment  
 Bd. V. Parvan, No. 6, 300223, Timisoara  
 Phone: (+40) 256 404 178  
 Mobile: (+40) 726 448 966  
 E-mail: andrea.kellenberger@upt.ro  
 Web: <http://pretzel-electrolyzer.eu/>

## STUDY FOR A MONITORING STATION FOR EGNOS TO SUPPORT SERVICES IN EASTERN EUROPE

### Goal of the project

The objective of the study is the automatic reporting of EGNOS performance over Romania as well as the assessment of corrections transmitted by other SBAS.

### Short description of the project

Due to its geographical location, Romania is an ideal candidate for system performance monitoring at the border of EGNOS service area. Receivers placed in most parts of Romania will be able to track, in addition to EGNOS, also the Russian Federation's System for Differential Corrections and Monitoring (SDCM) and India's GPS Aided GEO Augmented Navigation system (GAGAN). UPT implemented within ESA regulatory framework and based on ECSS standards, all activities related to: an automatic reporting of EGNOS performance over Romania and assessment of other SBAS visible from Romania.



EGNOS Ranging and Integrity Monitoring Stations (RIMS) Sites

### Project implemented by

UPT as contractor and Thales-Alenia Space France, Pildo Labs Spain as subcontractors

### Implementation period

Sep 19 2016 – Mar 19 2018; 1 year of warranty after end of contract

### Main activities

- Management;
- Site Ranking;
- Site Selection;
- Deployment;
- Automatic Reporting & Performance Comparison;
- Communication

### Results

UPT deployed a monitoring site network, in Timișoara, Cluj-Napoca and Iasi, for the EGNOS service and all GNSS systems within Romania and archived the data for remote access by the Agency.

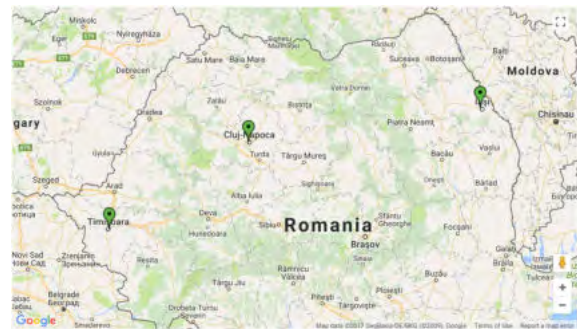

The three stations deployed at UPT-Timisoara, UTCN-Cluj and TUIASI-Iasi.

The respective locations were chosen at technical universities (UTCN and TUIASI), with whom UPT has signed hosting agreements. The user performances are monitored using the owl, a cloud service offered by Pildo Labs. The data is collected by PildoBoxes.



The antenna deployed at UPT.

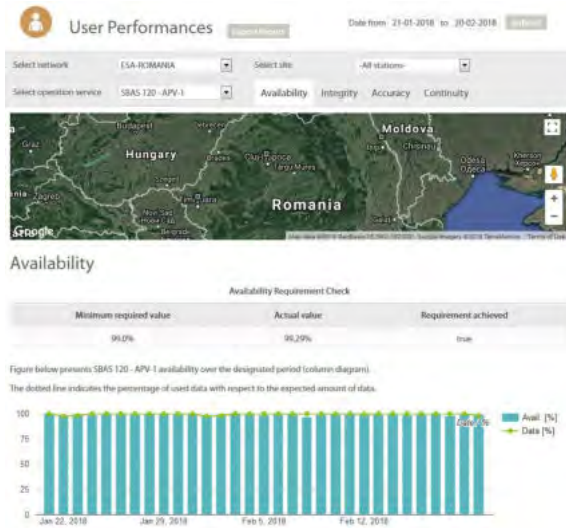

User Performances monitored using the owl cloud service: availability (SBAS 120- APV 1). This is the probability of the system being available for any given user at any given time.

### Stanford Plot Horizontal

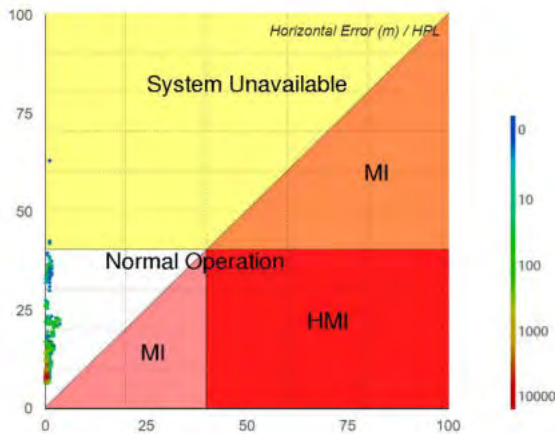

Integrity Stanford plot for UPT station (SBAS 120 – APV 1). Integrity is the system's ability to provide warnings to the user when the system is not available for a specific operation.

Deliverables: Site Selection Justification Document, Volume Simulation Plan, Service Volume Simulation Report, Hardware Deployment Plan, Hardware Deployment Report, Project Management Plan, Executive Summary Report, Financial Report, Final Report, Contract Closure Summary.

### Applicability and transferability of the results

The subject was evaluated at the start at technology maturity level 1 (Scientific Research) and is aimed to conclude the project at technology readiness level (TRL) 6: Model demonstrating the critical functions of the element in a relevant environment.

### Financed through/by

European Space Agency (ESA), contract number No. 4000 117 527 / 16/NL/CBi – UPT: 115.000 EURO, Thales Alenia: 15.000 EURO, Pildo Labs: 20.000 EURO

### Research centre

Intelligent Signal Processing Research Centre (ISPRC)

### Research team

Prof. Corina NAFORNIȚĂ (Technical Manager);  
 Prof. Andrei CĂMPEANU (Contracts Officer);  
 Prof. Ioan NAFORNIȚĂ, PhD  
 Prof. Alexandru ISAR, PhD  
 Prof. Marius OTEȘTEANU, PhD

### Contact information

Prof. Corina NAFORNITA, PhD  
 Faculty of Electronics, Telecommunications and Information Technologies  
 Department of Communications  
 Address: 2 Bd. V. Pârvan, 300223, Timișoara  
 Phone: (+40) 256 403318  
 Mobile: (+40) 722 782 359  
 E-mail: corina.naforrita@upt.ro  
 Web: <http://www.tc.etc.upt.ro/isprc/>



## REDOUBT - RELIABLE FPGA DATAPATH DESIGN USING CONTROL TECHNIQUES, CONTRACT ESA - 4000123993/18/NL/CRS

### Goal of the project

This project proposes a novel control theory inspired fault tolerant methodology for FPGA implementations of processing data-paths working in harsh radiation space environments. The proposed methodology will rely on adding control loops, which will detect and correct the radiation induced faults. We will consider the data-path processing component as a process, for which control components will be added in order to increase the fault tolerance.

The main objectives of this project are:

1. Development of the theoretical background for the control engineering inspired fault tolerant mechanism
2. FPGA implementation for the fault tolerant data-path with control feedback loops
3. Analysis of the proposed methodology in terms of cost and fault tolerance, and comparison with other approaches, such as triple modular redundancy (TMR), reduced precision replicas (RPR), or redundant residue number systems (RRNS).

The proposed technique will target arithmetic dominant applications, which include digital signal processing, robotic arm control, or graphic processing.

### Short description of the project

We aim at providing a novel fault tolerant technique for FPGA based digital electronics used in space applications.

### Project implemented by

Politehnica University Timișoara (UPT) -lead,  
Universitatea Tehnică din Cluj-Napoca (UTCN)- project partner.

### Implementation period

July 2018 - June 2019

### Main activities

We will investigate the cost and fault tolerance characteristics of the proposed technique, determining the advantages and the pitfalls. Thus, we will provide the theoretical foundation, a proof-of-concept implementation, as well as guidelines and characteristics for the control based reliability enhancement technique.

The project requires the following four steps:

1. SFI for the target datapath circuit in order to characterize the fault behaviour - This step will require RTL model of the targeted arithmetic intensive circuit, as well as performing the SFI at RTL for the implemented circuit.
2. Analytical modelling for the faulty datapath circuits - This step involves determining the high level modelling of faults, and developing the model associated to the process with perturbations. This step will consist of Matlab simulations.
3. Theoretical controller design used for error correction - In this step, the feedback controller will be designed in order to attenuate and mitigate the perturbations within the process associated to the faulty arithmetic datapath. The controller will be developed in Matlab
4. FPGA implementation and SFI based validation - This step will comprise of the RTL model of the control enhanced fault tolerant circuit, and its evaluation in terms of cost (FPGA implementation cost) and fault tolerance (using SFI). Comparisons with TMR, RRNS and RPR will be performed.

## Results

The following results are available so far:

1. Control engineering model using Matlab language for the circuit with specific design elements: pipeline, serial processing, adders, multipliers, multiplexors and multiply-add elements.
2. Matlab-Mpdelsim automated framework for co-simulation and fault injection.
3. Fault behavior characterization of the baseline circuit.

The following results are in progress:

1. Controller design for enhancing the fault tolerance of the baseline circuit subjected to SEU.
2. Evaluation of the advantages and limitations of this approach from both the reliability perspective and the cost efficiency perspective.

## Applicability and transferability of the results

The REDOUBT project is ongoing work. The results of the project have a high degree of innovation potential.

## Financed through/by

Agenția Spațială Europeană (European Space Agency – ESA)

## Research centre

Research Centre for Computers and Information Technology

## Research team

Oana BONCALO (PI)

Alexandru AMARICAL

Zsofia LENDEK (PI)

## Contact information

Assoc. Prof. Oana BONCALO, PhD  
Faculty of Automation and Computers  
Department of Computer Science  
Address: Vasile Pravan Blvd, No. 2, Room B522.  
Phone: (+40) 256 403 264  
E-mail: oana.boncalo@cs.upt.ro,  
oana.boncalo@gmail.com

## LINKING TRANSNATIONAL, MULTIMODAL TRAVELLER INFORMATION AND JOURNEY PLANNERS FOR ENVIRONMENTALLY-FRIENDLY MOBILITY IN THE DANUBE REGION

### Goal of the project

There is a huge cross-border travel demand within the EU leading to hundred millions of cross-border trips every year by EU residents and further several hundred million trips by international tourists. More than 100 providers of traveller information services exist in Europe covering different levels, from local to regional, national and pan-European. The goal is to work on the inter-linking of existing services in order to enable transnational journey planning that goes beyond the territory covered by the single systems and offers travellers one seamless journey planning result.

### Short description of the project

The objective is to develop a decentralised system architecture that enables distributed journey planning.

### Project implemented by

An international consortium of journey planner- and transport operators in the frame of the INTERREG project "LinkingDanube" from Austria, Czech Republic, Hungary, Slovakia, Slovenia and Romania (with two partners, UPT and Electronic Solutions Ltd.)

### Implementation period

01.01.2017 – 30.06.2019

### Main activities

In particular the main objective is to develop a decentralised system architecture that enables distributed journey planning. By developing and establishing a common interface at each of the involved systems, the exchange of requests and results (not data) will be facilitated. The multiple responses of the involved systems have to be merged by means of an intelligent journey planner algorithm. The involved systems will engineer an application programming interface (open API) that allows bi-directional communication of the enquirer system (the system requesting information from other systems) and the responding systems. A common exchange specification will be developed that all participating systems will implement. Besides the method of implementing common gazetteers and exchange points within the distributed system will be one of the crucial points.

### Results

The actual development work of LinkingDanube will be done both on national level in a decentralised adaption of the national journey planners as well as on central level in setting up a central entity. In the end this means that national services will be able to "plug into" a common interface and provide seamless information from multiple

systems to cross-border travellers. After implementation and testing, the technical feasibility will be demonstrated for the respective regions in relevant use cases.

The pilot action will demonstrate, test and validate the developed concept and demonstrate how integrated journey planning helps to connect citizens and commuters across borders and rural regions to major hubs. In this way the demonstrations will be the basis for further large-scale implementation.

### Applicability and transferability of the results:

A central focus of LinkingDanube is the development of a concept for transnational multimodal journey planners in order to integrate the advantages of hub-to-hub-routing with local routing for cross-border regions and the elaboration of technical specifications for interface and data exchange. This concept shall build on existing structures in the partner countries, enhancing existing journey planners instead of creating a completely new structure and is completely transferable.

### Financed through/by

Co-funded by the European Union through the Joint Secretariat of the Danube Transnational Programme

### Research team

Assoc. Prof. Dumitru IANCULUI, PhD  
Assist. Prof. Attila GÖNCZI, PhD  
Assist. Prof. Sorin NANU, PhD  
Assist. Prof. Octavian STEFAN, PhD.

### Contact information

Assoc. Prof. Dumitru IANCULUI, PhD  
Faculty of Mechanical Engineering  
Department of Mechanical Machines, Equipment and Transportation  
Address: Bv. Mihai Viteazu No.1, 300222, Timișoara  
Phone: (+40) 256 404 294  
Mobile: 0744 780 588  
E-mail: dumitru.iancului@upt.ro  
Web: <http://www.mec.upt.ro>

## CONTRIBUTIONS TO CODIMENSION $k$ BIFURCATIONS IN DYNAMICAL SYSTEMS THEORY

### Goal of the project

The overall project objectives are to produce new knowledge in the area of codim  $k$  bifurcations for continuous and discrete (smooth and non-smooth) dynamical systems and provide training in this area of research to early stage researchers.

### Short description of the project

The project achieves its objectives during secondments.

### Project implemented by

1. Politehnica University Timișoara (Coordinator)
2. Autònoma University of Barcelona
3. Obuda University
4. West University of Timisoara
5. University of Craiova
6. Acmit GmbH, Austria
7. University North Caroline at Charlotte
8. Shanghai Jiao Tong University, China
9. University of Sao Paulo, Brazil

### Implementation period

1 April 2018 - 31 March 2022

### Main activities

1. Study degenerate Bautin bifurcations;
2. Study degenerate Hopf-Hopf bifurcations;
3. Study other codimension  $k$  bifurcations in continuous (smooth) systems;
4. Study other codimension  $k$  bifurcations in discrete (smooth) systems;
5. Study codim  $k$  bifurcations in non-smooth systems;
6. Study bifurcations in non-smooth systems with impacts.

### Results

#### Published articles:

1. J. Llibre, C. Valls, C. Vidal, Global dynamics of the Buckingham's two-body problem, *ASS*, (2018), 363:255.
2. S. Li, J. Llibre, Phase portraits of continuous piecewise linear Liénard, *CSF*, 120 (2019), 149–157.
3. C. Rocsoreanu, M. Sterpu, Approximations of the heteroclinic orbits near a double-zero bifurcation with symmetry of order two (in press).

### Applicability and transferability of the results

Not applicable

### Financed through/by

Horizon2020-2017-RISE-777911, "Dynamics"

### Research team

J. Llibre,  
J. Torregrosa,  
G. Tigan,  
L. Kovacs,  
T. Haidegger,  
S. Mihalas,  
D. Constantinescu,  
S. Douglas,  
R. Oliveira,  
X. Zhang

### Contact information

Assoc. Prof. Gheorghe TIGAN, PhD  
Department of Mathematics,  
Address: Pta Victoriei, No.2, 300006, Timisoara  
Phone: (+40) 256 403098  
E-mail: gheorghe.tigan@upt.ro  
<http://www.gsd.uab.cat/dynamicsh2020>

# PROJECTS SUPPORTED BY PRIVATE FUNDS



## PROJECTS SUPPORTED BY PRIVATE FUNDS CONTRACTED BY UPT 2018

Field	Total number of projects	Number of projects presented
Environment	41	3
Exploration and exploitation of the earth	1	-
Transport, telecommunications and other infrastructures	17*	1
Education	2	-
Energy	2	1
Industrial production and technology	58**	10***
Technological and engineering sciences	3	-
<b>Total</b>	<b>124</b>	<b>15</b>

\* *National Private Funds: 16 projects;*  
*International Private Funds: 1 project.*

\*\* *National Private Funds: 57 projects;*  
*International Private Funds: 1 project.*

\*\*\* *National Private Funds: 9 projects;*  
*International Private Funds: 1 project.*





## EVOLUTION OF PROJECTS SUPPORTED BY PRIVATE FUNDS CONTRACTED BY UPT 2014 - 2018

A series of inter-institutional collaborations have crucially influenced UPT's ranking classification exercise between 2014 and 2018.

Two main categories of institutional collaborations are to be noted: inter-university collaborations and collaborations with enterprises. Each of them has clearly established, mutually-shared objectives: mutual support, know-how transfer, and cooperation objectives for a common output.

UPT has always maintained a close relationship with the community, with the external environment, this relationship being its own reason to exist. Beyond the actual research and formal education, the research accomplished through technological transfer has been a constant concern for the University departments, faculties and management structures, which is reflected in the number of contracts with private companies.

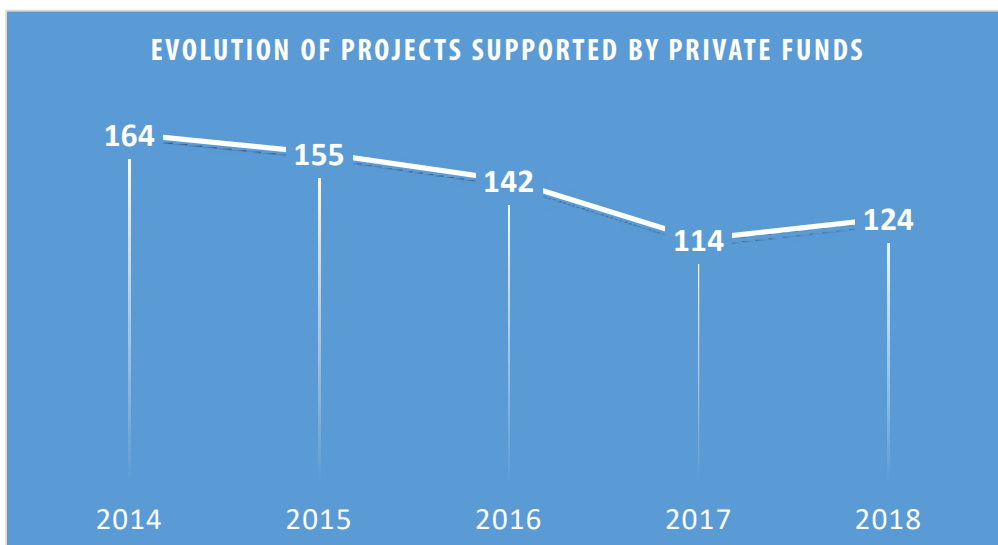

This chapter presents a selection of the research contracts with third parties.



## CONSULTANCY IN THE FIELD OF INDUSTRIAL TESTING SYSTEMS USING LABVIEW, LABWINDOWS/CVI AND NI TESTSTAND

### Goal of the project

The goal of the project is to develop industrial testing systems using LabVIEW, LabWindows/CVI and NI TestStand.

Industrial testing systems can help to ease testing process and can speed up testing in the industry. The implemented testing systems were mostly functional testers of circuits, but there were also implemented ICT testers too. The goal was to make better and more optimal testers.

### Short description of the project

The project included the creation of functional and ICT testers. The testers needed operator graphical user interfaces too (GUIs), which were implemented in LabVIEW and/or LabWindows/CVI. The test sequences were placed in NI TestStand and were ran using this environment.

### Implementation period

01/04/2018 – 01/04/2018

### Main activities

Applications development basics

- Simple applications:
  - Matrix Applications
  - Strings manipulation
  - File Handling
- The principles of programming events
- Error handling
- Creating user interfaces
- Using DAQmx Acquisition Cards
- Implementing data acquisition programs
- Communication Interfaces:
  - Serial Port (RS-232)
  - Parallel Port
  - GPIB (IEEE-488)
  - USB
  - Ethernet
- Interfacing Programmable Instruments

### Results

During the project there were implemented more GUIs for different test equipment's. Some GUIs were made in LabVIEW others in LabWindows/CVI.

There were implemented some data acquisition programs. Also, there were made systems which could log measurement data in text files. There were implemented more test cases and more tests which were loaded in NI TestStand sequencer, this way easing the industrial testing.

### Applicability and transferability of the results

- The project can be implemented in many industrial test applications. The created GUIs in LabVIEW and LabWindows/CVI can be reused and extended and transferred to test other electrical parameters from other circuit boards for other systems.
- With this knowhow the measurement of electrical parameters can be speeded up to increase production volumes.
- GUIs in LabVIEW and LabWindows/CVI were implemented, also data acquisition programs in LabVIEW were implemented in the Honeywell Life Safety Romania S.R.L. plant and also test cases for NI TestStand were developed.

### Financed through/by

Honeywell Life Safety Romania S.R.L.

### Research team

Prof. Mihaela Lascu, PhD  
Roland SZABO, PhD

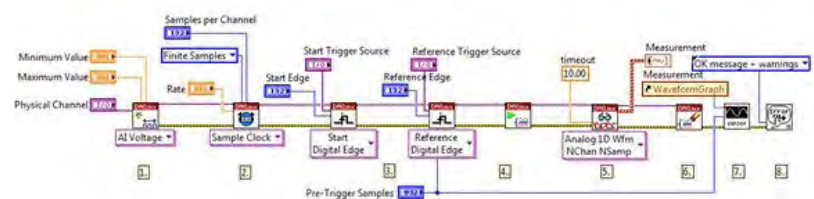

Data acquisition in LabVIEW

### Contact information

Prof. Mihaela Lascu, PhD  
Faculty of Faculty of Electronics, Telecommunications and Information Technology  
Department of Measurements and Optical Electronics  
Address: Vasile Parvan Av., No. 2 Postal Code 300223, Timisoara  
Phone: (+40) 256 403 366  
Mobile: 0729 783 787  
E-mail: mihaela.lascu@upt.ro, roland.szabo@upt.ro  
Web: <http://www.meo.etc.upt.ro/colectiv/titulari/2-uncategorised/2108-mihaela-ruxandra-lascu>

## RESEARCH ON ADVANCED INTEGRATION BETWEEN THE TERADYNE TSA N129 TEST STATION AND THE VECTOR CANCase XL DEVICE

### Goal of the project

The goal of this project was to implement a functional technical approach related to an integration between the Vector CAN Case XL (CCXL) module and the Teradyne In Circuit Tester (ICT). The proposed application is the achievement of a collaboration between two industrial partners: Continental Automotive Romania (Timișoara Plant) and Alfa Test S.R.L. The need for such an integration has originated in the context of permanent focus on innovative production solutions.

### Short description of the project

The capabilities offered by this solution include: communication protocol administration, automated formatting of CAN messages, CAN segmentation, selection information embedded in exchanged frames or the combination of ICT based measurements interposed between CAN dialogs.

### Implementation period

01.04.2018 - 31.03.2019

### Main activities

- Activity 1: A study on the communication possibilities between the Teradyne In Circuit Tester equipment and external hardware tools, using dedicated DLL files.
- Activity 2: Preliminary communication implementations between the Teradyne In Circuit Tester equipment and external hardware tools, using dedicated DLL files.
- Activity 3: Testing the communication library and extending the available commands set. The results should be a 90% minimal success rate for transferring the CAN frames between the Vector tools and the ICT software.

- The Teradyne Test Station Multi Site (1)
- Two CCXL network interfaces have been placed inside the back chassis; Test Fixture (2);
- DUTs (3);
- ICT monitors (4).



### Financed through/by

S.C. Alfa Test S.R.L., Timișoara

### Results

- over 130 CAN telegrams/responses and can be used for testing other products;
- average response time of 0.56s/CAN command (TS send cmd, TS receive rsp);
- Automated repetition in case of FAIL responses (3 times);
- First Pass Yield (FPY) = 98%, 51 consecutive runs, average test time is 97 s, over 320 CAN command/response exchanges for each test, experimental context;
- approximately 25000 DUTs/month tested with this solution;
- best FPY average over 2 months 96%, worst case FPY average over 2 months 79%. These results are a combined result, with pure ICT test;
- average test time/DUT is 107s.

### Applicability and transferability of the results

The solution is running in production, it includes over 100 CAN telegrams/responses and can be used for testing other products. An average response time for a single CAN telegram, from the moment it is issued by the Teradyne Test Station until the user receives the result on the Test Station interface is approximately 0.56 s. A 2.22 s execution time has been obtained for a frequency measurement test which includes 3 type of CAN telegrams.

The proposed application has been developed in the context of creating innovative test solutions which correspond to the requirements of one of the most important automotive companies worldwide.

### Research team

Assist. Prof. Raul Ciprian IONEL, PhD  
Assist. Prof. Liliana MĂȚIU-IOVA, PhD

### Contact information

Assist. Prof. Raul Ciprian IONEL, PhD  
Faculty of Electronics, Telecommunications and Informational Technologies, Department of Measurements and Optical Electronics  
Address: Room B326, 3rd Floor, Bd. Vasile Parvan, nr. 2, 300223 Timisoara, Romania  
Phone: (+40) 256403366, Mobile: (+40) 723619912  
E-mail: raul.ionel@upt.ro  
Web: <https://ieeexplore.ieee.org/document/8583920>

## EXPERIMENTAL TESTS ON STEEL JOINTS SUBJECTED TO BENDING

### Goal of the project

The project goal was to characterize experimentally the response of in-line connections between rectangular hollow sections which are able to transmit bending moment. The particularity of the joint consist of the limited dimensions to the RHS section for a discrete appearance.

### Short description of the project

Due to the multiple parts involved in the connection, the project focused on the failure mode and failure sequence of the connection components. The experimental work used a 500kN actuator, linear variable displacement transducers and a digital image correlation system to record the data necessary for the response curve of the joint.

### Implementation period

January – April 2018

### Main activities

The main activity of the project was related to the goal of the project i.e. monitoring the force vs deformation of the assembly by testing two specimens for the welded connection between the RHS and the end plate and two specimens for the bolted connection for the continuity of the elements.

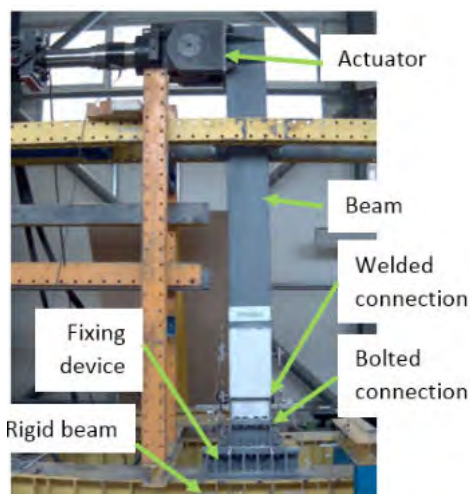

Fig. 1 Test setup for the bolted connection assembly  
Beside the connection, tensile tests were performed on standard specimens from the base material of the components.

### Results

The tests highlighted the deficiencies of the welding and the deformation and bearing capacity of the joint.

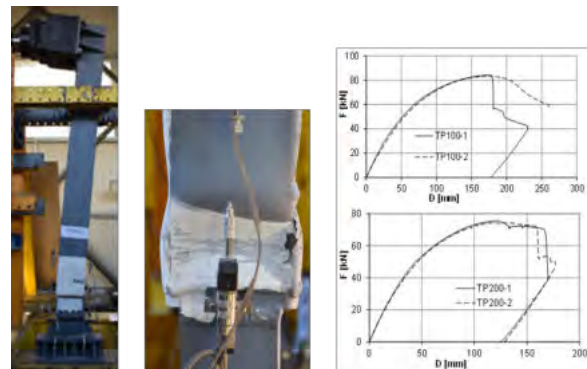

Fig. 2 The deformed shape and the response curve of joints

### Financed through/by

AFI PALACE BRASOV S.R.L.

### Research Centre

The Research Centre for Mechanics of Materials and Structural Safety  
– CEMSIG

### Research team

Assist. Prof Ioan BOTH, PhD  
Associate Prof. Aurel STRATAN, PhD  
Assist. Prof. Calin NEAGU, PhD  
Eng. Ovidiu ABRUDAN  
Technician Milenco UNG

### Contact information

Assist. Prof Ioan BOTH, PhD  
Faculty of Civil Engineering  
Department of Steel Structures and Structural Mechanics  
Address: Str. Ioan Curea, No. 1, 300226, Timisoara  
Phone: (+40) 256 4039 13  
Mobile: (+40) 727 8826 21  
E-mail: ioan.both@upt.ro

## EXPERIMENTAL TESTS ON MECHANICALLY COUPLED ARMATURES

### Goal of the project

The goal of the project is to see whether the rebar mechanical connections that SKANSKA company have provided fulfil the necessary requirements given in SR ISO 15835-1:2016.

### Short description of the project

In this project have been done tensile and cyclic test on rebars that have mechanical connections.

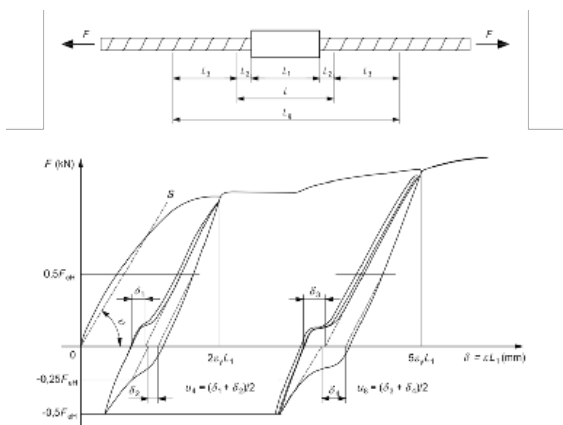

### Results

Most of the rebar mechanical connections fulfil the requirements given in specific code.

Denumire epruvete	Sarja cupla FORTEC	$u_4$ mm	$u_6$ mm	$R_m$ MPa	Localizare cedare
C32-1	7693	0.0497	0.0696	671	În bară, în afara lungimii îmbinării mecanice, L
C32-2		0.0435	0.0572	673	În bară, în afara lungimii îmbinării mecanice, L
C32-3		0.0423	0.0597	671	În bară, în afara lungimii îmbinării mecanice, L
C25-1	7414	0.0269	0.0403	595	În bară, în afara lungimii îmbinării mecanice, L
C25-2		0.0252	0.0407	610	În bară, în afara lungimii îmbinării mecanice, L
C25-3		0.0185	0.0286	597	În bară, în afara lungimii îmbinării mecanice, L
C32-25-1	1728	0.0042	0.0169	609	În bară, în afara lungimii îmbinării mecanice, L
C32-25-2		0.0507	0.0719	603	În bară, în afara lungimii îmbinării mecanice, L
C32-25-3		0.0423	0.0592	604	În bară, în afara lungimii îmbinării mecanice, L
C40-32-1	7744	0.1648	0.1632	670	În bară, în afara lungimii îmbinării mecanice, L
C40-32-2		0.1539	0.1616	671	În bară, în afara lungimii îmbinării mecanice, L
C40-32-3		0.1399	0.1570	675	În bară, în afara lungimii îmbinării mecanice, L
C32-1	7693	0.040	0.070	623	În bară, pe lungimea L2
C32-2		0.035	0.071	668	În bară, în afara lungimii îmbinării mecanice, L
C32-3		0.029	0.053	675	În bară, pe lungimea L2
C25-1	7414	0.0185	0.0269	600	În bară, în afara lungimii îmbinării mecanice, L
C25-2		0.0235	0.0336	550	În bară, în afara lungimii îmbinării mecanice, L
C25-3		0.0151	0.0245	599	În bară, în afara lungimii îmbinării mecanice, L
C20-1	8114	0.0018	0.0219	596	În bară, în afara lungimii îmbinării mecanice, L
C20-2		0.0044	0.0044	601	În bară, în afara lungimii îmbinării mecanice, L
C20-3		-0.0057	0.0074	598	În bară, în afara lungimii îmbinării mecanice, L
SR ISO 15835-1:2016		≤0.3	≤0.6	>550	

### Project implemented by

The Research Centre for Mechanics of Materials and Structural Safety – CEMSIG

### Implementation period

20.03.2018–31.10.2018

### Main activities

1. Experimental rebar set-up
2. Tensile tests
3. Cyclic tests

### Financed through/by

SKANSKA CONSTRUCTION ROMANIA SRL

### Research team

Assist. Prof. Călin NEAGU, PhD  
 Assist. Prof. Ioan BOTH, PhD  
 eng. Ovidiu ABRUDAN, PhD  
 Prof. Florea DINU, PhD



### Contact information

Assistant Prof. Călin NEAGU, PhD  
 Faculty of Civil Engineering  
 Department of Steel Structures and Structural Mechanics  
 Address: Str. Ioan Curea, No. 1, 300226, Timisoara  
 Mobile: 0723147750  
 E-mail: calin.neagu@upt.ro

## STUDY FOR SMALL HYDROPOWER PLANTS ON BÂRZAVA RIVER, AS LOCALLY ADAPTED SOLUTION FOR INVESTMENT IN RENEWABLE ENERGY AND PUBLIC UTILITIES INFRASTRUCTURE

### Goal of the project

Under the Romania – Serbia Cross-border Cooperation Program 2014-2020, the study is mainly concerned by the implementation of a small hydropower plant on Bârzava River in the town of Reșița as a local solution for renewable energy infrastructure for public utilities. The general objective is to ensure the right infrastructure for harnessing green hydro-energy under safety high-waters flow conditions on the river-course. Besides supplying the local power network supporting public areas lighting and operation, the project is concerned by the river-bed rearrangement as an urban friendly area.

### Short description of the project

Following flow analysis under existing conditions, the project identifies two accomplishment scenarios from which the technical-economical optimum solution for the water arrangement is reached.

### Implementation period

March 1st, 2018 – May 31st, 2019

### Main activities



Analysis of the existing flow situation and deficiencies recognition: the river-channel discharge capacity on the specific sector (6042m, 180 segments) was established by numerical modeling under three flow levels (the usual mean multi-year, the dimensioning 5% overrunning probability and the special 1%).

Introduction and analysis of three scenarios in order to accomplish the objective: three similar SHPP of 2m<sup>3</sup>/s installed discharge under 2m head each producing a total of about 285MWh; two SHPP of 3m<sup>3</sup>/s installed discharge under 2m head each producing 324MWh; one SHPP installed for 3m<sup>3</sup>/s under 2m head and producing about 162MWh. The flow transition for each power harnessing scenario was numerically modeled and studied for all three enforced incoming flow hydrographs, various discharge capacities being considered at the retaining steps. As a consequence of the shorter affected sector and the lower maximum flow, the third scenario considering the water arrangement with one SHPP on the upstream part came out as prevalent.

### Results

The sharp numerical simulation pointed out the specific steady and time dependent flow parameters – water levels and velocities and discharge progress – for all designated scenarios with respect to arrangement configuration and incoming hydrographs. As analyzing the existing discharging conditions of the urban Bârzava River sector it resulted that the river course is able to transport even the special hydrograph, mentioning that some of the bridges, even if not over-flooded, would go under pressure.

Specific river works – silt removal and river-bed recalibration – would need to be performed in order to ensure even the special safety running.

### Applicability and transferability of the results

With the redevelopment of the urban section of the watercourse, it is possible to exploit this non-polluting energy resource in order to satisfy a part of the public consumption. For the moment, the technical part of the study was disseminated through a scientific paper published in the specialized journal Hidraulica Bucharest (ISSN 1453-7303).

### Financed through/by

Reșița Municipality

### Research team

Albert Titus CONSTANTIN, Alina-Ioana POPESCU-BUȘAN, Gheorghe LAZĂR, Michael ION, Adia GROZAV, Mircea VIȘESCU, Șerban-Vlad NICOARĂ, Constantin FLORESCU, Ioan ȘUMĂLAN, Mihaela PIȘLEAGĂ.

### Contact information

Assist. Prof. Albert Titus CONSTANTIN, PhD  
Faculty of Civil Engineering  
Department of Hydrotechnical Engineering  
Address: 1A George Enescu Street, 300022, Timișoara, Romania  
Phone: (+40) 256 404091  
Mobile: +40 720 059 371  
E-mail: albert.constantin@upt.ro  
<https://www.ct.upt.ro/en/hidro/index.htm>

## DESIGN AND DEVELOPMENT OF TECHNICAL SYSTEMS FOR WOOD PROCESSING MACHINES IN THE FOOD INDUSTRY

### Goal of the project

Technologically and constructive design of the components of a wood stick milling machine for increasing productivity and reducing the dust resulting from the manufacturing process

### Short description of the project

The project involved the establishment of constructive solutions and the selection of materials for the systems of a wood milling machine used in the sticks production for the food industry.

### Project implemented by

Faculty of Mechanical Engineering  
Department of Materials and Manufacturing Engineering

### Implementation period

July–November 2018

### Main activities

The main activities of the project are:

- Constructive design of wood sticks milling machine systems;
- Selection of the materials for the designed parts;
- Technological design of the parts of the wood milling machine;
- Drafting up the technical book of the wood milling machine.

### Results

1. The technical documentation required for the manufacture of a wooden stick milling machine has been made.

### Applicability and transferability of the results

The results obtained allow the production of a wood stick milling machine of high productivity and low dust emission.

### Financed through/by

SMART WOOD ROMANIA SRL

### Research Centre

Research Center for Processing and Characterization of Advanced Materials

### Research team

Associate Prof. Cosmin CODREAN, PhD

Associate Prof. Ion-Dragoş UȚU, PhD

Assistant Prof. Adrian DUME, PhD

Assistant Prof. Aurelian MAGDA, PhD

Assistant Prof. Dragoş BUZDUGAN, PhD

### Contact information

Associate Prof. Cosmin CODREAN, PhD

Faculty of Mechanical Engineering

Department of Materials and Manufacturing Engineering

Address: Bvd. Mihai Viteazu 1, RO-300222 Timisoara, Romania

Phone: (+40) 256 403 647

Mobile: (+40) 722 953 565

E-mail: cosmin.codrean@upt.ro



## IDENTIFYING THE OPTIMUM SOLUTION FOR REPLACING HYDRO-AGGREGATES AT THE CENAD PUMPING STATION

### Goal of the project

The beneficiary "EMILIANA WEST ROM" in Dudeștii Vechi is an agricultural company and calls for the increase in the useful flow given by SP Cenad. To address this, the representatives of SC EMILIANA WEST ROM have requested refurbishment of the Cenad pumping station in order to achieve a flow rate between 4 ... 5 m<sup>3</sup> / s, but involving minimal adaptation of the new equipment in the SP building

### Short description of the project

SP Cenad refurbishment can be done in the following ways:

- Replacing one of the pumps with a larger flow pump;
- Replacement of both pumps, which in parallel operation to provide a flow in the proposed range.

### Implementation period

07.03.2018 – 30.04.2018

### Main activities

- State of the art for "identifying the optimum solution for replacing hydro-agregrades from Cenad Pump Station".
- Analysis of 5 variants and proposal to the beneficiary of the optimal hydraulic and economical solution.

### Results

Following the analysis of the five variants, it leads to the recommendation of applying the solution with the following characteristics:

- Achieves a flow rate of approximately 2.35m<sup>3</sup>/s for drainage at a useful pumping height in SP Cenad.
- Electric motors have rated unit power  $P = 230\text{kW}$ .
- The construction dimensions and installation dimensions of the pumps presuppose work without affecting the structure of the building.
- The electrical transformer and other electrical equipment must be replaced or upgraded.

### Financed through/by

EMILIANA WEST ROM SRL

### Applicability and transferability of the results

The beneficiary immediately implemented the proposed solution by the acquisition and installation of a new pump in the pumping station Cenad with the features shown in the figure below.

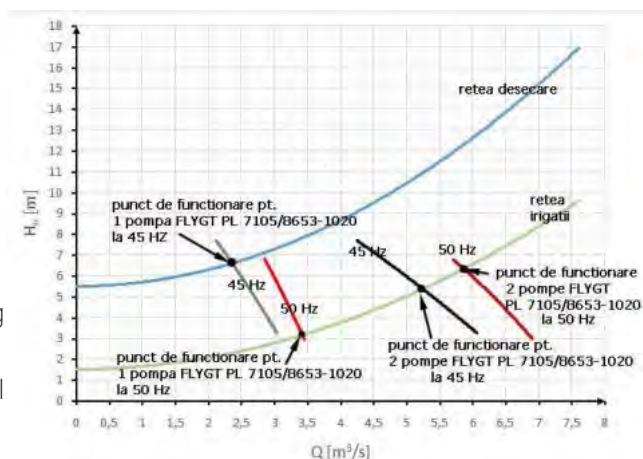

### Research Centre

Research Centre in Engineering Systems with Complex Fluids

### Research team

Eng. Constantin TĂNASĂ, CS III  
Associate prof. Adrian STUPARU, PhD  
Professor Alexandru BAYA, PhD  
Eng. Mariana TODIRUȚĂ

### Contact information

Eng. Constantin TĂNASĂ, PhD  
ICER - Research Institute for Renewable Energies  
Address: str. Gavril Muzicescu, nr. 38, 300501 Timișoara,  
Mobile: 0720 741 338  
E-mail: constantin.tanasa@upt.ro

## COMPLEX MEASUREMENTS FOR THE DETERMINATION OF POLLUTANT EMISSIONS AT THE TIMISOARA (16 MĂCIN STR.), ORAVIȚA, LUPENI AND MARGHITA UNITS OF THE COMPANY TRW AUTOMOTIVE SAFETY SYSTEMS

### Goal of the project

Identifying the level of pollution generated by specific units in the company. Thus, by analyzing the results, the specialists from TRW Automotive Safety Systems can adapt and reconsider their technologies, in order to optimize/ reduce the emissions' levels/concentrations, if they are not appropriate and in correlation with the emission control legislation.

Thus the company can maintain its leading position in the frame of all Romanian production companies, knowing that TRW Automotive Safety Systems gained by 2018 the third place for cooperation in Romania (diploma offered by ListaFirme.ro, 2018).

### Short description of the project

#### TESTS:

- 1.Gravimetric tests (dust) (emissions);
- 2.Electrochemical tests;
- 3.Flame ionization tests;
- 4.Physical tests.

#### SCOPE:

1. Determination of total dusts (emissions).
2. Determination of combustion gas concentrations (O<sub>2</sub>, CO, CO<sub>2</sub>, H<sub>2</sub>S, SO<sub>2</sub> and CH<sub>4</sub>)
3. Determination with flame ionization detector of COV / COT.
4. Determination of physical parameters (pressure, speed and flow).

#### FEEDBACK:

The client is offering a feedback by filling in a specific file, that enables us to improve the offer and cooperation activity for the future.

### Implementation period

23.02.2018-22.02.2019

### Main activities

- Identification of the most representative regimes for measuring
- Identification of the safety conditions for the workers
- Preparation of the measuring points (measuring plan)
- Calibration of the instruments
- Measurements and verification of the results
- Calculations
- Conceiving the report (Technical Bulletin) in accordance with the RENAR specifications



### Results

Technical Bulletins- more than 25/year, in all the working points identified by the Agency of Environmental protection as to be analyzed/monitored on specific intervals, during representative technological episodes.

### Applicability and transferability of the results

- Development of a strategy of monitoring, according to the specific needs of the client.
- Raising the importance of UPT on the free market of collaboration with industrial units.
- Offering to the members of the team a modality to perform, also in industrial cooperation, in addition to the main duties as researcher or university teacher.
- Maintaining the quality for next RENAR accreditation.
- Developing skills and knowhow for all personnel involved.

### Financed through/by

TRW Automotive Safety Systems

### Research Centre

Research Centre for Thermal Machines and Equipments, Transportation and Environmental Pollution Control,

### Research team

Ioana IONEL, Ramon Mihai Balogh, Delia Gabriela TRIF TORDAI  
Daniel BISORCA, Virgil STOICA, Gabriela NAGY, Gavril BRATEANU

### Contact information

Prof. Ioana IONEL, PhD  
Faculty for Mechanical Engineering/  
LACIEDIN in the Research Centre for Thermal Machines and Equipments, Transportation and Environmental Pollution Control,  
Address: Mihai Viteazu No. 1, Postal Code 30222, Timisoara, Romania  
Phone: (+40) 256 403670  
Mobile: (+40) 723349337  
E-mail: ioana.ionel@upt.ro  
Web: www.mediu.ro

## ENVIRONMENTAL IMPACT STUDY, FROM THE POINT OF VIEW OF THE OPPORTUNITY OF RELOCATION OF THE TM-1 STATION IN THE FRAMEWORK OF THE NATIONAL AIR QUALITY RESORT STATIONS

### Goal of the project

The study thus supports with scientific arguments (on-line monitoring and updated dispersion study on the structure of the traffic, provided by the beneficiary) the possibility of moving the air quality monitoring station from the present position, being motivated by the current tendency of modernization of the municipality through the implementation of the works of Șagului Road - Ana Ipătescu section with the administrative limit of Timișoara municipality.

### Short description of the project

The contract provided:

- A dispersion study on the environmental impact of the modernization project in the exploitation phase;
- Critical analysis of the state of modernization of the Șag Path - Ana Ipătescu section, regarding the location of the TM-1 station;
- Conclusions regarding the possibility of relocation of the TM-1 station to the new location.

It is noted that the study, based on the contract, only refers to air quality, meaning that only the influence of the expected area development project on air quality is analyzed.

### Implementation period

December 2018

### Main activities

**Phase I** - Measurements of air quality (concentrations of major pollutants: NO, NO<sub>2</sub>, NO<sub>x</sub>, CO, VOC, PM<sub>10</sub>) using credited procedures conforming to the RENAR authorization owned;

**Phase II** - Numerical simulation of dispersions (for NO<sub>x</sub> species), having the stages

**Phase III.** Explanations supporting point of view and conclusions, resulting from the complex analysis of points I and II, with reference to TM-1 station monitoring capability in the two new locations proposed by the study.

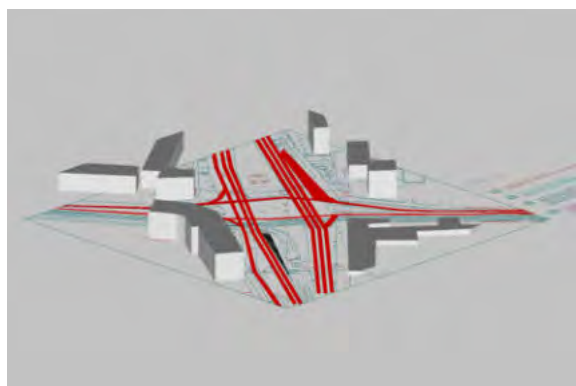

### Applicability and transferability of the results

Transferability:

- Other similar development strategies of the city
- Modality to achieve the validation of the numerical simulation by using an on line monitoring campaign, on spot.

Applicability

The relocation of the station to POSITION 1 or POSITION 2 from the present position would have an advantage over this location because the proposed variants comply with the provisions of Annex no. 5 point 2 of the Law no. 104/2011, corroborated with the provisions of GD no. 336/2015 as updated in 2016 and in force at the date of this report, in compliance with the limit values set for the purpose of human health protection. Thus, one concluded that the concentration values that are allowed for following situation are totally respected:

- All locations in areas where the public has no access and where there are no permanent dwellings;
- On the roadside and on the road, as well as on the spaces separating the direction of their journeys, except where pedestrians normally have access to those spaces.

### Financed through/by

SALIGNY CONSTRUCTIONS SRL.

### Research Centre

Research Center for Machinery and Thermal Equipment, Transport and Pollution Control

### Research team

Ioana IONE, Daniel BISORCA, Delia Gabriela TRIF TORDAI, Ramon Mihai Balogh, Virgil STOICA, Gabriela NAGY, Gavril BRATEANU

### Contact information

Prof. Ioana IONEL, PhD  
Faculty for Mechanical Engineering  
LACIEDIN in the Research Centre for Thermal Machines and Equipments, Transportation and Environmental Pollution Control,  
Address: Mihai Viteazu No. 1, Postal Code 30222, Timișoara, Romania  
Phone: (+40) 256 403670  
Mobile: (+40) 723349337  
E-mail: ioana.ionel@upt.ro  
Web: www.mediu.ro

## MONITORING THE QUALITY OF WASTES FROM TECHNOLOGICAL PROCESS

### Goal of the project

The goal of the project is to monitor the quality of wastes from technological process.

### Short description of the project

In the project the toxic compounds from wastes from the technological process are monthly analyzed. Samples of solid and liquid wastes are analyzed.

### Project implemented by

Faculty of Industrial Chemistry and Environmental Engineering,  
Department of Applied Chemistry and Engineering of Inorganic Compounds and Environmental.

### Implementation period

November 13, 2017 until November 14, 2018

### Main activities

The main activities of the project are:

- Analysis of volatile compounds (COV) from solid and liquid waste.
- Leaching testes for sludge to be placed in a class of waste.
- Analysis of the following parameters: Cr<sup>3+</sup>, Cu<sup>2+</sup>, Ni<sup>2+</sup>, Cd<sup>2+</sup>, Pb<sup>2+</sup>, Zn<sup>2+</sup>, pH and humidity of the sludge.
- The main parameters are analyzed once a month in according to the project plan.

### Results

1. The volatile compounds (VOC) from waste were analyzed.
2. The concentration of heavy metals in the sludge was determined.
3. Sludge leaching testes were made.

### Applicability and transferability of the results

- Improved university-industry relationships.
- Updating curricula in accordance with the economic realities of the local area.
- The results are consistent with the legislative framework in force.
- Adoption by the university of new mechanisms and management techniques resulted from the project activities.

### Financed through/by

S.C. FLEXTRONICS ROMANIA S.R.L.

### Research Centre

Research Center of Environmental Sciences and Engineering

### Research team

Assistant Prof. Mihaela CIOPEC, PhD  
Professor Adina NEGREA, PhD

### Contact information

Assistant Prof. Mihaela CIOPEC, PhD  
Faculty of Industrial Chemistry and Environmental Engineering,  
Department of Inorganic and Applied Chemistry and Environmental Engineering,  
Address: Bv. Vasile Pârvan, No. 6, RO300223, Timisoara  
Phone: (+40) 256 404192  
Mobile: 0722806880  
E-mail: mihaela.ciopec@upt.ro

## CONSULTING FOR THE USAGE OF MACHINE LEARNING FOR MACHINE VISION APPLICATIONS

### Goal of the project

Machine learning consists of scientific study of algorithms and statistical models that computer systems use to effectively perform a specific task. Machine learning algorithms are used in a wide variety of applications (as computer vision is) where it is infeasible to develop an algorithm of specific instructions. Data mining is a field within machine learning, and focuses on exploratory data analysis through unsupervised learning. In its application across business problems, machine learning is also referred to as predictive analytics.

EVT has developed machine vision products, which not only allow precise and error-free image processing, but also products, which are one step ahead of the market. The machine vision software EyeVision by EVT is a product, which due to easy-handling is able to adopt to various applications. The research trends for it follow to enhance easy programming, easy-handling, versatility, extensibility and to get fast solutions.

### Short description of the project

EyeVision is a complete image processing package for every possible field of application. EyeVision is connecting a powerful, hardware platform independent software for Windows and Linux with a wide range of hardware for image capture and digital I/O.

All industrial inspection tasks are done fast and effective by the all-in-one image processing software EyeVision.

### Implementation period

01.04.2018 - 01.04.2020

### Main activities

- Image Processing largely involves several processes to gain information from source data, such as for example image recognition and pattern matching. With the usual methods for image processing one can for example count objects, measure, inspect or read coded information. Image processing nowadays is used in nearly every science and engineering disciplines. One domain for image processing is the quality control at production processes such as automotive engineering, electrical and semiconductor industries, food industry and pharmaceutical industry.
- We focused on research and development of the hardware platform independent software for Windows and Linux - technical. We offer consultancy in the field of all-in-one image processing software.
- Consulting services for using applications at Machine Learning for Machine Vision.

### Results

- Machine Vision Software for VisionSensors, SmartCameras and PC Systems - EyeVision the one software for all Hardware Platforms.
- For programmers a PlugIn Interface was made, which supports easy to integrate software modules.
- The software supports all major interfaces for cameras e.g. USB, FireWire, GigE, CL, CoaXPress and analog.

### Applicability and transferability of the results

- A build in WebServer for easy remote control as well as interfaces to SAP Oracle and SQL.
- EyeVision Software is available.

### Financed through/by

EVT Eye Vision Technology GmbH, Karlsruhe Germany

### Research team

Prof. Ivan BOGDANOV, PhD

### Contact information

Prof. Ivan BOGDANOV, PhD  
Faculty of Electronics, Telecommunications and Information Technology  
Department of Applied Electronics  
Address: Bvd. Vasile Parvan, No.2, 300223, Timisoara  
Phone: (+40) 256 403 338  
E-mail: ivan.bogdanov@upt.ro

## SOFTWARE MODULE FOR THE ENERGETIC ASSESSMENT OF HYDRAULIC GENERATORS OPERATION IN AQUATIM'S DRINKING WATER SYSTEM

### Goal of the project

The goal of the project was to create a simple to use software system validated by experimental results for the quick assessment and monitoring of the efficiency of hydraulic generators deployed in Aquatim's Drinking Water System.

### Short description of the project

The project contained three phases:

**Phase 1 27.03.2018 – 30.06.2018**, for the development of the algorithms for constant-speed pump efficiency assessment and variable-speed pump efficiency assessment.

**Phase 2 01.07.2018 – 30.09.2018**, for the validation and testing of the software module against laboratory experimental data from a variable-speed pump.

**Phase 3 01.10.2018 – 27.12.2018**, for the development of the graphical user interface for the central desktop system and for the mobile, smartphone application.

### Main activities

- The development of a software module for the energetic assessment of hydraulic generators operation in Aquatim's Drinking Water System in two parts: the desktop application and the smartphone application.
- All software results have been validated with in situ and laboratory experiments for constant-speed pumps and for variable-speed pumps.



### Results

An interdisciplinary expert software solution for the energetic assessment of hydraulic generators operation in Aquatim's Drinking Water System in two parts: two desktop applications and the smartphone application.

The desktop applications generate QR code stickers for each hydraulic generator configuration for constant-speed pumps and for variable-speed pumps.

The QR codes are scanned by the mobile application which works both for constant-speed pumps and variable-speed pumps. The hydraulic route is encoded in the QR codes in addition to polynomial curve fitting coefficients, in order to allow the correct assessment of the efficiency for each pump configuration.

### Applicability and transferability of the results

- The results are tailored for the energetic assessment of hydraulic generators operation in Aquatim's drinking water system.



### Implementation period

23.02.2018-22.02.2019

### Financed through/by

AQUATIM S.A.

### Research Centre

Research Center in Computer and Information Technology (CCCTI)

### Research team

Assist. Prof. Alin-Adrian ANTON, PhD  
Eng. Daniel Calin MOS, PhD Student  
CS1 Sebastian MUNTEAN, PhD

### Contact information

Assistant Prof. Alin-Adrian ANTON, PhD  
Faculty of Automation and Computers  
Department of Computer and Information Technology  
Address: BvdI. Vasile Parvan no.2. 300223, Timisoara  
Phone: (+40) 256 403 281  
Mobile: (+40) 745 001010  
E-mail: alin.anton@cs.upt.ro  
Web: <http://staff.cs.upt.ro/~alin.anton>

## ANALYSIS OF THE MATERIALS FROM THE PRODUCTION PROCESS

### Goal of the project

Structural analysis and mechanical testing of materials used in production of heating elements and systems, in order to optimize the material selection criteria for processing tools and devices as well as the final products.

### Short description of the project

The project consisted in analyzing of the materials used in the production of heating elements and setting criteria for selection of these materials.

### Implementation period

November-December 2018

### Main activities

- Structural analysis and hardness testing of cold working tools in different heat treatment states;
- Structural analysis and hardness testing of stainless steels used in the manufacture of tubular heaters;
- Establishing the influence of the manufacturing process parameters on the structure and properties of steels used in the tubular heaters production;
- Optimizing the material selection criteria for the production of tubular heaters.

### Results

It has been optimized the material selection for the production of tubular heaters elements in order to reduce the scrap.

### Applicability and transferability of the results

The results obtained help design engineers to optimize the selection of materials in order to increase products quality and reduce the scrap.

### Financed through/by

SC ZOPPAS INDUSTRIES ROMANIA SRL

### Research Centre

Research Center for Processing and Characterization of Advanced Materials

### Research team

Associate Prof. Cosmin CODREAN, PhD

Prof. Corneliu CRĂCIUNESCU, PhD

Associate Prof. Daniel STAN, PhD

Associate Prof. Bogdan RADU, PhD

Associate Prof Ion-Dragoș UȚU

Assistant Prof. Carmen OPRIȘ, PhD

Assistant Prof. Dragoș BUZDUGAN, PhD

### Contact information

Associate Prof. Cosmin CODREAN, PhD

Faculty for Mechanical Engineering

Department of Materials and Manufacturing Engineering

Address: BvdI. Mihai Viteazu 1, RO-300222 Timisoara, Romania

Phone: (+40) 256 403 647

Mobile: (+40) 722 953 565

E-mail: cosmin.codrean@upt.ro

## ELECTRICA MUNTENIA NORD DISTRIBUTION NETWORK OPERATOR ANALYSIS AND OPTIMIZATION

### Goal of the project

Distribution network technical losses evaluation for Electrica Muntenia Nord Distribution System Operator has been tackled. Analytical and power flow computing based methods have been applied for different voltage levels and operating conditions. Renewable generation influence has been discussed.

### Short description of the project

Technical losses computing methodology is proposed.

### Implementation period

2018

### Main activities

- The study was conducted for Electrica Muntenia Nord Distribution System Operator. It was focused on different voltage levels, distribution branches and equipment type.
- Quantitative and qualitative on-field measurements have been provided and discussed, followed by the technical losses evaluation. Different scenarios for the distribution network operator have been taken into consideration highlighting the optimal operating conditions.



### Results

- algorithm developed for technical losses evaluation in case of different voltage levels;
- electrical distribution network simulation model at 110 kV and 20 kV voltage levels, analyses, recommendations;
- technical losses' reduction methods.

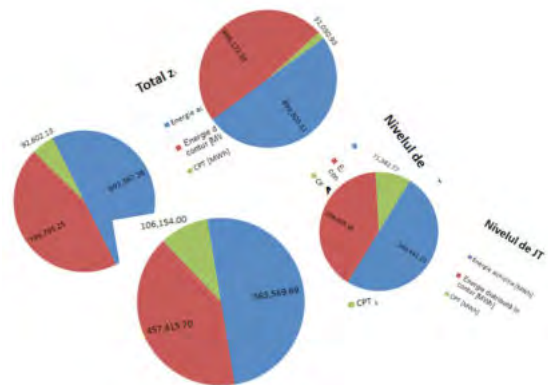

### Applicability and transferability of the results

- The developed methodologies for technical losses evaluation are able to be applied in case of any distribution network operator. Also, based on the achieved experience, other (or similar) technical losses reduction methods could be tackled in case of different distribution operators.

### Financed through/by

Servelect Cluj-Napoca

### Research Centre

Power Systems Analysis and Optimization Research Centre  
Department of Power Systems

### Research team

Prof. Stefan KILYENI, PhD  
Assoc. Prof. Constantin BARBULESCU, PhD  
Lecturer Annamaria KILYENI, PhD

### Contact information

Prof. Stefan KILYENI, PhD  
Faculty of Electrical and Power Engineering  
Department of Power Systems  
Bd. V. Parvan, No. 2, 300223, Timisoara  
Phone: (+40) 256 403 416  
E-mail: stefan.kilyeni@upt.ro  
Web: www.et.upt.ro



## PROTOTYPE RESEARCH AND DEVELOPMENT FOR IMAGE PROCESSING SOLUTION FOR BOARDS TESTING IN THE AUTOMOTIVE INDUSTRY

### Goal of the project

The main goal of the project is to obtain a prototype, able to execute boards inspection, based on image processing, functioning in accordance with the company requirements for the production line.

### Short description of the project

The starting point of the project was represented by an experimental model. The activities were to adapt, to improve, to test and to validate the software from the experimental model within a new mechanical-hardware structure in order to obtain a prototype that is able to perform ECU tests based on image processing functioning in accordance to the Hella company requirements in the production line.

### Implementation period

22/11/2018-22/03/2019

### Main activities

The prototype was conceived and implemented, and the solution was integrated, tested and validated in the production line.

### Results

Some results are detailed below:

- 1) Starting from the experimental model (consisting of 4 compact modules, each containing a Raspberry Pi and a camera), the solution was modified within the prototype in order to fit the high number of different ECUs from the production line and to reach the test indicators. A prototype solution was conceived and implemented, based on 6 Raspberry Pis and 6 cameras, this time physically separated, and improving the quality of the inspection for the connectors with perspective issues. Having separated cameras, the prototype allows besides higher possibilities to eliminate the perspective, a higher luminosity on the ECUs analyzed surface.
- 2) The capability to vehiculate data between 1 master and 5 slaves, including from request/response transmissions toward data aggregation, concluding procedures and reporting.
- 3) A generic platform was created for n processing modules. Therefore now, the prototype contains only two branches: 1 master branch and 1 slave branch, and the software from the slaves is generic for any Raspberry Pi slave in the scheme.
- 4) The prototype solution is extended to function for the 4 main classes of ECUs from the production line. The extension required a whole new concept for the software module.
- 5) Modules were conceived and developed to include layouts from all main classes of boards and all the particular sets of boards inside the main classes.

- 6) The pin search module was optimized to reduce the search area and the processing times.
- 7) New detection modules were researched and implemented based on islands identification, separation and grouping, for more accurate conclusions.
- 8) A new method was researched and developed to establish a dynamic illumination threshold associated to each pin.
- 9) The layout saving, storing and loading was optimized due to the high number of layouts in the production line.
- 10) Detection task request optimizing was researched and implemented mainly in a sense that the master equipment extracts and sends a list of the connectors to analyze for each slave equipment. This procedure eliminates the fix slaves, each being able to be replaced without application issues.
- 11) The processing time was significantly reduced by eliminating the necessity of connector rotation for the slave's software.
- 12) A new module was implemented for new layout learning, placed only on the master equipment. This way no ssh/vnc connection is necessary for each slave.
- 13) A new offset (search area) separation was researched and implemented so that each pin has now its own offset. Also, a new module was created that establishes the filling factor for the offset for each pin.
- 15) The prototype is able to apply all the changes in configuration from the graphical user interface.
- 16) The prototype functions in complete correlation with the traceability software within the company.

### Financed through/by

HELLA ROMANIA S.R.L.

### Research team

Adrian Stefan KORODI, Ioan SILEA, Alexandru Brian BOITOR  
Denis Florin ANITEI, Mariana Daniela GIUCHICI

### Contact information

Assistant Prof. Adrian KORODI, PhD  
Faculty of Automation and Computers Science  
Department of Automation and Applied Informatics  
Address: Bd. Vasile Parvan, No. 2, 300223, Timisoara  
E-mail: adrian.korodi@upt.ro



# PATENTS



## EVOLUTION OF PATENTS UNDER AFFILIATIONS OF UPT 2014 - 2018

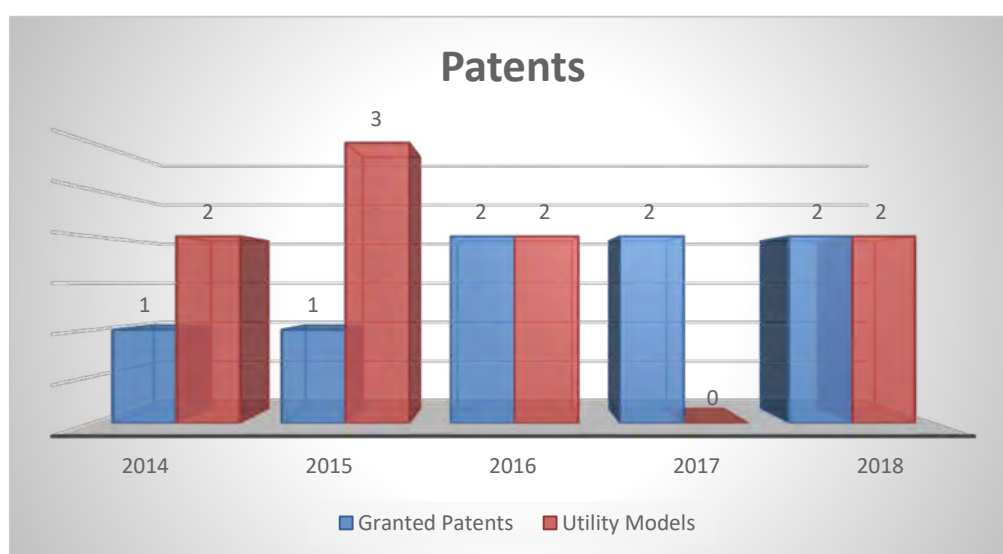

The innovative capacity of the Politehnica University Timisoara is supported by teachers and scientific researchers through patents and utility models invented, presented in this section.



# Granted Patents





INVENTOR: ICLĂNZAN TUDOR ALEXANDRU

PATENT NO. 129774 / 2018

## MUNICIPAL WASTE COLLECTION PLANT



The invention refers to a household waste collection plant in public spaces and in the vicinity of housing.

The installation consists of a support frame structure for several containers that can be ordered underground. In the above-ground shifts with openings or flap, access to containers is provided. The structure of the support frame is balanced by two lateral counterweights with the role of easing the lifting and lowering of the structure with containers, making it a central mechanical screw-nut system from a gear motor Portable alternating current have been continuously available at the operator. Each container is stapler to refer the filling state to gravimetric and transmit signals to a GSM communicator in connection with the computer server in the sanitation company's premises to rationalise the download site of containers with Waste. The plant for the collection of municipal waste according to the invention, presents the following advantages:

- presents a simple and inexpensive construction that can be ordered in an underground cavity;
- minimise possible pollution due to the collected residues and aesthetic pollution in the vicinity of public spaces;
- It is easy to handle for emptying and repositioning either by electro-mechanical actuation due to the weight balancing of the container's underlying structure;
- Allows the identification of the filling state of containers allowing rationalisation of operations related to use;

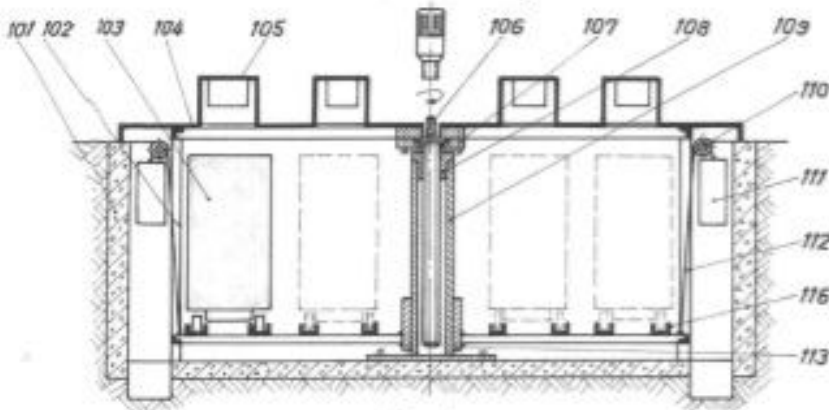
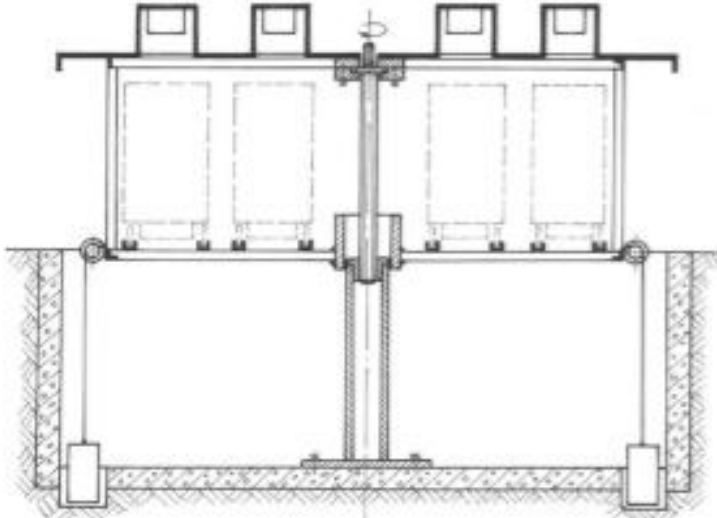

Fig. 1

A-A (deschis)



INVENTORS: SÎRBU NICUȘOR-ALIN, ȘERBAN VIOREL-AUREL

PATENT NO. 130336 / 2018

## ULTRASONIC DEVICE FOR EVALUATION OF THE MELT FLOW OF POLYMERIC AND COMPOSITES MATERIALS



The invention relates to an ultrasonic device used for the evaluation of the melt flow of polymeric and composite materials, which can be used in academic, research and development areas, as well as in the chemical industry, in the manufacturing industry of polymeric materials and composites, in order to evaluate the flowing process due to the beneficial effects of the micro-vibrations with ultrasonic frequency, respectively the increase of the flow rate and reduction of the processing flaws. The ultrasonic device is built in a compact manner and can be easily positioned and fitted on classical processing equipment for polymeric materials by injection or extrusion.

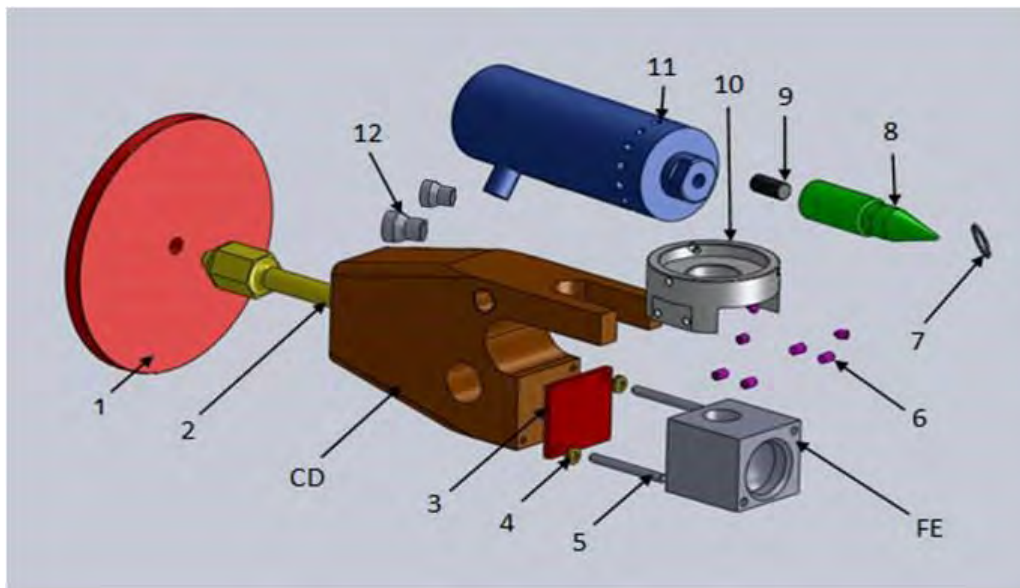

According to the invention, the ultrasonic device for the evaluation of the melt flow rating of polymeric and composite materials is composed of an ultrasonic assembly (AU), which includes a piezoceramic transducer (11), a cone-headed cylindrical sonotrode (8), in steps, the fitting (9) and the heat-resistant silicone rubber ring (7) which seals and centres the ultrasonic assembly (AU) relative to the extrusion dies (FE). Positioning, fixing and adjusting of the ultrasonic assembly (AU) in the device's body (CD) and in relation to the extrusion dies (FE), which provides also the technological parameter "flow gap - i", is realized either by positioning the holder (10) in relation to the device's body (CD), using a set of feeler gauge of different thickness or by using the screw-nut mechanism, fine-pitched, located in the assembly area of the support (10) and the piezoceramic transducer (11).

In both cases, the mounting of the adjusted position is realized with threaded bolts (6). The positioning and fixing of the ultrasonic device

between the plates (fixed and mobile) of the injection or extrusion classic equipment of the polymeric materials or polymer composite melt is realized through the screw-nut mechanism (1 and 2) and the reducing or even eliminating the heat transfer between the device body (R) and the extrusion dies (FE) is carried out by using a thermal insulation textolit (3) and two distance plates (4), which are positioned by means of threaded head guides (5), which are fixed on the device's body (CD) in threaded borings.

Also, the ultrasonic device is equipped with an air cooling system (E) on the piezoceramic transducer (11) and on the device's body (CD); the fixation of the cooling system on the device's body (CD) is realized through rapid coupling (12). It is mentioned that there is a possibility of the extrusion dies (FE) to be changed according to the technological requirements (size and shape) of the process. So interchangeability can be done easily, achieving a new product involving minimal costs.

# Utility Models



INVENTORS: PAVEL ȘTEFAN, KREMS CRISTINA, MOCAN MARIAN LIVIU,  
DOBOSI IOAN SILVIU

UTILITY MODEL NO. RO 2017 00018

## ELECTRICAL LIGHT INSTALLATION FOR DENTAL ESTHETICS



The invention relates to a fixed electrical lighting installation used in dental cabinets, which provides illumination on the patient's dental area, close to the lighting parameters of the daylight. The installation is made of folding metal body of stainless steel sheet, fixed on the dental unit pillar, in which 5 lamps are mounted with the true color rendering index of 97 Ra8, and a color temperature of 5300 Kelvin, a black light lamp, and between the lamps it is mounted a camera which is connected to a computer with a fixed monitor (optional) on the dental unit pillar.

Benefits:

- Ensures transparency in the incisal teeth;
- Ensures an illumination on the dental area, illumination which is close to the lighting parameters of the daylight;
- Ensures that the teeth are photographed with a light closer to the lighting parameters of the daylight before and after the medical protocol in dental esthetics;
- Ensures a better establishment of the color in dental esthetics;

INVENTORS: PAVEL ȘTEFAN, SUCIU SILVIU-CRISTIAN

UTILITY MODEL NO. RO 2015 00045

## PORTABLE DEVICE FOR DISINFECTING AIR AND SURFACES FROM CLOSED SPACES



### Description:

The invention relates to a portable electrical installation used for disinfecting the air and the surfaces of closed spaces, as example: attic, basements of buildings, warehouses, polluted rooms from hospitals and another spaces without sufficient ventilation or insufficiently disinfected by common means.

### Benefits:

- The installation is portable and easily maneuverable;
- Ensures the monitoring of the operating time of the germicidal lamps necessary for a more efficient maintenance of the installation;
- Provides the monitoring of the consumption of electrical energy;
- Ensures the possibility of hourly programming of the operating system;
- Provides the possibility of adjusting the distribution of the germicidal light on a designated area;
- Provides additional protection through the operation of the installation only in the absence of the operator;
- Ensures energy efficiency through lower power consumption;
- Provides safety in operation of the installation, being operated in one operation by a single-switch, with key by a single operator;
- Provides easy maintenance by cleaning the lamps of dust or replacing them when the number of hours of operation has elapsed.



# HONORARY MEMBERS



## EVOLUTION OF HONORARY MEMBERS OF UPT 2014 - 2018

The conferring of honorary degrees is one way in which the University recognizes individuals distinguished by accomplishments consonant with the overarching mission of the University.

Nominees may be eminent scholars, scientists, artists, or professionals who have advanced their disciplines in important ways, or they may be individuals outside of the academic world who have made particularly distinguished contributions to society.

Politehnica University Timisoara recognizes scientific excellence by conferring the honorary degree of Doctor Honoris Causa and Honorary Professor to distinguished Researchers for their contribution to the development of UPT and continuous support.

The University strives for a robust pool of honorary degree recipients enriched by individuals from all backgrounds of engineering.

We also find it rewarding to honor individuals who have not already been publicly recognized by a number of other institutions.

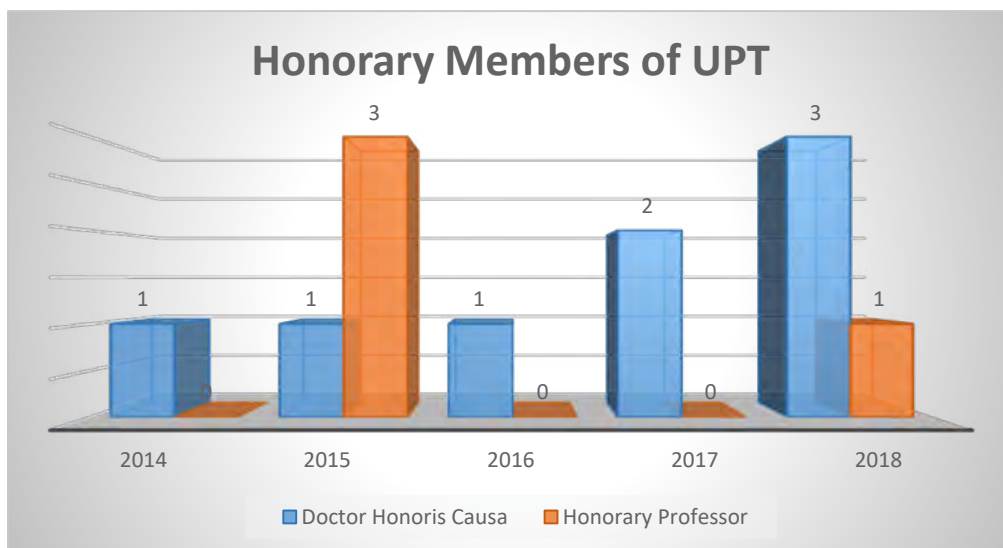



## DOCTOR HONORIS CAUSA

### Dr. Phys. Attila Michael BILGIC, Krohne Group Duisburg, Germany

Dr. Attila Michael Bilgic studied Physics at Dortmund University and was awarded an Engineering title in theoretical Physics of solids in 1996. Between 1996 and 2000 he continued his Ph.D. studies at the same university and in the year 2000 he was awarded the title of Ph.D. Engineer in the area of microwave engineering. Thenceforth Dr. Attila Bilgic started his career in industry, working for Infineon Technologies AG, developing UMTS 3rd generation communication systems. Starting with 2004 he becomes a member of the Corporate Software Group of the Infineon Technologies, where he was in charge of the team working on defining software architecture for all application levels and multimedia Infineon platform protocols for mobile terminals.

Starting with April 2007 he has fulfilled an academic position as professor and Department Leader for Integrated Systems at Ruhr-University-Bochum for a period of 3 years.

In 2009, Dr. Attila Bilgic was appointed Managing Director and CTO at KROHNE Group, and in 2017 he became Managing Director of Ludwig KROHNE GmbH & Co KG. In this context, Dr. Attila Bilgic has taken over global responsibility for research and development and expands the management team of KROHNE Group. The focus area is mainly intelligent sensors, in which KROHNE performed pioneer activities with many projects under his supervision.

Dr. Attila Bilgic displays a rich and very fruitful scientific research activity. The areas he focuses on are: integrated system architecture for multi-standard wireless communications, architecture for software and integrated systems, hardware-software co-design, measuring systems, intelligent sensors, sensor networks.

His scientific creativity is also shaped into 22 patents, which protect his inventions, as well as the ones registered with the staff he coordinated. The list of the patents of Dr. Attila Bilgic's inventions include applications still being examined, but also patented inventions by the United States Patents and Trademark Office (USPTO). The areas he tackled include intelligent measuring devices, multiprocessor communication systems, efficient data transmission, adaptive filters, correction frequencies for radio communication, etc. It really is an outstanding activity, which highlights the pragmatic manner in which Dr. Attila Bilgic's research activities have been primarily directed towards practical applications of great economic resonance.

Dr. Attila Bilgic has a long and fruitful cooperation activity with the Politehnica University of Timișoara which started in 2007:

- Dr. Attila Bilgic participated in preparing, managing and finalizing the eMuCo European project, supported by the FP7 framework



program for technological research and development during 2008-2010 which he coordinated. In the eMuCo project, a significant number of teachers, some Master's, Ph.D. students and researchers from the Computers Department of UPT were involved, and a significant number of thesis and doctorates were finalized.

- Due to the excellent mutual collaboration relationships, in December 2015, as a result of Dr. Attila Bilgic's endeavors, Dr. Eng. Dacian Tudor and Prof. Dr. Eng. Vladimir-Ioan Crețu, the management of the Politehnica University Timișoara, represented by Prof. Dr. Eng. Viorel-Aurel Șerban, UPT Rector, and the KROHNE subsidiary in Romania, S.C. KROHNE Solutions S.R.L. signed a framework agreement for Research-Development and Consultancy which sets the general context of the cooperation in order to deliver research and development services for software and hardware systems by the teachers and diploma, Master's and Ph.D. students from UPT.

- KROHNE is one of the active sponsors within the IT area for UPT, and it has been generously contributing to the course of specialized conferences (all the SACI conferences organized by UPT in collaboration with Obuda University from Hungary), awarding distinguished students, great events as the anniversary of half a century for the first Computers' School in Romania at UPT, and other academic events.

## DOCTOR HONORIS CAUSA

### Professor Hamido FUJITA, Iwate Prefectural University, Japonia

Professor Hamido Fujita has started his academic career at the Universite de Montreal, Quebec, Canada. He came back to Japan in 1997, where he became an executive committee member to establish the Iwate Prefectural University (IPU). He joined IPU, Faculty of Software and Information Science, in April 1998, as a Professor and Director of the Information Systems Institute, directing two IPU labs, the Intelligent Software System Laboratory and the Cognitive Systems Laboratory.

He held several managerial positions at IPU. He was a member of the committee that has established in 2000 the Graduate School of Software Science, which has implemented the concept of education centred on approaches specific to software practices. He is the Director of the Intelligent Software Systems Laboratory. Since 2005 he is the founder and Director of the Advanced Research Institute on Software Strategies (ARISES), an incubator of both academia and software industry, to establish the best practices to build integrated services. He is a Graduate Studies Professor at Laval University, Quebec, Canada.

He has published more than 100 papers in journals with high impact factors. The level and number of papers have contributed to be nominated as a member of the editorial boards of several journals indexed in Clarivate Analytics Web of Science (WoS).

He is the Vice-president of the International Society of Applied Intelligence. He has founded in 2000 the Software Methodologies, Tools and Techniques (SOMET) Society; the society has organized annually the SOMET conferences, with proceedings published in IOS Press and/or IEEE Xplore, most of them being indexed in WoS.

He has directed and is currently leading more than 10 projects, with a total value of more than 10 million USD, supported by the Ministry Education, Culture, Sports, Science and Technology (MEXT) of Japan, research organizations and companies, in the fields of software technologies and intelligent systems. He got nine patents in the field of software systems, in European Union, Canada, China and Japan. He was invited to many universities in European Union, USA and Canada: University of Paris 1, Sorbonne, France, Stockholm University, Sweden, Oregon State University, Corvallis, USA.

He has been awarded the Doctor Honoris Causa title of Óbuda University, Budapest, Hungary, in 2013, and the Honorary Professor title of the same university in 2010. He got the Honorary Scholar Award from the University of Technology, Sydney, Australia, in 2012. He is an Adjunct Professor of Stockholm University, Sweden, University of Technology, Sydney, Australia, National Taiwan Ocean University, Taiwan, China.

Professor Hamido Fujita has carried out and is currently carrying out an uninterrupted cooperation with the Politehnica University Timișoara through his position as a Doctor Honoris Causa of the Óbuda University, Budapest, Hungary, a member of the International



Advisory Board of the Doctoral School of Applied Informatics and Mathematics of this university and as an Invited Professor in this university on several time intervals.

He supports the organization of the IEEE International Symposia on Applied Computational Intelligence and Informatics (SACI), which take place at the Faculty of Automation and Computers of UPT. The SACI symposium has reached its 12th edition in 2018, being launched in 2004 as an expression of the cooperation between the two partner universities, Óbuda University and UPT.

He has given two plenary talks of special actuality and interest at the 2012 and 2015 editions of SACI. These talks have contributed to setting a high level of the SACI symposia.

The SACI symposium is technically cosponsored by the IEEE Systems, Man, and Cybernetics (SMC) Society.

Professor Hamido Fujita has contributed to increasing the visibility of the journal of the Faculty of Automation and Computers of UPT. He has published a paper in September 2012 in the Scientific Bulletin of the Politehnica University Timisoara, Romania, Transactions on Automatic Control and Computer Science.

## DOCTOR HONORIS CAUSA

### Prof.em.dr.habil. Gyde HANSEN, Copenhagen Business School, Denmark

Gyde HANSEN is Professor Emerita of the Business Communication Department at the prestigious Copenhagen Business School (CBS), ranked 201–250 according to World University Rankings 2018.

It is noteworthy that Professor em. dr. habil. Gyde HANSEN is an ad vitam member of the European Society for Translation Studies (EST) and former vice-president of the Society for two mandates in the period 2004–2010. The European Society for Translation Studies (EST) is an international network of researchers in the field of translation and interpretation, and at the same time the most important academic forum in these fields worldwide. Founded in Vienna in 1992, the Society now has over 500 members in more than 46 countries.

She has been working as a consultant, expert, or specialist in important organizations and societies such as IATI (International Academy for Translation and Interpreting), NAATI (National Accreditation Authority for Translators and Interpreters, Australia, consultant), EST (European Society for Translation Studies, consultant), Research Council of Norway (expert), SNF (Schweizerischer Nationalfond zur Förderung der Wissenschaftlichen Forschung, Switzerland, expert), Interpreting Studies, University of Heidelberg, Germany (accreditation committee member), Translation research, University of Innsbruck, Austria (accreditation committee member), European Commission's Directorate-General for Translation (DGT) – the European Master of Translation (EMT) (contact person).



Gyde Hansen is an active presence in the boards of reviewers at several prestigious journals and academic publishing houses, such as International Journal for Language, Translation and Intercultural Communication (Epirus, Greece, 2013–present), Studia Translactorica (University of Wrocław, 2011–present), Professional Communication and Translation Studies (Politehnica University of Timișoara, 2009–present), "redit" – Revista Digital de la Didáctica de la Traducción e Interpretación (Spain, 2007–present), Gunter Narr Verlag, Translationswissenschaft (Tübingen, Germany, 2004–present), ARK and Cebal (Copenhagen Business School, 1986–1998).

The collaboration between Gyde Hansen and Politehnica University Timișoara, Faculty of Communication Sciences, Department of Communication and Foreign Languages started in 2008 and resulted in a series of didactic, research and publishing activities, including:

- Participation as a guest lecturer at the International Student Workshop Translating Pragmatic Texts, organized under the Translation Studies Today Series (2009)
- Convener of the German language tracks at the Professional Communication and Translation Studies conference, organized by the Department of Communication and Languages, UPT (4 editions of the conference in 2009, 2013, 2015, 2017)

- Plenary speaker at the Professional Communication and Translation Studies conference, 8th edition (2013), with the topic From Translation to Translation Revision
- Member of the Scientific Committee of the Professional Communication and Translation Studies Conference (5 editions of the conference in 2009, 2011, 2013, 2015, 2017)
- Co-organizer and speaker at the International Round Table Editing in the Humanities and Social Sciences, Politehnica University Timișoara (2015)
- Co-organizer and speaker at the International Round Table Doing PhD research in Translation Studies: Trends and Perspectives, Politehnica University Timișoara (2017)
- Reviewer of the Professional Communication and Translation Studies proceedings published by Politehnica Publishing House (10 issues, starting with Volume 2/2009 to date)
- Reviewer of the Scientific Bulletin of Politehnica University Timișoara, Transactions on Modern Languages (6 issues, starting with issue 12/2013 to date)
- Co-editor, with Daniel Dejica, Peter Sandrini and Iulia Para, of Language in the Digital Era. Challenges and Perspectives, published by Walter DeGruyter (2016).

## HONORARY PROFESSOR

### Prof. PAVOL BAUER, PhD, Delft University of Technology, Netherlands

Pavol Bauer is currently a full Professor with the Department of Electrical Sustainable Energy of Delft University of Technology and head of DC Systems, Energy Conversion and Storage group.

He received Masters in Electrical Engineering at the Technical University of Kosice ('85), Ph.D. from Delft University of Technology ('95) and title prof. from the president of Czech Republic at the Brno University of Technology (2008) and Delft University of Technology (2016).

From 2002 to 2003 he was working partially at KEMA (DNV GL, Arnhem) on different projects related to power electronics applications in power systems.

He published over 100 journal and over 350 conference papers in his field (with H factor Google scholar 36, Web of science 24), he is an author or co-author of 8 books, holds 6 international patents and organized several tutorials at the international conferences.

He has worked on many projects for industry concerning wind and wave energy, power electronic applications for power systems such as Smarttrafo; HVDC systems, projects for smart cities such as PV charging of electric vehicles, PV and storage integration, contactless charging; and he participated in several Leonardo da Vinci and H2020 EU projects as project partner (ELINA, INETELE, E-Pragmatic, Smart Charging, Metrology for Inductive Charging, Trolley 2.0) and coordinator (PEMCWebLab.com-Edipe, SustEner, Eranet DCMICRO). He is a Senior Member of the IEEE ('97), former chairman of Benelux IEEE Joint Industry Applications Society, Power Electronics and Power Engineering Society chapter, chairman of the Power Electronics and Motion Control (PEMC) council, member of the Executive Committee of European Power Electronics Association (EPE) and also member of international steering committee at numerous conferences.

International recognition and awards:

- Awards Most Significant Innovation in Electric Vehicles 2018
- Best Leonardo da Vinci EU Project 2011 E-pragmatic (E-learning and Practical Training of Mechatronics and Alternative Technologies In Industrial Community).
- Best Educational Tool Award: First Prize IEEE Annual Conference of IEEE Industrial Electronics Society IECON/ICELIE 2009
- Maxwell Prize from Faculty of EE Kosice in 2007

The cooperation with the Politehnica University Timișoara has started in 1993 with a TEMPUS project.



Over time he has been involved in several international research projects in which UPT has been a partner.

He supported the development of practice internships for UPT students at DC Systems, Energy Conversion & Storage Group.

Prof. Bauer has participated as a keynote speaker at the ISETC 2014 and 2018 International Symposium on Electronics and Telecommunications.

He is one of UPT's supporters and promoters at international meetings of teachers and researchers. For example, through his diligence, Romania has since 2018 a new member in the PEMC Council and efforts are being made for PEMC conference be held for the first time in Romania in 2022.



# HABILITATION THESIS



## EVOLUTION OF HABILITATION THESIS IN UPT 2014 - 2018

Habilitation (from Latin *habilis* "fit, proper, skillful") is the highest academic qualification a scholar can achieve by his or her own pursuit.

In this chapter we present the habilitation thesis supported by teachers from Politehnica University Timișoara, both at UPT and, also, at other universities.

The habilitation thesis are presented in chronological order, according to institution where they were sustained.

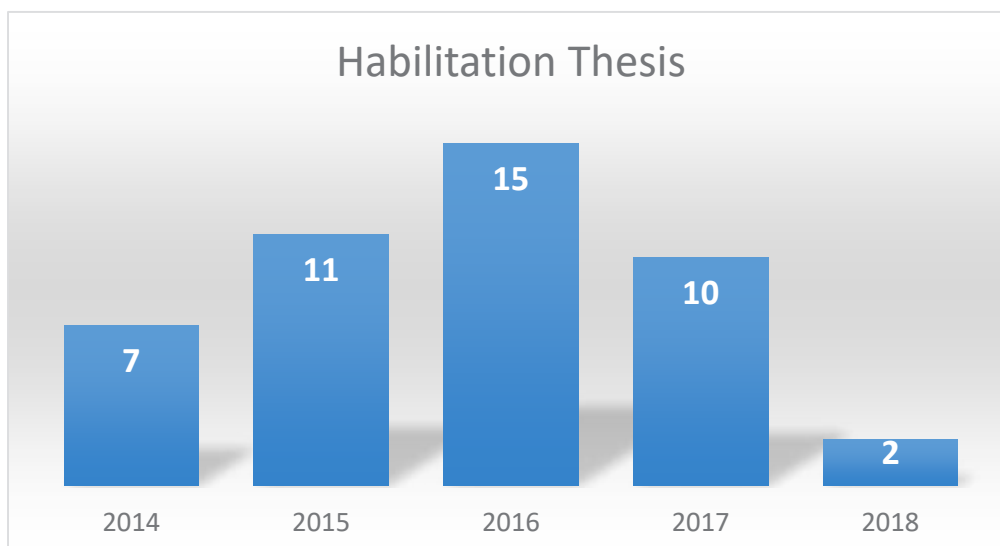



## NEW MATERIALS WITH APPLICATIONS IN CONSTRUCTIONS OF MICROBIAL FUEL CELLS AND THERMOELECTRICAL GENERATORS

**Author: Narcis Mihai DUȚEANU**

### Abstract

The habilitation thesis is structured in 2 parts. First part is shortly describing the main scientific, professional and academic achievements starting from the doctoral dissertation (March 2007) until today. Approached research domains were aiming chemical engineering and because of the approached thematic I can also state that I also targeted environmental protection domain.

Today's most important problem of the human society is the environment's incapacity of powering the growing global energy consumption – derived from industrial and household consumers. During the development of last century's society – electrical energy production and transport issues were noticed and tracked.

Starting from the classical fuel cells technology and correlating this technology with the necessity of advanced remediation of wastewaters, were developed the microbial fuel cells due to the discovery of microorganism able to use an external electrons acceptor. Microbial fuel cells represent electrochemical devices derived from classical fuel cells by replacing the platinum catalytic layers with biological catalytic layers. Due to this modification microbial fuel cells are able to convert organic matter from wastewaters directly into electrical energy concomitant with wastewater remediation.

For a better understanding of the actual development of microbial fuel cells technology I presented the working principle, and based on that it's been established the formula of calculating the tension at its terminals in ideal conditions.

Also, based on this formula – the possible losses occurring in the real functioning system have been evaluated – while explaining the way these losses can be minimized, pursuing the increase of the energy efficaciousness of the considered system.

Starting point of the research was a device cost reduction by



replacing the platinum catalyst layers with catalyst layers builds with carbonic materials – as also by replacing the protons exchange membranes with ceramic membranes.

Another research domain is the obtaining of semiconductors applicable in thermoelectric production systems of electrical energy. I considered this domain a priority because very big amounts of thermal energy are not used – therefore becoming residual energy.

During these experiments I synthesized and characterized the Zn<sub>4</sub>Sb<sub>3</sub> semiconductor as also research the way that Ag and Sn doping influence the properties of this material.

The second part of the habilitation thesis presents the planning and evolution of the teaching and research career. Thus, the future research directions are presented as a natural follow up of the research conducted so far.

All habilitation thesis at:

[http://www.upt.ro/Informatii\\_teze-de-abilitare-sustinute\\_285\\_ro.html](http://www.upt.ro/Informatii_teze-de-abilitare-sustinute_285_ro.html)

### Habilitation Commission

**Prof.univ.dr.ing. Corneliu – Mircea DAVIDESCU**

Politehnica University Timișoara

**Prof.univ.dr.ing. Dănuț-Ionel VĂIREANU**

University POLITEHNICA of Bucharest

**Prof.univ.dr.ing. Catinca SECUIANU**

University POLITEHNICA of Bucharest

## DEVELOPMENT OF NEW VARIANTS OF SYNTHESIS FOR SPINEL NANOSTRUCTURES WITH POTENTIAL APPLICATIONS IN ENVIRONMENTAL PROTECTION

Author: Marcela-Elena STOIA

### Abstract

This thesis synthetically presents the results obtained in the field of synthesis, characterization and environmental applications of nanostructured oxides systems.

The first part of this Habilitation Thesis presents the main professional, scientific and academic achievements obtained after granting the PhD title, as well as a selection and scientific results representative for my activity in the field of development of new variants of synthesis for spinel ferrite nanoparticles with potential environmental applications.

It is well known that the reduction in size of ferrite particles to nanometric scale leads to special properties for these materials, different from those of the bulk (micrometric) material. It has also been demonstrated that the chemical and magnetic properties of nanoparticles in general (and in particular spinel ferrites) are strongly influenced by their composition, structure and morphology, which, in turn, are dependent on the synthesis methodology. Hence the importance of developing new synthesis variants by modifying the already known synthesis methods so as to provide the most advanced control over the shape and size of nanoparticles and, implicitly, over their properties. In this context, my research activities on the development of new synthesis variants, focused on four of the synthesis methods employed to obtain nanocrystalline spinel ferrite: the thermal decomposition of the precursors, the solvothermal method, the coprecipitation method and the sol-gel method.

Thus, in the case of the method based on the thermal decomposition of the precursors obtained in the redox reaction between the mixture of nitrates and diols, I have expanded the research by using polyols as reducing agents, such as high molecular weight polyvinyl alcohol.

An important chapter included in the scientific part of this

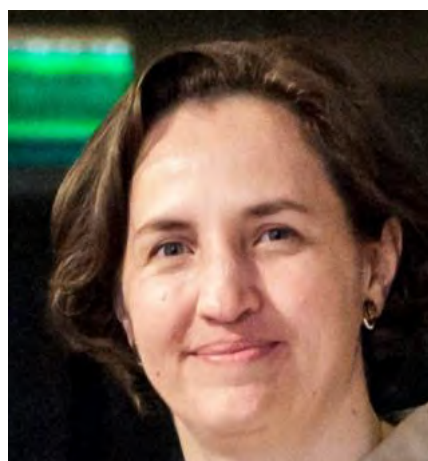

thesis is the testing of MFe<sub>2</sub>O<sub>4</sub>/active carbon composites (M = Fe(II), Mn(II)) for the removal of organic pollutants (phenol, organic dyes) from water. These composites combine the high specific surface area of the activated carbon (which gives the composites high adsorption capacity) with the magnetic properties of ferrite nanopowders, which ensure a simple separation of the composite from the suspension. The second part of this thesis presents the evolution and development plan of the professional, scientific and academic career, the proposed objectives and the future research directions.

The full thesis at:

[http://www.upt.ro/img/files/2016-2017/abilitare/stoia/Stoia\\_Marcela\\_Teza\\_abilitare.pdf](http://www.upt.ro/img/files/2016-2017/abilitare/stoia/Stoia_Marcela_Teza_abilitare.pdf)

### Habilitation Commission

**Prof.univ.dr.ing. Cornelia PACURARIU**

Politehnica University Timișoara

**Prof.univ.dr.ing. Adelina-Carmen IANCULESCU**

University POLITEHNICA of Bucharest

**Prof.univ.dr.ing. CS1 Gheorghe ILIA**

Institute of Chemistry of Romanian Academy - Timișoara Branch

# PhD THESIS





## EVOLUTION OF PhD THESIS DEFENDED IN UPT 2014 - 2018

PhD students of UPT are those with a high degree of personal motivation that stems from their natural curiosity and love of intellectual pursuits. It is expected that after they obtain their degree they will metamorphose into scholars for whom also the temptation of researching new and exciting subjects is irresistible, or at least preferable to all other choices.

Doctoral programs usually encompass intensive training in research methods, including interviewing, surveys, questionnaires, clinical trials and laboratory experiments; later, those skills are put into practice when the doctoral candidate conducts fieldwork for his dissertation. Skills gained in qualitative and quantitative research methodology and statistical analysis are transferable to non-academic research environments, particularly for industrial research. In addition, employers outside of academia seek individuals with sound research skills to carry out projects at think tanks and research institutes in both the private and government sectors.

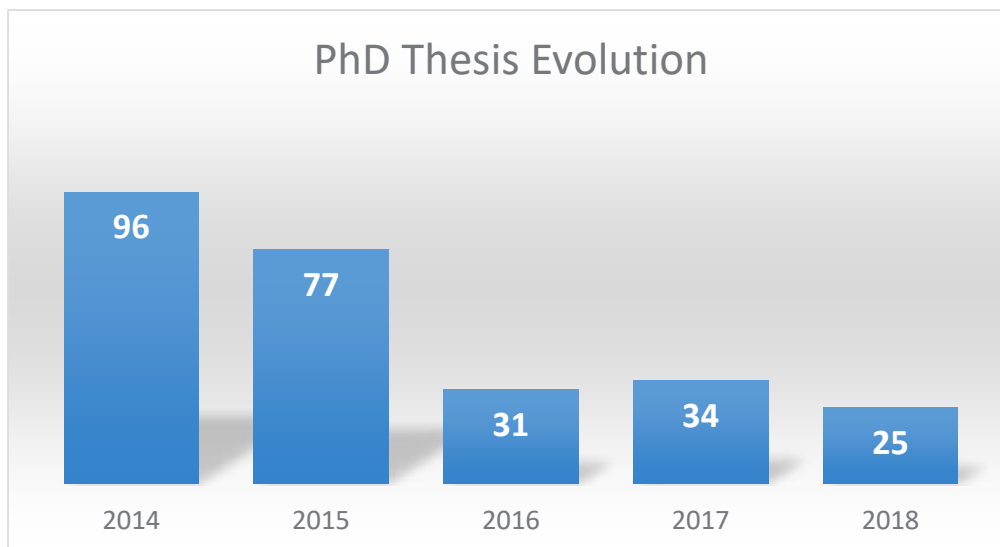

In this chapter we present a list of the PhD Thesis defended in Politehnica University Timisoara during 2018.



## Computers and Information Technology

<b>Oana Sorina LUPȘE</b> PhD adviser prof. L. STOICU-TIVADAR	<i>Soluții flexibile pentru continuitatea serviciilor medicale</i> (Providing flexible solutions for continuous services (SEAMLESS) in healthcare )
<b>Andrei STANCOVICI</b> PhD adviser prof. V.I. CREȚU	<i>Metodologie de localizare relativă în medii colaborative robotizate</i> (Relative Localization Methodology in Collaborative Robotic Environments)
<b>Ovidiu SICOE</b> PhD adviser prof. M. POPA	<i>Generarea de micro-operații de virgulă flotantă utilizate în grafică, implementare pe FPGA</i> (Generation of floating-point micro-operations used in graphics, implemented with FPGAs)

## Systems Engineering

<b>Raul-Cristian ROMAN</b> PhD adviser prof. R.E. PRECUP	<i>Tehnici de tip model-free de acordare a parametrilor reguletoarelor automate</i> (Model-free techniques for tuning the parameters of automatic controllers)
---	---

## Civil Engineering and Building Services

<b>Ciprian-Ionuț ZUB</b> PhD adviser Acad. D. DUBINĂ	<i>Protecția antisismică a structurilor în cadre cu contravântuiri cu flambaj împiedecat</i> (Seismic protection of building framed structures with Buckling Restrained Braces)
<b>Eleonora Eva PARTENE</b> PhD adviser prof. V. STOIAN	<i>Studiul comportării pereților din zidărie la încercări seismice. Consolidarea pereților din zidărie cu materiale polimerice</i> (Studies concerning the behaviour of masonry walls under seismic actions. Strengthening of masonry walls using composite materials)
<b>Bogdan-Grigore BRĂNIȘTEANU-ALBULESCU</b> PhD adviser prof. I.A:N. RETEZAN	<i>Studiul prevenirii și stingerii incendiilor prin cunoașterea caracteristicilor de declanșare, evoluție și funcționare a mijloacelor de stingere</i> (Fire prevention and suppression study regarding activation, evolution and functioning characteristics of fire safety systems)
<b>Cristina-Mariana TĂNASĂ</b> PhD adviser prof. V.A. STOIAN	<i>Studiul eficienței energetice a clădirilor utilizând simulări numerice și măsurători in site</i> (Study on building energy efficiency using numerical simulations and in situ measurements)
<b>Iosif Ciprian BALAJ</b> PhD adviser prof. T.E. MAN	<i>Posibilități de utilizare a energiei solare în amenajările de îmbunătățiri funciare</i> (Possibilities of using solar energy in land improvementss)
<b>Mihaela Ileana BERECHET</b> PhD adviser prof. I. MIREL	<i>Evaluarea ecologică a sistemelor de gestionare a deșeurilor menajere în țări ale uniunii europene</i> (Ecological evaluation of waste management systems from some EU countries)

## Engineering and Management

<b>Gabriela ANTAL (căs. FISTIȘ)</b> PhD adviser prof. A. DRĂGHICI	<i>Sustenabilitatea sistemelor organizaționale - un posibil model strategic</i> (Organizations systems sustainability - a possible strategic model)
<b>Simona IVAȘCU (RUS)</b> PhD adviser prof. M.L. MOCAN	<i>Strategie de dezvoltare pentru bănci în urma crizei economico-financiare</i> (Advanced electrochemical (Banking development strategy following the economic and financial crisis)
<b>Cristina BUNGET (căs. BORCA)</b> PhD adviser prof. A. DRĂGHICI	<i>Rolul comunicării organizaționale în percepția dimensiunilor responsabilității sociale</i> (The role corporate communication in the perception of social responsibility's dimensions)

## Materials Engineering

<b>Darius-Alexandru POPESCU</b> PhD adviser prof. T. HEPUȚ	<i>Cercetări privind valorificarea deșeurilor pulverulente și mărunte din industria metalurgică</i> (Research on the use of powdery and fine ferrous waste from metallurgy industry)
<b>Andrei Lucian CRĂCIUN</b> PhD adviser prof. T. HEPUȚ	<i>Cercetări privind utilizarea materialelor compozite la sistemele de frânare ale autovehiculelor</i> (Research on the use of composite materials in vehicle braking systems)
<b>Dan MĂLĂESCU</b> PhD adviser prof. I. GROZESCU	<i>Studiul proprietăților electrice ale materialelor ceramice de tip NaTaO<sub>3</sub> cu structură perovskitică</i> (The study of the electrical properties of ceramic materials NaTaO <sub>3</sub> type with perovskitic structure)
<b>Csaba-Attila GHEORGHIU</b> PhD adviser prof. T. HEPUȚ	<i>Îmbunătățirea procesului de răcire secundară a semifabricatelor din oțel turnate continuu</i> (Improvement of the secondary cooling process of continuously cast steel)
<b>Letiția-Roma CÂNDA</b> PhD adviser prof. T. HEPUȚ	<i>Cercetări privind recuperarea argintului din filme radiografice și efluenți</i> (Research on the recovery of silver from radiographic films and effluents)

## Industrial Engineering

<b>Alexandru FILIPOVICI</b> PhD adviser prof. D. ȚUCU	<i>Posibilități de optimizare a tehnologiilor industriale de valorificare a biomasei prin piroliză</i> (Optimisation possibilities for industrial technologies of biomass valorisation through Pyrolysis)
--	--

## Mechanical Engineering

<b>Daniel Vasile ACHIRILOAIEI</b> PhD adviser prof. I. DUMITRU	<i>Influența factorilor constructivi și funcționali asupra rezistenței mecanice la solicitări statice și variabile a conductoarelor de înaltă tensiune</i> (On the influence of constructive and functional factors concerning mechanical resistance on static and variable stresses of high voltage conductors)
<b>Doru CONSTANTIN</b> PhD adviser prof. M. NAGY	<i>Studii și cercetări îmbunătățirea unor parametri de confort în sisteme de transport</i> (Studies and research on comfort parameters improvement in transport systems)
<b>Lucia Ana PUP (căsătorită Varga)</b> PhD adviser prof. I. IONEL	<i>Contribuții privind valorificarea energetică a biomasei pentru obținerea de biogaz</i> (Contributions to energy recovery from biomass for biogas production)

**Andrei Zoltan FARKAȘ**  
PhD adviser prof. I. MANIU

*Determinarea diferențelor posturale dintre diferite ramuri sportive*  
(Determination of postural differences between different sports branches)

**Roxana IVAN**  
PhD adviser prof. I. IONEL

*Cercetări privind prognoza emisiilor pentru principalele gaze cu efect de seră*  
(Comparative analysis of some forecasting methodologies for greenhouse gas emissions projections)

## Power Engineering

**Flaviu DILERTEA**  
PhD adviser prof. F.D. ȘURIANU

*Optimizarea funcționării sistemului hidrogenerator de la Centrala Hidroelectrică Râul Mare Retezat*  
(Optimization of the operation of hydrogenerator system at Râul Mare Retezat Hydroelectric Power Plant)



# SCIENTIFIC CONFERENCES





EVOLUTION OF SCIENTIFIC CONFERENCES  
2014 - 2018

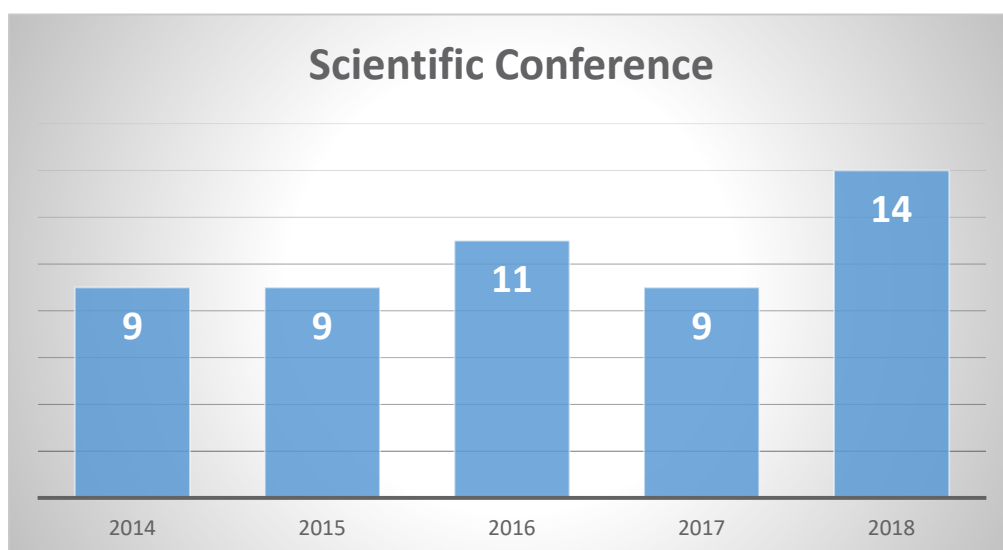





## Building Services and Environmental Comfort (ICCA 2018)

March 22 - 23, 2018, Timișoara, Romania

**Organizers:** AIIR - Romanian Association of Building Services - Timișoara Chapter, Politehnica University Timișoara - Civil Engineering and Installations Department, in association with REHVA, Danube ASHRAE Chapter, Research Center of Installations, Electrical Installations and Automation Society Romania

<http://www.aiir-timisoara.ro>

The essential issues of human existence, such as environmental protection, energy consumption reduction, environmental comfort, are found in the 29 papers of the conference volume as well as in the 18 scientific papers presented by the country's specialists and foreigners in the plenary.

At the conference proceedings have contributed 91 specialists who addressed topics such as air and water quality, the use of unconventional energies (solar energy, wind energy, ground energy and energy of the environment), technical sustainability, but also the influence / importance of human action in contact with the environment.

Publication of papers:

The volume consisting of the conference's papers was published by MATRIX ROM Bucharest Publishing (ISSN: 1842-9491).



## 7<sup>th</sup> International Conference on Advanced Materials and Structures AMS'18

March 28 - 31, 2018, Timișoara, Romania

**Organizers:** Department of Materials Engineering and Manufacturing and Department of Mechanics and Strength of Materials in collaboration with the Politehnica Foundation

[www.ams.upt.ro](http://www.ams.upt.ro)

The conference Advanced Materials and Structures (AMS'18) was held between 28 to 31 March 2018 at Timișoara, Romania and it is the seventh edition of the scientific event organized by the Department of Materials Engineering and Manufacturing and Department of Mechanics and Strength of Materials in collaboration with the Politehnica Foundation.

The conference topics included:

- Advanced materials (amorphous, nano-structured materials, composites, cellular materials, biomaterials, etc.);
- Surface engineering;
- Modern fabrication, joints and recycling technologies;
- Materials damage under time-dependent-actions (fatigue, creep, impact, corrosion);
- Computational techniques for advanced engineering materials and structures.

Publication of papers:

Proceeding of AMS'18 was published as separate edition in IOP Conference Series: Materials Science and Engineering (MSE), Volume 416(1).

MSE is an open-access proceedings and conference papers journal published online as a single volume. It is indexed in ISI Web of Science (Conference Proceedings Citation Index), Scopus, Ei Compendex.



## International Conference on Applied Sciences ICAS2018

May 9 - 11, 2018, Banja Luka, Bosnia and Herzegovina

**Organizers:** Politehnica University Timișoara and Unieversity of Banja Luka in cooperation with Ministry of Science and Technology of the Republic of Srpska, Bosnia and Herzegovina  
Ministry of Trade and Tourism of the Republic of Srpska, Bosnia and Herzegovina  
Academy of Romanian Scientists  
Academy of Sciences of the Republic of Srpska, Bosnia and Herzegovina  
Academy of Technical Sciences of Romania - Timisoara Branch  
and General Association of Romanian Engineers - Hunedoara Branch

<http://www.fih.upt.ro/v4/ICAS2018/index.htm>

The conference has been focused on several fields of application, operation and influence of the applied sciences and technologies on industry. Topics of the conference covers a comprehensive spectrum of issues from:

1. *Materials Science:* Metallic Materials, Composite Materials, Metal Alloys, Metallurgy, Heat Transfer, and others...
2. *Mechatronics:* Mechanical Engineering, Robotic Systems Engineering, Control Engineering, Reliability, and others...
3. *Electrical Engineering:* Circuits and Systems, Signal Processing, Electric Motors, and others...
4. *Computers Engineering:* Modeling and Simulation, Computational Methods in Engineering, Software Engineering, Data Bases, and others...
5. *Fundamental Sciences:* Numerical approximation and analysis, Interdisciplinary applications of mathematics and physics, Chemistry, and others...

The conference gathered qualified researchers whose expertise can be used to develop new engineering knowledge that has applicability potential in Industry.

Publication of papers: Proceedings of ICAS2018 published in *IOP Conference Series: Materials Science and Engineering vol. 477* (2019), indexed by *Thomson Reuters - Web of Sciences* (Conference Proceedings Citation Index) and *Scopus*.

SACI 2018  
May 17-19, 2018



## IEEE 12<sup>th</sup> International Symposium on Applied Computational Intelligence and Informatics (SACI 2018)

May 17 - 19, 2018, Timișoara, Romania

**Organizers:** Óbuda University, Budapest, Hungary, Politehnica University Timișoara, IEEE Chapter of Systems, Many, and Cybernetics Society, Romania

<http://conf.uni-obuda.hu/saci2018/>

SACI 2018 has featured several kinds of presentations, including invited talks, contributed papers and posters. The outcome of SACI 2018 is a better understanding of some leading research areas, as already Computational Intelligence and Informatics have demonstrated.

SACI 2018 has welcomed papers on the following topics:

- Computational Intelligence
- Intelligent Mechatronics
- Systems Engineering
- Intelligent Manufacturing Systems
- Intelligent Control
- Intelligent Robotics
- Informatics.

Publication of papers:

IEEE Xplore Digital Library, please visit <http://ieeexplore.ieee.org/search/searchresult.jsp?newsearch=true&queryText=SACI%202018>



## 4<sup>th</sup> International Workshop on Open Educational Resources and Massive Open Online Courses (part of the 14<sup>th</sup> eLearning and Software for Education Conference - eLSE 2018)

May 19 - 20, 2018, Timișoara, Romania

**Organizers:** Carol I National Defence University and European Security and Defence College (ESDC),  
"Ioan Slavici" University of Timișoara, West University of Timișoara,  
Politehnica University Timișoara, Vasile Alecsandri University of Bacau

[https://www.elseconference.eu/pages/view?page=open\\_education\\_open\\_online\\_courses](https://www.elseconference.eu/pages/view?page=open_education_open_online_courses)

The primary goal of the workshop is to bring together educational actors and stakeholders as teachers, trainers, technologists, researchers, course designers, doctoral students in the fields of new technologies, pedagogies and policies related to Open Education, Open Educational Resources (OERs) and Massive Open Online Courses (MOOCs) in order to share knowledge, approaches, strategies, models, solutions and applications in an educational context.

The workshop's topics include (but are not limited to):

- Open education - the meaning of open: open access, open scholars, open educators, open learning, open science, open data
- Open pedagogy and open educational practices (OEPs)
- The economics of open education
- Issues at the intersection of open and assessment
- Tools and technologies supporting open education
- Collaborations in support of open education
- OERs/MOOCs: policy and systemic impact (open policies)
- Good practices of using OERs and MOOCs in HE / Adult Education (digital literacies, skills, pedagogy)
- Platforms for MOOC hosting
- Strategies/Models for MOOCs: video/content creation, facilitation, assessment, student motivation, quality assurance, certification and accreditation, open badges
- MOOCs and personalized learning
- MOOCs and flipped classrooms/blended learning
- Business models for MOOCs etc.

Published papers by: "CAROL I" National Defence University Publishing House, Index WOS, Thomson Reuters, CEEOL, PROQUEST, EBSCO



## 1<sup>st</sup> International Conference on Computational Methods and Applications in Engineering

May 23 - 26, 2018, Timișoara, Romania

**Organizers:** Mississippi State University, USA  
Politehnica University Timișoara, Romania

<http://icmae.elearning.upt.ro/>

The objectives of this conference are to enhance interdisciplinary international work between scientists and engineers in USA and Romania. One particular goal is to further expand the established collaboration between organizing institutions.

In addition to plenary lectures, there will be sessions for mini-symposia and contributed talks.

The main topics are, but not limited to:

### *Track 1: Applied/Computational Mathematics*

- Fractional Calculus
- Image Processing
- Mathematical Biology
- Optimal Control
- Differential Equations and their Numerical Methods

### *Track 2: Computational Methods in Mechanical Engineering*

- Applied mathematics and Mechanics
- Applied Thermodynamics
- Applied Analytical and Numerical Material Modelling

- Computational Fluid Dynamics

### *Track 3: Applications in Information Technologies*

- Open Data Applications
- Applied Statistics and Big Data Analytics
- Smart Cities Applications
- Integrated Infrastructures and Processes for Smart Cities
- eScience and the Information Society
- Virtual and Augmented Reality

Publication of papers: The final revised and accepted papers will be published as open-access papers in a dedicated volume on the ITM Web of Conferences (<http://www.itm-conferences.org>).

## ICNcT 2018

### 19<sup>th</sup> International Conference of Nonconventional Technologies – ICNcT 2018

October 4 – 6, 2018, Timisoara, Romania

**Organizers:** Academy for Technical Sciences of Romania  
Romanian Association for Nonconventional Technologies  
Politehnica University Timișoara  
“Lucian Blaga” University Of Sibiu

<http://www.artn.ro/conference2018/>

The conference is part of the most representative global scientific manifestations' gallery of its kind and has a 47-year-old tradition in the scientific world. The 2018 19<sup>th</sup> edition subscribes to the current context in which nanotechnologies are the future of the planet and their importance in the economic development of regions is heavily considered.

Conference topics:

- Basic physical phenomena and processes of the nonconventional processing procedures;
- Machineries and equipment for non-conventional processing;
- Experimental Research and Nonconventional Processing Technologies
- Nonconventional technologies management and other nonconventional processes

Publication of papers: The papers presented during the Conference are published in „Nonconventional Technologies Review”, ([www.revtn.ro](http://www.revtn.ro)) scientific publication established in 1997 with quarterly issuing, B+ Review, indexed in international data bases: Copernicus, ProQuest, EBSCO, Google Scholar and under indexation in more international data bases. (ISSN/ISSN-L 2359-8646)



### Conference on Ulam's Type Stability (CUTS)

October 8 – 13, 2018, Timișoara, Romania

**Organizers:** Department of Mathematics of Politehnica University Timișoara  
in cooperation with

Department of Mathematics of Pedagogical University of Cracow, Poland

Faculty of Applied Mathematics of AGH University of Science and Technology (Cracow, Poland)

<https://cuts.up.krakow.pl/2018/>

The conference is devoted to various investigations connected with the notion of stability, motivated by the well-known problem of S. Ulam, on the approximate homeomorphisms of metric groups, and related issues.

The participants were invited to give talks on:

- stability of difference, differential, functional, and integral equations,
- stability of inequalities and other mathematical objects,
- hyperstability and superstability,
- various (direct, fixed point, invariant mean, etc.) methods for proving Ulam's type stability results,
- generalized (in the sense of Aoki and Rassias, Bourgin and Găvruta) stability,
- stability on restricted domains and in various (metric, Banach, non-Archimedean, fuzzy, quasi-Banach, etc.) spaces,
- relations between Ulam's type stability and fixed point results,
- related topics.

Moreover, some special invited plenary lectures were been given.



## 22<sup>nd</sup> International Conference on System Theory, Control and Computing (ICSTCC 2018)

October 10 - 12, 2018, Sinaia, Romania

**Organizers:** Faculty of Automation, Computers and Electronics of University of Craiova; Faculty of Automatic Control and Computer Engineering of Gheorghe Asachi Technical University of Iasi; Faculty of Control Systems, Computers, Electrical and Electronics Engineering of "Dunarea de Jos" University of Galati; Faculty of Automation and Computers, Department of Automation and Applied Informatics and Department of Computers and Information Technology of Politehnica University Timișoara

<http://www.icstcc.ugal.ro/2018/>

ICSTCC 2018 has featured several kinds of presentations, including invited talks, contributed papers, posters and special sessions. The outcome of ICSTCC 2018 is a better understanding of some leading research areas, as already System Theory, Control and Computing have demonstrated.

ICSTCC 2018 has welcomed papers on the following topics:

- Automation and Robotics: Linear and Nonlinear Control System Design, System Identification and Process Modeling, Robust and Adaptive Control, Robotics and Intelligent Control, Applications and Case Studies in Automation and Robotics, Embedded Systems;
- Computer Science and Engineering: Distributed Systems and Software Engineering, Databases, Systems of Programs and Expert Systems, Web services, Internet Security, Software Tools and Methods, Grid Computing, Artificial Intelligence, Computer Architectures;
- Electronics and Instrumentation: Modeling, Simulation and CAD Tools, Signal Processing and Communication Systems, Linear and Nonlinear Circuits and Systems, Evolutionary Electronics.

Publication of papers:

IEEE Xplore Digital Library, please visit <http://ieeexplore.ieee.org/search/searchresult.jsp?newsearch=true&queryText=ICSTCC%202018>



## Aquademica 2018 Conference

**Water Management in the context of climate change. International experiences.**

October 11 - 12, 2018, Central Library of the Politehnica University Timișoara, Romania

**Organizers:** Aquademica Foundation, Aquatim, Romanian Water Association and Politehnica University Timișoara

<http://conferinta.aquademica.ro/>

Aquademica International Scientific Conference continues the tradition of the previous Eco-Impuls Conference, and in 2018 year it was held at the Library of Politehnica University Timișoara in Romania.

Conference topics:

- Water technology
- Economical and legal aspects of water management
- Water management under the climate change

Aquademica 2018 Conference enables researchers, students and other specialists to participate with full papers reflecting their recent research results convergent with the conference theme. Authors were invited to publish the papers that describe novel ideas and technologies, applications, experiments and empirical studies or design techniques within topics of the conference.

Accepted papers were included in conference digital edition and published in the following journals:

- Aquademica Journal
- Chemical Bulletin of Politehnica University Timișoara, Abstracted/indexed in Index Copernicus, Directory of Open Access Journals, Electronic Journals Library, VINITI, Chemical Abstracts Plus, Ulrich's Periodicals.
- Scientific Bulletin of the Politehnica University Timișoara, Transactions on Engineering and Management
- Scientific Bulletin of the Politehnica University Timișoara, Transactions on Hydrotechnics

## ICMA 2018

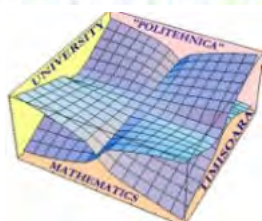

### The 15<sup>th</sup> International Conference on Mathematics and its Applications - ICMA 2018

November 1 - 3, 2018, Central Library of the Politehnica University Timișoara, Romania

**Organizers:** Department of Mathematics - Politehnica University Timișoara  
Romanian Academy - Timisoara Branch

[http://www.mat.upt.ro/Informatii\\_141\\_ro.html](http://www.mat.upt.ro/Informatii_141_ro.html)

The main aim of the Conference was to facilitate the exchange of knowledge and of new results in the field of mathematics and its applications in various other fields of study. We hope that the Conference has provided invaluable opportunities for fruitful contacts between participants from Romania and from abroad.

The lectures presented at ICMA 2018 were included in three sections:

1. Mathematical analysis and applications,
2. Algebra and Geometry, Computer Algebra Systems in research and
3. Applied Mathematics in Engineering and Economics, Probability and Statistics in Health and Clinical Research.

The lectures presented at ICMA 2018 belong to a variety of topics reflecting the concern of various research teams and/or fields.

Published papers by:

Selected papers were published by Politehnica Publishing House in the volume *ICMA 2018 - The 15th International Conference on Mathematics and its Application*, ISSN 1224 - 6069 and in the *Scientific Bulletin of the Politehnica University Timișoara, Transactions on Mathematics and Physics*. Languages of publication: English.



### 13<sup>th</sup> International Symposium on Electronics and Telecommunications (ISETC18)

November 08 - 09, 2018, Timișoara, Romania

**Organizers:** Faculty of Electronics, Telecommunications and Information Technologies,  
Politehnica University Timișoara;  
Association of Electronics and Telecommunication Engineering from Timișoara.

<http://conference.etc.upt.ro/isetc2018/>

Technical sponsors

- IEEE Romania
- Joint Chapter Communications/IEEE Information Theory/Signal Processing Societies
- ASTR - Romanian Academy of Technical Sciences

This year's conference consists of two plenary sessions and 14 regular parallel sessions, where 79 papers, written by 192 authors from 7 countries, were presented.

Main track were:

1. Intelligent Electronic Systems
2. Telecommunications
3. Signal Processing
4. Education & Learning Technologies

Other activities

1. Workshop - Satellite Communication - The Backhauling for Mobile next generation, room MULTIMEDIA 2
2. IEEE Young Professionals Group Meeting  
November 09
3. Honorary professor awarding ceremony -  
Prof. Ph.D. Pavol Bauer

Publication of papers:

The Conference proceedings could be found on **Web of Science**, **eXplore** data bases (IEEE) and **SCOPUS**



INTERNATIONAL CONFERENCE  
„GLOBAL and REGIONAL  
in ENVIRONMENTAL PROTECTION”  
**GLOREP 2018**

### Global and Regional in Environmental Protection (GLOREP2018)

November 15 – 17, 2018, Conference Center of the Politehnica University Timișoara, Romania

**Organizers:** Politehnica University Timișoara,  
in cooperation with the West University of Timisoara, University of Petrosani,  
and University of Agricultural Sciences and Veterinary Medicine of Banat *‘King Mihai I of Romania*,  
under the auspices of the Balkan Environmental Association (BENA) and the Politehnica Foundation.  
<http://glorep.upt.ro/>

The event was dedicated to the celebration of the Centenary of Romania and was associated with an artistic program organized by students and the famous painter Mihai Teodor OLTEANU from Timisoara, completed by exhibition homage panels dedicated to the one who defeated the gravity, the inventor Traian VUIA put at the disposal of the Banat Museum. It was devoted to global and regional environmental issues, being part of the BENA conferences, hosted annually in the Balkan -space, focusing on specific environmental issues and concerns. The event also marked the 98<sup>th</sup> anniversary of the birth of the Politehnica University Timișoara, by King Ferdinand, in November 1920.

The event included several scientific sections in which scientists from Romania and abroad (Albania, Canada, Croatia, Cameroon, Macedonia, Greece, Germany, Serbia, Slovakia, Hungary, Turkey, China, Iran, ) presented large-scale works and will debated themes in the fields of following main TOPICS:

- environmental management and sustainable development,
- public health impact,
- climate change and environmental risk assessment,
- renewable energy resources and technologies,
- air, water and soil quality,
- urban planning,
- environmental education and public awareness

Publication of papers: <https://glorep.upt.ro/resource/Glorep2018.pdf>;

Publisher: Politehnica Printing House, Timisoara, 2018, ISBN 978-606-35-0385-5

**COHESION**  
CONFERENCE ON HERITAGE AND SUSTAINABLE INNOVATION

### International Conference on Heritage and Sustainable Innovation - CoHeSION

November 17, 2018, Central Library of the Politehnica University Timișoara, Romania

**Organizer:** Faculty of Architecture and Urban Planning, Politehnica University Timișoara  
<http://cohesion.ro/index.html>

Heritage can be a base for identity, integrity and “spirit of place”, value, individuality, emotion and can play an important role in ensuring social cohesion and welfare. Understanding heritage and its contribution to social and urban development needs to be done from a multidisciplinary perspective. As an integral factor of sustainable development heritage promotes a high quality of life through cultural values. It also reinforces unity and diversity, bringing citizens together, while enhancing the uniqueness of communities and individuals. Considering that 2018 was the European Year of Cultural Heritage, the first edition of the International Conference on Heritage and Sustainable Innovation – CoHeSION, was organized by the Faculty of Architecture and Urban Planning. 28 papers were presented at the conference, by international and national authors. Architect and member of the European Parliament, Daniela Aiuto was the keynote speaker. The CoHeSION conference offers an important platform for researchers, architects, engineers and other specialists to present and discuss a wide variety of topics related to the protection of historical heritage:

- Theories, research, documentation, historical studies: presentation of sites, elements, contents and contenders for whom heritage is a key factor.
- Urban strategies: sites presentation and initiatives with the purpose of urban heritage and landscapes development.
- Heritage management: management of establishments, sites, assemblies and individual buildings; interaction with actors; economic, legal, administrative, political, cultural, fiscal and environmental contexts.
- Technology and techniques: available technologies for restoration, conservation and rehabilitation as one of the most important steps in dealing with heritage.
- Interior design heritage: restoration, conservation and rehabilitation of existing historical buildings.

Publication of papers:

Accepted papers after review were published in the “Journal of Architecture, Urbanism and Heritage” (ISSN 2668-2249), a peer-review academic journal which publishes original research papers and advances theory, research and practice in the fields of architecture and urban planning.



# SCIENTIFIC JOURNALS





## Transactions on Engineering and Management Volume 4, Issue 1, 2018

[www.mpt.upt.ro/cercetare/buletin-stiintific.html](http://www.mpt.upt.ro/cercetare/buletin-stiintific.html)

- The Scientific Bulletin of Politehnica University Timișoara, Transaction on Engineering and Management presents research results in the field of industrial management and business studies that are of significant impact on major contemporary issues.
- The journal welcomes submissions of theoretical, methodological, empirical, policy-oriented, as well as industrial papers in all the field. Additionally, it considers contributions that combine engineering and management studies with any other field of inquiry.
- SCIENTIFIC BULLETIN of Politehnica University Timișoara, Transactions on ENGINEERING AND MANAGEMENT is indexed: Index Copernicus, Google Scholar (under review), Ulrich (under review).



## Transactions on Hydrotechnics Volume 63 (77), Issue 1, Issue 2, 2018

<http://www.ct.upt.ro/buletinhidro/index.htm>

- The Scientific Bulletin of the Politehnica University Timișoara, Transactions on Hydrotechnics is coordinated since 1992 by the Faculty of Hydrotechnical Engineering. Published papers in the journal focus on engineering sciences, civil engineering, theoretical and applied hydraulic, mathematics and numerical modeling, hydrology and water management, hydrotechnical developments and constructions, land improvement (irrigations, drainage, erosion control), engineering and sustainable rural development, water supply and sewerage systems, wastewater treatment, hydraulic structures and technologies.
- The Journal is published entirely in English, with abstracts and keywords, with international exposure.
- The revue is known for experts from home and abroad, is included in the database (Viniti, Russia) and international catalogs (SUWECO, Czech Republic). The Bulletin is broadcast in 26 foreign institutions and foreign publications received in exchange are in number of 19.



## Transactions on Mathematics and Physics Volume 63 (77), Issue 1, 2018

[www.upt.ro/Informatii\\_seria-matematica\\_294\\_ro.html](http://www.upt.ro/Informatii_seria-matematica_294_ro.html)

- The journal "Bulletin Scientifique de l'Ecole Polytechnique de Timisoara" was founded in 1923, when the head of the Polytechnical School of Timisoara was mathematicians Victor Vâlcovici (1885-1970).
- The first two issues appeared in 1925, respectively in 1926. In the first years, the journal has been contained mostly the mathematical articles (the authors being some famous national and foreign mathematicians as well V. Alaci, G. Alexich, M. Ghermănescu, D. Pompeiu, Ch. Brunold, G. Bouligand). This fact confer to actual journal "Transactions on Mathematics and Physics" of the Scientific Bulletin of Politehnica University Timisoara, Romania the justification to realize the continuity of the old "Bulletin Scientifique".
- The **Transactions on Mathematics and Physics** is indexed CNCISIS, B+.



## Transactions on Modern Languages Volume 17, Issue 1, 2018

[www.sc.upt.ro/ro/publicatii/buletinul-stiintific/about](http://www.sc.upt.ro/ro/publicatii/buletinul-stiintific/about)

- The Transactions on Modern languages, published by the Department of Communication and Foreign Languages, has its origin in The Social Science and Humanities Series, started in 1991 under ISSN 1223-1959.
- The Transactions of Modern Languages publishes original papers in all areas of theoretical and applied linguistics: Linguistics, Translation and Interpreting Studies, Discourse Analysis, Pragmatics, Rhetoric, Terminology, LSP, Foreign Language Teaching.
- The journal is included in the CEEOL, Fabula and EBSCO data bases.

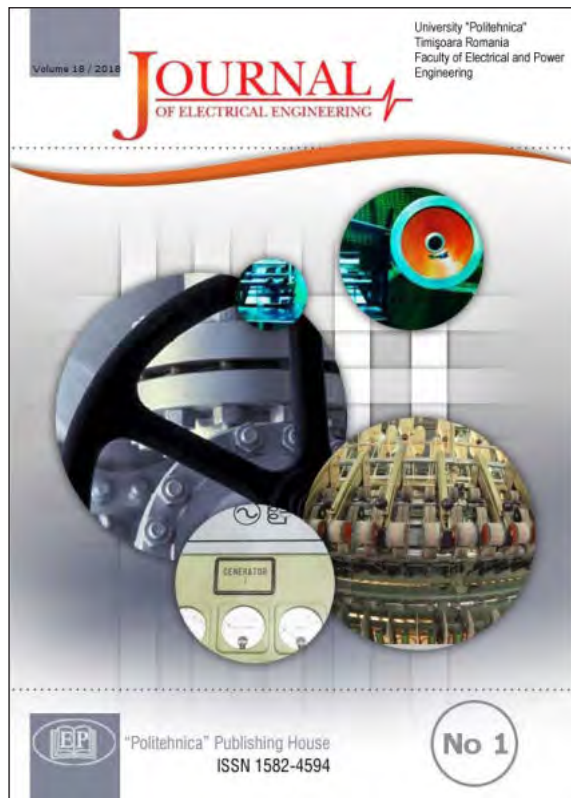

**Journal of Electrical Engineering**  
Volume 18, Issue 1, Issue 2, Issue 3, Issue 4, 2018

[www.jee.ro/](http://www.jee.ro/)

- JEE continues the prestigious "Scientific Bulletin" of the Politehnica University Timișoara, Electrotechnical section, but in electronic form.
- It also aims to become a fully international archival journal.
- Its scope includes all issues of widespread generic interest to engineers who work in the field of electrical engineering.
- The **Journal of Electrical Engineering** is indexed by Scopus and IEE INSPEC.

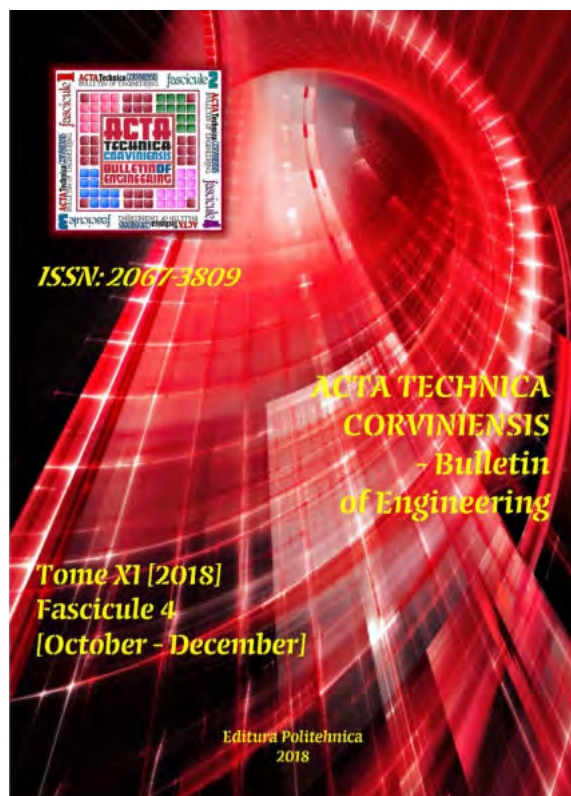

**Acta Technica Corviniensis - Bulletin of Engineering**  
Volume 11, Issue 1, Issue 2, Issue 3, Issue 4, 2018

<http://acta.fih.upt.ro/>

- ACTA TECHNICA CORVINIENSIS - Bulletin of Engineering is an independent, free-access, online, international and multidisciplinary scientific publication edited by the Politehnica University Timișoara, Faculty Engineering Hunedoara and Faculty of Mechanical Engineering Timișoara.
- The Journal is focused on engineering sciences and other innovative allied research areas, in all fields of science and technology on the basis of its originality, importance and timeliness.
- ACTA TECHNICA CORVINIENSIS - Bulletin of Engineering is accredited and ranked in the "B+" CATEGORY Journal by CNCIS, and is indexed by Index Copernicus, Google Scholar, EBSCO Publishing, DOAJ, SCIRUS, Evisa, ProQuest, DRJI, CAS, BASE, ULRICHswab - Global serials directory, Directory Indexing of International Research Journals, Electronic Journals Library etc.

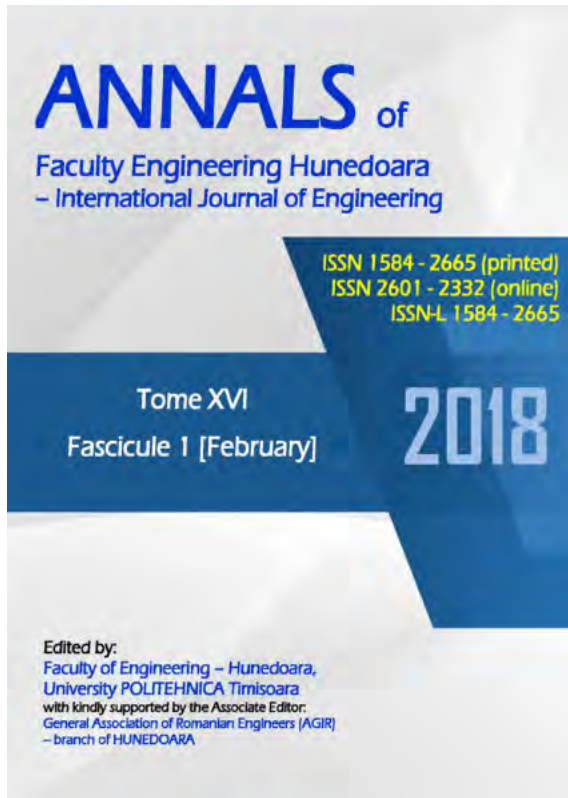

Annals of Faculty Engineering Hunedoara  
International Journal of Engineering  
Volume 16, Issue 1, Issue 2, Issue 3, Issue 4, 2018

<http://annals.fih.upt.ro/>

- The Journal is a multi-disciplinary journal which covers all aspects of scientific, engineering and technical disciplines including applications of scientific inventions for engineering, technological and industrial purposes, advances in engineering, technology and science.
- The Journal is accredited and ranked in the B+ category by The National University Research Council's Classification of Romanian Journals, CNCIS, and is indexed by Index Copernicus, Google Scholar, EBSCO Publishing, DOAJ, SCIRUS, EVISA, ProQuest, DRJI, CAS, BASE etc.



Academic Journal of Manufacturing Engineering  
Volume 16, Issue 1, Issue 2, Issue 3, Issue 4, 2018

[www.auif.utcluj.ro/en/](http://www.auif.utcluj.ro/en/)

- The Academic Journal of Manufacturing Engineering intends to provide the specialists in the manufacturing engineering field a possibility for sharing and exchanging results and information by publishing the results of their work.
- Academic Journal of Manufacturing Engineering is recognized as a B+ journal by the Romanian National Council of Scientific Research and indexed by Index Copernicus international database.





Journal of Architecture, Urbanism and Heritage  
Volume 1, Volume 2 , 2018

[www.jauh.ro/](http://www.jauh.ro/)

- The JOURNAL OF ARCHITECTURE, URBANISM AND HERITAGE, JAUH, is a peer-review academic journal which publishes original research papers and advances theory, research and practice in the fields of architecture and urban planning.
- The interdisciplinary scholarly publication is aimed at advancing conceptual, scientific, and applied understandings of Architecture, Interior design, Urbanism, Built environment and Preservation and heritage studies.
- Its articles include recent research findings, empirical research papers, theoretical and integrative review articles, book reviews and innovative new practices, creating a link between theory and practice, researchers and practicing professionals.



# ISI PAPERS



## EVOLUTION OF ISI PAPERS UNDER AFFILIATIONS OF UPT 2014 - 2018

Scientific writing and publication marks the endpoint of research that has been performed, completed, peer reviewed and accepted, and complements teaching and training.

In this chapter we present the publications/papers written by our professors, PhD students, researchers etc. These publications can be: papers published in ISI Journals or papers presented at Conference and indexed in ISI Proceedings.

The number of papers presented in the below figures is greater than the number of papers presented in previous Research Reports. This number varies from year to year because annually it increases the number of publications indexed in the ISI Clarivate Analytics database.

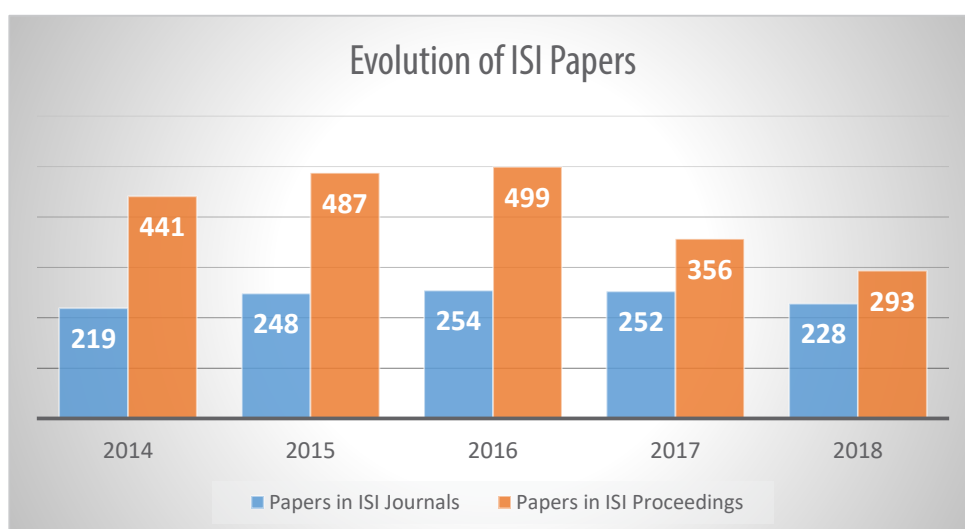
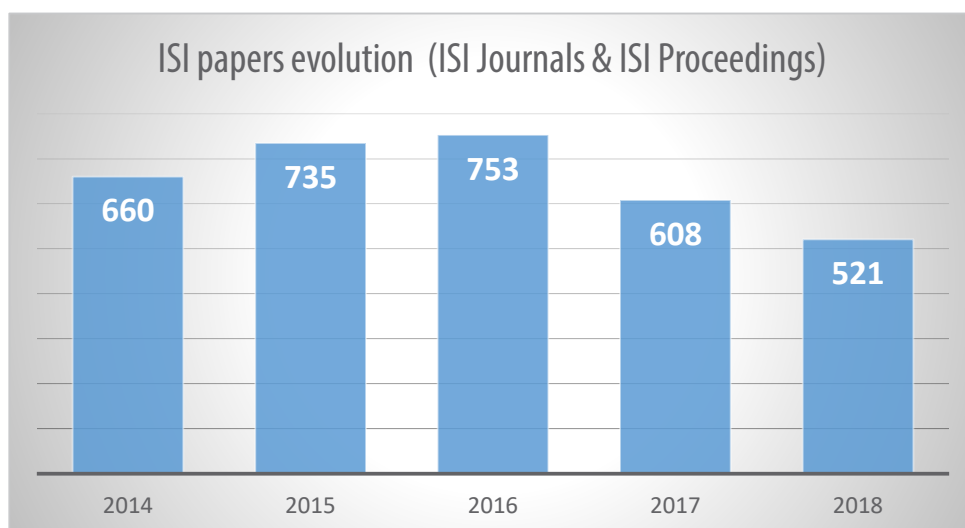

\* The data was obtained from Web of Science - Clarivate Analytics in 15 July 2019



*ISI Papers in highlight*





## Web of Science - Clarivate Analytics Highly Cited Papers

Selected from the most recent 10 years of data, Highly Cited Papers reflect the top 1% of papers by field and publication year. Highly Cited Papers help identify breakthrough research within a research field and are used within Web of Science to identify and refine the most influential research papers.

Precup, R.E., Hellendoorn, H. A survey on industrial applications of fuzzy control, *COMPUTERS IN INDUSTRY*, Volume: 62, Issue: 3, Pages: 213-226, ISSN: 0166-3615, eISSN: 1872-6194, 2011;  
Times Cited in Web of Science Core Collection: 244



Boldea, I., Tutelea, L.N., Parsa, L., Dorrell, D. Automotive Electric Propulsion Systems With Reduced or No Permanent Magnets: An Overview, *IEEE TRANSACTIONS ON INDUSTRIAL ELECTRONICS*, Volume: 61, Issue: 10, Pages: 5696-5711, ISSN: 0278-0046, eISSN: 1557-9948, 2014;  
Times Cited in Web of Science Core Collection: 221



Marinca, V., Herisanu, N. Application of Optimal Homotopy Asymptotic Method for solving nonlinear equations arising in heat transfer, *INTERNATIONAL COMMUNICATIONS IN HEAT AND MASS TRANSFER*, Volume: 35, Issue: 6, Pages: 710-715, ISSN: 0735-1933, 2008;  
Times Cited in Web of Science Core Collection: 198



Marinca, V., Herisanu, N., Bota, C., Marinca, B. An optimal homotopy asymptotic method applied to the steady flow of a fourth-grade fluid past a porous plate, *APPLIED MATHEMATICS LETTERS*, Volume: 22, Issue: 2, Pages: 245-251, ISSN: 0893-9659, 2009;  
Times Cited in Web of Science Core Collection: 160



Sarbu, I., Sebarchievici, C. General review of ground-source heat pump systems for heating and cooling of buildings, *ENERGY AND BUILDINGS*, Volume: 70, Pages: 441-454, ISSN: 0378-7788, eISSN: 1872-6178, 2014;  
Times Cited in Web of Science Core Collection: 148



Cadariu, L., Radu, V. Fixed point methods for the generalized stability of functional equations in a single variable, *FIXED POINT THEORY AND APPLICATIONS*, Article Number: 749392, ISSN: 1687-1820, 2008;  
Times Cited in Web of Science Core Collection: 128



Highly Cited Papers received enough citations as of January/December 2018 to place them in the top 1% of their academic fields based on a highly cited threshold for the field and publication year.

\*The data was obtained from Web of Science - Clarivate Analytics in 19 March 2019

## Web of Science - Clarivate Analytics Highly Cited Paper

Selected from the most recent 10 years of data, Highly Cited Papers reflect the top 1% of papers by field and publication year. Highly Cited Papers help identify breakthrough research within a research field and are used within Web of Science to identify and refine the most influential research papers.

Gheju, M., Balcu, I. Removal of chromium from Cr(VI) polluted wastewaters by reduction with scrap iron and subsequent precipitation of resulted cations, JOURNAL OF HAZARDOUS MATERIALS, Volume: 196, Pages: 131-138, PubMed ID: 21955659, ISSN: 0304-3894, 2011;  
Times Cited in Web of Science Core Collection: 121



Gheju, M., Balcu, I., Mosoarca, G. Removal of Cr(VI) from aqueous solutions by adsorption on MnO<sub>2</sub>, JOURNAL OF HAZARDOUS MATERIALS, Volume: 310, Pages: 270-277, PubMed ID: 26947189, ISSN: 0304-3894, eISSN: 1873-3336, 2016;  
Times Cited in Web of Science Core Collection: 47



Precup, R.E., David, R.C., Petriu, E.M. Grey Wolf Optimizer Algorithm-Based Tuning of Fuzzy Control Systems With Reduced Parametric Sensitivity, IEEE TRANSACTIONS ON INDUSTRIAL ELECTRONICS, Volume: 64, Issue: 1, Pages: 527-534, ISSN: 0278-0046, eISSN: 1557-9948, 2017;  
Times Cited in Web of Science Core Collection: 45



Precup, R.E., Radac, M.B., Roman, R.C., Petriu, E.M. Model-free sliding mode control of nonlinear systems: Algorithms and experiments, INFORMATION SCIENCES, Volume: 381, Pages: 176-192, ISSN: 0020-0255, eISSN: 1872-6291, 2017;  
Times Cited in Web of Science Core Collection: 35



Duma, V.F., Schitea, A. LASER SCANNERS WITH ROTATIONAL RISLEY PRISMS: EXACT SCAN PATTERNS, PROCEEDINGS OF THE ROMANIAN ACADEMY SERIES A-MATHEMATICS PHYSICS TECHNICAL SCIENCES INFORMATION SCIENCE, Volume: 19, Issue: 1, Pages: 53-60, ISSN: 1454-9069, 2018;  
Times Cited in Web of Science Core Collection: 6



Highly Cited Papers received enough citations as of January/December 2018 to place them in the top 1% of their academic fields based on a highly cited threshold for the field and publication year.

\*The data was obtained from Web of Science - Clarivate Analytics in 19 March 2019

## Web of Science - Clarivate Analytics Highly Cited Paper

As of January/December 2018, this highly cited paper received enough citations to place it in the top 1% of the academic field of **Computer Science** based on a highly cited threshold for the field and publication year.



Precup, R.E., Hellendoorn, H. A survey on industrial applications of fuzzy control, *COMPUTERS IN INDUSTRY*, Volume: 62, Issue: 3, Pages: 213-226, ISSN: 0166-3615, eISSN: 1872-6194, 2011;  
Times Cited in Web of Science Core Collection: 244

**Abstract:** Fuzzy control has long been applied to industry with several important theoretical results and successful results. Originally introduced as model-free control design approach, model-based fuzzy control has gained widespread significance in the past decade.

This paper presents a survey on recent developments of analysis and design of fuzzy control systems focused on industrial applications reported after 2000.

## Web of Science - Clarivate Analytics Highly Cited Paper

As of March/December 2018, this highly cited paper received enough citations to place it in the top 1% of the academic field of **Engineering** based on a highly cited threshold for the field and publication year.

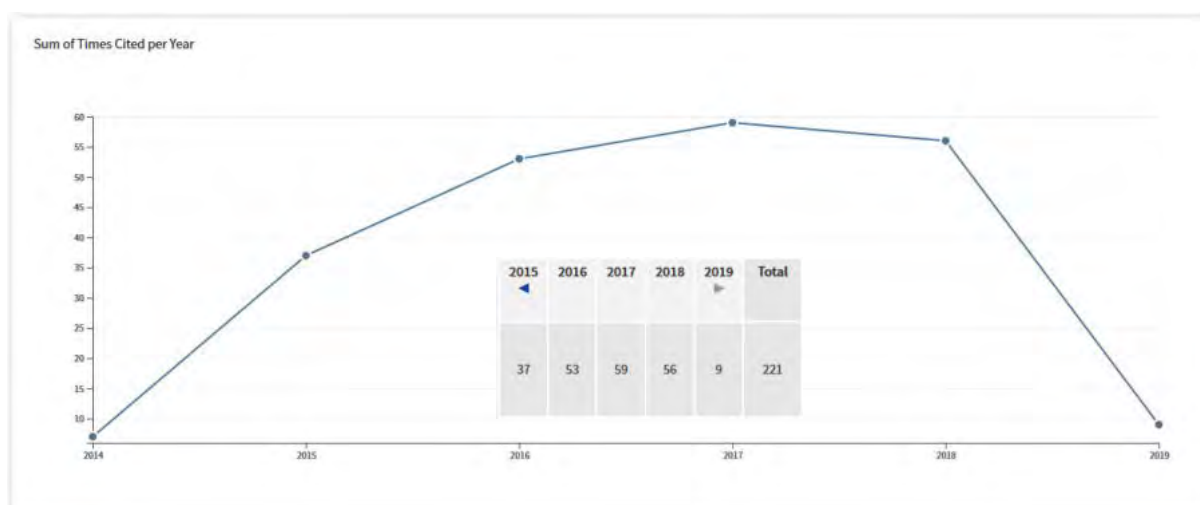

Boldea, I., Tutelea, L.N., Parsa, L., Dorrell, D. Automotive Electric Propulsion Systems With Reduced or No Permanent Magnets: An Overview, IEEE TRANSACTIONS ON INDUSTRIAL ELECTRONICS, Volume: 61, Issue: 10, Pages: 5696-5711, ISSN: 0278-0046, eISSN: 1557-9948, 2014; Times Cited in Web of Science Core Collection: 221

**Abstract:** Hybrid and electric vehicle technology has seen rapid development in recent years. The motor and the generator are at the heart of the vehicle drive and energy system and often utilize expensive rare-earth permanent magnet (PM) material. This paper reviews and addresses the research work that has been carried out to reduce the amount of rare-earth material that is used while maintaining the high efficiency and performance that rare-earth PM machines offer. These new machines can use either less rare-earth PM material,

weaker ferrite magnets, or no magnets; and they need to meet the high performance that the more usual interior PM synchronous motor with sintered neodymium-iron-boron magnets provides. These machines can take the form of PM-assisted synchronous reluctance machines, induction machines, switched reluctance machines, wound rotor synchronous machines (claw pole or biaxially excited), double-saliency machines with ac or dc stator current control, or brushless dc multiple-phase reluctance machines.

## Web of Science - Clarivate Analytics Highly Cited Paper

As of January/December 2018, this highly cited paper received enough citations to place it in the top 1% of the academic field of **Engineering** based on a highly cited threshold for the field and publication year.

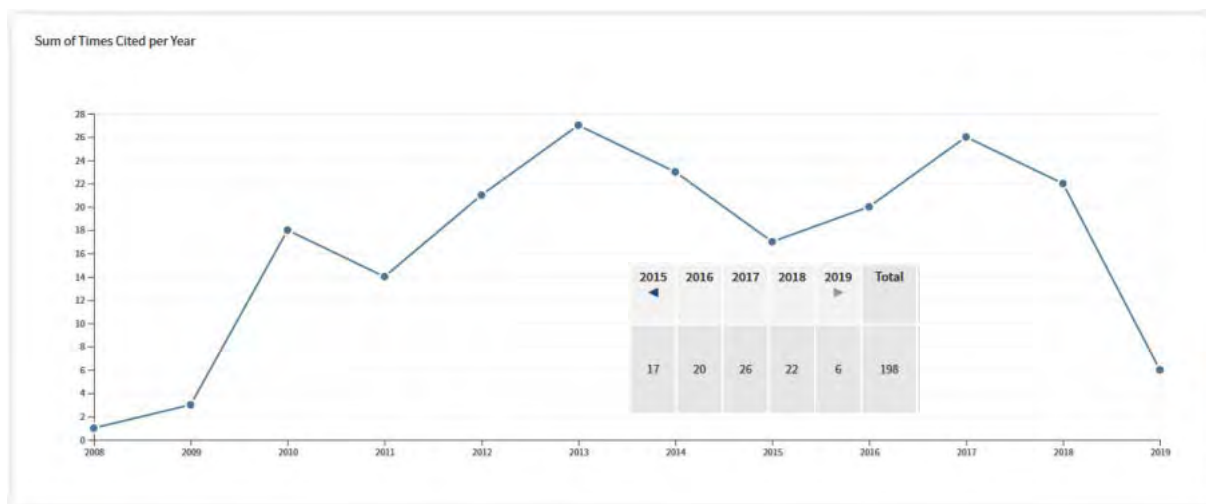

Marinca, V., Herisanu, N. Application of Optimal Homotopy Asymptotic Method for solving nonlinear equations arising in heat transfer, INTERNATIONAL COMMUNICATIONS IN HEAT AND MASS TRANSFER, Volume: 35, Issue: 6, Pages: 710-715, ISSN: 0735-1933, 2008;  
Times Cited in Web of Science Core Collection: 198

**Abstract:** We consider one of the newest analytical methods, the Optimal Homotopy Asymptotic Method (OHAM), to solve nonlinear equations arising in heat transfer. Two specific applications are considered: cooling of a lumped system with variable specific heat and the temperature distribution equation in a thick rectangular fin radiation to free space. Results obtained by OHAM, which does not

need small parameters are compared with numerical results and a very good agreement was found. This method provides us with a convenient way to control the convergence of approximation series and adjust convergence regions when necessary. The results reveal that the proposed method is explicit, effective and easy to use.

## Web of Science - Clarivate Analytics Highly Cited Paper

As of January/December 2018, this highly cited paper received enough citations to place it in the top 1% of the academic field of **Mathematics** based on a highly cited threshold for the field and publication year.

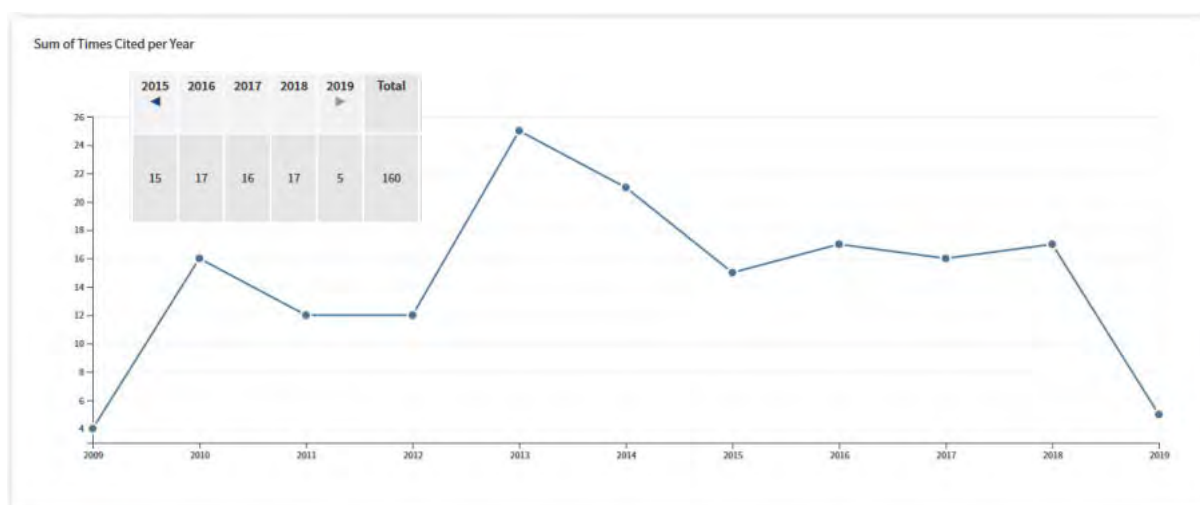

Marinca, V., Herisanu, N., Bota, C., Marinca, B. An optimal homotopy asymptotic method applied to the steady flow of a fourth-grade fluid past a porous plate, *APPLIED MATHEMATICS LETTERS*, Volume: 22, Issue: 2, Pages: 245-251, ISSN: 0893-9659, 2009;  
Times Cited in Web of Science Core Collection: 160

**Abstract:** A new analytic approximate technique for addressing nonlinear problems, namely the Optimal Homotopy Asymptotic Method (OHAM), is proposed and used in an application to the steady flow of a fourth-grade fluid. This approach does not depend upon any small/large parameters. This method provides us with a convenient

way to control the convergence of approximation series and adjust convergence regions when necessary. The series solution is developed and the recurrence relations are given explicitly. The results reveal that the proposed method is effective and easy to use.

## Web of Science - Clarivate Analytics Highly Cited Paper

As of January/December 2018, this highly cited paper received enough citations to place it in the top 1% of the academic field of **Engineering** based on a highly cited threshold for the field and publication year.

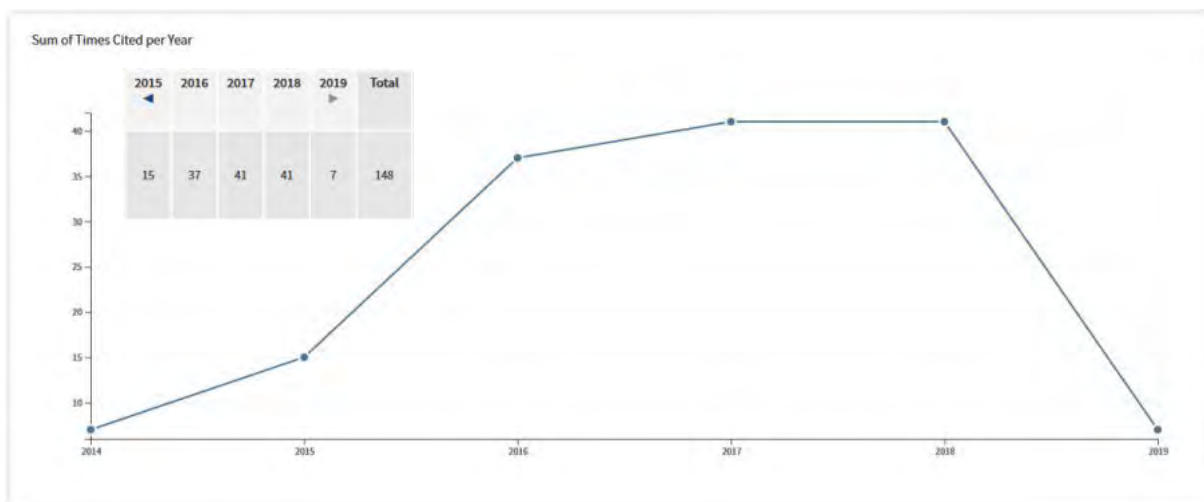

Sarbu, I., Sebarchievici, C. General review of ground-source heat pump systems for heating and cooling of buildings, *ENERGY AND BUILDINGS*, Volume: 70, Pages: 441-454, ISSN: 0378-7788, eISSN: 1872-6178, 2014;  
Times Cited in Web of Science Core Collection: 148

**Abstract:** A large number of ground-source heat pumps (GSHP) systems have been used in residential and commercial buildings throughout the world due to the attractive advantages of high energy and environmental performances. The GSHPs are proven renewable energy technology for space heating and cooling. This paper provides a detailed literature review of the GSHP systems, and their recent advances. The operation principle and energy efficiency of a heat pump are defined first. Then, a general introduction on the GSHPs and its development, and a detailed description of the surface water (SWHP), ground-water (GWHP), and ground-couplet (GCHP) heat pumps are performed. The most typical simulation and ground thermal response

test models for the vertical ground heat exchangers currently available are summarized including the heat transfer processes outside and inside the boreholes. Also, some information about a new GWHP using a heat exchanger with special construction, and the possibility to obtain the better energy efficiency with combined heating and cooling by GCHP are presented. The various hybrid GCHP systems for cooling or heating-dominated buildings are well described. Finally, the energy, economic and environmental performance of a closed-loop GCHP system is also briefly reviewed. It is found that the GSHP technology can be used both in cold and hot weather areas and the energy saving potential is significant.

## Web of Science - Clarivate Analytics Highly Cited Paper

As of January/December 2018, this highly cited paper received enough citations to place it in the top 1% of the academic field of **Mathematics** based on a highly cited threshold for the field and publication year.

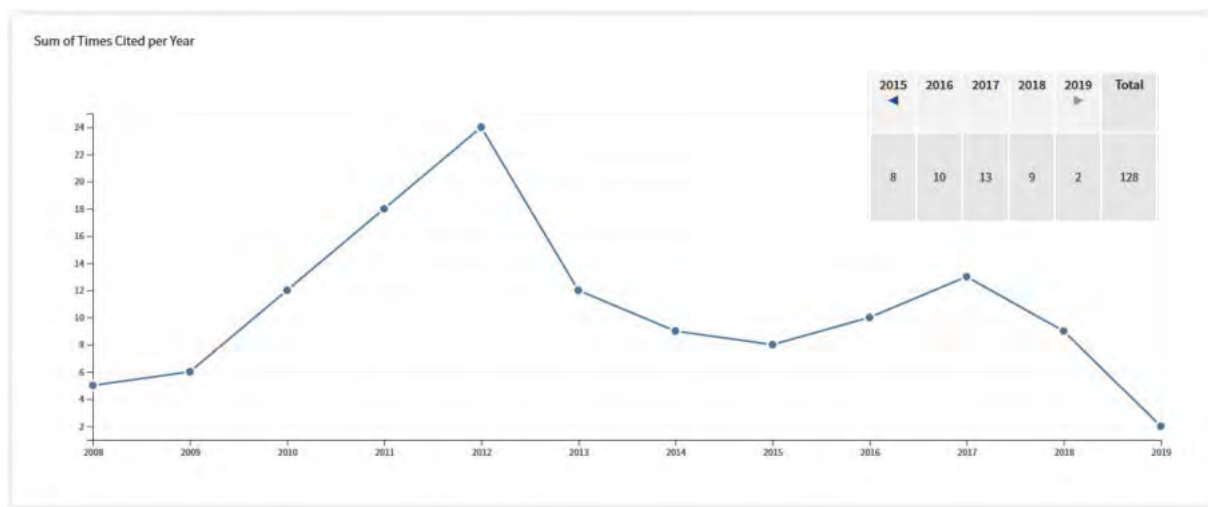

Cadariu, L., Radu, V. Fixed point methods for the generalized stability of functional equations in a single variable, *FIXED POINT THEORY AND APPLICATIONS*, Article Number: 749392, ISSN: 1687-1820, 2008;  
Times Cited in Web of Science Core Collection: 128

Abstract: We discuss on the generalized Ulam-Hyers stability for functional equations in a single variable, including the nonlinear functional equations, the linear functional equations, and a generalization of functional equation for the square root spiral. The

stability results have been obtained by a fixed point method. This method introduces a metrical context and shows that the stability is related to some fixed point of a suitable operator.



## Web of Science - Clarivate Analytics Highly Cited Paper

As of January/December 2018, this highly cited paper received enough citations to place it in the top 1% of the academic field of **Engineering** based on a highly cited threshold for the field and publication year.

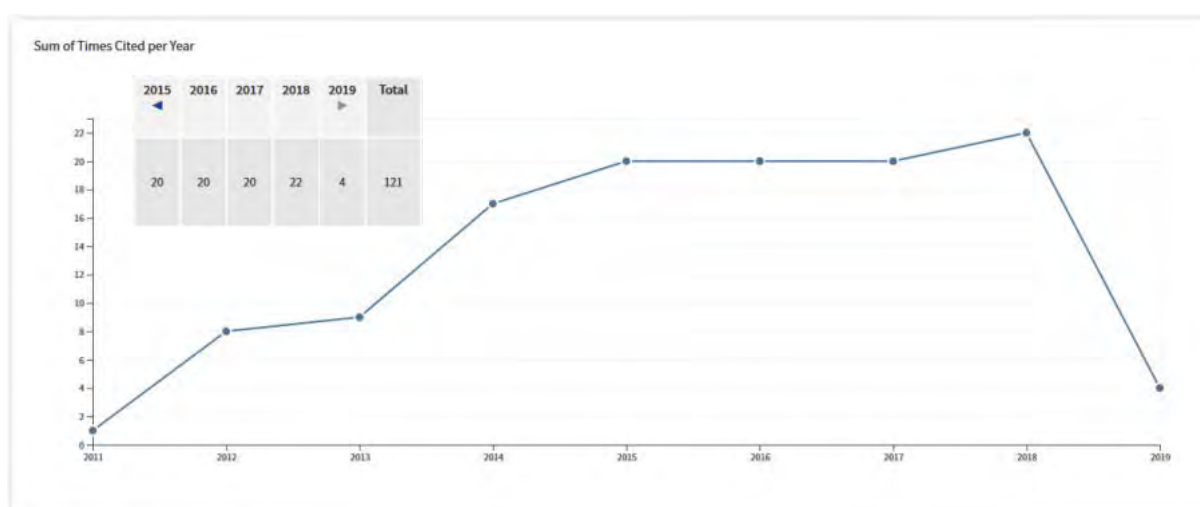

Gheju, M., Balcu, I. Removal of chromium from Cr(VI) polluted wastewaters by reduction with scrap iron and subsequent precipitation of resulted cations, *JOURNAL OF HAZARDOUS MATERIALS*, Volume: 196, Pages: 131-138, PubMed ID: 21955659, ISSN: 0304-3894, 2011;  
Times Cited in Web of Science Core Collection: 121

**Abstract:** This work presents investigations on the total removal of chromium from Cr(VI) aqueous solutions by reduction with scrap iron and subsequent precipitation of the resulted cations with NaOH. The process was detrimentally affected by a compactly passivation film occurred at scrap iron surface, mainly composed of Cr(III) and Fe(III). Maximum removal efficiency of the Cr(total) and Fe(total) achieved in the clarifier under circumneutral and alkaline (pH 9.1) conditions was 98.5% and 100%, respectively. The optimum precipitation pH range which resulted from this study is 7.6-8.0. Fe(total) and Cr(total) were

almost entirely removed in the clarifier as Fe(III) and Cr(III) species: however, after Cr(VI) breakthrough in column effluent, chromium was partially removed in the clarifier also as Cr(VI), by coprecipitation with cationic species. As long the column effluent was free of Cr(VI), the average Cr(total) removal efficiency of the packed column and clarifier was 10.8% and 78.8%, respectively. Our results clearly indicated that Cr(VI) contaminated wastewater can be successfully treated by combining reduction with scrap iron and chemical precipitation with NaOH.

## Web of Science - Clarivate Analytics Highly Cited Paper

As of March/June and November/December 2018, this highly cited paper received enough citations to place it in the top 1% of the academic field of **Engineering** based on a highly cited threshold for the field and publication year.

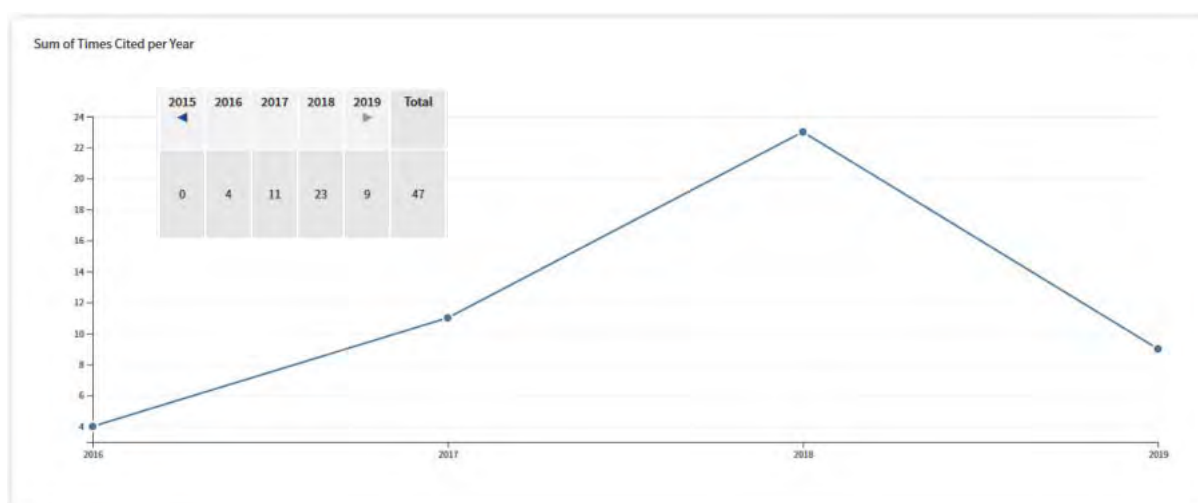

Gheju, M., Balcu, I., Mosoarca, G. Removal of Cr(VI) from aqueous solutions by adsorption on MnO<sub>2</sub>, JOURNAL OF HAZARDOUS MATERIALS, Volume: 310, Pages: 270-277, PubMed ID: 26947189, ISSN: 0304-3894, eISSN: 1873-3336, 2016;  
Times Cited in Web of Science Core Collection: 47

**Abstract:** Adsorption of Cr(VI) on MnO<sub>2</sub> was investigated with respect to effect of pH, temperature, ionic strength, initial Cr(VI) concentration, co-presence of different anions (HCO<sub>3</sub><sup>-</sup>, SO<sub>4</sub><sup>2-</sup>, H<sub>2</sub>PO<sub>4</sub><sup>-</sup>, NO<sub>3</sub><sup>-</sup> and Cl<sup>-</sup>) and of low molecular weight natural organic materials (LMWNOM) (acetate, oxalate and citrate). The process was rapid during the first 3-5 min, reaching equilibrium after one hour. Adsorption decreased with increasing pH, temperature and Cr(VI) initial concentration, and increased with increasing ionic strength. Co-presence of phosphate, sulfate, bicarbonate, citrate and oxalate hindered Cr(VI) adsorption, whereas nitrate, chloride and acetate did not exert any notable influence. The overall order of Cr(VI) adsorption suppression due to

co-presence of anions and LMWNOM was H<sub>2</sub>PO<sub>4</sub><sup>-</sup> > HCO<sub>3</sub><sup>-</sup> > SO<sub>4</sub><sup>2-</sup>, and oxalate > citrate, respectively. Highest experimental equilibrium sorption capacity (0.83 mg g<sup>-1</sup>) was obtained at 20 degrees C and pH 5.9, while lowest (0.18 mg g<sup>-1</sup>) was noticed in the co-presence of H<sub>2</sub>PO<sub>4</sub><sup>-</sup>, at 20 degrees C and pH 6.9. Adsorption kinetics was successfully fitted by pseudo-second-order model. Mechanisms for both specific and non-specific adsorption are likely to be involved, while rate-controlling step involved both intra-particle and film diffusion processes. Cr(VI) was strongly bound to MnO<sub>2</sub>, which makes risks of its subsequent liberation into the environment to be low.

## Web of Science - Clarivate Analytics Highly Cited Paper

As of November/December 2018, this highly cited paper received enough citations to place it in the top 1% of the academic field of **Engineering** based on a highly cited threshold for the field and publication year.

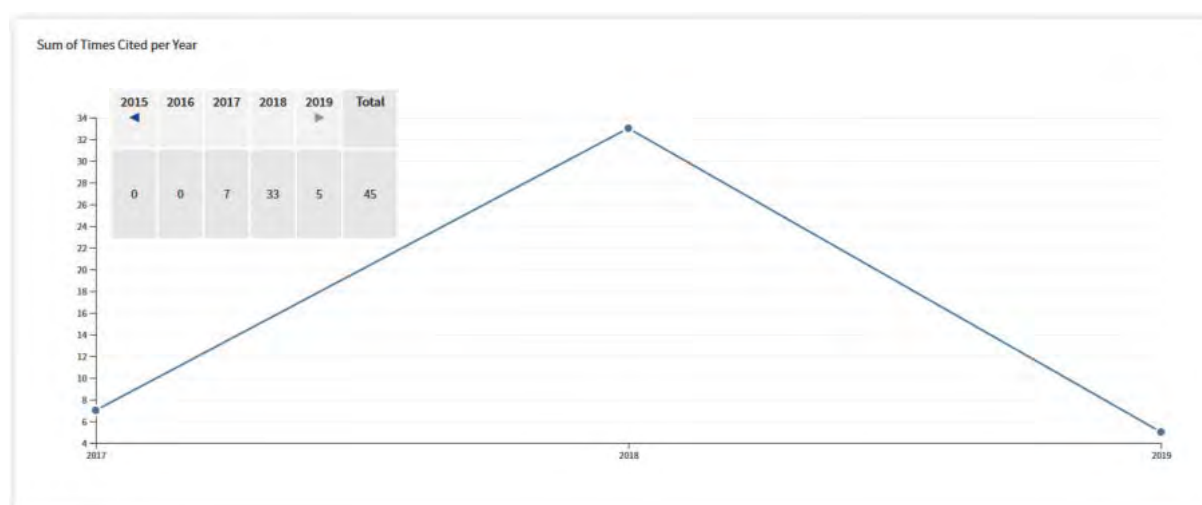

Precup, R.E., David, R.C., Petriu, E.M. Grey Wolf Optimizer Algorithm-Based Tuning of Fuzzy Control Systems With Reduced Parametric Sensitivity, *IEEE TRANSACTIONS ON INDUSTRIAL ELECTRONICS*, Volume: 64, Issue: 1, Pages: 527-534, ISSN: 0278-0046, eISSN: 1557-9948, 2017;  
Times Cited in Web of Science Core Collection: 45

**Abstract:** This paper proposes an innovative tuning approach for fuzzy control systems (CSs) with a reduced parametric sensitivity using the Grey Wolf Optimizer (GWO) algorithm. The CSs consist of servo system processes controlled by Takagi-Sugeno-Kang proportional-integral fuzzy controllers (TSK PI-FCs). The process models have second-order dynamics with an integral component, variable parameters, a saturation, and dead-zone static nonlinearity. The sensitivity analysis employs output sensitivity functions of the sensitivity models defined

with respect to the parametric variations of the processes. The GWO algorithm is used in solving the optimization problems, where the objective functions include the output sensitivity functions. GWO's motivation is based on its low-computational cost. The tuning approach is validated in an experimental case study of a position control for a laboratory nonlinear servo system, and TSK PI-FCs with a reduced process small time constant sensitivity are offered.

## Web of Science - Clarivate Analytics Highly Cited Paper

As of March/June and September/October 2018, this highly cited paper received enough citations to place it in the top 1% of the academic field of **Computer Science** based on a highly cited threshold for the field and publication year.

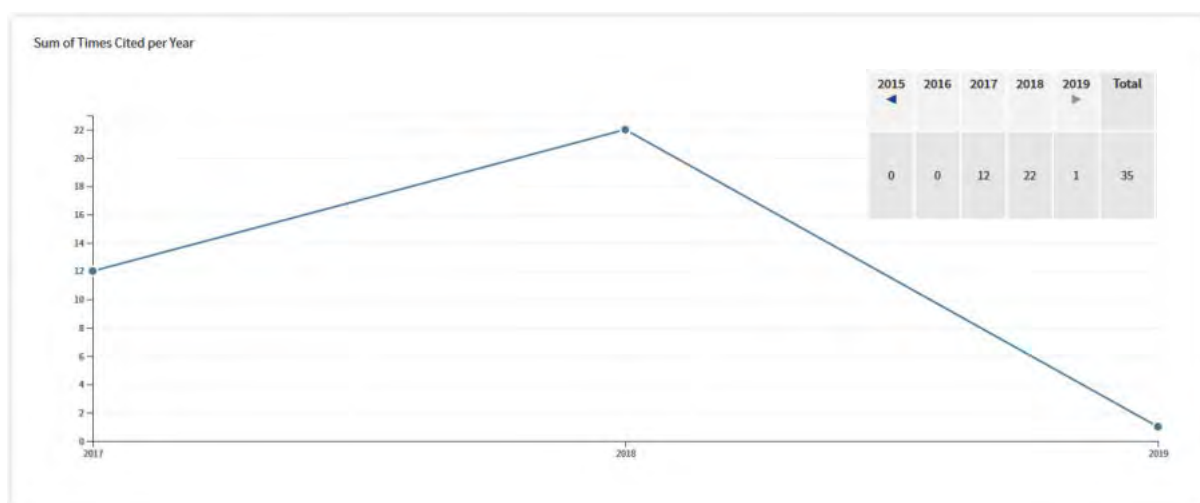

Precup, R.E., Radac, M.B., Roman, R.C., Petriu, E.M. Model-free sliding mode control of nonlinear systems: Algorithms and experiments, *INFORMATION SCIENCES*, Volume: 381, Pages: 176-192, ISSN: 0020-0255, eISSN: 1872-6291, 2017; Times Cited in Web of Science Core Collection: 35

**Abstract:** This paper proposes two model-free sliding mode control system (MFSMCS) structures. The new structures are compared with a model-free intelligent proportional-integral (iPI) control system structure. Two simple design approaches for the MFSMCS structures are suggested. The control system structures and the design approaches are validated by a set of real-time experimental results on a nonlinear laboratory twin rotor aerodynamic system

(TRAS). The MFSMCS structures are considered in the framework of a Multi Input-Multi Output TRAS control system, where the azimuth and pitch positions are controlled using separate Single Input-Single Output control system structures for each control channel (azimuth and pitch). The experimental validation is carried out by two scenarios that illustrate and allow the assessment of the MFSMCS structures performance and the comparison versus a model-free iPI control system structure as well.

## Web of Science - Clarivate Analytics Highly Cited Paper

As of March/December 2018, this highly cited paper received enough citations to place it in the top 1% of the academic field of **Mathematics** based on a highly cited threshold for the field and publication year.

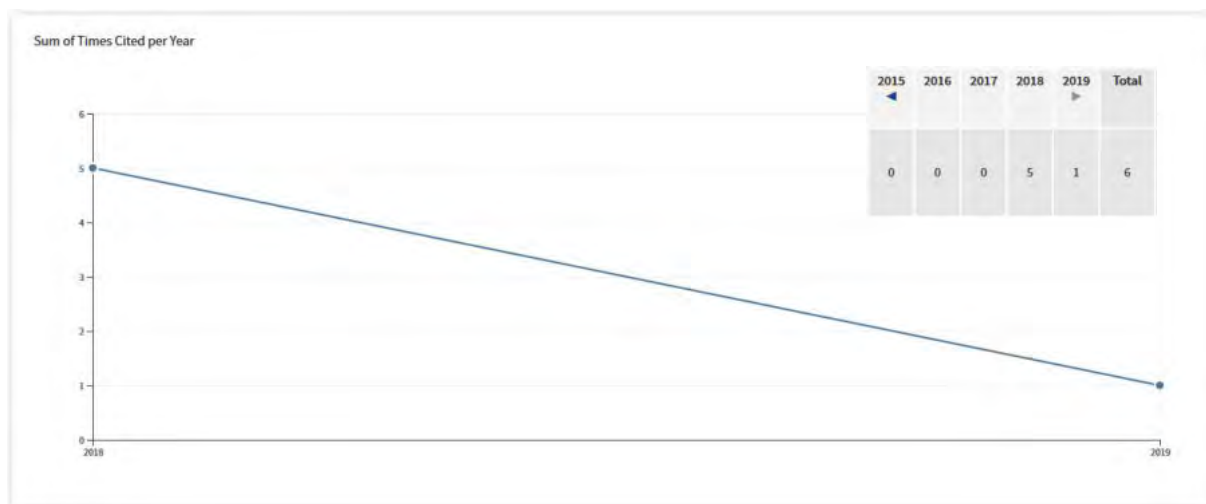

Duma, V.F., Schitea, A. LASER SCANNERS WITH ROTATIONAL RISLEY PRISMS: EXACT SCAN PATTERNS, PROCEEDINGS OF THE ROMANIAN ACADEMY SERIES A-MATHEMATICS PHYSICS TECHNICAL SCIENCES INFORMATION SCIENCE, Volume: 19, Issue: 1, Pages: 53-60, ISSN: 1454-9069, 2018; Times Cited in Web of Science Core Collection: 6

**Abstract:** We approach the exact scan patterns produced by scanners with rotational Risley prisms. Previous methods have considered such studies mostly approximately, in the paraxial domain or using the third-order theory. Exact, but complicated analytical solutions have also been developed. In contrast, we propose a novel, easy-to-use, graphical method, in order to complete the exact modeling of the scanning process: with a mechanical design program, CATIA V5R20 (Dassault Systemes, Paris, France). By ray-tracing using the prisms

equations, the scan patterns are determined and studied with regard to the characteristic parameters of the device: prism angles and their rotational speeds, as well as the scanner geometry. Marshall's characteristic parameters are utilized: the ratios of the prism angles and of the rotational speeds. An experimental validation of the modeling procedure is completed. The exact modeling method proposed allows for choosing the most appropriate parameters of the device in order to obtain a certain scan pattern for a specific application.



No.	Article	2017 Impact Factor / Quartile in Category
1.	Abdullah, A.D., Castro-Gama, M.E., Popescu, I., van der Zaag, P., Karim, U., Al Suhail, Q. Optimization of water allocation in the Shatt al-Arab River under different salinity regimes and tide impact, HYDROLOGICAL SCIENCES JOURNAL-JOURNAL DES SCIENCES HYDROLOGIQUES, Volume: 63, Issue: 4, Pages: 646-656, ISSN: 0262-6667, eISSN: 2150-3435, 2018;	2.061 / Q2
2.	Aliha, M.R.M., Linul, E., Bahmani, A., Marsavina, L. Experimental and theoretical fracture toughness investigation of PUR foams under mixed mode I plus III loading, POLYMER TESTING, Volume: 67, Pages: 75-83, ISSN: 0142-9418, eISSN: 1873-2348, 2018;	2.247 / Q2
3.	Ancuti, C.O., Ancuti, C., De Vleeschouwer, C., Bekaert, P. Color Balance and Fusion for Underwater Image Enhancement, IEEE TRANSACTIONS ON IMAGE PROCESSING, Volume: 27, Issue: 1, Pages: 379-393, PubMed ID: 28981416, ISSN: 1057-7149, eISSN: 1941-0042, 2018;	5.072 / Q1
4.	Ancuti, C., Ancuti, C.O., de Vleeschouwer, C., Sbert, M. Decolorization by Fusion, IEEE ACCESS, Volume: 6, Pages: 64071-64084, ISSN: 2169-3536, 2018;	3.557 / Q1
5.	Baloi, M.A., Crucean, C., Popescu, D. Scalar pair production in a magnetic field in de Sitter universe, EUROPEAN PHYSICAL JOURNAL C, Volume: 78, Issue: 5, Article Number: 398, ISSN: 1434-6044, eISSN: 1434-6052, 2018;	5.172 / Q1
6.	Belega, D., Petri, D. Effect of windowing and noise on the amplitude and phase estimators returned by the Taylor-based Weighted Least Squares, DIGITAL SIGNAL PROCESSING, Volume: 83, Pages: 202-213, ISSN: 1051-2004, eISSN: 1095-4333, 2018;	2.241 / Q2
7.	Belega, D., Petri, D., Dallet, D. Accurate amplitude and phase estimation of noisy sine-waves via two-point interpolated DTFT algorithms, MEASUREMENT, Volume: 127, Pages: 89-97, ISSN: 0263-2241, eISSN: 1873-412X, 2018;	2.218 / Q2
8.	Belega, D., Petri, D., Dallet, D. Amplitude and Phase Estimation of Real-Valued Sine Wave via Frequency-Domain Linear Least-Squares Algorithms, IEEE TRANSACTIONS ON INSTRUMENTATION AND MEASUREMENT, Volume: 67, Issue: 5, Special Issue: SI, Pages: 1065-1077, ISSN: 0018-9456, eISSN: 1557-9662, 2018;	2.794 / Q1
9.	Belega, D., Petri, D., Dallet, D. INFLUENCE OF THE SPECTRAL IMAGE COMPONENT ON THE AMPLITUDE AND PHASE ESTIMATORS PROVIDED BY THE INTERPOLATED DFT METHOD, PROCEEDINGS OF THE ROMANIAN ACADEMY SERIES A-MATHEMATICS PHYSICS TECHNICAL SCIENCES INFORMATION SCIENCE, Volume: 19, Issue: 2, Pages: 377-384, ISSN: 1454-9069, 2018;	1.752 / Q2
10.	Belega, D., Petri, D., Dallet, D. Accurate frequency estimation of a noisy sine-wave by means of an interpolated discrete-time Fourier transform algorithm, MEASUREMENT, Volume: 116, Pages: 685-691, ISSN: 0263-2241, eISSN: 1873-412X, 2018;	2.218 / Q2
11.	Berei, E., Stefanescu, O., Muntean, C., Vlase, T., Taranu, B.O., Dabici, A., Stefanescu, M. A novel route for the preparation of CoCr2O4/SiO2 nanocomposite starting from Co(II)-Cr(III) carboxylate complex combinations, JOURNAL OF MATERIALS SCIENCE, Volume: 53, Issue: 6, Pages: 4159-4172, ISSN: 0022-2461, eISSN: 1573-4803, 2018;	2.993 / Q2
12.	Berei, E., Muntean, C., Stefanescu, O., Niculescu, M., Stefanescu, M. Preparation of CuCr2O4 nanopowders using two different chromium sources, JOURNAL OF THERMAL ANALYSIS AND CALORIMETRY, Volume: 131, Issue: 1, Pages: 137-144, ISSN: 1388-6150, eISSN: 1588-2926, 2018;	2.209 / Q2
13.	Binzar, T., Lazureanu, C. Wold-Type Decompositions for a Commutative Pair of Noncommutative Semigroups of Isometries, BULLETIN OF THE MALAYSIAN MATHEMATICAL SCIENCES SOCIETY, Volume: 41, Issue: 2, Pages: 1139-1150, ISSN: 0126-6705, eISSN: 2180-4206, 2018;	0.84 / Q2

No.	Article	2017 Impact Factor / Quartile in Category
14.	Boldea, I., Tutelea, L.N., Xu, W., Pucci, M. Linear Electric Machines, Drives, and MAGLEVs: An Overview, IEEE TRANSACTIONS ON INDUSTRIAL ELECTRONICS, Volume: 65, Issue: 9, Pages: 7504-7515, ISSN: 0278-0046, eISSN: 1557-9948, 2018;	7.05 / Q1
15.	Buse, C., Nguyen, L.T., O'Regan, D. GLOBAL AND LOCAL VERSIONS FOR A PHONG VU THEOREM FOR PERIODIC EVOLUTION FAMILIES IN HILBERT SPACES, ELECTRONIC JOURNAL OF DIFFERENTIAL EQUATIONS, Article Number: 188, ISSN: 1072-6691, 2018;	0.944 / Q2
16.	Calinoiu, D., Stefu, N., Boata, R., Blaga, R., Pop, N., Paulescu, E., Sabadus, A., Paulescu, M. Parametric modeling: A simple and versatile route to solar irradiance, ENERGY CONVERSION AND MANAGEMENT, Volume: 164, Pages: 175-187, ISSN: 0196-8904, eISSN: 1879-2227, 2018;	6.377 / Q1
17.	Chesoan, A., Stratan, A., Dubina, D. Design implementation of re-centring dual eccentrically braced frames with removable links, SOIL DYNAMICS AND EARTHQUAKE ENGINEERING, Volume: 112, Pages: 174-184, ISSN: 0267-7261, eISSN: 1879-341X, 2018;	2.077 / Q2
18.	Circu, M., Bunge, A., Vasilescu, C., Porav, S., Nan, A. Non-catalytic, solvent-free synthesis of poly(tartronic-co-glycolic acid) as a versatile coating for different surfaces, POLYMER INTERNATIONAL, Volume: 67, Issue: 2, Pages: 212-219, ISSN: 0959-8103, eISSN: 1097-0126, 2018;	2.352 / Q2
19.	Cocheci, L., Lupa, L., Gheju, M., Golban, A., Lazau, R., Pode, R. Zn-Al-CO <sub>3</sub> layered double hydroxides prepared from a waste of hot-dip galvanizing process, CLEAN TECHNOLOGIES AND ENVIRONMENTAL POLICY, Volume: 20, Issue: 5, Pages: 1105-1112, ISSN: 1618-954X, eISSN: 1618-9558, 2018;	2.343 / Q2
20.	Craciunescu, C., Mitelea, I. Combined effects in quasisimilar NiTi joints manufactured by pulsed laser welding, MATERIALS SCIENCE AND ENGINEERING A-STRUCTURAL MATERIALS PROPERTIES MICROSTRUCTURE AND PROCESSING, Volume: 737, Pages: 364-372, ISSN: 0921-5093, eISSN: 1873-4936, 2018;	3.414 / Q1
21.	Crispini, A., Cretu, C., Aparaschivei, D., Andelesc, A.A., Sasca, V., Badea, V., Aiello, I., Szerb, E.I., Costisor, O. Influence of the counterion on the geometry of Cu(I) and Cu(II) complexes with 1,10-phenanthroline, INORGANICA CHIMICA ACTA, Volume: 470, Special Issue: SI, Pages: 342-351, ISSN: 0020-1693, eISSN: 1873-3255, 2018;	2.264 / Q2
22.	Curiac, D.I., Baniias, O., Volosencu, C., Curiac, C.D. Novel Bioinspired Approach Based on Chaotic Dynamics for Robot Patrolling Missions with Adversaries, ENTROPY, Volume: 20, Issue: 5, Article Number: UNSP 378, ISSN: 1099-4300, 2018;	2.305 / Q2
23.	de Miranda, S., Melchionda, D., Ungureanu, V., Dubina, D. A modified ECBL approach for cold-formed steel rack section members, THIN-WALLED STRUCTURES, Volume: 130, Pages: 47-56, ISSN: 0263-8231, eISSN: 1879-3223, 2018;	2.881 / Q1
24.	Declercq, D., Savin, V., Boncalo, O., Ghaffari, F. An Imprecise Stopping Criterion Based on In-Between Layers Partial Syndromes, IEEE COMMUNICATIONS LETTERS, Volume: 22, Issue: 1, Pages: 13-16, ISSN: 1089-7798, eISSN: 1558-2558, 2018;	2.723 / Q2
25.	Diudea, M.V., Pirvan-Moldovan, A., Pop, R., Medeleanu, M. Energy of Graphs and Remote Graphs in Hypercubes, Rhombellanes and Fullerenes, MATCH-COMMUNICATIONS IN MATHEMATICAL AND IN COMPUTER CHEMISTRY, Volume: 80, Issue: 3, Pages: 835-852, ISSN: 0340-6253, 2018;	2.58 / Q1
26.	Duma, V.F., Schitea, A. LASER SCANNERS WITH ROTATIONAL RISLEY PRISMS: EXACT SCAN PATTERNS, PROCEEDINGS OF THE ROMANIAN ACADEMY SERIES A-MATHEMATICS PHYSICS TECHNICAL SCIENCES INFORMATION SCIENCE, Volume: 19, Issue: 1, Pages: 53-60, ISSN: 1454-9069, 2018;	1.752 / Q2



No.	Article	2017 Impact Factor / Quartile in Category
27.	Dumitru, R., Manea, F., Pacurariu, C., Lupa, L., Pop, A., Cioabla, A., Surdu, A., Ianculescu, A. Synthesis, Characterization of Nanosized ZnCr2O4 and Its Photocatalytic Performance in the Degradation of Humic Acid from Drinking Water, CATALYSTS, Volume: 8, Issue: 5, Article Number: 210, ISSN: 2073-4344, 2018;	3.465 / Q2
28.	Gheju, M. Progress in Understanding the Mechanism of Cr-VI Removal in Fe-O-Based Filtration Systems, WATER, Volume: 10, Issue: 5, Article Number: 651, ISSN: 2073-4441, Published: 2018;	2.069 / Q2
29.	Gherhes, V., Obrad, C. Technical and Humanities Students' Perspectives on the Development and Sustainability of Artificial Intelligence (AI), SUSTAINABILITY, Volume: 10, Issue: 9, Article Number: 3066, ISSN: 2071-1050, 2018;	2.075 / Q2
30.	Gontean, A., Lica, S., Bularka, S., Szabo, R., Lascu, D. A Novel High Accuracy PV Cell Model Including Self Heating and Parameter Variation, ENERGIES, Volume: 11, Issue: 1, Article Number: 36, ISSN: 1996-1073, 2018;	2.676 / Q2
31.	Greuc, E., Aceleanu, M.I., Albulescu, C.T. The economic, social and environmental impact of shale gas exploitation in Romania: A cost-benefit analysis, RENEWABLE & SUSTAINABLE ENERGY REVIEWS, Volume: 93, Pages: 691-700, ISSN: 1364-0321, Published: 2018;	9.184 / Q1
32.	Grigorie, A.C., Muntean, C., Vlase, G., Stefanescu, M. Synthesis and characterization of ZnAl2O4 spinel from Zn(II) and Al(III) carboxylates, JOURNAL OF THERMAL ANALYSIS AND CALORIMETRY, Volume: 131, Issue: 1, Pages: 183-189, ISSN: 1388-6150, eISSN: 1588-2926, 2018;	2.209 / Q2
33.	Groza, B., Murvay, P.S. SECURITY SOLUTIONS FOR THE CONTROLLER AREA NETWORK Bringing Authentication to In-Vehicle Networks, IEEE VEHICULAR TECHNOLOGY MAGAZINE, Volume: 13, Issue: 1, Pages: 40-47, ISSN: 1556-6072, eISSN: 1556-6080, 2018;	6.038 / Q1
34.	Gurbina, M., Ciresan, A., Lascu, D., Lica, S., Pop-Calimanu, I.M. A New Exact Mathematical Approach for Studying Bifurcation in DCM Operated dc-dc Switching Converters, ENERGIES, Volume: 11, Issue: 3, Article Number: 663, ISSN: 1996-1073, 2018;	2.676 / Q2
35.	Hutiu, G., Duma, V.F., Demian, D., Bradu, A., Podoleanu, A.G. Assessment of Ductile, Brittle, and Fatigue Fractures of Metals Using Optical Coherence Tomography, METALS, Volume: 8, Issue: 2, Article Number: 117, ISSN: 2075-4701, 2018;	1.704 / Q2
36.	Ianos, R. Key-role of the recipe formulation in the solution combustion synthesis of monocalcium aluminate, CaAl2O4, CERAMICS INTERNATIONAL, Volume: 44, Issue: 17, Pages: 21908-21913, ISSN: 0272-8842, eISSN: 1873-3956, 2018;	3.057 / Q1
37.	Ianos, R., Moaca, E.A., Capraru, A., Lazau, R., Pacurariu, C. Maghemite, gamma-Fe2O3, nanoparticles preparation via carbon-templated solution combustion synthesis, CERAMICS INTERNATIONAL, Volume: 44, Issue: 12, Pages: 14090-14094, ISSN: 0272-8842, eISSN: 1873-3956, 2018;	3.057 / Q1
38.	Ianos, R., Lazau, R., Babuta, R., Muntean, E., Moaca, E.A., Pacurariu, C. Solution combustion synthesis: a straightforward route for the preparation of chromium-doped lanthanum aluminate, LaAl1-xCrxO3, pink red pigments, DYES AND PIGMENTS, Volume: 155, Pages: 218-224, ISSN: 0143-7208, eISSN: 1873-3743, 2018;	3.767 / Q1
39.	Ianos, R., Muntean, E., Lazau, R., Babuta, R., Moaca, E.A., Pacurariu, C., Dabici, A., Hulka, I. One-step synthesis of near-infrared reflective brown pigments based on iron-doped lanthanum aluminate, LaAl1-xFexO3, DYES AND PIGMENTS, Volume: 152, Pages: 105-111, ISSN: 0143-7208, eISSN: 1873-3743, 2018;	3.767 / Q1
40.	Ianos, R., Pacurariu, C., Muntean, S.G., Muntean, E., Nistor, M.A., Niznansky, D. Combustion synthesis of iron oxide/carbon nanocomposites, efficient adsorbents for anionic and cationic dyes removal from wastewaters, JOURNAL OF ALLOYS AND COMPOUNDS, Volume: 741, Pages: 1235-1246, ISSN: 0925-8388, eISSN: 1873-4669, 2018;	3.779 / Q1

No.	Article	2017 Impact Factor / Quartile in Category
41.	Khoa L., Declercq, D., Ghaffari, F., Kessal, L., Boncalo, O., Savin, V. Variable-Node-Shift Based Architecture for Probabilistic Gradient Descent Bit Flipping on QC-LDPC Codes, IEEE TRANSACTIONS ON CIRCUITS AND SYSTEMS I-REGULAR PAPERS, Volume: 65, Issue: 7, Pages: 2183-2195, ISSN: 1549-8328, eISSN: 1558-0806, 2018;	2.823 / Q2
42.	Kovacik, J., Marsavina, L., Linul, E. Poisson's Ratio of Closed-Cell Aluminium Foams, MATERIALS, Volume: 11, Issue: 10, Article Number: 1904, PubMed ID: 30301257, ISSN: 1996-1944, 2018;	2.467 / Q2
43.	Lazureanu, C. Integrable Deformations of Three-Dimensional Chaotic Systems, INTERNATIONAL JOURNAL OF BIFURCATION AND CHAOS, Volume: 28, Issue: 5, Article Number: 1850066, ISSN: 0218-1274, eISSN: 1793-6551, 2018;	1.501 / Q2
44.	Li, X., Xu, W., Ye, C.Y., Boldea, I. Comparative Study of Transversal-Flux Permanent-Magnetic Linear Oscillatory Machines for Compressor, IEEE TRANSACTIONS ON INDUSTRIAL ELECTRONICS, Volume: 65, Issue: 9, Pages: 7437-7446, ISSN: 0278-0046, eISSN: 1557-9948, 2018;	7.05 / Q1
45.	Linul, E., Serban, D.A., Marsavina, L. Influence of Cell Topology on Mode I Fracture Toughness of Cellular Structures, PHYSICAL MESOMECHANICS, Volume: 21, Issue: 2 Pages: 178-186, ISSN: 1029-9599, eISSN: 1990-5424, 2018;	2.38 / Q1
46.	Linul, E., Valean, C., Linul, P.A. Compressive Behavior of Aluminum Microfibers Reinforced Semi-Rigid Polyurethane Foams, POLYMERS, Volume: 10, Issue: 12, Article Number: 1298, ISSN: 2073-4360, 2018;	2.935 / Q1
47.	Linul, E., Movahedi, N., Marsavina, L. The temperature and anisotropy effect on compressive behavior of cylindrical closed-cell aluminum-alloy foams, JOURNAL OF ALLOYS AND COMPOUNDS, Volume: 740, Pages: 1172-1179, ISSN: 0925-8388, eISSN: 1873-4669, 2018;	3.779 / Q1
48.	Linul, E., Movahedi, N., Marsavina, L. On the Lateral Compressive Behavior of Empty and Ex-Situ Aluminum Foam-Filled Tubes at High Temperature, MATERIALS, Volume: 11, Issue: 4, Article Number: 554, PubMed ID: 29617300, ISSN: 1996-1944, 2018;	2.467 / Q2
49.	Lupa, L., Cochechi, L., Pode, R., Hulka, I. Phenol adsorption using Aliquat 336 functionalized Zn-Al layered double hydroxide, SEPARATION AND PURIFICATION TECHNOLOGY, Volume: 196, Special Issue: SI, Pages: 82-95, ISSN: 1383-5866, eISSN: 1873-3794, 2018;	3.927 / Q1
50.	Madescu, G., Berwanger, E., Biriescu, M., Mot, M. FAST ANALYSIS OF MMF HARMONICS CONTENT IN THREE-PHASE ELECTRICAL MACHINES, PROCEEDINGS OF THE ROMANIAN ACADEMY SERIES A-MATHEMATICS PHYSICS TECHNICAL SCIENCES INFORMATION SCIENCE, Volume: 19, Issue: 2, Pages: 369-376, ISSN: 1454-9069, 2018;	1.752 / Q2
51.	Maranescu, B., Lupa, L., Mihali, M.T.L., Plesu, N., Maranescu, V., Visa, A. The corrosion inhibitor behavior of iron in saline solution by the action of magnesium carboxyphosphonate, PURE AND APPLIED CHEMISTRY, Volume: 90, Issue: 11, Pages: 1713-1722, ISSN: 0033-4545, eISSN: 1365-3075, 2018;	5.294 / Q1
52.	Maranescu, B., Lupa, L., Visa, A. Heavy metal removal from waste waters by phosphonate metal organic frameworks, PURE AND APPLIED CHEMISTRY, Volume: 90, Issue: 1, Pages: 35-47, ISSN: 0033-4545, eISSN: 1365-3075, 2018;	5.294 / Q1
53.	Marc, S., Kirovski, D., Mircu, C., Hutu, I., Otava, G., Paul, C., Boldura, O.M., Tulcan, C. Serum Protein Electrophoretic Pattern in Neonatal Calves Treated with Clinoptilolite, MOLECULES, Volume: 23, Issue: 6, Article Number: 1278, PubMed ID: 29861463, ISSN: 1420-3049, 2018;	3.098 / Q2
54.	Marinca, B., Marinca, V. Some exact solutions for MHD flow and heat transfer to modified second grade fluid with variable thermal conductivity in the presence of thermal radiation and heat generation/absorption, COMPUTERS & MATHEMATICS WITH APPLICATIONS, Volume: 76, Issue: 6, Pages: 1515-1524, ISSN: 0898-1221, eISSN: 1873-7668, 2018;	1.86 / Q1

No.	Article	2017 Impact Factor / Quartile in Category
55.	Marinca, B., Marinca, V. APPROXIMATE ANALYTICAL SOLUTIONS FOR THIN FILM FLOW OF A FOURTH GRADE FLUID DOWN A VERTICAL CYLINDER, PROCEEDINGS OF THE ROMANIAN ACADEMY SERIES A-MATHEMATICS PHYSICS TECHNICAL SCIENCES INFORMATION SCIENCE, Volume: 19, Issue: 1, Pages: 69-76, ISSN: 1454-9069, 2018;	1.752 / Q2
56.	Marinca, V., Marinca, B. OPTIMAL AUXILIARY FUNCTIONS METHOD FOR NONLINEAR THIN FILM FLOW OF A THIRD GRADE FLUID ON A MOVING BELT, PROCEEDINGS OF THE ROMANIAN ACADEMY SERIES A-MATHEMATICS PHYSICS TECHNICAL SCIENCES INFORMATION SCIENCE, Volume: 19, Issue: 4, Pages: 575-580, ISSN: 1454-9069, 2018;	1.752 / Q2
57.	Mitelea, I., Ghera, C., Bordeasu, I., Craciunescu, C. Assessment of Cavitation Erosion of Gas-Nitrided Cr-Ni-Mo Steels, JOURNAL OF TRIBOLOGY-TRANSACTIONS OF THE ASME, Volume: 140, Issue: 6, Article Number: 061601, ISSN: 0742-4787, eISSN: 1528-8897, 2018;	1.787 / Q2
58.	Moisa, M.E., Poppe, L., Gal, C.A., Bencze, L.C., Irimie, F.D., Paizs, C., Peter, F., Tosa, M.I. Click reaction- aided enzymatic kinetic resolution of secondary alcohols, REACTION CHEMISTRY & ENGINEERING, Volume: 3, Issue: 5, Pages: 790-798, ISSN: 2058-9883, 2018;	4.641 / Q1
59.	Mosoarca, M., Keller, A.I. A complex assessment methodology and procedure for historic roof structures, INTERNATIONAL JOURNAL OF ARCHITECTURAL HERITAGE, Volume: 12, Issue: 4, Special Issue: SI, Pages: 578-598, ISSN: 1558-3058, eISSN: 1558-3066, 2018;	1.345 / Q2
60.	Movahedi, N., Linul, E. Mechanical properties of Light Expanded Clay Aggregated (LECA) filled tubes, MATERIALS LETTERS, Volume: 217, Pages: 194-197, ISSN: 0167-577X, eISSN: 1873-4979, 2018;	2.687 / Q2
61.	Muntean, E., Stoia, M., Pacurariu, C. Facile synthesis, characterization and magnetic properties of manganese ferrite/carbon composites, THERMOCHIMICA ACTA, Volume: 667, Pages: 122-131, ISSN: 0040-6031, eISSN: 1872-762X, 2018;	2.189 / Q2
62.	Murariu, A.C., Cernescu, A.V., Perianu, I.A. The effect of saline environment on the fatigue behaviour of HVOF-sprayed WC-Cr-Ni coatings, SURFACE ENGINEERING, Volume: 34, Issue: 10, Pages: 755-761, ISSN: 0267-0844, eISSN: 1743-2944, 2018;	1.978 / Q2
63.	Murvay, P.S., Groza, B. Security Shortcomings and Countermeasures for the SAE J1939 Commercial Vehicle Bus Protocol, IEEE TRANSACTIONS ON VEHICULAR TECHNOLOGY, Volume: 67, Issue: 5, Pages: 4325-4339, ISSN: 0018-9545, eISSN: 1939-9359, 2018;	4.432 / Q1
64.	Negrea, A., Gabor, A., Davidescu, C.M., Ciopec, M., Negrea, P., Duteanu, N., Barbulescu, A. Rare Earth Elements Removal from Water Using Natural Polymers, SCIENTIFIC REPORTS, Volume: 8, Article Number: 316, PubMed ID: 29321487, ISSN: 2045-2322, 2018;	4.122 / Q1
65.	Negru, R., Serban, D.A., Pop, C., Marsavina, L. Notch effect assessment in a PUR material using a ring shaped specimen, THEORETICAL AND APPLIED FRACTURE MECHANICS, Volume: 97, Pages: 500-506, ISSN: 0167-8442, eISSN: 1872-7638, 2018;	2.215 / Q2
66.	Nelson, J.D.B., Gibberd, A.J., Naformita, C., Kingsbury, N. The locally stationary dual-tree complex wavelet model, STATISTICS AND COMPUTING, Volume: 28, Issue: 6, Pages: 1139-1154, ISSN: 0960-3174, eISSN: 1573-1375, 2018;	1.851 / Q1
67.	Nicoara, M., Buzdugan, D., Locovei, C., Bena, T., Stoica, M. About thermostability of biocompatible Ti-Zr-Ag-Pd-Sn amorphous alloys, JOURNAL OF THERMAL ANALYSIS AND CALORIMETRY, Volume: 133, Issue: 1, Pages: 189-197, ISSN: 1388-6150, eISSN: 1588-2926, 2018;	2.209 / Q2

No.	Article	2017 Impact Factor / Quartile in Category
68.	Niculescu, M., Pascariu, M.C., Muntean, C., Sasca, V., Lupa, L., Milea, M.S., Birzescu, M. Thermal and spectroscopic analysis of Co(II)-Fe(III) polyglyoxylate obtained through the reaction of ethylene glycol with metal nitrates, JOURNAL OF THERMAL ANALYSIS AND CALORIMETRY, Volume: 131, Issue: 1, Pages: 127-136, ISSN: 1388-6150, eISSN: 1588-2926, 2018;	2.209 / Q2
69.	Niyonzima, S., Pop, N., Iacob, F., Larson, A., Orel, A.E., Mezei, J.Z., Chakrabarti, K., Laporta, V., Hassouni, K., Benredjem, D., Bultel, A., Tennyson, J., Reiter, D., Schneider, I.F. Low-energy collisions between electrons and BeD+, PLASMA SOURCES SCIENCE & TECHNOLOGY, Volume: 27, Issue: 2, Article Number: 025015, ISSN: 0963-0252, eISSN: 1361-6595, 2018;	3.939 / Q1
70.	Obrad, C., Gherhes, V. A Human Resources Perspective on Responsible Corporate Behavior. Case Study: The Multinational Companies in Western Romania, SUSTAINABILITY, Volume: 10, Issue: 3, Article Number: 726, ISSN: 2071-1050, 2018;	2.075 / Q2
71.	Oncioiu, I., Grecu, E., Masu, S., Morariu, F., Popa, M. The effect of fly ash on sunflower growth and human health, ENVIRONMENTAL SCIENCE AND POLLUTION RESEARCH, Volume: 25, Issue: 35, Special Issue: SI, Pages: 35548-35554, PubMed ID: 30350152, ISSN: 0944-1344, eISSN: 1614-7499, 2018;	2.8 / Q2
72.	Pana, A., Baloi, A., Molnar-Matei, F. Iterative Method for Determining the Values of the Susceptances of a Balancing Capacitive Compensator, ENERGIES, Volume: 11, Issue: 10, Article Number: 2742, ISSN: 1996-1073, 2018;	2.676 / Q2
73.	Pana, A., Baloi, A., Molnar-Matei, F. From the Balancing Reactive Compensator to the Balancing Capacitive Compensator, ENERGIES, Volume: 11, Issue: 8, Article Number: 1979, ISSN: 1996-1073, 2018;	2.676 / Q2
74.	Petrenko, V.I., Artykulnyi, O.P., Bulavin, L.A., Almasy, L., Garamus, V.M., Ivankov, O.I., Grigoryeva, N.A., Vekas, L., Kopcansky, P., Avdeev, M.V. On the impact of surfactant type on the structure of aqueous ferrofluids., COLLOIDS AND SURFACES A-PHYSICO-CHEMICAL AND ENGINEERING ASPECTS, Volume: 541, Pages: 222-226, ISSN: 0927-7757, eISSN: 1873-4359, 2018;	2.829 / Q2
75.	Pirjan, A., Carutasu, G., Petrosanu, D.M. Designing, Developing, and Implementing a Forecasting Method for the Produced and Consumed Electricity in the Case of Small Wind Farms Situated on Quite Complex Hilly Terrain, ENERGIES, Volume: 11, Issue: 10, Article Number: 2623, ISSN: 1996-1073, 2018;	2.676 / Q2
76.	Pop, C., Ene, R.D. Stability problems and numerical integration on the Lie group $SO(3) \times R-3 \times R-3$ , OPEN MATHEMATICS, Volume: 16, Pages: 219-234, ISSN: 2391-5455, 2018;	0.831 / Q2
77.	Popa, C.A. Global exponential stability of neutral-type octonion-valued neural networks with time-varying delays, NEUROCOMPUTING, Volume: 309, Pages: 117-133, ISSN: 0925-2312, eISSN: 1872-8286, 2018;	3.241 / Q1
78.	Popa, C.A. Global exponential stability of octonion-valued neural networks with leakage delay and mixed delays, NEURAL NETWORKS, Volume: 105, Pages: 277-293, PubMed ID: 29890384, ISSN: 0893-6080, eISSN: 1879-2782, 2018;	7.197 / Q1
79.	Popa, C.A. Learning Algorithms for Quaternion-Valued Neural Networks, NEURAL PROCESSING LETTERS, Volume: 47, Issue: 3, Special Issue: SI, Pages: 949-973, ISSN: 1370-4621, eISSN: 1573-773X, 2018;	1.787 / Q2
80.	Popa, C.A., Kaslik, E. Multistability and multiperiodicity in impulsive hybrid quaternion-valued neural networks with mixed delays, NEURAL NETWORKS, Volume: 99, Pages: 1-18, PubMed ID: 29306800, ISSN: 0893-6080, eISSN: 1879-2782, 2018;	7.197 / Q1
81.	Popov, D. THERMAL STATES IN THE k-GENERALIZED HYPERGEOMETRIC COHERENT STATES REPRESENTATION, PROCEEDINGS OF THE ROMANIAN ACADEMY SERIES A-MATHEMATICS PHYSICS TECHNICAL SCIENCES INFORMATION SCIENCE, Volume: 19, Issue: 3, Pages: 431-438, ISSN: 1454-9069, 2018;	1.752 / Q2

No.	Article	2017 Impact Factor / Quartile in Category
82.	Radac, M.B., Precup, R.E. Data-driven MIMO model-free reference tracking control with nonlinear state-feedback and fractional order controllers, APPLIED SOFT COMPUTING, Volume: 73, Pages: 992-1003, ISSN: 1568-4946, eISSN: 1872-9681, 2018;	3.907 / Q1
83.	Radac, M.B., Precup, R.E., Roman, R.C. Data-driven model reference control of MIMO vertical tank systems with model-free VRFT and Q-Learning, ISA TRANSACTIONS, Volume: 73, Pages: 227-238, PubMed ID: 29325777, ISSN: 0019-0578, eISSN: 1879-2022, 2018;	3.37 / Q1
84.	Radac, M.B., Precup, R.E. Data-driven model-free slip control of anti-lock braking systems using reinforcement Q-learning, NEUROCOMPUTING, Volume: 275, Pages: 317-329, ISSN: 0925-2312, eISSN: 1872-8286, 2018;	3.241 / Q1
85.	Radu, D., Sedmak, A., Bancila, R. Determining the crack acceptability in the welded joints of a wind loaded cylindrical steel shell structure, ENGINEERING FAILURE ANALYSIS, Volume: 91, Pages: 341-353, ISSN: 1350-6307, eISSN: 1873-1961, 2018;	2.157 / Q2
86.	Reisz, E., von Sonntag, C., Tekle-Rottering, A., Naumov, S., Schmidt, W., Schmidt, T.C. Reaction of 2-propanol with ozone in aqueous media, WATER RESEARCH, Volume: 128, Pages: 171-182, PubMed ID: 29102696, ISSN: 0043-1354, 2018;	7.051 / Q1
87.	Roman, M., Roman, D.L., Ostafe, V., Ciorsac, A., Isvoran, A. Computational Assessment of Pharmacokinetics and Biological Effects of Some Anabolic and Androgen Steroids, PHARMACEUTICAL RESEARCH, Volume: 35, Issue: 2, Article Number: UNSP 41, PubMed ID: 29404794, ISSN: 0724-8741, eISSN: 1573-904X, 2018;	3.335 / Q2
88.	Sarac, B., Gammer, C., Deng, L., Park, E., Yokoyama, Y., Stoica, M., Eckert, J. Elastostatic reversibility in thermally formed bulk metallic glasses: nanobeam diffraction fluctuation electron microscopy, NANOSCALE, Volume: 10, Issue: 3, Pages: 1081-1089, PubMed ID: 29271462, ISSN: 2040-3364, eISSN: 2040-3372, 2018;	7.233 / Q1
89.	Sarac, B., Ivanov, Y.P., Chuvilin, A., Schoberl, T., Stoica, M., Zhang, Z.L., Eckert, J. Origin of large plasticity and multiscale effects in iron-based metallic glasses, NATURE COMMUNICATIONS, Volume: 9, Article Number: 1333, PubMed ID: 29626189, ISSN: 2041-1723, 2018;	12.353 / Q1
90.	Sarbu, I., Dorca, A. A comprehensive review of solar thermoelectric cooling systems, INTERNATIONAL JOURNAL OF ENERGY RESEARCH, Volume: 42, Issue: 2, Pages: 395-415, ISSN: 0363-907X, eISSN: 1099-114X, Published: 2018;	3.009 / Q1
91.	Sarbu, I., Sebarchievici, C. A Comprehensive Review of Thermal Energy Storage, SUSTAINABILITY, Volume: 10, Issue: 1, Article Number: 191, ISSN: 2071-1050, Published: 2018;	2.075 / Q2
92.	Stanciu, E.M., Pascu, A., Roata, I.C., Croitoru, C., Tiorean, M., Rosca, J.M., Hulka, I. Solar radiation synthesis of functional carbonaceous materials using Al <sub>2</sub> O <sub>3</sub> /TiO <sub>2</sub> -Cu-HA doped catalyst, APPLIED SURFACE SCIENCE, Volume: 438, Pages: 33-40, ISSN: 0169-4332, eISSN: 1873-5584, 2018;	4.439 / Q1
93.	Stoica, F., Chirita-Emandi, A., Andreescu, N., Stanciu, A., Zimbru, C.G., Puiu, M. Clinical relevance of retinal structure in children with laser-treated retinopathy of prematurity versus controls - using optical coherence tomography, ACTA OPHTHALMOLOGICA, Volume: 96, Issue: 2, Pages: e222-e228, PubMed ID: 28926210, ISSN: 1755-375X, eISSN: 1755-3768, 2018;	3.324 / Q1
94.	Susan-Resiga, D., Barvinschi, P. Correlation of rheological properties of ferrofluid-based magnetorheological fluids using the concentration-magnetization superposition, JOURNAL OF RHEOLOGY, Volume: 62, Issue: 3, Pages: 739-752, ISSN: 0148-6055, 2018;	2.969 / Q1

No.	Article	2017 Impact Factor / Quartile in Category
95.	Svera, P., Niznansky, D., Stefanut, M.N., Ursu, D., Sfirloaga, P., Dabici, A., Taranu, B.O., Putz, A.M., Serban, V.A. Studies on the hydrothermal synthesis of CdxZn1-xS compounds, PROCESSING AND APPLICATION OF CERAMICS, Volume: 12, Issue: 3, Pages: 288-295, ISSN: 1820-6131, eISSN: 2406-1034, 2018;	1.152 / Q2
96.	Taherishargh, M., Linul, E., Broxtermann, S., Fiedler, T. The mechanical properties of expanded perlite-aluminium syntactic foam at elevated temperatures, JOURNAL OF ALLOYS AND COMPOUNDS, Volume: 737, Pages: 590-596, ISSN: 0925-8388, eISSN: 1873-4669, 2018;	3.779 / Q1
97.	Tigan, G., Analysis of Degenerate Fold-Hopf Bifurcation in a Three-Dimensional Differential System, QUALITATIVE THEORY OF DYNAMICAL SYSTEMS, Volume: 17, Issue: 2, Pages: 387-402, ISSN: 1575-5460, eISSN: 1662-3592, 2018;	1.019 / Q1
98.	Todea, A., Aparaschivei, D., Badea, V., Boeriu, C.G., Peter, F. Biocatalytic Route for the Synthesis of Oligoesters of Hydroxy-Fatty acids and E-Caprolactone, BIOTECHNOLOGY JOURNAL, Volume: 13, Issue: 6, Special Issue: SI, Article Number: 1700629, ISSN: 1860-6768, eISSN: 1860-7314, 2018;	3.507 / Q2
99.	Todea, A., Borza, P., Cimporescu, A., Paul, C., Peter, F. Continuous kinetic resolution of aliphatic and aromatic secondary alcohols by sol-gel entrapped lipases in packed bed bioreactors, CATALYSIS TODAY, Volume: 306, Pages: 223-232, ISSN: 0920-5861, eISSN: 1873-4308, 2018;	4.667 / Q1
100.	Topirceanu, A., Udrescu, M., Udrescu, L., Ardelean, C., Dan, R., Reisz, D., Mihaicuta, S. SAS score: Targeting high-specificity for efficient population-wide monitoring of obstructive sleep apnea, PLOS ONE, Volume: 13, Issue: 9, Article Number: e0202042, PubMed ID: 30183715, ISSN: 1932-6203, 2018;	2.766 / Q1
101.	Topirceanu, A., Udrescu, M., Marculescu, R. Weighted Betweenness Preferential Attachment: A New Mechanism Explaining Social Network Formation and Evolution, SCIENTIFIC REPORTS, Volume: 8, Article Number: 10871, PubMed ID: 30022079, ISSN: 2045-2322, 2018;	4.122 / Q1
102.	Topirceanu, A. Competition-Based Benchmarking of Influence Ranking Methods in Social Networks, COMPLEXITY, Article Number: 4562609, ISSN: 1076-2787, eISSN: 1099-0526, 2018;	1.829 / Q2
103.	Truong, N.L.T., Savin, V., Le, K., Declercq, D., Ghaffari, F., Boncalo, O. Analysis and Design of Cost-Effective, High-Throughput LDPC Decoders, IEEE TRANSACTIONS ON VERY LARGE SCALE INTEGRATION (VLSI) SYSTEMS, Volume: 26, Issue: 3, Pages: 508-521, ISSN: 1063-8210, eISSN: 1557-9999, 2018;	1.744 / Q2
104.	Tutelea, L.N., Staudt, T., Popa, A.A., Hoffmann, W., Boldea, I. Line Start 1 Phase-Source Split Phase Capacitor Cage-PM Rotor-RelSyn Motor: Modeling, Performance, and Optimal Design With Experiments, IEEE TRANSACTIONS ON INDUSTRIAL ELECTRONICS, Volume: 65, Issue: 2, Pages: 1772-1780, ISSN: 0278-0046, eISSN: 1557-9948, 2018;	7.05 / Q1
105.	Ungureanu, V., Kotelko, M., Karmazyn, A., Dubina, D. Plastic mechanisms of thin-walled cold-formed steel members in eccentric compression, THIN-WALLED STRUCTURES, Volume: 128, Special Issue: SI, Pages: 184-192, ISSN: 0263-8231, eISSN: 1879-3223, 2018;	2.881 / Q1
106.	Ursu, D., Miclau, N., Miclau, M. n-Type Conductivity of Cu2O Thin Film Prepared in Basic Aqueous Solution Under Hydrothermal Conditions, ELECTRONIC MATERIALS LETTERS, Volume: 14, Issue: 4, Pages: 405-412, ISSN: 1738-8090, eISSN: 2093-6788, 2018;	2.882 / Q2
107.	Vasilescu, C., Latikka, M., Knudsen, K.D., Garamus, V.M., Socoliuc, V., Turcu, R., Tombacz, E., Susan-Resiga, D., Ras, R.H.A., Vekas, L. High concentration aqueous magnetic fluids: structure, colloidal stability, magnetic and flow properties, SOFT MATTER, Volume: 14, Issue: 32, Pages: 6648-6666, PubMed ID: 30035279, ISSN: 1744-683X, eISSN: 1744-6848, 2018;	3.709 / Q1

No.	Article	2017 Impact Factor / Quartile in Category
108.	Vasilie, S., Manea, F., Baci, A., Pop, A. Dual use of boron-doped diamond electrode in antibiotics-containing water treatment and process control, PROCESS SAFETY AND ENVIRONMENTAL PROTECTION, Volume: 117, Pages: 446-453, ISSN: 0957-5820, eISSN: 1744-3598, 2018;	3.441 / Q1
109.	Vlascici, D., Plesu, N., Fagadar-Cosma, G., Lascu, A., Petric, M., Crisan, M., Belean, A., Fagadar-Cosma, E. Potentiometric Sensors for Iodide and Bromide Based on Pt(II)-Porphyrin, SENSORS, Volume: 18, Issue: 7, Article Number: 2297, PubMed ID: 30012951, ISSN: 1424-8220, 2018;	2.475 / Q2
110.	Vlazan, P., Stoia, M. Structural and magnetic properties of CoFe <sub>2</sub> O <sub>4</sub> nanopowders, prepared using a modified Pechini method, CERAMICS INTERNATIONAL, Volume: 44, Issue: 1, Pages: 530-536, ISSN: 0272-8842, eISSN: 1873-3956, 2018;	3.057 / Q1
111.	Wang, X.H., Inoue, A., Zhao, J.F., Kong, F.L., Zhu, S.L., Kaban, I., Stoica, M., Oswald, S., Fan, C., Shalaan, E., Al-Marzouki, F., Eckert, J., Yin, F.X., Li, Q. Liquid ejection temperature dependence of structure and glass transition behavior for rapidly solidified Zr-Al-M (M=Ni, Cu or Co) ternary glassy alloys, JOURNAL OF ALLOYS AND COMPOUNDS, Volume: 739, Pages: 1104-1114, ISSN: 0925-8388, eISSN: 1873-4669, 2018;	3.779 / Q1
112.	Yousefi-Talouki, A., Pescetto, P., Pellegrino, G., Boldea, I. Combined Active Flux and High-Frequency Injection Methods for Sensorless Direct-Flux Vector Control of Synchronous Reluctance Machines, IEEE TRANSACTIONS ON POWER ELECTRONICS, Volume: 33, Issue: 3, Pages: 2447-2457, ISSN: 0885-8993, eISSN: 1941-0107, 2018;	6.812 / Q1
113.	Zub, C.I., Stratan, A., Dogariu, A., Dubina, D. DEVELOPMENT OF A FINITE ELEMENT MODEL FOR A BUCKLING RESTRAINED BRACE, PROCEEDINGS OF THE ROMANIAN ACADEMY SERIES A-MATHEMATICS PHYSICS TECHNICAL SCIENCES INFORMATION SCIENCE, Volume: 19, Issue: 4, Pages: 581-588, ISSN: 1454-9069, 2018.	1.752 / Q2

\*The data was obtained from Web of Science - Clarivate Analytics in 13 May 2019





# Papers in ISI Journals



1. Abdullah, A.D., Castro-Gama, M.E., Popescu, I., van der Zaag, P., Karim, U., Al Suhail, Q. Optimization of water allocation in the Shatt al-Arab River under different salinity regimes and tide impact, *HYDROLOGICAL SCIENCES JOURNAL-JOURNAL DES SCIENCES HYDROLOGIQUES*, Volume: 63, Issue: 4, Pages: 646-656, ISSN: 0262-6667, eISSN: 2150-3435, 2018;
2. Albulescu, C.T., Pepin, D. Monetary Integration, Money-Demand Stability, and the Role of Monetary Overhang in Forecasting Inflation in CEE Countries, *JOURNAL OF ECONOMIC INTEGRATION*, Volume: 33, Issue: 4, Pages: 841-879, ISSN: 1225-651X, eISSN: 1976-5525, 2018;
3. Albulescu, C.T., Ionescu, A.M. The long-run impact of monetary policy uncertainty and banking stability on inward FDI in EU countries, *RESEARCH IN INTERNATIONAL BUSINESS AND FINANCE*, Volume: 45, Pages: 72-81, ISSN: 0275-5319, eISSN: 1878-3384, 2018;
4. Albulescu, C.T., Aubin, C., Goyeau, D., Tiwari, A.K. Extreme co-movements and dependencies among major international exchange rates: A copula approach, *QUARTERLY REVIEW OF ECONOMICS AND FINANCE*, Volume: 69, Pages: 56-69, ISSN: 1062-9769, eISSN: 1878-4259, 2018;
5. Albulescu, C.T., Miclea, S., Suci, S.S., Tamasila, M. Firm-level investment in the extractive industry from CEE countries: the role of macroeconomic uncertainty and internal conditions, *EURASIAN BUSINESS REVIEW*, Volume: 8, Issue: 2, Pages: 193-208, ISSN: 1309-4297, eISSN: 2147-4281, 2018;
6. Albulescu, C.T., Tiwari, A.K. Unemployment persistence in EU countries: new evidence using bounded unit root tests, *APPLIED ECONOMICS LETTERS*, Volume: 25, Issue: 12, Pages: 807-810, ISSN: 1350-4851, eISSN: 1466-4291, 2018;
7. Alexa, V., Kiss, I. Experimental Testson the Plasticity and Deformability Characteristics of Several Stainless Steel Grades used for Hydro-Pneumatic Equipment's Manufacturing, *ACTA POLYTECHNICA HUNGARICA*, Volume: 15, Issue: 8, Pages: 121-139, ISSN: 1785-8860, 2018;
8. Aliha, M.R.M., Linul, E., Bahmani, A., Marsavina, L. Experimental and theoretical fracture toughness investigation of PUR foams under mixed mode I plus III loading, *POLYMER TESTING*, Volume: 67, Pages: 75-83, ISSN: 0142-9418, eISSN: 1873-2348, 2018;
9. Ancuti, C.O., Ancuti, C., De Vleeschouwer, C., Bekaert, P. Color Balance and Fusion for Underwater Image Enhancement, *IEEE TRANSACTIONS ON IMAGE PROCESSING*, Volume: 27, Issue: 1, Pages: 379-393, PubMed ID: 28981416, ISSN: 1057-7149, eISSN: 1941-0042, 2018;
10. Ancuti, C., Ancuti, C.O., de Vleeschouwer, C., Sbert, M. Decolorization by Fusion, *IEEE ACCESS*, Volume: 6, Pages: 64071-64084, ISSN: 2169-3536, 2018;
11. Arvinti, B., Isar, A., Stolz, R., Costache, M. EFFECTS OF COMBINING STEIN'S UNBIASED RISK ESTIMATE AND WAVELETS FOR DENOISING MAGNETOCARDIOGRAMS, *REVUE ROUMAINE DES SCIENCES TECHNIQUES-SERIE ELECTROTECHNIQUE ET ENERGETIQUE*, Volume: 63, Issue: 3, Pages: 344-349, ISSN: 0035-4066, 2018;
12. Baloi, M.A., Crucean, C., Popescu, D. Scalar pair production in a magnetic field in de Sitter universe, *EUROPEAN PHYSICAL JOURNAL C*, Volume: 78, Issue: 5, Article Number: 398, ISSN: 1434-6044, eISSN: 1434-6052, 2018;
13. Belega, D., Petri, D. Effect of windowing and noise on the amplitude and phase estimators returned by the Taylor-based Weighted Least Squares, *DIGITAL SIGNAL PROCESSING*, Volume: 83, Pages: 202-213, ISSN: 1051-2004, eISSN: 1095-4333, 2018;
14. Belega, D., Petri, D., Dallet, D. Accurate amplitude and phase estimation of noisy sine-waves via two-point interpolated DTFT algorithms, *MEASUREMENT*, Volume: 127, Pages: 89-97, ISSN: 0263-2241, eISSN: 1873-412X, 2018;
15. Belega, D., Petri, D., Dallet, D. Amplitude and Phase Estimation of Real-Valued Sine Wave via Frequency-Domain Linear Least-Squares Algorithms, *IEEE TRANSACTIONS ON INSTRUMENTATION AND MEASUREMENT*, Volume: 67, Issue: 5, Special Issue: SI, Pages: 1065-1077, ISSN: 0018-9456, eISSN: 1557-9662, 2018;
16. Belega, D., Petri, D., Dallet, D. INFLUENCE OF THE SPECTRAL IMAGE COMPONENT ON THE AMPLITUDE AND PHASE ESTIMATORS PROVIDED BY THE INTERPOLATED DFT METHOD, *PROCEEDINGS OF THE ROMANIAN ACADEMY SERIES A-MATHEMATICS PHYSICS TECHNICAL SCIENCES INFORMATION SCIENCE*, Volume: 19, Issue: 2, Pages: 377-384, ISSN: 1454-9069, 2018;
17. Belega, D., Petri, D., Dallet, D. Accurate frequency estimation of a noisy sine-wave by means of an interpolated discrete-time Fourier transform algorithm, *MEASUREMENT*, Volume: 116, Pages: 685-691, ISSN: 0263-2241, eISSN: 1873-412X, 2018;
18. Berei, E., Muntean, C., Stefanescu, O., Niculescu, M., Stefanescu, M. Preparation of CuCr2O4 nanopowders using two different chromium sources, *JOURNAL OF THERMAL ANALYSIS AND CALORIMETRY*, Volume: 131, Issue: 1, Pages: 137-144, ISSN: 1388-6150, eISSN: 1588-2926, 2018;

19. Berei, E., Stefanescu, O., Muntean, C., Vlase, T., Taranu, B.O., Dabici, A., Stefanescu, M. A novel route for the preparation of CoCr204/SiO2 nanocomposite starting from Co(II)-Cr(III) carboxylate complex combinations, *JOURNAL OF MATERIALS SCIENCE*, Volume: 53, Issue: 6, Pages: 4159-4172, ISSN: 0022-2461, eISSN: 1573-4803, 2018;
20. Binzar, T., Lazureanu, C. Wold-Type Decompositions for a Commutative Pair of Noncommutative Semigroups of Isometries, *BULLETIN OF THE MALAYSIAN MATHEMATICAL SCIENCES SOCIETY*, Volume: 41, Issue: 2, Pages: 1139-1150, ISSN: 0126-6705, eISSN: 2180-4206, 2018;
21. Bistran, D.A., Navon, I.M. Efficiency of randomised dynamic mode decomposition for reduced order modelling, *INTERNATIONAL JOURNAL OF COMPUTATIONAL FLUID DYNAMICS*, Volume: 32, Issue: 2-3, Special Issue: SI, Pages: 88-103, ISSN: 1061-8562, eISSN: 1029-0257, 2018;
22. Bojan-Dragos, C.A., Radac, M.B., Precup, R.E., Hedrea, E.L., Tanasoiu, O.M. Gain-Scheduling Control Solutions for Magnetic Levitation Systems, *ACTA POLYTECHNICA HUNGARICA*, Volume: 15, Issue: 5, Special Issue: SI, Pages: 89-108, ISSN: 1785-8860, 2018;
23. Boldea, I., Tutelea, L.N., Xu, W., Pucci, M. Linear Electric Machines, Drives, and MAGLEVs: An Overview, *IEEE TRANSACTIONS ON INDUSTRIAL ELECTRONICS*, Volume: 65, Issue: 9, Pages: 7504-7515, ISSN: 0278-0046, eISSN: 1557-9948, 2018;
24. Boncalo, O., Kolumban-Antal, G., Declercq, D., Savin, V. Code-design for efficient pipelined layered LDPC decoders with bank memory organization, *MICROPROCESSORS AND MICROSYSTEMS*, Volume: 63, Pages: 216-225, ISSN: 0141-9331, eISSN: 1872-9436, 2018;
25. Boran, S., Nitu, S. ESTER PLASTICIZERS BASED ON FATTY ACIDS FROM SOYPEAN OIL USED IN PELICULOGEN COMPOSITIONS, *STUDIA UNIVERSITATIS BABES-BOLYAI CHEMIA*, Volume: 63, Issue: 1, Pages: 63-72, ISSN: 1224-7154, 2018;
26. Bordeasu, I., Circiumaru, A., Popoviciu, M., Lazar, I., Badarau, R., Groza, I. Cavitation Erosion Behavior on Thin Films of Polymer Blends Deposited Over Bronze Surfaces, *MATERIALE PLASTICE*, Volume: 55, Issue: 3, Pages: 286-290, ISSN: 0025-5289, 2018;
27. Bota, C., Caruntu, B., Pasca, M.S., Lapadat, M. Optimal Control Based on the Polynomial Least Squares Method, *MATHEMATICAL PROBLEMS IN ENGINEERING*, Article Number: 9454160, ISSN: 1024-123X, eISSN: 1563-5147, 2018;
28. Bucos, M., Dragulescu, B. Predicting Student Success Using Data Generated in Traditional Educational Environments, *TEM JOURNAL-TECHNOLOGY EDUCATION MANAGEMENT INFORMATICS*, Volume: 7, Issue: 3, Pages: 617-625, ISSN: 2217-8309, eISSN: 2217-8333, 2018;
29. Buse, C., Khan, A., Nguyen, L.T., O'Regan, D., Rahmat, G. Asymptotic behavior of discrete evolution families in Banach spaces, *APPLICABLE ANALYSIS*, Volume: 97, Issue: 2, Pages: 160-178, ISSN: 0003-6811, eISSN: 1563-504X, 2018;
30. Buse, C., Nguyen, L.T., O'Regan, D. GLOBAL AND LOCAL VERSIONS FOR A PHONG VU THEOREM FOR PERIODIC EVOLUTION FAMILIES IN HILBERT SPACES, *ELECTRONIC JOURNAL OF DIFFERENTIAL EQUATIONS*, Article Number: 188, ISSN: 1072-6691, 2018;
31. Buta, I., Ardelean, A., Cseh, L., Badea, V., Manea, F., Gal, E., Lonneck, P., Hey-Hawkins, E., Costisor, O. NEW MONONUCLEAR COBALT(III) AND MANGANESE(III) COMPLEXES CONTAINING A HEXADENTATE SCHIFF BASE LIGAND, *REVUE ROUMAINE DE CHIMIE*, Volume: 63, Issue: 5-6, Pages: 515-519, ISSN: 0035-3930, 2018;
32. Butnariu, I., Constantin, N., Dobrescu, C., Heput, T. Research on the Recycling of Pulverulent Waste from the Ferrous and Non-Ferrous Industry in Order to Reduced the Pollution, *REVISTA DE CHIMIE*, Volume: 69, Issue: 5, Pages: 1066-1070, ISSN: 0034-7752, 2018;
33. Calinoiu, D., Stefu, N., Boata, R., Blaga, R., Pop, N., Paulescu, E., Sabadus, A., Paulescu, M. Parametric modeling: A simple and versatile route to solar irradiance, *ENERGY CONVERSION AND MANAGEMENT*, Volume: 164, Pages: 175-187, ISSN: 0196-8904, eISSN: 1879-2227, 2018;
34. Calinoiu, D.G., Trif-Tordai, G., Ionel, I., Cioabla, A.E. SUN PHOTOMETER - REMOTE SENSING FOR AEROSOL ASSESSMENT, *JOURNAL OF ENVIRONMENTAL PROTECTION AND ECOLOGY*, Volume: 19, Issue: 2, Pages: 462-470, ISSN: 1311-5065, 2018;
35. Canjau, S., Todea, D.C.M., Sinescu, C., Pricop, M.O., Duma, V.F. Fluorescence influence on screening decisions for oral malignant lesions, *ROMANIAN JOURNAL OF MORPHOLOGY AND EMBRYOLOGY*, Volume: 59, Issue: 1, Pages: 203-209, PubMed ID: 29940629, ISSN: 1220-0522, 2018;
36. Cernicova, M., Gherhes, V. Perceptions of Romanian students on uses and value of educational resources shared via ICT. Case study: Politehnica University Timisoara, *BRAIN-BROAD RESEARCH IN ARTIFICIAL INTELLIGENCE AND NEUROSCIENCE*, Volume: 9, Issue: 1, Pages: 163-172, ISSN: 2067-3957, 2018;
37. Chesoa, A., Stratan, A., Dubina, D. Design implementation of re-centring dual eccentrically braced frames with removable links, *SOIL DYNAMICS AND EARTHQUAKE ENGINEERING*, Volume: 112, Pages: 174-184, ISSN: 0267-7261, eISSN: 1879-341X, 2018;

38. Chis, V., Barbulescu, C., Kilyeni, S., Dzitac, S. ANN based Short-Term Load Curve Forecasting, INTERNATIONAL JOURNAL OF COMPUTERS COMMUNICATIONS & CONTROL, Volume: 13, Issue: 6, Pages: 938-955, ISSN: 1841-9836, eISSN: 1841-9844, 2018;
39. Cioabla, A.E., Bandur, G.N., Trif-Tordai, G., Rusu, G.I., Popescu, F., Vetres, I. THERMOCHEMICAL PROPERTIES AND KINETIC STUDY OF RESIDUAL WATERS USED INSIDE ANAEROBE FERMENTATION FOR BIOGAS PRODUCTION, JOURNAL OF ENVIRONMENTAL PROTECTION AND ECOLOGY, Volume: 19, Issue: 3, Pages: 1225-1236, ISSN: 1311-5065, 2018;
40. Cioabla, A.E., Popescu, F., Trif-Tordai, G., Dumitrel, A.G., Oprisa-Stanescu, P.D., Lelea, D. SUSTAINABLE DEVELOPMENT OF ROMANIAN CITIES THROUGH BIOGAS PRODUCTION FROM MUNICIPAL WASTES AND APPLICATION IN CO-COMBUSTION PROCESSES, THERMAL SCIENCE, Volume: 22, Issue: 2, Pages: 1071-1076, ISSN: 0354-9836, eISSN: 2334-7163, 2018;
41. Cioroiu, D.R., Parvulescu, O.C., Dobre, T., Raducanu, C., Koncsag, C.I., Mocanu, A., Duteanu, N. Slow Pyrolysis of Cystoseira Barbata Brown Macroalgae, REVISTA DE CHIMIE, Volume: 69, Issue: 3, Pages: 553-556, ISSN: 0034-7752, 2018;
42. Circu, M., Bunge, A., Vasilescu, C., Porav, S., Nan, A. Non-catalytic, solvent-free synthesis of poly(tartronic-co-glycolic acid) as a versatile coating for different surfaces, POLYMER INTERNATIONAL, Volume: 67, Issue: 2, Pages: 212-219, ISSN: 0959-8103, eISSN: 1097-0126, 2018;
43. Ciurdariu, L. ABOUT SOME POWER SERIES INEQUALITIES AND TRACE INEQUALITIES, JOURNAL OF SCIENCE AND ARTS, Issue: 2, Pages: 421-438, ISSN: 1844-9581, 2018;
44. Cochechi, L., Lupa, L., Gheju, M., Golban, A., Lazau, R., Pode, R. Zn-Al-CO<sub>3</sub> layered double hydroxides prepared from a waste of hot-dip galvanizing process, CLEAN TECHNOLOGIES AND ENVIRONMENTAL POLICY, Volume: 20, Issue: 5, Pages: 1105-1112, ISSN: 1618-954X, eISSN: 1618-9558, 2018;
45. Constantin, A.T., Ghitescu, M.A., Lazar, G.I., Nicoara, S.V. Fish Ladder Numerical Modelling, REVISTA DE CHIMIE, Volume: 69, Issue: 3, Pages: 591-596, ISSN: 0034-7752, 2018;
46. Corici, L.N., Pana, A.M., Shova, S., Haidu, D., Badea, V., Apostu, M., Buta, I., Szerb, E.I., Costisor, O., Cseh, L. SYNTHESIS AND INVESTIGATION OF 2-(HYDROXYBENZYLIDENE)-5-METHYLCYCLOHEXAN-1-ONE, REVUE ROUMAINE DE CHIMIE, Volume: 63, Issue: 7-8, Pages: 743-+, ISSN: 0035-3930, 2018;
47. Costea, L.V., Bica, K., Fafilek, G., Mihovilovic, M.D. Electrochemical properties of halogenated benzylidenehydrazino-pyrazoles in various imidazolium-based ionic liquids, MONATSHFTE FUR CHEMIE, Volume: 149, Issue: 4, Special Issue: SI, Pages: 823-831, ISSN: 0026-9247, eISSN: 1434-4475, 2018;
48. Craciunescu, C., Mitelea, I. Combined effects in quasisimilar NiTi joints manufactured by pulsed laser welding, MATERIALS SCIENCE AND ENGINEERING A-STRUCTURAL MATERIALS PROPERTIES MICROSTRUCTURE AND PROCESSING, Volume: 737, Pages: 364-372, ISSN: 0921-5093, eISSN: 1873-4936, 2018;
49. Crispini, A., Cretu, C., Aparaschivei, D., Andelescu, A.A., Sasca, V., Badea, V., Aiello, I., Szerb, E.I., Costisor, O. Influence of the counterion on the geometry of Cu(I) and Cu(II) complexes with 1,10-phenanthroline, INORGANICA CHIMICA ACTA, Volume: 470, Special Issue: SI, Pages: 342-351, ISSN: 0020-1693, eISSN: 1873-3255, 2018;
50. Curiac, D.I., Banius, O., Volosencu, C., Curiac, C.D. Novel Bioinspired Approach Based on Chaotic Dynamics for Robot Patrolling Missions with Adversaries, ENTROPY, Volume: 20, Issue: 5, Article Number: UNSP 378, ISSN: 1099-4300, 2018;
51. Daianu, D.M., Mindruta, C. Arithmetically homogeneous functions: characterizations, stability and hyperstability, AEQUATIONES MATHEMATICAE, Volume: 92, Issue: 6, Pages: 1061-1077, ISSN: 0001-9054, eISSN: 1420-8903, 2018;
52. Daianu, D.M. Taylor type formula with Frchet polynomials, AEQUATIONES MATHEMATICAE, Volume: 92, Issue: 4, Pages: 695-707, ISSN: 0001-9054, eISSN: 1420-8903, 2018;
53. Dan, M., Kellenberger, A., Vaszilcsin, N., Duteanu, N. VOLTAMMETRIC STUDIES OF YBaCo<sub>2</sub>O<sub>5</sub> IN ALKALINE AQUEOUS SOLUTION, ENVIRONMENTAL ENGINEERING AND MANAGEMENT JOURNAL, Volume: 17, Issue: 12, Pages: 2807-2814, ISSN: 1582-9596, eISSN: 1843-3707, 2018;
54. Dan, S., Bob, C., Badea, C., Dan, D., Florescu, C., Cotoarba, L., Pode, V., Gruin, A. Carbon Fiber Reinforced Polymers Used for Strengthening of Existing Reinforced Concrete Structures, MATERIALE PLASTICE, Volume: 55, Issue: 4, Pages: 536-540, ISSN: 0025-5289, 2018;
55. de Miranda, S., Melchionda, D., Ungureanu, V., Dubina, D. A modified ECBL approach for cold-formed steel rack section members, THIN-WALLED STRUCTURES, Volume: 130, Pages: 47-56, ISSN: 0263-8231, eISSN: 1879-3223, 2018;

56. Declercq, D., Savin, V., Boncalo, O., Ghaffari, F. An Imprecise Stopping Criterion Based on In-Between Layers Partial Syndromes, *IEEE COMMUNICATIONS LETTERS*, Volume: 22, Issue: 1, Pages: 13-16, ISSN: 1089-7798, eISSN: 1558-2558, 2018;
57. Diudea, M.V., Pirvan-Moldovan, A., Pop, R., Medeleanu, M. Energy of Graphs and Remote Graphs in Hypercubes, Rhombellanes and Fullerenes, *MATCH-COMMUNICATIONS IN MATHEMATICAL AND IN COMPUTER CHEMISTRY*, Volume: 80, Issue: 3, Pages: 835-852, ISSN: 0340-6253, 2018;
58. Dulcea, D., Ionel, I., Bisorca, D., Balogh, R.M., Ungureanu, C.I. METHOD FOR DETERMINING THE POINT IMPACT OF A POLLUTING SOURCE UPON AIR QUALITY, *JOURNAL OF ENVIRONMENTAL PROTECTION AND ECOLOGY*, Volume: 19, Issue: 4, Pages: 1452-1461, ISSN: 1311-5065, 2018;
59. Duma, V.F., Schitea, A. LASER SCANNERS WITH ROTATIONAL RISLEY PRISMS: EXACT SCAN PATTERNS, *PROCEEDINGS OF THE ROMANIAN ACADEMY SERIES A-MATHEMATICS PHYSICS TECHNICAL SCIENCES INFORMATION SCIENCE*, Volume: 19, Issue: 1, Pages: 53-60, ISSN: 1454-9069, 2018;
60. Dumitru, C., Cernescu, A., Eremici, I., Bortun, C.M., Achiriloaiei, D. Fatigue Behavior of Two Acrylic Denture Base Resins, *MATERIALE PLASTICE*, Volume: 55, Issue: 4, Pages: 567-570, ISSN: 0025-5289, 2018;
61. Dumitru, R., Manea, F., Pacurariu, C., Lupa, L., Pop, A., Cioabla, A., Surdu, A., Ianculescu, A. Synthesis, Characterization of Nanosized ZnCr2O4 and Its Photocatalytic Performance in the Degradation of Humic Acid from Drinking Water, *CATALYSTS*, Volume: 8, Issue: 5, Article Number: 210, ISSN: 2073-4344, 2018;
62. Dunca, A.M., Badaluta-Minda, C. The Determination of the Maximum Runoff in the Representative and Experimental Hydrographical Basin of Sebes River (Banat, Romania), *ROZNIK OCHRONA SRODOWISKA*, Volume: 20, Pages: 54-72, Part: 1, ISSN: 1506-218X, 2018;
63. Enache, A.F., Dan, M.L., Vaszilcsin, N. Electrochemical Oxidation of Sulphite in Neutral Media on Platinum Anode, *INTERNATIONAL JOURNAL OF ELECTROCHEMICAL SCIENCE*, Volume: 13, Issue: 5, Pages: 4466-4478, ISSN: 1452-3981, 2018;
64. Ene, R.D., Bordeasu, I., Negrea, R.I. Analytic approximate solutions to the chemically reactive solute transfer problem with partial slip in the flow of a viscous fluid over an exponentially stretching sheet with suction/blowing, *OPEN ENGINEERING*, Volume: 8, Issue: 1, Pages: 227-242, ISSN: 2391-5439, 2018;
65. Fierascu, S.I., Parvu, M., Topirceanu, A., Udrescu, M. EXPLORING PARTY SWITCHING IN THE POST-1989 ROMANIAN POLITICIANS NETWORK FROM A COMPLEX NETWORK PERSPECTIVE, *ROMANIAN JOURNAL OF POLITICAL SCIENCE*, Volume: 18, Issue: 1, Pages: 108-136, ISSN: 1582-456X, 2018;
66. Gabor, A., Zaharia, C., Todericiu, V., Suzhanek, C., Cojocariu, A.C., Duma, V.F., Sticlaru, C., Negrutiu, M.L., Antoniac, I.V., Sinescu, C. Adhesion of Scaffolds with Implants to the Mandibular Bone with a Defect, *MATERIALE PLASTICE*, Volume: 55, Issue: 3, Pages: 393-397, ISSN: 0025-5289, 2018;
67. Gheju, M. Progress in Understanding the Mechanism of Cr-VI Removal in Fe-O-Based Filtration Systems, *WATER*, Volume: 10, Issue: 5, Article Number: 651, ISSN: 2073-4441, Published: 2018;
68. Gherhes, V., Obrad, C. Technical and Humanities Students' Perspectives on the Development and Sustainability of Artificial Intelligence (AI), *SUSTAINABILITY*, Volume: 10, Issue: 9, Article Number: 3066, ISSN: 2071-1050, 2018;
69. Gherman, V.D., Molnar, P., Motoc, M., Negrea, A. Pretreatments Testing of High Biodiversity Inocula with Simultaneous Biohydrogen Production and Wastewater Treatment, *REVISTA DE CHIMIE*, Volume: 69, Issue: 4, Pages: 806-808, ISSN: 0034-7752, 2018;
70. Golban, A., Cochechi, L., Lazau, R., Lupa, L., Pode, R. Iron ions reclaiming from sludge resulted from hot-dip galvanizing process, as Mg3Fe-layered double hydroxide used in the degradation process of organic dyes, *DESALINATION AND WATER TREATMENT*, Volume: 131, Pages: 317-327, ISSN: 1944-3994, eISSN: 1944-3986, 2018;
71. Golban, D.M., Negru, R., Suzhaneic, C., Negrutiu, M.L., Marsavina, L., Duma, V.F., Sinescu, C., Porojan, L. Flash-Free Orthodontic Adhesive System Bonded on CAD/CAM Produced Resin Restorations, *MATERIALE PLASTICE*, Volume: 55, Issue: 4, Pages: 606-608, ISSN: 0025-5289, 2018;
72. Gontean, A., Lica, S., Bularka, S., Szabo, R., Lascu, D. A Novel High Accuracy PV Cell Model Including Self Heating and Parameter Variation, *ENERGIES*, Volume: 11, Issue: 1, Article Number: 36, ISSN: 1996-1073, 2018;
73. Grecu, E., Aceleanu, M.I., Albulescu, C.T. The economic, social and environmental impact of shale gas exploitation in Romania: A cost-benefit analysis, *RENEWABLE & SUSTAINABLE ENERGY REVIEWS*, Volume: 93, Pages: 691-700, ISSN: 1364-0321, Published: 2018;

74. Grigorie, A.C., Muntean, C., Vlase, G., Stefanescu, M. Synthesis and characterization of ZnAl<sub>2</sub>O<sub>4</sub> spinel from Zn(II) and Al(III) carboxylates, *JOURNAL OF THERMAL ANALYSIS AND CALORIMETRY*, Volume: 131, Issue: 1, Pages: 183-189, ISSN: 1388-6150, eISSN: 1588-2926, 2018;
75. Groza, B., Murvay, P.S. SECURITY SOLUTIONS FOR THE CONTROLLER AREA NETWORK Bringing Authentication to In-Vehicle Networks, *IEEE VEHICULAR TECHNOLOGY MAGAZINE*, Volume: 13, Issue: 1, Pages: 40-47, ISSN: 1556-6072, eISSN: 1556-6080, 2018;
76. Gurban, E.H., Andreescu, G.D. GREENHOUSE ENVIRONMENT MONITORING AND CONTROL: STATE OF THE ART AND CURRENT TRENDS, *ENVIRONMENTAL ENGINEERING AND MANAGEMENT JOURNAL*, Volume: 17, Issue: 2, Pages: 399-416, ISSN: 1582-9596, eISSN: 1843-3707, 2018;
77. Gurbina, M., Ciresan, A., Lascu, D., Lica, S., Pop-Calimanu, I.M. A New Exact Mathematical Approach for Studying Bifurcation in DCM Operated dc-dc Switching Converters, *ENERGIES*, Volume: 11, Issue: 3, Article Number: 663, ISSN: 1996-1073, 2018;
78. Hasmatuchi, V., Bosioc, A.I., Luisier, S., Munch-Alligne, C. A Dynamic Approach for Faster Performance Measurements on Hydraulic Turbomachinery Model Testing, *APPLIED SCIENCES-BASEL*, Volume: 8, Issue: 9, Article Number: 1426, ISSN: 2076-3417, 2018;
79. Holotescu, V., Vasiiu, R., Andone, D. A Critical Analysis of Mobile Applications for Learning. Study Case: Virtual Campus App, *BRAIN-BROAD RESEARCH IN ARTIFICIAL INTELLIGENCE AND NEUROSCIENCE*, Volume: 9, Special Issue: SI, Pages: 110-117, ISSN: 2067-3957, 2018;
80. Horvath, E., Pozna, C., Precup, R.E. Robot Coverage Path Planning Based on Iterative Structured Orientation, *ACTA POLYTECHNICA HUNGARICA*, Volume: 15, Issue: 2, Pages: 231-249, ISSN: 1785-8860, 2018;
81. Hutiu, G., Duma, V.F., Demian, D., Bradu, A., Podoleanu, A.G. Assessment of Ductile, Brittle, and Fatigue Fractures of Metals Using Optical Coherence Tomography, *METALS*, Volume: 8, Issue: 2, Article Number: 117, ISSN: 2075-4701, 2018;
82. Ianos, R. Key-role of the recipe formulation in the solution combustion synthesis of monocalcium aluminate, CaAl<sub>2</sub>O<sub>4</sub>, *CERAMICS INTERNATIONAL*, Volume: 44, Issue: 17, Pages: 21908-21913, ISSN: 0272-8842, eISSN: 1873-3956, 2018;
83. Ianos, R., Lazau, R., Babuta, R., Muntean, E., Moaca, E.A., Pacurariu, C. Solution combustion synthesis: a straightforward route for the preparation of chromium-doped lanthanum aluminate, LaAl<sub>1-x</sub>Cr<sub>x</sub>O<sub>3</sub>, pink red pigments, *DYES AND PIGMENTS*, Volume: 155, Pages: 218-224, ISSN: 0143-7208, eISSN: 1873-3743, 2018;
84. Ianos, R., Moaca, E.A., Caprarua, A., Lazau, R., Pacurariu, C. Maghemite, gamma-Fe<sub>2</sub>O<sub>3</sub>, nanoparticles preparation via carbon-templated solution combustion synthesis, *CERAMICS INTERNATIONAL*, Volume: 44, Issue: 12, Pages: 14090-14094, ISSN: 0272-8842, eISSN: 1873-3956, 2018;
85. Ianos, R., Muntean, E., Lazau, R., Babuta, R., Moaca, E.A., Pacurariu, C., Dabici, A., Hulka, I. One-step synthesis of near-infrared reflective brown pigments based on iron-doped lanthanum aluminate, LaAl<sub>1-x</sub>Fe<sub>x</sub>O<sub>3</sub>, *DYES AND PIGMENTS*, Volume: 152, Pages: 105-111, ISSN: 0143-7208, eISSN: 1873-3743, 2018;
86. Ianos, R., Pacurariu, C., Muntean, S.G., Muntean, E., Nistor, M.A., Niznansky, D. Combustion synthesis of iron oxide/carbon nanocomposites, efficient adsorbents for anionic and cationic dyes removal from wastewaters, *JOURNAL OF ALLOYS AND COMPOUNDS*, Volume: 741, Pages: 1235-1246, ISSN: 0925-8388, eISSN: 1873-4669, 2018;
87. Ilios, M., Bogatu, C., Lazau, C., Manea, F., Pode, R. Pharmaceutically Active Compounds Degradation Using Doped TiO<sub>2</sub> Functionalized Zeolite Photocatalyst, *REVISTA DE CHIMIE*, Volume: 69, Issue: 1, Pages: 34-37, ISSN: 0034-7752, 2018;
88. Ionel, I., Makra, L., Csepe, Z., Tusnady, G., Cercelaru, C., Ungureanu, C.I. ASSESSMENT OF RELATIONSHIP BETWEEN METEOROLOGICAL ELEMENTS AND AIR POLLUTANTS LOAD IN AN URBAN ENVIRONMENT, *JOURNAL OF ENVIRONMENTAL PROTECTION AND ECOLOGY*, Volume: 19, Issue: 4, Pages: 1462-1471, ISSN: 1311-5065, 2018;
89. Ionel, I., Vasilescu, M.D., Balogh, R.M., Bisorca, D., Makra, L., Ionel, R. CAREER DEVELOPMENT OF AN ENGINEERING STUDENT THROUGH COUNSELLING AND INTERNSHIP, *JOURNAL OF ENVIRONMENTAL PROTECTION AND ECOLOGY*, Volume: 19, Issue: 1, Pages: 357-366, ISSN: 1311-5065, 2018;
90. Jacimovic, B., Genic, S., Lelea, D. Calculation of the Heat Transfer Coefficient for Laminar Flow in Pipes in Practical Engineering Applications, *HEAT TRANSFER ENGINEERING*, Volume: 39, Issue: 20, Pages: 1794-1800, ISSN: 0145-7632, eISSN: 1521-0537, 2018;
91. Jumanca, D., Maticescu, A., Galuscan, A., Rusu, L.C., Muntean, C. Comparative Study of Acid Etching on Dental Enamel, *REVISTA DE CHIMIE*, Volume: 69, Issue: 10, Pages: 2913-2915, ISSN: 0034-7752, 2018;

92. Kazamer, N., Kossman, S., Baranyi, I., Chicot, D., Serban, V.A., Rajnai, Z., Voda, M. Influence of TiB<sub>2</sub> addition on the mechanical and tribological properties of NiCrBSi deposited by flame spraying, *MATERIAUX & TECHNIQUES*, Volume: 106, Issue: 2, Article Number: 202, ISSN: 0032-6895, eISSN: 1778-3771, 2018;
93. Khoa L., Declercq, D., Ghaffari, F., Kessal, L., Boncalo, O., Savin, V. Variable-Node-Shift Based Architecture for Probabilistic Gradient Descent Bit Flipping on QC-LDPC Codes, *IEEE TRANSACTIONS ON CIRCUITS AND SYSTEMS I-REGULAR PAPERS*, Volume: 65, Issue: 7, Pages: 2183-2195, ISSN: 1549-8328, eISSN: 1558-0806, 2018;
94. Kovacic, J., Marsavina, L., Linul, E. Poisson's Ratio of Closed-Cell Aluminium Foams, *MATERIALS*, Volume: 11, Issue: 10, Article Number: 1904, PubMed ID: 30301257, ISSN: 1996-1944, 2018;
95. Lazar, G.I., Constantin, A.T., Ghitescu, M.A., Nicoara, S.V. Numerical Modelling of a Town Water Distribution Network Optimum location of quality sensors, *REVISTA DE CHIMIE*, Volume: 69, Issue: 2, Pages: 358-364, ISSN: 0034-7752, 2018;
96. Lazar, I., Bordeasu, I., Circiumaru, A., Mitelea, I., Bocii, L.S. Behavior of Polymer Thin Films Deposited on Bronze Surfaces at Cavitation Erosion, *REVISTA DE CHIMIE*, Volume: 69, Issue: 10, Pages: 2921-2927, ISSN: 0034-7752, 2018;
97. Lazureanu, C. Integrable Deformations of Three-Dimensional Chaotic Systems, *INTERNATIONAL JOURNAL OF BIFURCATION AND CHAOS*, Volume: 28, Issue: 5, Article Number: 1850066, ISSN: 0218-1274, eISSN: 1793-6551, 2018;
98. Lazureanu, C., Petrisor, C. Stability and Energy-Casimir Mapping for Integrable Deformations of the Kermack-McKendrick System, *ADVANCES IN MATHEMATICAL PHYSICS*, Article Number: 5398768, ISSN: 1687-9120, eISSN: 1687-9139, 2018;
99. Li, X., Xu, W., Ye, C.Y., Boldea, I. Comparative Study of Transversal-Flux Permanent-Magnetic Linear Oscillatory Machines for Compressor, *IEEE TRANSACTIONS ON INDUSTRIAL ELECTRONICS*, Volume: 65, Issue: 9, Pages: 7437-7446, ISSN: 0278-0046, eISSN: 1557-9948, 2018;
100. Linul, E., Serban, D.A., Marsavina, L. Influence of Cell Topology on Mode I Fracture Toughness of Cellular Structures, *PHYSICAL MESOMECHANICS*, Volume: 21, Issue: 2, Pages: 178-186, ISSN: 1029-9599, eISSN: 1990-5424, 2018;
101. Linul, E., Valean, C., Linul, P.A. Compressive Behavior of Aluminum Microfibers Reinforced Semi-Rigid Polyurethane Foams, *POLYMERS*, Volume: 10, Issue: 12, Article Number: 1298, ISSN: 2073-4360, 2018;
102. Linul, E., Movahedi, N., Marsavina, L. The temperature and anisotropy effect on compressive behavior of cylindrical closed-cell aluminum-alloy foams, *JOURNAL OF ALLOYS AND COMPOUNDS*, Volume: 740, Pages: 1172-1179, ISSN: 0925-8388, eISSN: 1873-4669, 2018;
103. Linul, E., Movahedi, N., Marsavina, L. On the Lateral Compressive Behavior of Empty and Ex-Situ Aluminum Foam-Filled Tubes at High Temperature, *MATERIALS*, Volume: 11, Issue: 4, Article Number: 554, PubMed ID: 29617300, ISSN: 1996-1944, 2018;
104. Lovasz, E.C., Modler, K.H., Pop, C., Pop, F., Margineanu, D., Maniu, I. Type Synthesis and Analysis of Geared Linkages with Linear Actuation, *MECHANIKA*, Volume: 24, Issue: 1, Pages: 108-114, ISSN: 1392-1207, 2018;
105. Lupa, L., Cochechi, L., Pode, R., Hulka, I. Phenol adsorption using Aliquat 336 functionalized Zn-Al layered double hydroxide, *SEPARATION AND PURIFICATION TECHNOLOGY*, Volume: 196, Special Issue: SI, Pages: 82-95, ISSN: 1383-5866, eISSN: 1873-3794, 2018;
106. Lupa, L., Maranescu, B., Visa, A. Equilibrium and kinetic studies of chromium ions adsorption on Co (II)-based phosphonate metal organic frameworks, *SEPARATION SCIENCE AND TECHNOLOGY*, Volume: 53, Issue: 7, Pages: 1017-1026, ISSN: 0149-6395, eISSN: 1520-5754, 2018;
107. Lupa, L., Voda, R., Popa, A. Adsorption behavior of cesium and strontium onto chitosan impregnated with ionic liquid, *SEPARATION SCIENCE AND TECHNOLOGY*, Volume: 53, Issue: 7, Pages: 1107-1115, ISSN: 0149-6395, eISSN: 1520-5754, 2018;
108. Madescu, G., Berwanger, E., Biriescu, M., Mot, M. FAST ANALYSIS OF MMF HARMONICS CONTENT IN THREE-PHASE ELECTRICAL MACHINES, *PROCEEDINGS OF THE ROMANIAN ACADEMY SERIES A-MATHEMATICS PHYSICS TECHNICAL SCIENCES INFORMATION SCIENCE*, Volume: 19, Issue: 2, Pages: 369-376, ISSN: 1454-9069, 2018;
109. Maranescu, B., Lupa, L., Mihali, M.T.L., Plesu, N., Maranescu, V., Visa, A. The corrosion inhibitor behavior of iron in saline solution by the action of magnesium carboxyphosphonate, *PURE AND APPLIED CHEMISTRY*, Volume: 90, Issue: 11, Pages: 1713-1722, ISSN: 0033-4545, eISSN: 1365-3075, 2018;
110. Maranescu, B., Lupa, L., Visa, A. Heavy metal removal from waste waters by phosphonate metal organic frameworks, *PURE AND APPLIED CHEMISTRY*, Volume: 90, Issue: 1, Pages: 35-47, ISSN: 0033-4545, eISSN: 1365-3075, 2018;



111. Maranescu, B., Popa, A., Lupa, L., Maranescu, V., Visa, A. Use of chitosan complex with aminophosphonic groups and cobalt for the removal of Sr<sup>2+</sup> ions, *SEPARATION SCIENCE AND TECHNOLOGY*, Volume: 53, Issue: 7, Pages: 1058-1064, ISSN: 0149-6395, eISSN: 1520-5754, 2018;
112. Marc, S., Kirovski, D., Mircu, C., Hutu, I., Otava, G., Paul, C., Boldura, O.M., Tulcan, C. Serum Protein Electrophoretic Pattern in Neonatal Calves Treated with Clinoptilolite, *MOLECULES*, Volume: 23, Issue: 6, Article Number: 1278, PubMed ID: 29861463, ISSN: 1420-3049, 2018;
113. Marginean, I., Dinu, F., Dubina, D. Simulation of the dynamic response of steel moment frames following sudden column loss. Experimental calibration of the numerical model and application, *STEEL CONSTRUCTION-DESIGN AND RESEARCH*, Volume: 11, Issue: 1, Pages: 57-64, ISSN: 1867-0520, eISSN: 1867-0539, 2018;
114. Marinca, B., Marinca, V. APPROXIMATE ANALYTICAL SOLUTIONS FOR THIN FILM FLOW OF A FOURTH GRADE FLUID DOWN A VERTICAL CYLINDER, *PROCEEDINGS OF THE ROMANIAN ACADEMY SERIES A-MATHEMATICS PHYSICS TECHNICAL SCIENCES INFORMATION SCIENCE*, Volume: 19, Issue: 1, Pages: 69-76, ISSN: 1454-9069, 2018;
115. Marinca, B., Marinca, V. Some exact solutions for MHD flow and heat transfer to modified second grade fluid with variable thermal conductivity in the presence of thermal radiation and heat generation/absorption, *COMPUTERS & MATHEMATICS WITH APPLICATIONS*, Volume: 76, Issue: 6, Pages: 1515-1524, ISSN: 0898-1221, eISSN: 1873-7668, 2018;
116. Marinca, V., Marinca, B. OPTIMAL AUXILIARY FUNCTIONS METHOD FOR NONLINEAR THIN FILM FLOW OF A THIRD GRADE FLUID ON A MOVING BELT, *PROCEEDINGS OF THE ROMANIAN ACADEMY SERIES A-MATHEMATICS PHYSICS TECHNICAL SCIENCES INFORMATION SCIENCE*, Volume: 19, Issue: 4, Pages: 575-580, ISSN: 1454-9069, 2018;
117. Marinca, V., Ene, R.D., Marinca, V.B. Optimal Auxiliary Functions Method for viscous flow due to a stretching surface with partial slip, *OPEN ENGINEERING*, Volume: 8, Issue: 1, Pages: 261-274, ISSN: 2391-5439, 2018;
118. Maris, S., Maris, S.A., Dungan, L., Slavici, T. Re-shaping Education: Role of Internet Resources in Increasing the Efficiency of the Educational Process, *BRAIN-BROAD RESEARCH IN ARTIFICIAL INTELLIGENCE AND NEUROSCIENCE*, Volume: 9, Issue: 1, Pages: 132-137, ISSN: 2067-3957, 2018;
119. Masu, S., Cojocariu, L., Grecu, E., Morariu, F., Bordean, D.M., Horablaga, M. Nita, L., Nita, S. Lolium Perenne - A Phytoremediation Option in Case of Total Petroleum Hydrocarbons Polluted Soils, *REVISTA DE CHIMIE*, Volume: 69, Issue: 5, Pages: 1110-1114, ISSN: 0034-7752, 2018;
120. Matica, L.M., Gyorodi, C., Silaghi, H., Silaghi, A. Mixed Profile Method of Speed and Location for Robotic Arms Motion used for Precise Positioning, *INTERNATIONAL JOURNAL OF ADVANCED COMPUTER SCIENCE AND APPLICATIONS*, Volume: 9, Issue: 5, Pages: 32-36, ISSN: 2158-107X, eISSN: 2156-5570, 2018;
121. Miclaus, S., Iftode, C., Miclaus, A. Would the Human Brain Be Able to Erect Specific Effects due to the Magnetic Field Component of an UHF Field via Magnetite Nanoparticles?, *PROGRESS IN ELECTROMAGNETICS RESEARCH M*, Volume: 69, Pages: 23-36, ISSN: 1937-8726, eISSN: 1098-8963, 2018;
122. Micu, L.M., Lazar, I., Circiumaru, A., Bordeasu, I., Pirvulescu, L.D., Hluscu, M. New Results Regarding Cavitation Behavior of Polymers Modified with Anorganic Substances Coated on Bronze Surfaces, *MATERIALE PLASTICE*, Volume: 55, Issue: 3, Pages: 460-463, ISSN: 0025-5289, 2018;
123. Mihali, S.G., Canjau, S., Cernescu, A., Bortun, C.M., Wang, H.L., Bratu, E. Effects of a Short Drilling Implant Protocol on Osteotomy Site Temperature and Drill Torque, *IMPLANT DENTISTRY*, Volume: 27, Issue: 1, Pages: 63-68, PubMed ID: 29200004, ISSN: 1056-6163, 2018;
124. Mitelea, I., Bena, T., Bordeasu, I., Craciunescu, C.M. Relationships Between Microstructure, Roughness Parameters and Ultrasonic Cavitation Erosion Behaviour of Nodular Cast Iron, *EN-GJS-400-15*, *REVISTA DE CHIMIE*, Volume: 69, Issue: 3, Pages: 612-617, ISSN: 0034-7752, 2018;
125. Mitelea, I., Ghera, C., Bordeasu, I., Craciunescu, C. Assessment of Cavitation Erosion of Gas-Nitrided Cr-Ni-Mo Steels, *JOURNAL OF TRIBOLOGY-TRANSACTIONS OF THE ASME*, Volume: 140, Issue: 6, Article Number: 061601, ISSN: 0742-4787, eISSN: 1528-8897, 2018;
126. Moisa, M.E., Poppe, L., Gal, C.A., Bencze, L.C., Irimie, F.D., Paizs, C., Peter, F., Tosa, M.I. Click reaction- aided enzymatic kinetic resolution of secondary alcohols, *REACTION CHEMISTRY & ENGINEERING*, Volume: 3, Issue: 5, Pages: 790-798, ISSN: 2058-9883, 2018;
127. Mosoarca, G., Vancea, C., Popa, S., Boran, S. Adsorption, Bioaccumulation and Kinetics Parameters of the Phytoremediation of Cobalt from Wastewater Using *Elodea Canadensis*, *BULLETIN OF ENVIRONMENTAL CONTAMINATION AND TOXICOLOGY*, Volume: 100, Issue: 5, Pages: 733-739, PubMed ID: 29557493, ISSN: 0007-4861, eISSN: 1432-0800, 2018;

128. Mosoarca, M., Keller, A.I. A complex assessment methodology and procedure for historic roof structures, *INTERNATIONAL JOURNAL OF ARCHITECTURAL HERITAGE*, Volume: 12, Issue: 4, Special Issue: SI, Pages: 578-598, ISSN: 1558-3058, eISSN: 1558-3066, 2018;
129. Movahedi, N., Linul, E. Mechanical properties of Light Expanded Clay Aggregated (LECA) filled tubes, *MATERIALS LETTERS*, Volume: 217, Pages: 194-197, ISSN: 0167-577X, eISSN: 1873-4979, 2018;
130. Movahedi, N., Linul, E., Marsavina, L. The Temperature Effect on the Compressive Behavior of Closed-Cell Aluminum-Alloy Foams, *JOURNAL OF MATERIALS ENGINEERING AND PERFORMANCE*, Volume: 27, Issue: 1, Pages: 99-108, ISSN: 1059-9495, eISSN: 1544-1024, 2018;
131. Muntean, E., Stoia, M., Pacurariu, C. Facile synthesis, characterization and magnetic properties of manganese ferrite/carbon composites, *THERMOCHIMICA ACTA*, Volume: 667, Pages: 122-131, ISSN: 0040-6031, eISSN: 1872-762X, 2018;
132. Muntean, I., Titei, V., Gudima, A., Armas, A., Gadibadi, M. BIOMASS QUALITY OF SOME Poaceae SPECIES AND POSSIBLE USE FOR RENEWABLE ENERGY PRODUCTION IN MOLDOVA, *SCIENTIFIC PAPERS-SERIES A-AGRONOMY*, Volume: 61, Pages: 497-502, ISSN: 2285-5785, eISSN: 2285-5807, 2018;
133. Muntean, S.G., Nistor, M.A., Muntean, E., Todea, A., Ianos, R., Pacurariu, C. Removal of Colored Organic Pollutants from Wastewaters by Magnetite/Carbon Nanocomposites: Single and Binary Systems, *JOURNAL OF CHEMISTRY*, Article Number: 6249821, ISSN: 2090-9063, eISSN: 2090-9071, 2018;
134. Murariu, A.C., Cernescu, A.V., Perianu, I.A. The effect of saline environment on the fatigue behaviour of HVOF-sprayed WC-CrC-Ni coatings, *SURFACE ENGINEERING*, Volume: 34, Issue: 10, Pages: 755-761, ISSN: 0267-0844, eISSN: 1743-2944, 2018;
135. Murvay, P.S., Groza, B. Security Shortcomings and Countermeasures for the SAE J1939 Commercial Vehicle Bus Protocol, *IEEE TRANSACTIONS ON VEHICULAR TECHNOLOGY*, Volume: 67, Issue: 5, Pages: 4325-4339, ISSN: 0018-9545, eISSN: 1939-9359, 2018;
136. Nagib, R., Suzhanek, C., Moldoveanu, B., Negrutiu, M.L., Duma, V.F., Sinescu, C., Brad, S. Dimensional Study of Impacted Maxillary Canine Replicas 3D Printed Using Two Types of Resin Materials, *MATERIALE PLASTICE*, Volume: 55, Issue: 2, Pages: 190-191, ISSN: 0025-5289, 2018;
137. Nani, V.M. A New Algorithm for Predictive Metrological Verification of Measuring Apparatus, *INTERNATIONAL JOURNAL OF PRECISION ENGINEERING AND MANUFACTURING*, Volume: 19, Issue: 2, Pages: 167-172, ISSN: 2234-7593, eISSN: 2005-4602, 2018;
138. Negrea, A., Gabor, A., Davidescu, C.M., Ciopec, M., Negrea, P., Duteanu, N., Barbulescu, A. Rare Earth Elements Removal from Water Using Natural Polymers, *SCIENTIFIC REPORTS*, Volume: 8, Article Number: 316, PubMed ID: 29321487, ISSN: 2045-2322, 2018;
139. Negru, R., Serban, D.A., Pop, C., Marsavina, L. Notch effect assessment in a PUR material using a ring shaped specimen, *THEORETICAL AND APPLIED FRACTURE MECHANICS*, Volume: 97, Pages: 500-506, ISSN: 0167-8442, eISSN: 1872-7638, 2018;
140. Nelson, J.D.B., Gibberd, A.J., Naformita, C., Kingsbury, N. The locally stationary dual-tree complex wavelet model, *STATISTICS AND COMPUTING*, Volume: 28, Issue: 6, Pages: 1139-1154, ISSN: 0960-3174, eISSN: 1573-1375, 2018;
141. Nenu, P.F., Dungan, L.I., Cioabla, A.E., Rusu, G., Bandur, G.N., Dumitrel, A.G., Pode, V. BIOMASS ANALYSIS FOR COMBUSTION APPLICATIONS - CASE STUDY SCENARIOS, *STUDIA UNIVERSITATIS BABES-BOLYAI CHEMIA*, Volume: 63, Issue: 3, Pages: 7-20, ISSN: 1224-7154, 2018;
142. Nicoara, M., Buzdugan, D., Locovei, C., Bena, T., Stoica, M. About thermostability of biocompatible Ti-Zr-Ag-Pd-Sn amorphous alloys, *JOURNAL OF THERMAL ANALYSIS AND CALORIMETRY*, Volume: 133, Issue: 1, Pages: 189-197, ISSN: 1388-6150, eISSN: 1588-2926, 2018;
143. Nicola (Crisan), R., Costisor, O., Ianasi, C., Lazau, R., Sacarescu, L., Niznansky, D., Ercuta, A., Putz, A.M., Savii, C. FRACTAL SURFACE MAGHEMITE NANOPARTICLES PREPARED BY CO-PRECIPITATION: THE INFLUENCE OF IRON CONCENTRATION AND BASE NATURE, *STUDIA UNIVERSITATIS BABES-BOLYAI CHEMIA*, Volume: 63, Issue: 4, Pages: 15-29, ISSN: 1224-7154, 2018;
144. Nicorescu, V., Masu, S., Andres, L., Pascu, L.F., Vlaicu, I., Bozan, C., Hollerbach, W., Trava, I.D. Strategy for Ecologically Closure of Ash and Slag Deposits Using Energetic Crops, *REVISTA DE CHIMIE*, Volume: 69, Issue: 1, Pages: 45-49, ISSN: 0034-7752, 2018;
145. Niculescu, M., Pascariu, M.C., Muntean, C., Sasca, V., Lupa, L., Milea, M.S., Birzescu, M. Thermal and spectroscopic analysis of Co(II)-Fe(III) polyglyoxylate obtained through the reaction of ethylene glycol with metal nitrates, *JOURNAL OF THERMAL ANALYSIS AND CALORIMETRY*, Volume: 131, Issue: 1, Pages: 127-136, ISSN: 1388-6150, eISSN: 1588-2926, 2018;
146. Nita, L., Tarau, D., Rogobete, G., Nita, S., Bertici, R., Sas, I.T., Sas, I., Dicu, D. The Role of Ecopedological Parameters in Management Sustainability of Banat Lands, *REVISTA DE CHIMIE*, Volume: 69, Issue: 3, Pages: 688-692, ISSN: 0034-7752, 2018;

147. Niyonzima, S., Pop, N., Iacob, F., Larson, A., Orel, A.E., Mezej, J.Z., Chakrabarti, K., Laporta, V., Hassouni, K., Benredjem, D., Bultel, A., Tennyson, J., Reiter, D., Schneider, I.F. Low-energy collisions between electrons and BeD<sup>+</sup>, *PLASMA SOURCES SCIENCE & TECHNOLOGY*, Volume: 27, Issue: 2, Article Number: 025015, ISSN: 0963-0252, eISSN: 1361-6595, 2018;
148. Obrad, C., Gherhes, V. A Human Resources Perspective on Responsible Corporate Behavior. Case Study: The Multinational Companies in Western Romania, *SUSTAINABILITY*, Volume: 10, Issue: 3, Article Number: 726, ISSN: 2071-1050, 2018;
149. Oncioiu, I., Grecu, E., Masu, S., Morariu, F., Popa, M. The effect of fly ash on sunflower growth and human health, *ENVIRONMENTAL SCIENCE AND POLLUTION RESEARCH*, Volume: 25, Issue: 35, Special Issue: SI, Pages: 35548-35554, PubMed ID: 30350152, ISSN: 0944-1344, eISSN: 1614-7499, 2018;
150. Orha, C., Lazau, C., Pode, R., Manea, F. SIMULTANEOUS REMOVAL OF HUMIC ACID AND ARSENIC(III) FROM DRINKING WATER USING TiO<sub>2</sub>-POWDERED ACTIVATED CARBON, *JOURNAL OF ENVIRONMENTAL PROTECTION AND ECOLOGY*, Volume: 19, Issue: 1, Pages: 39-47, ISSN: 1311-5065, 2018;
151. Pana, A., Baloi, A., Molnar-Matei, F. From the Balancing Reactive Compensator to the Balancing Capacitive Compensator, *ENERGIES*, Volume: 11, Issue: 8, Article Number: 1979, ISSN: 1996-1073, 2018;
152. Pana, A., Baloi, A., Molnar-Matei, F. Iterative Method for Determining the Values of the Susceptances of a Balancing Capacitive Compensator, *ENERGIES*, Volume: 11, Issue: 10, Article Number: 2742, ISSN: 1996-1073, 2018;
153. Petrenko, V.I., Artykulnyi, O.P., Bulavin, L.A., Almasy, L., Garamus, V.M., Ivankov, O.I., Grigoryeva, N.A., Vekas, L., Kopcansky, P., Avdeev, M.V. On the impact of surfactant type on the structure of aqueous ferrofluids., *COLLOIDS AND SURFACES A-PHYSICO-CHEMICAL AND ENGINEERING ASPECTS*, Volume: 541, Pages: 222-226, ISSN: 0927-7757, eISSN: 1873-4359, 2018;
154. Pinca-Bretotean, C., Craciun, A.L., Josan, A., Ardelean, E. Experimental Study of Sintered Friction Material with Coconut Fiber for Brake Pads, *MATERIALE PLASTICE*, Volume: 55, Issue: 3, Pages: 389-392, ISSN: 0025-5289, 2018;
155. Pirjan, A., Carutasu, G., Petrosanu, D.M. Designing, Developing, and Implementing a Forecasting Method for the Produced and Consumed Electricity in the Case of Small Wind Farms Situated on Quite Complex Hilly Terrain, *ENERGIES*, Volume: 11, Issue: 10, Article Number: 2623, ISSN: 1996-1073, 2018;
156. Pislaru-Danescu, L., Morega, A.M., Dumitru, J.B., Morega, M., Popa, N.C., Stoian, F.D., Susan-Resiga, D., Holotescu, S., Popa, M. Miniature Planar Spiral Transformer With Hybrid, Ferrite, and Magnetic Nanofluid Core, *IEEE TRANSACTIONS ON MAGNETICS*, Volume: 54, Issue: 10, Article Number: 4600614, ISSN: 0018-9464, eISSN: 1941-0069, 2018;
157. Pop, A., Lung, S., Orha, C., Manea, F. Silver/graphene-modified Boron Doped Diamond Electrode for Selective Detection of Carbaryl and Paraquat from Water, *INTERNATIONAL JOURNAL OF ELECTROCHEMICAL SCIENCE*, Volume: 13, Issue: 3, Pages: 2651-2660, ISSN: 1452-3981, 2018;
158. Pop, C., Ene, R.D. Stability problems and numerical integration on the Lie group SO(3) x R-3 x R-3, *OPEN MATHEMATICS*, Volume: 16, Pages: 219-234, ISSN: 2391-5455, 2018;
159. Pop, C., Petrisor, C., Ene, R.D. Stabilization and Analytic Approximate Solutions of an Optimal Control Problem, *OPEN PHYSICS*, Volume: 16, Issue: 1, Pages: 476-487, ISSN: 2391-5471, 2018;
160. Pop, D.A., Malaescu, R., Marsavina, L., Hosszu, T., Rotar, R., Goguta, L., Duma, V.F., Negrutiu, M.L., Sinescu, C., Jivanescu, A. Fracture Resistance of CAD/CAM Versus Traditional Interim Fixed Dental Prostheses, *MATERIALE PLASTICE*, Volume: 55, Issue: 3, Pages: 361-363, ISSN: 0025-5289, 2018;
161. Popa, C.A. Global exponential stability of neutral-type octonion-valued neural networks with time-varying delays, *NEUROCOMPUTING*, Volume: 309, Pages: 117-133, ISSN: 0925-2312, eISSN: 1872-8286, 2018;
162. Popa, C.A. Global exponential stability of octonion-valued neural networks with leakage delay and mixed delays, *NEURAL NETWORKS*, Volume: 105, Pages: 277-293, PubMed ID: 29890384, ISSN: 0893-6080, eISSN: 1879-2782, 2018;
163. Popa, C.A. Learning Algorithms for Quaternion-Valued Neural Networks, *NEURAL PROCESSING LETTERS*, Volume: 47, Issue: 3, Special Issue: SI, Pages: 949-973, ISSN: 1370-4621, eISSN: 1573-773X, 2018;

164. Popa, C.A., Kaslik, E. Multistability and multiperiodicity in impulsive hybrid quaternion-valued neural networks with mixed delays, *NEURAL NETWORKS*, Volume: 99, Pages: 1-18, PubMed ID: 29306800, ISSN: 0893-6080, eISSN: 1879-2782, 2018;
165. Popa, D.M. CASE STUDY OF ENGINEERING RISK IN AUTOMOTIVE INDUSTRY, *MANAGEMENT SYSTEMS IN PRODUCTION ENGINEERING*, Volume: 26, Issue: 1, Pages: 27-30, ISSN: 2299-0461, eISSN: 2450-5781, 2018;
166. Popa, G.N., Dascalescu, L. Pulsed-high-voltage-supplied variable cross-section cylindrical electrostatic precipitators for fly-ash particles, *PARTICULATE SCIENCE AND TECHNOLOGY*, Volume: 36, Issue: 8, Pages: 1029-1036, ISSN: 0272-6351, eISSN: 1548-0046, 2018;
167. Popov, D. THERMAL STATES IN THE k-GENERALIZED HYPERGEOMETRIC COHERENT STATES REPRESENTATION, *PROCEEDINGS OF THE ROMANIAN ACADEMY SERIES A-MATHEMATICS PHYSICS TECHNICAL SCIENCES INFORMATION SCIENCE*, Volume: 19, Issue: 3, Pages: 431-438, ISSN: 1454-9069, 2018;
168. Porojan, L., Savencu C.E., Costea L.V., Dan M.L., Porojan, S.D. Corrosion Behavior of Ni-Cr Dental Casting Alloys, *INTERNATIONAL JOURNAL OF ELECTROCHEMICAL SCIENCE*, Volume: 13, Issue: 1, Pages: 410-423, ISSN: 1452-3981, 2018;
169. Pozna, C., Precup, R.E. An Approach to the Design of Nonlinear State-Space Control Systems, *STUDIES IN INFORMATICS AND CONTROL*, Volume: 27, Issue: 1, Pages: 5-14, ISSN: 1220-1766, 2018;
170. Precup, R.E., Teban, T.A., Albu, A., Szedlak-Stinean, A.I., Bojan-Drăgus, C.A. Experiments in Incremental Online Identification of Fuzzy Models of Finger Dynamics, *ROMANIAN JOURNAL OF INFORMATION SCIENCE AND TECHNOLOGY*, Volume: 21, Issue: 4, Special Issue: SI, Pages: 358-376, ISSN: 1453-8245, 2018;
171. Putz, M.V., Svera, P., Putz, A.M., Cataldo, F. Quantum particles on graphenic systems. Part 2. Bondons by absorption Raman spectra, *FULLERENES NANOTUBES AND CARBON NANOSTRUCTURES*, Volume: 26, Issue: 6, Pages: 330-341, ISSN: 1536-383X, eISSN: 1536-4046, 2018;
172. Racu, A.V., Baies, R., Popuri, S.R., Pascariu, M.C., Niculescu, M., Banica, R. Rapid combustion synthesis of Cu<sub>2</sub>Y<sub>2</sub>O<sub>5</sub> as a precursor for CuYO<sub>2</sub> delafossite, *MATERIALS TODAY COMMUNICATIONS*, Volume: 14, Pages: 233-239, ISSN: 2352-4928, 2018;
173. Racuciu, M., Iftode, C., Miclaus, S. Influence of 1 GHz radiation at low specific absorption rate of energy deposition on plant mitotic division process, *INTERNATIONAL JOURNAL OF ENVIRONMENTAL SCIENCE AND TECHNOLOGY*, Volume: 15, Issue: 6, Pages: 1233-1242, ISSN: 1735-1472, eISSN: 1735-2630, 2018;
174. Radac, M.B., Precup, R.E. Data-driven MIMO model-free reference tracking control with nonlinear state-feedback and fractional order controllers, *APPLIED SOFT COMPUTING*, Volume: 73, Pages: 992-1003, ISSN: 1568-4946, eISSN: 1872-9681, 2018;
175. Radac, M.B., Precup, R.E., Roman, R.C. Data-driven model reference control of MIMO vertical tank systems with model-free VRFT and Q-Learning, *ISA TRANSACTIONS*, Volume: 73, Pages: 227-238, PubMed ID: 29325777, ISSN: 0019-0578, eISSN: 1879-2022, 2018;
176. Radac, M.B., Precup, R.E. Data-driven model-free slip control of anti-lock braking systems using reinforcement Q-learning, *NEUROCOMPUTING*, Volume: 275, Pages: 317-329, ISSN: 0925-2312, eISSN: 1872-8286, 2018;
177. Radu, D., Sedmak, A., Bancila, R. Determining the crack acceptability in the welded joints of a wind loaded cylindrical steel shell structure, *ENGINEERING FAILURE ANALYSIS*, Volume: 91, Pages: 341-353, ISSN: 1350-6307, eISSN: 1873-1961, 2018;
178. Reisz, E., von Sonntag, C., Tekle-Rottering, A., Naumov, S., Schmidt, W., Schmidt, T.C. Reaction of 2-propanol with ozone in aqueous media, *WATER RESEARCH*, Volume: 128, Pages: 171-182, PubMed ID: 29102696, ISSN: 0043-1354, 2018;
179. Rennung, F., Paschek, D., Dufour, C.M., Draghici, A. MANAGING COMPLEXITY IN LARGE-SCALE BUSINESS PROJECTS. A THEORETICAL MODEL, *ACTA TECHNICA NAPOCENSIS SERIES-APPLIED MATHEMATICS MECHANICS AND ENGINEERING*, Volume: 61, Issue: 3, Special Issue: SI, Pages: 169-178, ISSN: 1221-5872, 2018;
180. Rennung, F., Paschek, D., Dufour, C.M., Draghici, A. MANAGING COMPLEXITY IN LARGE-SCALE BUSINESS PROJECTS. EXPERIMENTAL VALIDATION OF THE PROPOSED MODEL, *ACTA TECHNICA NAPOCENSIS SERIES-APPLIED MATHEMATICS MECHANICS AND ENGINEERING*, Volume: 61, Issue: 3, Special Issue: SI, Pages: 179-190, ISSN: 1221-5872, 2018;
181. Roman, M., Roman, D.L., Ostafe, V., Ciorsac, A., Isvoran, A. Computational Assessment of Pharmacokinetics and Biological Effects of Some Anabolic and Androgen Steroids, *PHARMACEUTICAL RESEARCH*, Volume: 35, Issue: 2, Article Number: UNSP 41, PubMed ID: 29404794, ISSN: 0724-8741, eISSN: 1573-904X, 2018;

182. Sarac, B., Gammer, C., Deng, L., Park, E., Yokoyama, Y., Stoica, M., Eckert, J. Elastostatic reversibility in thermally formed bulk metallic glasses: nanobeam diffraction fluctuation electron microscopy, *NANOSCALE*, Volume: 10, Issue: 3, Pages: 1081-1089, PubMed ID: 29271462, ISSN: 2040-3364, eISSN: 2040-3372, 2018;
183. Sarac, B., Ivanov, Y.P., Chuvin, A., Schoberl, T., Stoica, M., Zhang, Z.L., Eckert, J. Origin of large plasticity and multiscale effects in iron-based metallic glasses, *NATURE COMMUNICATIONS*, Volume: 9, Article Number: 1333, PubMed ID: 29626189, ISSN: 2041-1723, 2018;
184. Sarbu, I., Dorca, A. A comprehensive review of solar thermoelectric cooling systems, *INTERNATIONAL JOURNAL OF ENERGY RESEARCH*, Volume: 42, Issue: 2, Pages: 395-415, ISSN: 0363-907X, eISSN: 1099-114X, Published: 2018;
185. Sarbu, I., Iosif, A. A general analytical model for hydraulic computation of open channels with steady state uniform flow, *INTERNATIONAL JOURNAL OF ADVANCED AND APPLIED SCIENCES*, Volume: 5, Issue: 1, Pages: 1-7, ISSN: 2313-626X, eISSN: 2313-3724, 2018;
186. Sarbu, I., Sebarchievici, C. A Comprehensive Review of Thermal Energy Storage, *SUSTAINABILITY*, Volume: 10, Issue: 1, Article Number: 191, ISSN: 2071-1050, Published: 2018;
187. Sarbu, I., Tokar, A. Numerical modelling of high-temperature radiant panel heating system for an industrial hall, *INTERNATIONAL JOURNAL OF ADVANCED AND APPLIED SCIENCES*, Volume: 5, Issue: 5, Pages: 1-9, ISSN: 2313-626X, eISSN: 2313-3724, 2018;
188. Savencu, C.E., Costea, L.V., Dan, M.L., Porojan, L. Corrosion Behaviour of Co-Cr Dental Alloys Processed by Alternative CAD/CAM Technologies in Artificial Saliva Solutions, *INTERNATIONAL JOURNAL OF ELECTROCHEMICAL SCIENCE*, Volume: 13, Issue: 4, Pages: 3588-3600, ISSN: 1452-3981, 2018;
189. Sebarchievici, I., Lascu, A., Fagadar-Cosma, G., Palade, A., Fringu, I., Birdeanu, M., Taranu, B., Fagadar-Cosma, E. Optical and electrochemical-mediated detection of ascorbic acid using manganese porphyrin and its gold hybrids, *COMPTES RENDUS CHIMIE*, Volume: 21, Issue: 3-4, Pages: 327-338, ISSN: 1631-0748, eISSN: 1878-1543, 2018;
190. Seiman, D.D., Batalu, A., Seiman, C.D., Ciopec, M., Udrea, A.M., Motoc, M., Negrea, A., Avram, S. Pharmacological Effects of Natural Compounds Extracted from *Urtica dioica* Evaluated by in Silico and Experimental Methods, *REVISTA DE CHIMIE*, Volume: 69, Issue: 9, Pages: 2377-2381, ISSN: 0034-7752, 2018;
191. Sfirat, A., Gontean, A., Bularka, S. A New Method for MPPT Algorithm Implementation and Testing, Suitable for Photovoltaic Cells, *ADVANCES IN ELECTRICAL AND COMPUTER ENGINEERING*, Volume: 18, Issue: 3, Pages: 53-60, ISSN: 1582-7445, eISSN: 1844-7600, 2018;
192. Sinescu, C., Duma, V.F., Dodenciu, D., Stratul, S., Manole, M., Draganescu, G.E. Mechanical Properties of the Periodontal System and of Dental Constructs Deduced from the Free Response of the Tooth, *JOURNAL OF HEALTHCARE ENGINEERING*, Article Number: 4609264, PubMed ID: 30310558, ISSN: 2040-2295, eISSN: 2040-2309, 2018;
193. Spirache, M.A., Cretu, C., Cseh, L., Sasca, V., Badea, V., Tudose, R., Deveseleanu-Corici, L.N., Costisora, O., Szerb, E.I. IONIC SALTS OF NICOTINIC ACID AS MULTIFUNCTIONAL MATERIALS, *REVUE ROUMAINE DE CHIMIE*, Volume: 63, Issue: 5-6, Pages: 521-525, ISSN: 0035-3930, 2018;
194. Stan, A.T., Vaduva, A., Negrutiu, M.L., Sinescu, C., Szuhaneck, C., Rogobete, A., Muntean, D., Talpos, S., Duma, V.F., Idorasi, L., Hajaj, T., Rominu, M. Evaluation of Dental Composite Resin Interface and Adhesion Using Laser Scanning Confocal Microscopy, *MATERIALE PLASTICE*, Volume: 55, Issue: 4, Pages: 541-544, ISSN: 0025-5289, 2018;
195. Stanciu, E.M., Pascu, A., Roata, I.C., Croitoru, C., Tiorean, M., Rosca, J.M., Hulka, I. Solar radiation synthesis of functional carbonaceous materials using Al<sub>2</sub>O<sub>3</sub>/TiO<sub>2</sub>-Cu-HA doped catalyst, *APPLIED SURFACE SCIENCE*, Volume: 438, Pages: 33-40, ISSN: 0169-4332, eISSN: 1873-5584, 2018;
196. Stanciu, E.M., Pascu, A., Tiorean, M.H., Roata, I.C., Voiculescu, I., Hulka, I., Croitoru, C. Dissimilar Laser Welding of AISI 321 and AISI 1010, *TEHNICKI VJESNIK-TECHNICAL GAZETTE*, Volume: 25, Issue: 2, Pages: 344-349, ISSN: 1330-3651, eISSN: 1848-6339, 2018;
197. Stirb, I. Extending NUMA-BTLP Algorithm with Thread Mapping Based on a Communication Tree, *COMPUTERS*, Volume: 7, Issue: 4, Article Number: 66, ISSN: 2073-431X, Published: 2018.
198. Stoica, F., Chirita-Emandi, A., Andreescu, N., Stanciu, A., Zimbru, C.G., Puiu, M. Clinical relevance of retinal structure in children with laser-treated retinopathy of prematurity versus controls - using optical coherence tomography, *ACTA OPHTHALMOLOGICA*, Volume: 96, Issue: 2, Pages: e222-e228, PubMed ID: 28926210, ISSN: 1755-375X, eISSN: 1755-3768, 2018;

199. Susan-Resiga, D., Barvinschi, P. Correlation of rheological properties of ferrofluid-based magnetorheological fluids using the concentration-magnetization superposition, *JOURNAL OF RHEOLOGY*, Volume: 62, Issue: 3, Pages: 739-752, ISSN: 0148-6055, 2018;
200. Susan-Resiga, D., Vekas, L. FROM HIGH MAGNETIZATION FERROFLUIDS TO NANO-MICRO COMPOSITE MAGNETORHEOLOGICAL FLUIDS: PROPERTIES AND APPLICATIONS, *ROMANIAN REPORTS IN PHYSICS*, Volume: 70, Issue: 1, Article Number: 501, ISSN: 1221-1451, eISSN: 1841-8759, 2018;
201. Svera, P., Niznansky, D., Stefanut, M.N., Ursu, D., Sfirloaga, P., Dabici, A., Taranu, B.O., Putz, A.M., Serban, V.A. Studies on the hydrothermal synthesis of  $Cd_xZn_{1-x}S$  compounds, *PROCESSING AND APPLICATION OF CERAMICS*, Volume: 12, Issue: 3, Pages: 288-295, ISSN: 1820-6131, eISSN: 2406-1034, 2018;
202. Szabo, A., Bordeasu, I., Utu, I.D., Mitelea, I. In vitro Behaviour of Alumina-Hydroxiapatite Composites Coatings, *REVISTA DE CHIMIE*, Volume: 69, Issue: 6, Pages: 1416-1418, ISSN: 0034-7752, 2018;
203. Szabo, R., Gontean, A. Photovoltaic Cell and Module I-V Characteristic Approximation Using Bezier Curves, *APPLIED SCIENCES-BASEL*, Volume: 8, Issue: 5, Article Number: 655, ISSN: 2076-3417, 2018;
204. Szuhaneek, C., Golban, D.M., Negru, R., Negrutiu, M.L., Marsavina, L., Duma, V.F., Sinescu, C., Porojan, L. Flash-Free Orthodontic Adhesive System Compared with the Conventional Direct Bonding Method, *REVISTA DE CHIMIE*, Volume: 69, Issue: 11, Pages: 4093-4095, ISSN: 0034-7752, 2018;
205. Taherishargh, M., Linul, E., Broxtermann, S., Fiedler, T. The mechanical properties of expanded perlite-aluminium syntactic foam at elevated temperatures, *JOURNAL OF ALLOYS AND COMPOUNDS*, Volume: 737, Pages: 590-596, ISSN: 0925-8388, eISSN: 1873-4669, 2018;
206. Tigan, G., Analysis of Degenerate Fold-Hopf Bifurcation in a Three-Dimensional Differential System, *QUALITATIVE THEORY OF DYNAMICAL SYSTEMS*, Volume: 17, Issue: 2, Pages: 387-402, ISSN: 1575-5460, eISSN: 1662-3592, 2018;
207. Todea, A., Aparaschivei, D., Badea, V., Boeriu, C.G., Peter, F. Biocatalytic Route for the Synthesis of Oligoesters of Hydroxy-Fatty acids and E-Caprolactone, *BIOTECHNOLOGY JOURNAL*, Volume: 13, Issue: 6, Special Issue: SI, Article Number: 1700629, ISSN: 1860-6768, eISSN: 1860-7314, 2018;
208. Todea, A., Borza, P., Cimporescu, A., Paul, C., Peter, F. Continuous kinetic resolution of aliphatic and aromatic secondary alcohols by sol-gel entrapped lipases in packed bed bioreactors, *CATALYSIS TODAY*, Volume: 306, Pages: 223-232, ISSN: 0920-5861, eISSN: 1873-4308, 2018;
209. Todea, D.C.M., Luca, R.E., Balabuc, C.A., Miron, M.I., Locovei, C., Mocuta, D.E. Scanning electron microscopy evaluation of the root canal morphology after Er:YAG laser irradiation, *ROMANIAN JOURNAL OF MORPHOLOGY AND EMBRYOLOGY*, Volume: 59, Issue: 1, Pages: 269-275, PubMed ID: 29940637, ISSN: 1220-0522, 2018;
210. Topirceanu, A., Udrescu, M., Udrescu, L., Ardelean, C., Dan, R., Reisz, D., Mihaicuta, S. SAS score: Targeting high-specificity for efficient population-wide monitoring of obstructive sleep apnea, *PLOS ONE*, Volume: 13, Issue: 9, Article Number: e0202042, PubMed ID: 30183715, ISSN: 1932-6203, 2018;
211. Topirceanu, A., Udrescu, M., Marculescu, R. Weighted Betweenness Preferential Attachment: A New Mechanism Explaining Social Network Formation and Evolution, *SCIENTIFIC REPORTS*, Volume: 8, Article Number: 10871, PubMed ID: 30022079, ISSN: 2045-2322, 2018;
212. Topirceanu, A. Competition-Based Benchmarking of Influence Ranking Methods in Social Networks, *COMPLEXITY*, Article Number: 4562609, ISSN: 1076-2787, eISSN: 1099-0526, 2018;
213. Truong, N.L.T., Savin, V., Le, K., Declercq, D., Ghaffari, F., Boncalo, O. Analysis and Design of Cost-Effective, High-Throughput LDPC Decoders, *IEEE TRANSACTIONS ON VERY LARGE SCALE INTEGRATION (VLSI) SYSTEMS*, Volume: 26, Issue: 3, Pages: 508-521, ISSN: 1063-8210, eISSN: 1557-9999, 2018;
214. Tursie, C., Boata, R. MAPPING URBAN NETWORKS OF ROMANIAN CITIES IN COHESION PROJECTS 2007-2013: A STATISTICAL ANALYSIS, *ROMANIAN JOURNAL OF POLITICAL SCIENCE*, Volume: 18, Issue: 1, Pages: 43-78, ISSN: 1582-456X, 2018;
215. Tutelea, L.N., Popa, A., Staudt, T., de Espindola, A.A., Boldea, I. Optimal Design of 1 Phase Linear Oscillatory PM Motor Series for Small Compressor Like Drives: With FEM and Self-Starting Transients Validation, *ELECTRIC POWER COMPONENTS AND SYSTEMS*, Volume: 46, Issue: 1, Pages: 112-123, ISSN: 1532-5008, eISSN: 1532-5016, 2018;

216. Tutelea, L.N., Staudt, T., Popa, A.A., Hoffmann, W., Boldea, I. Line Start 1 Phase-Source Split Phase Capacitor Cage-PM Rotor-RelSyn Motor: Modeling, Performance, and Optimal Design With Experiments, IEEE TRANSACTIONS ON INDUSTRIAL ELECTRONICS, Volume: 65, Issue: 2, Pages: 1772-1780, ISSN: 0278-0046, eISSN: 1557-9948, 2018;
217. Ungureanu, V., Kotelko, M., Karmazyn, A., Dubina, D. Plastic mechanisms of thin-walled cold-formed steel members in eccentric compression, THIN-WALLED STRUCTURES, Volume: 128, Special Issue: SI, Pages: 184-192, ISSN: 0263-8231, eISSN: 1879-3223, 2018;
218. Ursu, D., Miclau, N., Miclau, M. n-Type Conductivity of Cu<sub>2</sub>O Thin Film Prepared in Basic Aqueous Solution Under Hydrothermal Conditions, ELECTRONIC MATERIALS LETTERS, Volume: 14, Issue: 4, Pages: 405-412, ISSN: 1738-8090, eISSN: 2093-6788, 2018;
219. Vancea, C., Jurca, R.M., Gheju, M., Mosoarca, G. ECO-FRIENDLY SOLUTION FOR WASTES RESULTED FROM THE REMOVAL OF Cr(VI) WITH Fe-0 IMMOBILIZATION IN GLASS BASED STONEWARE MATRIX, REVISTA ROMANA DE MATERIALE-ROMANIAN JOURNAL OF MATERIALS, Volume: 48, Issue: 3, Pages: 308-314, ISSN: 1583-3186, 2018;
220. Vasilescu, C., Latikka, M., Knudsen, K.D., Garamus, V.M., Socoliuc, V., Turcu, R., Tombacz, E., Susan-Resiga, D., Ras, R.H.A., Vekas, L. High concentration aqueous magnetic fluids: structure, colloidal stability, magnetic and flow properties, SOFT MATTER, Volume: 14, Issue: 32, Pages: 6648-6666, PubMed ID: 30035279, ISSN: 1744-683X, eISSN: 1744-6848, 2018;
221. Vasilescu, M.D., Fleser, T. Influence of Technological Parameters on the Dimension of GEAR Parts Generated with PLA Matherial by FDM 3D Printing, MATERIALE PLASTICE, Volume: 55, Issue: 2, Pages: 247-251, ISSN: 0025-5289, 2018;
222. Vasilescu, M.D., Fleser, T. Influence of Technological Parametrs on the Dimension of Threaded Parts Generated with PLA Matherial by FDM 3D Printing, MATERIALE PLASTICE, Volume: 55, Issue: 4, Pages: 718-722, ISSN: 0025-5289, 2018;
223. Vasilie, S., Manea, F., Baci, A., Pop, A. Dual use of boron-doped diamond electrode in antibiotics-containing water treatment and process control, PROCESS SAFETY AND ENVIRONMENTAL PROTECTION, Volume: 117, Pages: 446-453, ISSN: 0957-5820, eISSN: 1744-3598, 2018;
224. Vlascici, D., Plesu, N., Fagadar-Cosma, G., Lascu, A., Petric, M., Crisan, M., Belean, A., Fagadar-Cosma, E. Potentiometric Sensors for Iodide and Bromide Based on Pt(II)-Porphyrin, SENSORS, Volume: 18, Issue: 7, Article Number: 2297, PubMed ID: 30012951, ISSN: 1424-8220, 2018;
225. Vlazan, P., Stoia, M. Structural and magnetic properties of CoFe<sub>2</sub>O<sub>4</sub> nanopowders, prepared using a modified Pechini method, CERAMICS INTERNATIONAL, Volume: 44, Issue: 1, Pages: 530-536, ISSN: 0272-8842, eISSN: 1873-3956, 2018;
226. Wang, X.H., Inoue, A., Zhao, J.F., Kong, F.L., Zhu, S.L., Kaban, I., Stoica, M., Oswald, S., Fan, C., Shalaan, E., Al-Marzouki, F., Eckert, J., Yin, F.X., Li, Q. Liquid ejection temperature dependence of structure and glass transition behavior for rapidly solidified Zr-Al-M (M=Ni, Cu or Co) ternary glassy alloys, JOURNAL OF ALLOYS AND COMPOUNDS, Volume: 739, Pages: 1104-1114, ISSN: 0925-8388, eISSN: 1873-4669, 2018;
227. Yousefi-Talouki, A., Pescetto, P., Pellegrino, G., Boldea, I. Combined Active Flux and High-Frequency Injection Methods for Sensorless Direct-Flux Vector Control of Synchronous Reluctance Machines, IEEE TRANSACTIONS ON POWER ELECTRONICS, Volume: 33, Issue: 3, Pages: 2447-2457, ISSN: 0885-8993, eISSN: 1941-0107, 2018;
228. Zub, C.I., Stratan, A., Dogariu, A., Dubina, D. DEVELOPMENT OF A FINITE ELEMENT MODEL FOR A BUCKLING RESTRAINED BRACE, PROCEEDINGS OF THE ROMANIAN ACADEMY SERIES A-MATHEMATICS PHYSICS TECHNICAL SCIENCES INFORMATION SCIENCE, Volume: 19, Issue: 4, Pages: 581-588, ISSN: 1454-9069, 2018.

\* The data was obtained from Web of Science - Clarivate Analytics in 15 July 2019





# Papers in ISI Proceedings



1. Aipu, R., Silaghi, A., Buta, A., Nicolae, P.M., De Sabata, A. Interlaboratory Comparison of Radiated Emissions in Automotive EMC, 2018 INTERNATIONAL SYMPOSIUM ON ELECTROMAGNETIC COMPATIBILITY (EMC EUROPE), Book Series: IEEE International Symposium on Electromagnetic Compatibility, Pages: 994-997, International Symposium on Electromagnetic Compatibility (EMC EUROPE), AUG 27-30, 2018, Amsterdam, NETHERLANDS, ISSN: 2158-110X, ISBN: 978-1-4673-9698-1, Published: 2018;
2. Ambrus, R., Izvercian, M., Artene, A., Ivascu, L., Dogariu, E. SUSTAINABLE ECO DESIGN IN THE CONTEXT OF CIRCULAR ECONOMY IN ROMANIA, PERFORMANCE MANAGEMENT OR MANAGEMENT PERFORMANCE?, Book Series: Review of Management and Economic Engineering International Management Conference, Pages: 363-369, 6th Review of Management and Economic Engineering International Management Conference, SEP 20-22, 2018, Cluj Napoca, ROMANIA, ISSN: 2247-8639, Published: 2018;
3. Ambrus, R., Izvercian, M., Ivascu, L., Balan, M., Artene, A., Dogariu, E. THE INFLUENCE OF PRODUCT PLACEMENT IN BUYING DECISION, PERFORMANCE MANAGEMENT OR MANAGEMENT PERFORMANCE?, Book Series: Review of Management and Economic Engineering International Management Conference, Pages: 394-408, 6th Review of Management and Economic Engineering International Management Conference, SEP 20-22, 2018, Cluj Napoca, ROMANIA, ISSN: 2247-8639, Published: 2018;
4. Ancuti, C.O., Ancuti, C., Balta, H. Effective Local Backscattering Estimation for Underwater Image Enhancement, OCEANS 2018 MTS/IEEE CHARLESTON, Conference on OCEANS MTS/IEEE Charleston, OCT 22-25, 2018, Charleston, SC, ISBN: 978-1-5386-4814-8, Published: 2018;
5. Ancuti, C.O., Ancuti, C., De Vleeschouwer, C. EFFECTIVE LOCAL AIRLIGHT ESTIMATION FOR IMAGE DEHAZING, 2018 25TH IEEE INTERNATIONAL CONFERENCE ON IMAGE PROCESSING (ICIP), Book Series: IEEE International Conference on Image Processing ICIP, Pages: 2850-2854, 25th IEEE International Conference on Image Processing (ICIP), OCT 07-10, 2018, Athens, GREECE, ISSN: 1522-4880, ISBN: 978-1-4799-7061-2, Published: 2018;
6. Ancuti, C.O., Ancuti, C., Timofte, R., De Vleeschouwer, C. O-HAZE: a dehazing benchmark with real hazy and haze-free outdoor images, PROCEEDINGS 2018 IEEE/CVF CONFERENCE ON COMPUTER VISION AND PATTERN RECOGNITION WORKSHOPS (CVPRW), Book Series: IEEE Computer Society Conference on Computer Vision and Pattern Recognition Workshops, Pages: 867-875, IEEE/CVF Conference on Computer Vision and Pattern Recognition (CVPR), JUN 18-22, 2018, Salt Lake City, UT, ISSN: 2160-7508, ISBN: 978-1-5386-6100-0, Published: 2018;
7. Ancuti, C., Ancuti, C.O., Timofte, R., Van Gool, L., Zhang, L., Yang, M.H., Patel, V.M., Zhang, H., Sindagi, V.A., Zhao, R.H., Ma, X.P., Qin, Y., Jia, L.M., Friedel, K., Ki, S., Sim, H., Choi, J.S., Kim, S.Y., Seo, S., Kim, S., Kim, M., Mondal, R., Santra, S., Chanda, B., Liu, J.L., Mei, K.F., Li, J.C., Luyao, Fang, F.M., Jiang, A.W., Qu, X.C., Liu, T., Wang, P.F., Sun, B., Deng, J.F., Zhao, Y.H., Hong, M., Huang, J.Y., Chen, Y.Z., Chen, E.R., Yu, X.L., Wu, T.T., Genc, A., Engin, D., Ekenel, H.K., Liu, W.Z., Tong, T., Li, G., Gao, Q.Q., Li, Z., Tang, D.F., Chen, Y.L., Huo, Z.Y., Alvarez-Gila, A., Galdran, A., Bria, A., Vazquez-Corral, J., Bertalmo, M., Demir, H.S., Adil, O.F., Phung, H.X., Jin, X., Chen, J.L., Shan, C.W., Chen, Z.B. NTIRE 2018 Challenge on Image Dehazing: Methods and Results, PROCEEDINGS 2018 IEEE/CVF CONFERENCE ON COMPUTER VISION AND PATTERN RECOGNITION WORKSHOPS (CVPRW), Book Series: IEEE Computer Society Conference on Computer Vision and Pattern Recognition Workshops, Pages: 1004-1014, IEEE/CVF Conference on Computer Vision and Pattern Recognition (CVPR), JUN 18-22, 2018, Salt Lake City, UT, ISSN: 2160-7508, ISBN: 978-1-5386-6100-0, Published: 2018;
8. Andreica, T., Groza, B., Murvay, P.S. Applications of Pairing-Based Cryptography on Automotive-Grade Microcontrollers, COMPUTER SAFETY, RELIABILITY, AND SECURITY, SAFECOMP 2018, Book Series: Lecture Notes in Computer Science, Volume: 11094, Pages: 331-343, 37th International Conference on Computer Safety, Reliability, and Security (SAFECOMP), SEP 18-21, 2018, Vasteras, SWEDEN, ISSN: 0302-9743, eISSN: 1611-3349, ISBN: 978-3-319-99229-7; 978-3-319-99228-0, Published: 2018;
9. Anton, A. Romanian biometric word list for public key fingerprint validation, 2018 IEEE 12TH INTERNATIONAL SYMPOSIUM ON APPLIED COMPUTATIONAL INTELLIGENCE AND INFORMATICS (SACI), Pages: 143-148, 12th IEEE International Symposium on Applied Computational Intelligence and Informatics (SACI), MAY 17-19, 2018, Timisoara, ROMANIA, ISBN: 978-1-5386-4640-3, Published: 2018;
10. Ardelean, S.M., Udrescu, M. QC vertical bar pp >: A Behavioral Quantum Computing Simulation Library, 2018 IEEE 12TH INTERNATIONAL SYMPOSIUM ON APPLIED COMPUTATIONAL INTELLIGENCE AND INFORMATICS (SACI), Pages: 437-442, 12th IEEE International Symposium on Applied Computational Intelligence and Informatics (SACI), MAY 17-19, 2018, Timisoara, ROMANIA, ISBN: 978-1-5386-4640-3, Published: 2018;

11. Arvinti, B., Costache, M. Adaptive Thresholding Algorithm for Noisy Electrocardiograms using Reverse Biorthogonal Mother Wavelets, 2018 13TH INTERNATIONAL SYMPOSIUM ON ELECTRONICS AND TELECOMMUNICATIONS (ISETC), Book Series: International Symposium on Electronics and Telecommunications, Pages: 277-280, 13th International Symposium on Electronics and Telecommunications (ISETC), NOV 08-09, 2018, Timisoara, ROMANIA, ISSN: 2475-787X, ISBN: 978-1-5386-5925-0, Published: 2018;
12. Arvinti, B., Stolz, R., Costache, M. Wavelet Shrinkage of Magnetocardiograms Using the Median Absolute Deviation, 2018 13TH INTERNATIONAL SYMPOSIUM ON ELECTRONICS AND TELECOMMUNICATIONS (ISETC), Book Series: International Symposium on Electronics and Telecommunications, Pages: 281-284, 13th International Symposium on Electronics and Telecommunications (ISETC), NOV 08-09, 2018, Timisoara, ROMANIA, ISSN: 2475-787X, ISBN: 978-1-5386-5925-0, Published: 2018;
13. Avram, I.A., Porobic I., Papazian, P. An overview of intelligent surveillance systems development, 2018 13TH INTERNATIONAL SYMPOSIUM ON ELECTRONICS AND TELECOMMUNICATIONS (ISETC), Book Series: International Symposium on Electronics and Telecommunications, Pages: 38-43, 13th International Symposium on Electronics and Telecommunications (ISETC), NOV 08-09, 2018, Timisoara, ROMANIA, ISSN: 2475-787X, ISBN: 978-1-5386-5925-0, Published: 2018;
14. Baban, G., Iovanovici, A., Cosariu, C., Prodan, L. High Betweenness Nodes and Crowded Intersections: An Experimental Assessment by Means of Simulation, 2018 IEEE 12TH INTERNATIONAL SYMPOSIUM ON APPLIED COMPUTATIONAL INTELLIGENCE AND INFORMATICS (SACI), Pages: 339-344, 12th IEEE International Symposium on Applied Computational Intelligence and Informatics (SACI), MAY 17-19, 2018, Timisoara, ROMANIA, ISBN: 978-1-5386-4640-3, Published: 2018;
15. Bacria, V., Ghita, E., Herisanu, N. On Acoustic Comfort in Urban Transport on Rails, ACOUSTICS AND VIBRATION OF MECHANICAL STRUCTURES (AVMS-2017), Book Series: Springer Proceedings in Physics, Volume: 198, Pages: 83-90, 14th International Conference on Acoustics and Vibration of Mechanical Structures (AVMS), MAY 25-26, 2017, Timisoara, ROMANIA, ISSN: 0930-8989, eISSN: 1867-4941, ISBN: 978-3-319-69823-6; 978-3-319-69822-9, Published: 2018;
16. Badea, A., Prosteau, G., Vasar, C. Relieving Supply Chain Through Collaboration for Wind Turbine Assembly Based on AHP and DBR, SOFT COMPUTING APPLICATIONS, SOFA 2016, VOL 2, Book Series: Advances in Intelligent Systems and Computing, Volume: 634, Pages: 201-217, 7th International Workshop on Soft Computing Applications (SOFA), AUG 24-26, 2016, Arad, ROMANIA, ISSN: 2194-5357, eISSN: 2194-5365, ISBN: 978-3-319-62524-9, Published: 2018;
17. Balint, C., Budura, G. OFDM-Based Multi-Carrier Waveforms Performances in 5G, 2018 13TH INTERNATIONAL SYMPOSIUM ON ELECTRONICS AND TELECOMMUNICATIONS (ISETC), Book Series: International Symposium on Electronics and Telecommunications, Pages: 225-228, 13th International Symposium on Electronics and Telecommunications (ISETC), NOV 08-09, 2018, Timisoara, ROMANIA, ISSN: 2475-787X, ISBN: 978-1-5386-5925-0, Published: 2018;
18. Balint, C., De Sabata, A. Directional Measurement of HF Spectrum Occupancy, 2018 13TH INTERNATIONAL SYMPOSIUM ON ELECTRONICS AND TELECOMMUNICATIONS (ISETC), Book Series: International Symposium on Electronics and Telecommunications, Pages: 168-171, 13th International Symposium on Electronics and Telecommunications (ISETC), NOV 08-09, 2018, Timisoara, ROMANIA, ISSN: 2475-787X, ISBN: 978-1-5386-5925-0, Published: 2018;
19. Baniias, O. Dynamic programming optimization algorithm applied in test case selection, 2018 13TH INTERNATIONAL SYMPOSIUM ON ELECTRONICS AND TELECOMMUNICATIONS (ISETC), Book Series: International Symposium on Electronics and Telecommunications, Pages: 106-109, 13th International Symposium on Electronics and Telecommunications (ISETC), NOV 08-09, 2018, Timisoara, ROMANIA, ISSN: 2475-787X, ISBN: 978-1-5386-5925-0, Published: 2018;
20. Barb, G.R., Ottesteanu, M. 5G: An Overview on Challenges and Key Solutions, 2018 13TH INTERNATIONAL SYMPOSIUM ON ELECTRONICS AND TELECOMMUNICATIONS (ISETC), Book Series: International Symposium on Electronics and Telecommunications, Pages: 207-210, 13th International Symposium on Electronics and Telecommunications (ISETC), NOV 08-09, 2018, Timisoara, ROMANIA, ISSN: 2475-787X, ISBN: 978-1-5386-5925-0, Published: 2018;
21. Barbulescu, C., Kilyeni, S., Deacu, A., Simo, A., Craciun, M. Power Consumption Forecast Quality Assessment, 2018 7TH INTERNATIONAL CONFERENCE ON COMPUTERS COMMUNICATIONS AND CONTROL (ICCCC 2018), Pages: 103-110, 7th International Conference on Computers Communications and Control (ICCCC), MAY 08-12, 2018, Oradea, ROMANIA, ISBN: 978-1-5386-1934-6, Published: 2018;

22. Barina, G., Udrescu, M., Topirceanu, A., Vladutiu, M. Simulating payoff distribution in networks of economic agents, 2018 IEEE/ACM INTERNATIONAL CONFERENCE ON ADVANCES IN SOCIAL NETWORKS ANALYSIS AND MINING (ASONAM), Pages: 467-470, IEEE/ACM International Conference on Advances in Social Networks Analysis and Mining (ASONAM), AUG 28-31, 2018, Barcelona, SPAIN, ISBN: 978-1-5386-6051-5, Published: 2018;
23. Beiu, R.M., Beiu, V., Duma, V.F. Ultra-small mechanical deformation sensor using a hybrid fiber optic-based triangular photonic crystal structure, OPTICAL MICRO- AND NANOMETROLOGY VII, Book Series: Proceedings of SPIE, Volume: 10678, Article Number: UNSP 106780Z, Conference on Optical Micro- and Nanometrology VII, APR 25-26, 2018, Strasbourg, FRANCE, ISSN: 0277-786X, eISSN: 1996-756X, ISBN: 978-1-5106-1883-1, Published: 2018;
24. Beiu, R.M., Beiu, V., Duma, V.F. Fundamentals and biomedical applications of photonic crystals: An overview, SEVENTH INTERNATIONAL CONFERENCE ON LASERS IN MEDICINE, Book Series: Proceedings of SPIE, Volume: 10831, Article Number: UNSP 108310R, 7th Romanian-Society-for-Laser-in-Dentistry (SRLS) International Conference on Lasers in Medicine / 1st Congress of Laser in Dentistry, JUL 13-15, 2017, Timisoara, ROMANIA, ISSN: 0277-786X, eISSN: 1996-756X, ISBN: 978-1-5106-2288-3, Published: 2018;
25. Belega, D., Petri, D., Dallet, D. Accuracy of Synchrophasor Estimation Returned by a Frequency-Domain Linear Least-Squares Algorithm, 2018 13TH INTERNATIONAL SYMPOSIUM ON ELECTRONICS AND TELECOMMUNICATIONS (ISETC), Book Series: International Symposium on Electronics and Telecommunications, Pages: 267-270, 13th International Symposium on Electronics and Telecommunications (ISETC), NOV 08-09, 2018, Timisoara, ROMANIA, ISSN: 2475-787X, ISBN: 978-1-5386-5925-0, Published: 2018;
26. Belega, D. Determination of the Contribution of the Spectral Image Component on the Amplitude Estimator Provided by the Three-Point Interpolated DFT Algorithm, 2018 12TH INTERNATIONAL CONFERENCE ON COMMUNICATIONS (COMM), Book Series: IEEE International Conference on Communications, Pages: 81-84, 12th IEEE International Conference on Communications (COMM), JUN 14-16, 2018, Bucharest, ROMANIA, ISSN: 1550-3607, ISBN: 978-1-5386-2350-3, Published: 2018;
27. Belega, D., Petri, D. Accuracy of the Synchrophasor Estimator Returned by the Interpolated DFT Algorithm Under Off-Nominal Frequency and Harmonic Conditions, 2018 IEEE 9TH INTERNATIONAL WORKSHOP ON APPLIED MEASUREMENTS FOR POWER SYSTEMS (AMPS), Book Series: IEEE International Workshop on Applied Measurements for Power Systems, Pages: 105-110, 9th IEEE International Workshop on Applied Measurements for Power Systems (AMPS), SEP 26-28, 2018, Bologna, ITALY, ISSN: 2473-1315, ISBN: 978-1-5386-5375-3, Published: 2018;
28. Berdich, A.M., Andreescu, G.D. Master-Slave Tracking System for Mobile Robots, 2018 IEEE 12TH INTERNATIONAL SYMPOSIUM ON APPLIED COMPUTATIONAL INTELLIGENCE AND INFORMATICS (SACI), Pages: 45-49, 12th IEEE International Symposium on Applied Computational Intelligence and Informatics (SACI), MAY 17-19, 2018, Timisoara, ROMANIA, ISBN: 978-1-5386-4640-3, Published: 2018;
29. Bernad, E., Moza, A., Bernad, I.S. Ultrasound Assessment of the Umbilical Cord Knot, PROCEEDINGS OF THE 6TH CONGRESS OF THE ULTRASOUND SOCIETY IN OBSTETRICS AND GYNECOLOGY / 34TH FETUS AS A PATIENT INTERNATIONAL CONGRESS, Pages: 46-50, 6th Congress of the Ultrasound-Society-in-Obstetrics-and-Gynecology, MAY 16-19, 2018, Bucharest, ROMANIA, ISBN: 978-88-85813-20-5, Published: 2018;
30. Bernad, I.S., Moza, A., Bernad, E. Umbilical Cord Sonographic and Numerical Investigation, PROCEEDINGS OF THE 6TH CONGRESS OF THE ULTRASOUND SOCIETY IN OBSTETRICS AND GYNECOLOGY / 34TH FETUS AS A PATIENT INTERNATIONAL CONGRESS, Pages: 349-352, 6th Congress of the Ultrasound-Society-in-Obstetrics-and-Gynecology, MAY 16-19, 2018, Bucharest, ROMANIA, ISBN: 978-88-85813-20-5, Published: 2018;
31. Bernad, I.S., Moza, A., Mitrache, D. Evaluation of the Umbilical Cord Insertion, PROCEEDINGS OF THE 6TH CONGRESS OF THE ULTRASOUND SOCIETY IN OBSTETRICS AND GYNECOLOGY / 34TH FETUS AS A PATIENT INTERNATIONAL CONGRESS, Pages: 316-320, 6th Congress of the Ultrasound-Society-in-Obstetrics-and-Gynecology, MAY 16-19, 2018, Bucharest, ROMANIA, ISBN: 978-88-85813-20-5, Published: 2018;
32. Blagoiev, M., Gruicin, I., Ionascu, M.E., Marcu, M. A Study on Correlation between Air Pollution and Traffic, 2018 26TH TELECOMMUNICATIONS FORUM (TELFOR), Pages: 791-794, 26th Telecommunications Forum (TELFOR), NOV 20-21, 2018, Belgrade, SERBIA, ISBN: 978-1-5386-7171-9, Published: 2018;
33. Boar, R., Iovanovici, A., Ciocarlie, H. Complex Networks with Applicability to the Structure and Dynamics of Stock Market Evolution, 2018 IEEE 12TH INTERNATIONAL SYMPOSIUM ON APPLIED COMPUTATIONAL INTELLIGENCE AND INFORMATICS (SACI), Pages: 443-447, 12th IEEE International Symposium on Applied Computational Intelligence and Informatics (SACI), MAY 17-19, 2018, Timisoara, ROMANIA, ISBN: 978-1-5386-4640-3, Published: 2018;

34. Bojan-Dragos, C.A., Szedlak-Stinean, A.I., Precup, R.E., Gurgui, L., Hedrea, E.L., Mituletu, I.C. Control Solutions for Vertical Three-Tank Systems, 2018 IEEE 12TH INTERNATIONAL SYMPOSIUM ON APPLIED COMPUTATIONAL INTELLIGENCE AND INFORMATICS (SACI), Pages: 593-598, 12th IEEE International Symposium on Applied Computational Intelligence and Informatics (SACI), MAY 17-19, 2018, Timisoara, ROMANIA, ISBN: 978-1-5386-4640-3, Published: 2018;
35. Bolintis, R., Bogdan, R., Crisan-Vida, M., Stoicu-Tivadar, L. PillHelper - an application for treatment administration, 2018 IEEE 12TH INTERNATIONAL SYMPOSIUM ON APPLIED COMPUTATIONAL INTELLIGENCE AND INFORMATICS (SACI), Pages: 527-531, 12th IEEE International Symposium on Applied Computational Intelligence and Informatics (SACI), MAY 17-19, 2018, Timisoara, ROMANIA, ISBN: 978-1-5386-4640-3, Published: 2018;
36. Borlea, I.D., Precup, R.E., Dragan, F., Borlea, A.B. Parallel Implementation of K-Means Algorithm Using MapReduce Approach, 2018 IEEE 12TH INTERNATIONAL SYMPOSIUM ON APPLIED COMPUTATIONAL INTELLIGENCE AND INFORMATICS (SACI), Pages: 75-80, 12th IEEE International Symposium on Applied Computational Intelligence and Informatics (SACI), MAY 17-19, 2018, Timisoara, ROMANIA, ISBN: 978-1-5386-4640-3, Published: 2018;
37. Bosioc, A.I., Muntean, S., Anton, L.E. Numerical Simulation of an Axial Rotor with Variable Speed in a Pump Impeller, INTERNATIONAL CONFERENCE OF NUMERICAL ANALYSIS AND APPLIED MATHEMATICS (ICNAAM 2017), Book Series: AIP Conference Proceedings, Volume: 1978, Article Number: UNSP 030017-1, International Conference of Numerical Analysis and Applied Mathematics (ICNAAM), SEP 25-30, 2017, Thessaloniki, GREECE, ISSN: 0094-243X, ISBN: 978-0-7354-1690-1, Published: 2018;
38. Bujanca, A.M., Haiducu, C.G., Lie, I. Stand for the functional testing automation of the electronic modules, 2018 13TH INTERNATIONAL SYMPOSIUM ON ELECTRONICS AND TELECOMMUNICATIONS (ISETC), Book Series: International Symposium on Electronics and Telecommunications, Pages: 44-47, 13th International Symposium on Electronics and Telecommunications (ISETC), NOV 08-09, 2018, Timisoara, ROMANIA, ISSN: 2475-787X, ISBN: 978-1-5386-5925-0, Published: 2018;
39. Bularka, S., Szabo, R., Ottesteanu, M., Babaita, M. Robotic Arm Control with Hand Movement Gestures, 2018 41ST INTERNATIONAL CONFERENCE ON TELECOMMUNICATIONS AND SIGNAL PROCESSING (TSP), Pages: 543-546, 41st International Conference on Telecommunications and Signal Processing (TSP), JUL 04-06, 2018, Athens, GREECE, ISBN: 978-1-5386-4695-3, Published: 2018;
40. Buta, P.A., Pirvu, C., Balan, C., Aipu, R., De Sabata, A. Stripline Measurements in Automotive EMC: A Case Study, 2018 13TH INTERNATIONAL SYMPOSIUM ON ELECTRONICS AND TELECOMMUNICATIONS (ISETC), Book Series: International Symposium on Electronics and Telecommunications, Pages: 172-175, 13th International Symposium on Electronics and Telecommunications (ISETC), NOV 08-09, 2018, Timisoara, ROMANIA, ISSN: 2475-787X, ISBN: 978-1-5386-5925-0, Published: 2018;
41. Buta, P.A., De Sabata, A., Iftode, C., Silaghi, A.M., Matekovits, L. Applications of a Frequency Selective Surface based on a Combination of a Jerusalem Cross and a Circular Ring, 2018 12TH INTERNATIONAL CONFERENCE ON COMMUNICATIONS (COMM), Book Series: IEEE International Conference on Communications, Pages: 239-242, 12th IEEE International Conference on Communications (COMM), JUN 14-16, 2018, Bucharest, ROMANIA, ISSN: 1550-3607, ISBN: 978-1-5386-2350-3, Published: 2018;
42. Caiman, D.V., Dragomir, T.L. Non Intrusive Load Monitoring: Analytic Expressions as Load Signature, 2018 IEEE 12TH INTERNATIONAL SYMPOSIUM ON APPLIED COMPUTATIONAL INTELLIGENCE AND INFORMATICS (SACI), Pages: 15-20, 12th IEEE International Symposium on Applied Computational Intelligence and Informatics (SACI), MAY 17-19, 2018, Timisoara, ROMANIA, ISBN: 978-1-5386-4640-3, Published: 2018;
43. Caiman, D.V., Dragomir, T.L. Two voltage-current load signature classes for residential consumers, 2018 22ND INTERNATIONAL CONFERENCE ON SYSTEM THEORY, CONTROL AND COMPUTING (ICSTCC), Book Series: International Conference on System Theory Control and Computing, Pages: 176-181, 22nd International Conference on System Theory, Control and Computing (ICSTCC), OCT 10-12, 2018, Sinaia, ROMANIA, ISSN: 2372-1618, ISBN: 978-1-5386-4444-7, Published: 2018;
44. Canjau, S., Todea, C., Sinescu, C., Pricop, M., Duma, V.F. Fluorescence Influence on Screening Decisions for Oral Cancer, SEVENTH INTERNATIONAL CONFERENCE ON LASERS IN MEDICINE, Book Series: Proceedings of SPIE, Volume: 10831, Article Number: UNSP 1083109, 7th Romanian-Society-for-Laser-in-Dentistry (SRLS) International Conference on Lasers in Medicine / 1st Congress of Laser in Dentistry, JUL 13-15, 2017, Timisoara, ROMANIA, ISSN: 0277-786X, eISSN: 1996-756X, ISBN: 978-1-5106-2288-3, Published: 2018;

45. Capota, E.A., Stangaciu, C.S., Micea, M.V., Cretu, V.I. P\_FENP: A Multiprocessor Real-Time Scheduling Algorithm, 2018 IEEE 12TH INTERNATIONAL SYMPOSIUM ON APPLIED COMPUTATIONAL INTELLIGENCE AND INFORMATICS (SACI), Pages: 509-514, 12th IEEE International Symposium on Applied Computational Intelligence and Informatics (SACI), MAY 17-19, 2018, Timisoara, ROMANIA, ISBN: 978-1-5386-4640-3, Published: 2018;
46. Chirila, C.B. Programming Guide for the Silver Code Community, ELEARNING CHALLENGES AND NEW HORIZONS, VOL 4, Book Series: eLearning and Software for Education, Pages: 290-295, 14th International Scientific Conference on eLearning and Software for Education - eLearning Challenges and New Horizons, APR 19-20, 2018, Bucharest, ROMANIA, ISSN: 2066-026X, Published: 2018;
47. Chirila, C.B., Parain, G. Metamodels for Auto-Generative Learning Objects Dedicated to Unix Operating System Disciplines, 2018 22ND INTERNATIONAL CONFERENCE ON SYSTEM THEORY, CONTROL AND COMPUTING (ICSTCC), Book Series: International Conference on System Theory Control and Computing, Pages: 547-552, 22nd International Conference on System Theory, Control and Computing (ICSTCC), OCT 10-12, 2018, Sinaia, ROMANIA, ISSN: 2372-1618, ISBN: 978-1-5386-4444-7, Published: 2018;
48. Chis, L.G., Marcu, M., Dragan, F. Software Tool for Audio Signal Analysis and Automatic Music Transcription, 2018 IEEE 12TH INTERNATIONAL SYMPOSIUM ON APPLIED COMPUTATIONAL INTELLIGENCE AND INFORMATICS (SACI), Pages: 497-501, 12th IEEE International Symposium on Applied Computational Intelligence and Informatics (SACI), MAY 17-19, 2018, Timisoara, ROMANIA, ISBN: 978-1-5386-4640-3, Published: 2018;
49. Chis, V., Barbulescu, C., Kilyeni, S., Dzitac, S. Short-Term Load Forecasting Software Tool, 2018 7TH INTERNATIONAL CONFERENCE ON COMPUTERS COMMUNICATIONS AND CONTROL (ICCCC 2018), Pages: 111-118, 7th International Conference on Computers Communications and Control (ICCCC), MAY 08-12, 2018, Oradea, ROMANIA, ISBN: 978-1-5386-1934-6, Published: 2018;
50. Cirligeriu, L.E., Stan, A.T., Rominu, M., Marinescu, A., Boariu, M., Vaduva, A., Negrutiu, M.L., Sinescu, C., Duma, V.F., Nica, L. Evaluation of Biodentine - Tooth Structures Interfaces using Laser Scanning Confocal Microscopy, SEVENTH INTERNATIONAL CONFERENCE ON LASERS IN MEDICINE, Book Series: Proceedings of SPIE, Volume: 10831, Article Number: UNSP 108310Q, 7th Romanian-Society-for-Laser-in-Dentistry (SRLS) International Conference on Lasers in Medicine / 1st Congress of Laser in Dentistry, JUL 13-15, 2017, Timisoara, ROMANIA, ISSN: 0277-786X, eISSN: 1996-756X, ISBN: 978-1-5106-2288-3, Published: 2018;
51. Ciuclea, C., Prostean, G., Andone, D. New Learning and New Teaching in Higher Education. Formal vs. Informal Learning, SOFT COMPUTING APPLICATIONS, SOFA 2016, VOL 2, Book Series: Advances in Intelligent Systems and Computing, Volume: 634, Pages: 218-224, 7th International Workshop on Soft Computing Applications (SOFA), AUG 24-26, 2016, Arad, ROMANIA, ISSN: 2194-5357, eISSN: 2194-5365, ISBN: 978-3-319-62524-9, Published: 2018;
52. Ciuclea, C., Prostean, G., Andone, D., Draghici, A. Integrating E-learning Platforms in Teaching/Learning. A Critical Review Upon the Virtual Campus Usage in UPT, SOFT COMPUTING APPLICATIONS, SOFA 2016, VOL 2, Book Series: Advances in Intelligent Systems and Computing, Volume: 634, Pages: 225-234, 7th International Workshop on Soft Computing Applications (SOFA), AUG 24-26, 2016, Arad, ROMANIA, ISSN: 2194-5357, eISSN: 2194-5365, ISBN: 978-3-319-62524-9, Published: 2018;
53. Cosma, D.C., Gugea, O., Avramovic, T. ViMC - Interactive Tool for Measuring Software Applications, 2018 22ND INTERNATIONAL CONFERENCE ON SYSTEM THEORY, CONTROL AND COMPUTING (ICSTCC), Book Series: International Conference on System Theory Control and Computing, Pages: 397-402, 22nd International Conference on System Theory, Control and Computing (ICSTCC), OCT 10-12, 2018, Sinaia, ROMANIA, ISSN: 2372-1618, ISBN: 978-1-5386-4444-7, Published: 2018;
54. Cosnita, R. Improving Regional Radio Network through Design, Simulation and Implementation, 2018 13TH INTERNATIONAL SYMPOSIUM ON ELECTRONICS AND TELECOMMUNICATIONS (ISETC), Book Series: International Symposium on Electronics and Telecommunications, Pages: 187-190, 13th International Symposium on Electronics and Telecommunications (ISETC), NOV 08-09, 2018, Timisoara, ROMANIA, ISSN: 2475-787X, ISBN: 978-1-5386-5925-0, Published: 2018;
55. Costea, F.M., Chirila, C.B., Cretu, V.I. Auto-Generative Learning Objects for Middle School Arithmetic, ELEARNING CHALLENGES AND NEW HORIZONS, VOL 4, Book Series: eLearning and Software for Education, Pages: 311-318, 14th International Scientific Conference on eLearning and Software for Education - eLearning Challenges and New Horizons, APR 19-20, 2018, Bucharest, ROMANIA, ISSN: 2066-026X, Published: 2018;

56. Costea, F.M., Chirila, C.B., Cretu, V.I. Towards Auto-Generative Learning Objects for Industrial IT Services, 2018 IEEE 12TH INTERNATIONAL SYMPOSIUM ON APPLIED COMPUTATIONAL INTELLIGENCE AND INFORMATICS (SACI), Pages: 155-159, 12th IEEE International Symposium on Applied Computational Intelligence and Informatics (SACI), MAY 17-19, 2018, Timisoara, ROMANIA, ISBN: 978-1-5386-4640-3, Published: 2018;
57. Covaci, C., Gontean, A. SPICE Model of a Piezoelectric Transducer, 2018 IEEE 24TH INTERNATIONAL SYMPOSIUM FOR DESIGN AND TECHNOLOGY IN ELECTRONIC PACKAGING (SIITME), Book Series: International Symposium for Design and Technology in Electronic Packaging, Pages: 298-301, 24th IEEE International Symposium on Design and Technology in Electronic Packaging (SIITME), OCT 25-28, 2018, Iasi, ROMANIA, ISSN: 2641-287X, ISBN: 978-1-5386-5577-1, Published: 2018;
58. Cowell, S.R., Dragoi, V., Rohatinovici, N.C., Beiu, V. Effective conductances of Moore-Shannon hammocks, 2018 IEEE 18TH INTERNATIONAL CONFERENCE ON NANOTECHNOLOGY (IEEE-NANO), Book Series: IEEE International Conference on Nanotechnology, 18th IEEE International Conference on Nanotechnology (IEEE-NANO), JUL 23-26, 2018, Cork, IRELAND, ISSN: 1944-9399, eISSN: 1944-9380, ISBN: 978-1-5386-5336-4, Published: 2018;
59. Craciun, M., Csorba, L.M. Application of the Fuzzy-Pay-Off Method in the Valuation of a Financial Instrument, SOFT COMPUTING APPLICATIONS, SOFA 2016, VOL 2, Book Series: Advances in Intelligent Systems and Computing, Volume: 634, Pages: 235-250, 7th International Workshop on Soft Computing Applications (SOFA), AUG 24-26, 2016, Arad, ROMANIA, ISSN: 2194-5357, eISSN: 2194-5365, ISBN: 978-3-319-62524-9, Published: 2018;
60. Crastiu, I., Pop-Gozman, C., Berce, C., Simoiu, D., Deac, S., Bereteu, L. The Influence of the Mesh Element Size on the Natural Frequencies of Beam, 2018 IEEE 16TH INTERNATIONAL SYMPOSIUM ON INTELLIGENT SYSTEMS AND INFORMATICS (SISY 2018), Book Series: International Symposium on Intelligent Systems and Informatics, Pages: 137-141, IEEE 16th International Symposium on Intelligent Systems and Informatics (SISY), SEP 13-15, 2018, Subotica, SERBIA, ISSN: 1949-047X, ISBN: 978-1-5386-6841-2, Published: 2018;
61. Crastiu, I., Simoiu, D., Nyaguly, E., Bereteu, L. Determination of Flexural Critical Speed of a Rotor by Vibroacustical Signal Analysis, ACOUSTICS AND VIBRATION OF MECHANICAL STRUCTURES (AVMS-2017), Book Series: Springer Proceedings in Physics, Volume: 198, Pages: 295-303, 14th International Conference on Acoustics and Vibration of Mechanical Structures (AVMS), MAY 25-26, 2017, Timisoara, ROMANIA, ISSN: 0930-8989, eISSN: 1867-4941, ISBN: 978-3-319-69823-6; 978-3-319-69822-9, Published: 2018;
62. Crisan-Vida, M., Barbut, L., Barbut, A., Stoicu-Tivadar, L. IT Complex Solution Supporting Continuity of Care, SOFT COMPUTING APPLICATIONS, SOFA 2016, VOL 1, Book Series: Advances in Intelligent Systems and Computing, Volume: 633, Pages: 308-315, 7th International Workshop on Soft Computing Applications (SOFA), AUG 24-26, 2016, Arad, ROMANIA, ISSN: 2194-5357, eISSN: 2194-5365, ISBN: 978-3-319-62521-8, Published: 2018;
63. Csorba, L.M., Craciun, M. An Application of the Multi Period Decision Trees in the Sustainable Medical Waste Investments, SOFT COMPUTING APPLICATIONS, SOFA 2016, VOL 2, Book Series: Advances in Intelligent Systems and Computing, Volume: 634, Pages: 540-556, 7th International Workshop on Soft Computing Applications (SOFA), AUG 24-26, 2016, Arad, ROMANIA, ISSN: 2194-5357, eISSN: 2194-5365, ISBN: 978-3-319-62524-9, Published: 2018;
64. Csukas, E.S., Duma, V.F. Optical choppers with cylindrical rotational shafts for laser applications: A Finite Element Analysis, SENSORS, SYSTEMS, AND NEXT-GENERATION SATELLITES XXII, Book Series: Proceedings of SPIE, Volume: 10785, Article Number: UNSP 107851K, Conference on Sensors, Systems, and Next-Generation Satellites XXII, SEP 10-12, 2018, Berlin, GERMANY, ISSN: 0277-786X, eISSN: 1996-756X, ISBN: 978-1-5106-2154-1, Published: 2018;
65. Dan, A.M., Dragomir, T.L. State Feedback Control Models for the Cardiovascular System in Constant Exercise Scenario, 2018 IEEE 12TH INTERNATIONAL SYMPOSIUM ON APPLIED COMPUTATIONAL INTELLIGENCE AND INFORMATICS (SACI), Pages: 285-290, 12th IEEE International Symposium on Applied Computational Intelligence and Informatics (SACI), MAY 17-19, 2018, Timisoara, ROMANIA, ISBN: 978-1-5386-4640-3, Published: 2018;
66. Daneti, M. Low Cost Supportive Tool for Teaching Assistance in Formative Assessment Strategy, PROCEEDINGS OF 2018 IEEE GLOBAL ENGINEERING EDUCATION CONFERENCE (EDUCON) - EMERGING TRENDS AND CHALLENGES OF ENGINEERING EDUCATION, Book Series: IEEE Global Engineering Education Conference, Pages: 415-420, IEEE Global Engineering Education Conference (EDUCON) - Emerging Trends and Challenges of Engineering Education, APR 17-20, 2018, Santa Cruz de Tenerife, SPAIN, ISSN: 2165-9567, ISBN: 978-1-5386-2957-4, Published: 2018;



67. Dehelean, T., Naformita, C., Isar, A. OSPA Metric for Radar Extended Object Tracker, 2018 13TH INTERNATIONAL SYMPOSIUM ON ELECTRONICS AND TELECOMMUNICATIONS (ISETC), Book Series: International Symposium on Electronics and Telecommunications, Pages: 313-317, 13th International Symposium on Electronics and Telecommunications (ISETC), NOV 08-09, 2018, Timisoara, ROMANIA, ISSN: 2475-787X, ISBN: 978-1-5386-5925-0, Published: 2018;
68. Demonceau, J.F., Ciutina, A. Characterisation of beam-to-column joints beyond current Eurocode provisions, PROCEEDINGS OF THE 12TH INTERNATIONAL CONFERENCE ON ADVANCES IN STEEL-CONCRETE COMPOSITE STRUCTURES (ASCCS 2018), Pages: 513-520, 12th International Conference on Advances in Steel-Concrete Composite Structures (ASCCS), JUN 27-29, 2018, Valencia, SPAIN, ISBN: 978-84-9048-601-6, Published: 2018;
69. Diaconescu, A., Prostean, G., Tamasila, M., Vartosu, A. KNOWLEDGE TRANSFER FOR RENEWABLE ENERGY PROJECTS, PERFORMANCE MANAGEMENT OR MANAGEMENT PERFORMANCE?, Book Series: Review of Management and Economic Engineering International Management Conference, Pages: 591-598, 6th Review of Management and Economic Engineering International Management Conference, SEP 20-22, 2018, Cluj Napoca, ROMANIA, ISSN: 2247-8639, Published: 2018;
70. Dicu, N., Andreescu, G.D., Gurban, E.H. Automotive Dead-Reckoning Navigation System Based on Vehicle Speed and Yaw Rate, 2018 IEEE 12TH INTERNATIONAL SYMPOSIUM ON APPLIED COMPUTATIONAL INTELLIGENCE AND INFORMATICS (SACI), Pages: 225-228, 12th IEEE International Symposium on Applied Computational Intelligence and Informatics (SACI), MAY 17-19, 2018, Timisoara, ROMANIA, ISBN: 978-1-5386-4640-3, Published: 2018;
71. Dinu, F., Marginean, I., Dubina, D., Khalil, A., De luliis, E. Factors affecting the response of steel columns to close-in detonations, PROCEEDINGS OF THE 12TH INTERNATIONAL CONFERENCE ON ADVANCES IN STEEL-CONCRETE COMPOSITE STRUCTURES (ASCCS 2018), Pages: 873-880, 12th International Conference on Advances in Steel-Concrete Composite Structures (ASCCS), JUN 27-29, 2018, Valencia, SPAIN, ISBN: 978-84-9048-601-6, Published: 2018;
72. Dolga, L., Filipescu, H., Moldovan, C., Alexa, F., Frigura-Iliasa, M. Computer Aided Design and Model of a Car Tire Pressure Module Antenna, 2018 IEEE RADIO AND ANTENNA DAYS OF THE INDIAN OCEAN (RADIO), IEEE Radio and Antenna Days of the Indian Ocean (RADIO), OCT 15-18, 2018, MAURITIUS, ISBN: 978-99949-0-470-9, Published: 2018;
73. Dragan, C.M. Natural Convection in Car Environment Conditions, 2018 24TH INTERNATIONAL WORKSHOP ON THERMAL INVESTIGATIONS OF ICS AND SYSTEMS (THERMINIC), 24th International Workshop on Thermal Investigations of ICs and Systems (THERMINIC), SEP 26-28, 2018, Stockholm, SWEDEN, ISBN: 978-1-5386-6759-0, Published: 2018;
74. Dufour, C.M., Draghici, A. Gas distribution companies: How can knowledge management promote occupational health and safety?, OCCUPATIONAL SAFETY AND HYGIENE VI, Pages: 607-611, 6th International Symposium on Occupational Safety and Hygiene (SHO), MAR 26-27, 2018, Guimaraes, PORTUGAL, ISBN: 978-1-351-00888-4; 978-1-138-54203-7, Published: 2018;
75. Duma, M.S., Duma, V.F. Testing of optical choppers using laser lines, OPTICAL SENSING AND DETECTION V, Book Series: Proceedings of SPIE, Volume: 10680, Article Number: 106802A, Conference on Optical Sensing and Detection V, APR 23-26, 2018, Strasbourg, FRANCE, ISSN: 0277-786X, eISSN: 1996-756X, ISBN: 978-1-5106-1887-9, Published: 2018;
76. Ene, R.D., Petrisor, C., Pop, C. Approximate Analytic Solutions for an Optimal Control System on the Lie Group  $SO(3) \times R-3 \times R-3$ , INTERNATIONAL CONFERENCE OF NUMERICAL ANALYSIS AND APPLIED MATHEMATICS (ICNAAM 2017), Book Series: AIP Conference Proceedings, Volume: 1978, Article Number: UNSP 390004-1, International Conference of Numerical Analysis and Applied Mathematics (ICNAAM), SEP 25-30, 2017, Thessaloniki, GREECE, ISSN: 0094-243X, ISBN: 978-0-7354-1690-1, Published: 2018;
77. Erofei, A.A., Druta, C.F., Căleanu, C.D. Embedded Solutions for Deep Neural Networks Implementation, 2018 IEEE 12TH INTERNATIONAL SYMPOSIUM ON APPLIED COMPUTATIONAL INTELLIGENCE AND INFORMATICS (SACI), Pages: 425-429, 12th IEEE International Symposium on Applied Computational Intelligence and Informatics (SACI), MAY 17-19, 2018, Timisoara, ROMANIA, ISBN: 978-1-5386-4640-3, Published: 2018;
78. Everson, M., Duma, V.F., Dobre, G. Optimisation of a polygon mirror-based, spectral filter for Swept Source Optical Coherence Tomography (SS-OCT), 2ND CANTERBURY CONFERENCE ON OCT WITH EMPHASIS ON BROADBAND OPTICAL SOURCES, Book Series: Proceedings of SPIE, Volume: 10591, Article Number: UNSP 105910V, 2nd Canterbury Conference on Optical Coherence Tomography with Emphasis on Broadband Optical Sources (CCOCT), SEP 06-08, 2017, Canterbury, ENGLAND, ISSN: 0277-786X, eISSN: 1996-756X, ISBN: 978-1-5106-1675-2; 978-1-5106-1674-5, Published: 2018;

79. Everson, M., Duma, V.F., Dobre, G. Performance enhancements from telescope optics in a polygon mirror-based, spectral filter for Swept Source Optical Coherence Tomography (SS-OCT), OPTICAL INSTRUMENT SCIENCE, TECHNOLOGY, AND APPLICATIONS, Book Series: Proceedings of SPIE, Volume: 10695, Article Number: UNSP 1069507, 1st Conference on Optical Instrument Science, Technology, and Applications at the SPIE European Optical Design Conference, MAY 14-15, 2018, Frankfurt, GERMANY, ISSN: 0277-786X, eISSN: 1996-756X, ISBN: 978-1-5106-1928-9, Published: 2018;
80. Everson, M., Duma, V.F., Dobre, G. Aspects of vignetting in a polygon mirror-based spectral filter for Swept Source Optical Coherence Tomography (SS-OCT), SEVENTH INTERNATIONAL CONFERENCE ON LASERS IN MEDICINE, Book Series: Proceedings of SPIE, Volume: 10831, Article Number: UNSP 108310L, 7th Romanian-Society-for-Laser-in-Dentistry (SRLS) International Conference on Lasers in Medicine / 1st Congress of Laser in Dentistry, JUL 13-15, 2017, Timisoara, ROMANIA, ISSN: 0277-786X, eISSN: 1996-756X, ISBN: 978-1-5106-2288-3, Published: 2018;
81. Farkas, A.Z., Argesanu, V., Maniu, I., Borozan, I.S. Kulcsar, R.M., Patrascu (Domokos), S.C., Borozan (Stanciu), S. Biomechanical simulation of different postures obtained from three sport branches, 2018 IEEE 16TH INTERNATIONAL SYMPOSIUM ON INTELLIGENT SYSTEMS AND INFORMATICS (SISY 2018), Book Series: International Symposium on Intelligent Systems and Informatics, Pages: 305-309, IEEE 16th International Symposium on Intelligent Systems and Informatics (SISY), SEP 13-15, 2018, Subotica, SERBIA, ISSN: 1949-047X, ISBN: 978-1-5386-6841-2, Published: 2018;
82. Filip, B., Frigura-Iliasa, F.M., Vatau, D., Frigura-Iliasa, M., Andea, P., Balcu, I.F. Experimental Improvements Concerning the Thermal Manufacturing Parameters of a New Metal Oxide Varistor Material, 2018 IEEE INTERNATIONAL CONFERENCE ON ENVIRONMENT AND ELECTRICAL ENGINEERING AND 2018 IEEE INDUSTRIAL AND COMMERCIAL POWER SYSTEMS EUROPE (EEEIC / I&CPS EUROPE), IEEE International Conference on Environment and Electrical Engineering / IEEE Industrial and Commercial Power Systems Europe (EEEIC / I&CPS Europe), JUN 12-15, 2018, Palermo, ITALY, ISBN: 978-1-5386-5186-5, Published: 2018;
83. Filip, I., Szeidert, I., Prosteian, O., Vasar, C. Issues Regarding the Tuning of a Minimum Variance Adaptive Controller, SOFT COMPUTING APPLICATIONS, SOFA 2016, VOL 1, Book Series: Advances in Intelligent Systems and Computing, Volume: 633, Pages: 70-77, 7th International Workshop on Soft Computing Applications (SOFA), AUG 24-26, 2016, Arad, ROMANIA, ISSN: 2194-5357, eISSN: 2194-5365, ISBN: 978-3-319-62521-8, Published: 2018;
84. Filipescu, H., Dolga, L., Moldovan, C., Alexa, F., Frigura-Iliasa, M. Computer Aided Design and Model of a Remote Keyless Module Antenna, 2018 IEEE RADIO AND ANTENNA DAYS OF THE INDIAN OCEAN (RADIO), IEEE Radio and Antenna Days of the Indian Ocean (RADIO), OCT 15-18, 2018, MAURITIUS, ISBN: 978-99949-0-470-9, Published: 2018;
85. Foris, D., Tokar, D., Tokar, A., Foris, T. SUSTAINABLE RURAL DEVELOPMENT THROUGH IMPROVING WATER SUPPLY IN MOUNTAIN HUTS, RURAL DEVELOPMENT AND ENTREPRENEURSHIP PRODUCTION AND CO-OPERATION IN AGRICULTURE, Book Series: Economic Science for Rural Development, Volume: 47, Pages: 81-88, 19th International Scientific Conference on Economic Science for Rural Development, MAY 09-11, 2018, Jelgava, LATVIA, ISSN: 1691-3078, ISBN: 978-9984-48-292-7, Published: 2018;
86. Gal, A., Filip, I., Dragan, F. IoTThings: A Platform for Building up the Internet of Things, SOFT COMPUTING APPLICATIONS, SOFA 2016, VOL 1, Book Series: Advances in Intelligent Systems and Computing, Volume: 633, Pages: 176-188, 7th International Workshop on Soft Computing Applications (SOFA), AUG 24-26, 2016, Arad, ROMANIA, ISSN: 2194-5357, eISSN: 2194-5365, ISBN: 978-3-319-62521-8, Published: 2018;
87. Gal-Nadasan, N., Crisan-Vida, M., Stoicu-Tivadar, V., Gradea, A., Gal-Nadasan, E. Computer Assisted Oswestry Disability Questionnaire Evaluation Using Fuzzy Inference Systems, DECISION SUPPORT SYSTEMS AND EDUCATION: HELP AND SUPPORT IN HEALTHCARE, Book Series: Studies in Health Technology and Informatics, Volume: 255, Pages: 147-151, PubMed ID: 30306925, Special Topic Conference of the European-Federation-for-Medical-Informatics (EFMI STC), OCT 15-16, 2018, Zagreb, CROATIA, ISSN: 0926-9630, eISSN: 1879-8365, ISBN: 978-1-61499-921-8; 978-1-61499-920-1, Published: 2018;
88. Gal-Nadasan, N., Stoicu-Tivadar, V., Poenaru, D.V., Popa-Andrei, D., Gal-Nadasan, E. Computer Aided Posture Screening Using the Microsoft Kinect on Professional Computer Users for Malicious Postures, SOFT COMPUTING APPLICATIONS, SOFA 2016, VOL 1, Book Series: Advances in Intelligent Systems and Computing, Volume: 633, Pages: 298-307, 7th International Workshop on Soft Computing Applications (SOFA), AUG 24-26, 2016, Arad, ROMANIA, ISSN: 2194-5357, eISSN: 2194-5365, ISBN: 978-3-319-62521-8, Published: 2018;

89. Gasparesc, G. Driver Alcohol Detection System Based on Virtual Instrumentation, IFAC PAPERSONLINE, Volume: 51, Issue: 6, Pages: 502-507, 15th IFAC/IEEE Conference on Programmable Devices and Embedded Systems (PDeS), MAY 23-25, 2018, Ostrava, CZECH REPUBLIC, ISSN: 2405-8963, Published: 2018;
90. Gavruta, A., Marcu, M., Bogdan, R. Software Solution for Monitoring and Analyzing Driver Behavior, 2018 IEEE 12TH INTERNATIONAL SYMPOSIUM ON APPLIED COMPUTATIONAL INTELLIGENCE AND INFORMATICS (SACI), Pages: 345-349, 12th IEEE International Symposium on Applied Computational Intelligence and Informatics (SACI), MAY 17-19, 2018, Timisoara, ROMANIA, ISBN: 978-1-5386-4640-3, Published: 2018;
91. Georgescu, D., Stanciu, L. Designing and Implementing a Solution to Manipulate Signals in Automated Testing Using CANoe, 2018 IEEE 12TH INTERNATIONAL SYMPOSIUM ON APPLIED COMPUTATIONAL INTELLIGENCE AND INFORMATICS (SACI), Pages: 309-312, 12th IEEE International Symposium on Applied Computational Intelligence and Informatics (SACI), MAY 17-19, 2018, Timisoara, ROMANIA, ISBN: 978-1-5386-4640-3, Published: 2018;
92. Ghiormez, L., Prosteau, O., Filip, I., Panoiu, M. Fuzzy Logic Control Strategy for a Three-Phase Electric Arc Furnace, SOFT COMPUTING APPLICATIONS, SOFA 2016, VOL 2, Book Series: Advances in Intelligent Systems and Computing, Volume: 634, Pages: 253-264, 7th International Workshop on Soft Computing Applications (SOFA), AUG 24-26, 2016, Arad, ROMANIA, ISSN: 2194-5357, eISSN: 2194-5365, ISBN: 978-3-319-62524-9, Published: 2018;
93. Gontean, A., Otesteanu, M., Babaita, M. Enhancing the Output Current of a Simple Switcher Analysis, 2018 13TH INTERNATIONAL SYMPOSIUM ON ELECTRONICS AND TELECOMMUNICATIONS (ISETC), Book Series: International Symposium on Electronics and Telecommunications, Pages: 82-85, 13th International Symposium on Electronics and Telecommunications (ISETC), NOV 08-09, 2018, Timisoara, ROMANIA, ISSN: 2475-787X, ISBN: 978-1-5386-5925-0, Published: 2018;
94. Greconici, M., Madescu, G., Mot, M., Biriescu, M., Milosevici, D. Analysis of a PM Generator with Inset Magnets, 2018 13TH INTERNATIONAL SYMPOSIUM ON ELECTRONICS AND TELECOMMUNICATIONS (ISETC), Book Series: International Symposium on Electronics and Telecommunications, Pages: 78-81, 13th International Symposium on Electronics and Telecommunications (ISETC), NOV 08-09, 2018, Timisoara, ROMANIA, ISSN: 2475-787X, ISBN: 978-1-5386-5925-0, Published: 2018;
95. Groza, B., Briceag, C. A Vehicle Collision-Warning System Based on Multipeer Connectivity and Off-the-Shelf Smart-Devices, RISKS AND SECURITY OF INTERNET AND SYSTEMS, CRISIS 2017, Book Series: Lecture Notes in Computer Science, Volume: 10694, Pages: 115-123, 12th International Conference on Risks and Security of Internet and Systems (CRISIS), SEP 19-21, 2017, Dinard, FRANCE, ISSN: 0302-9743, eISSN: 1611-3349, ISBN: 978-3-319-76687-4; 978-3-319-76686-7, Published: 2018;
96. Gruescu, D.T., Cismas, L.M. SYSTEMIC ANALYSIS OF CREDIT CONTRACTS FROM THE PERSPECTIVE OF ABUSIVE CLAUSES, 2018 IEEE 12TH INTERNATIONAL SYMPOSIUM ON APPLIED COMPUTATIONAL INTELLIGENCE AND INFORMATICS (SACI), Pages: 33-38, 12th IEEE International Symposium on Applied Computational Intelligence and Informatics (SACI), MAY 17-19, 2018, Timisoara, ROMANIA, ISBN: 978-1-5386-4640-3, Published: 2018;
97. Gruescu, D.T. Access to justice for the protection of pensioners' rights using fuzzy logic, 2018 IEEE 12TH INTERNATIONAL SYMPOSIUM ON APPLIED COMPUTATIONAL INTELLIGENCE AND INFORMATICS (SACI), Pages: 21-26, 12th IEEE International Symposium on Applied Computational Intelligence and Informatics (SACI), MAY 17-19, 2018, Timisoara, ROMANIA, ISBN: 978-1-5386-4640-3, Published: 2018;
98. Gruicin, I., Ionascu, M.E., Popa, M. A Solution for Air Quality Monitoring and Forecasting, 2018 IEEE 12TH INTERNATIONAL SYMPOSIUM ON APPLIED COMPUTATIONAL INTELLIGENCE AND INFORMATICS (SACI), Pages: 503-507, 12th IEEE International Symposium on Applied Computational Intelligence and Informatics (SACI), MAY 17-19, 2018, Timisoara, ROMANIA, ISBN: 978-1-5386-4640-3, Published: 2018;
99. Gurbina, M., Pop-Calimanu, I.M., Lascu, D., Lica, S., Ciresan, A. Exact Stability Analysis of a Two-Phase Boost Converter, 2018 41ST INTERNATIONAL CONFERENCE ON TELECOMMUNICATIONS AND SIGNAL PROCESSING (TSP), Pages: 334-337, 41st International Conference on Telecommunications and Signal Processing (TSP), JUL 04-06, 2018, Athens, GREECE, ISBN: 978-1-5386-4695-3, Published: 2018;
100. Haiducu, C.G., Bujanca, A.M., Lie, I. Automatic testing of automotive electronic modules for cranking conditions, 2018 13TH INTERNATIONAL SYMPOSIUM ON ELECTRONICS AND TELECOMMUNICATIONS (ISETC), Book Series: International Symposium on Electronics and Telecommunications, Pages: 48-51, 13th International Symposium on Electronics and Telecommunications (ISETC), NOV 08-09, 2018, Timisoara, ROMANIA, ISSN: 2475-787X, ISBN: 978-1-5386-5925-0, Published: 2018;

101. Hedes, A., Svoboda, M., Anton, L.E., Vitan, D., Muntean, S. In situ measurements on the electrical motors of hydraulic pumps installed in a wastewater station, 2018 IEEE INTERNATIONAL CONFERENCE ON ENVIRONMENT AND ELECTRICAL ENGINEERING AND 2018 IEEE INDUSTRIAL AND COMMERCIAL POWER SYSTEMS EUROPE (EEEIC / I&CPS EUROPE), IEEE International Conference on Environment and Electrical Engineering / IEEE Industrial and Commercial Power Systems Europe (EEEIC / I&CPS Europe), JUN 12-15, 2018, Palermo, ITALY, ISBN: 978-1-5386-5186-5, Published: 2018;
102. Hedrea, E.L., Bojan-Dragos, C.A., Precup, R.E., Petriu, E.M. Comparative Study of Control Structures for Maglev Systems, 2018 IEEE 18TH INTERNATIONAL POWER ELECTRONICS AND MOTION CONTROL CONFERENCE (PEMC), Book Series: IEEE International Power Electronics and Motion Control Conference IPEMC, Pages: 657-662, 18th IEEE International Power Electronics and Motion Control Conference (IEEE PEMC), AUG 26-30, 2018, Budapest, HUNGARY, ISBN: 978-1-5386-4198-9, Published: 2018;
103. Hedrea, E.L., Precup, R.E., Bojan-Dragos, C.A., Hedrea, C. Tensor Product-Based Model Transformation Technique Applied to Modeling Vertical Three Tank Systems, 2018 IEEE 12TH INTERNATIONAL SYMPOSIUM ON APPLIED COMPUTATIONAL INTELLIGENCE AND INFORMATICS (SACI), Pages: 63-68, 12th IEEE International Symposium on Applied Computational Intelligence and Informatics (SACI), MAY 17-19, 2018, Timisoara, ROMANIA, ISBN: 978-1-5386-4640-3, Published: 2018;
104. Hedrea, E.L., Precup, R.E., Bojan-Dragos, C.A., Roman, R.C., Tanasoiu, O., Marinescu, M. Cascade Control Solutions for Maglev Systems, 2018 22ND INTERNATIONAL CONFERENCE ON SYSTEM THEORY, CONTROL AND COMPUTING (ICSTCC), Book Series: International Conference on System Theory Control and Computing, Pages: 20-26, 22nd International Conference on System Theory, Control and Computing (ICSTCC), OCT 10-12, 2018, Sinaia, ROMANIA, ISSN: 2372-1618, ISBN: 978-1-5386-4444-7, Published: 2018;
105. Herisanu, N., Marinca, V. Free Oscillations of Euler-Bernoulli Beams on Nonlinear Winkler-Pasternak Foundation, ACOUSTICS AND VIBRATION OF MECHANICAL STRUCTURES (AVMS-2017), Book Series: Springer Proceedings in Physics, Volume: 198, Pages: 41-48, 14th International Conference on Acoustics and Vibration of Mechanical Structures (AVMS), MAY 25-26, 2017, Timisoara, ROMANIA, ISSN: 0930-8989, eISSN: 1867-4941, ISBN: 978-3-319-69823-6; 978-3-319-69822-9, Published: 2018;
106. Herisanu, N., Marinca, V. Analysis of Nonlinear Dynamic Behavior of a Rotating Electrical Machine Rotor-Bearing System Using Optimal Auxiliary Functions Method, DYNAMICAL SYSTEMS IN APPLICATIONS, Book Series: Springer Proceedings in Mathematics & Statistics, Volume: 249, Pages: 159-168, 14th International Conference on Dynamical Systems - Theory and Applications (DSTA) - Recent Developments in Mathematical Modelling of Dynamical Systems, DEC 11-14, 2017, Lodz, POLAND, ISSN: 2194-1009, ISBN: 978-3-319-96601-4, Published: 2018;
107. Herisanu, N., Marinca, V. Analytic Solution of the Static Pull-in Instability in MEMS Considering Casimir Force, INTERNATIONAL CONFERENCE OF NUMERICAL ANALYSIS AND APPLIED MATHEMATICS (ICNAAM 2017), Book Series: AIP Conference Proceedings, Volume: 1978, Article Number: UNSP 310003-1, International Conference of Numerical Analysis and Applied Mathematics (ICNAAM), SEP 25-30, 2017, Thessaloniki, GREECE, ISSN: 0094-243X, ISBN: 978-0-7354-1690-1, Published: 2018;
108. Herisanu, N., Marinca, V. Optimal homotopy asymptotic method to large post-buckling deformation of MEMS, INTERNATIONAL CONFERENCE ON ENGINEERING VIBRATION (ICOEV 2017), Book Series: MATEC Web of Conferences, Volume: 148, Article Number: UNSP 13003, International Conference on Engineering Vibration (ICoEV), SEP 04-07, 2017, Sofia, BULGARIA, ISSN: 2261-236X, Published: 2018;
109. Holotescu, V., Andone, D., Vasiiu, R. Developing hybrid mobile applications for learning, 2018 13TH INTERNATIONAL SYMPOSIUM ON ELECTRONICS AND TELECOMMUNICATIONS (ISETC), Book Series: International Symposium on Electronics and Telecommunications, Pages: 347-350, 13th International Symposium on Electronics and Telecommunications (ISETC), NOV 08-09, 2018, Timisoara, ROMANIA, ISSN: 2475-787X, ISBN: 978-1-5386-5925-0, Published: 2018;
110. Hulea, D., Cornea, O., Muntean, N. Energy Management Strategy for Supercapacitor Storage using a Nonlinear Virtual Impedance, 2018 IEEE 18TH INTERNATIONAL POWER ELECTRONICS AND MOTION CONTROL CONFERENCE (PEMC), Book Series: IEEE International Power Electronics and Motion Control Conference IPEMC, Pages: 375-380, 18th IEEE International Power Electronics and Motion Control Conference (IEEE PEMC), AUG 26-30, 2018, Budapest, HUNGARY, ISBN: 978-1-5386-4198-9, Published: 2018;
111. Hulea, D., Fahimi, B., Muntean, N., Cornea, O. High Ratio Bidirectional Hybrid Switched Inductor Converter using Wide Bandgap Transistors, 2018 20TH EUROPEAN CONFERENCE ON POWER ELECTRONICS AND APPLICATIONS (EPE'18 ECCE EUROPE), Book Series: European Conference on Power Electronics and Applications, 20th European Conference on Power Electronics and Applications (EPE ECCE Europe), SEP 17-21, 2018, Riga, LATVIA, ISSN: 2325-0313, ISBN: 978-9-0758-1528-3, Published: 2018;

112. Hutiu, G., Dimb, A.L., Duma, V.F., Demian, D., Bradu, A., Podoleanu, A.G. Roughness measurements using optical coherence tomography: A preliminary study, SEVENTH INTERNATIONAL CONFERENCE ON LASERS IN MEDICINE, Book Series: Proceedings of SPIE, Volume: 10831, Article Number: UNSP 108310S, 7th Romanian-Society-for-Laser-in-Dentistry (SRLS) International Conference on Lasers in Medicine / 1st Congress of Laser in Dentistry, JUL 13-15, 2017, Timisoara, ROMANIA, ISSN: 0277-786X, eISSN: 1996-756X, ISBN: 978-1-5106-2288-3, Published: 2018;
113. Iacobici, N.L., Cazacu, E., Frigura-Iliasa, M., Frigura-Iliasa, F.M. Feedback Type Computer Simulated Control Model for a Permanent Magnet Measuring System, 2018 IEEE 16TH WORLD SYMPOSIUM ON APPLIED MACHINE INTELLIGENCE AND INFORMATICS (SAMI 2018): DEDICATED TO THE MEMORY OF PIONEER OF ROBOTICS ANTAL (TONY) K. BEJCZY, Pages: 33-36, IEEE 16th World Symposium on Applied Machine Intelligence and Informatics (SAMI) Dedicated to the Memory of Pioneer of Robotics Antal (Tony) K. Bejczy, FEB 07-10, 2018, Kosice, SLOVAKIA, ISBN: 978-1-5386-4772-1, Published: 2018;
114. Iancu, C.A., Ceccarelli, M., Lovasz, E.C. Design and Lab Tests of a Scaled Leg Exoskeleton with Electric Actuators, ADVANCES IN SERVICE AND INDUSTRIAL ROBOTICS, Book Series: Mechanisms and Machine Science, Volume: 49, Pages: 719-726, 26th International Conference on Robotics in Alpe-Adria-Danube Region (RAAD), JUN 21-23, 2017, Turin, ITALY, ISSN: 2211-0984, eISSN: 2211-0992, ISBN: 978-3-319-61276-8; 978-3-319-61275-1, Published: 2018;
115. Ionascu, M.E., Gruicin, I., Marcu, M. Laboratory Evaluation and Calibration of Low-Cost Sensors for Air Quality Measurement, 2018 IEEE 12TH INTERNATIONAL SYMPOSIUM ON APPLIED COMPUTATIONAL INTELLIGENCE AND INFORMATICS (SACI), Pages: 395-400, 12th IEEE International Symposium on Applied Computational Intelligence and Informatics (SACI), MAY 17-19, 2018, Timisoara, ROMANIA, ISBN: 978-1-5386-4640-3, Published: 2018;
116. Ionascu, M.E., Gruicin, I., Marcu, M. Towards Wearable Air Quality Monitoring Systems - Initial Assessments on Newly Developed Sensors, 2018 26TH TELECOMMUNICATIONS FORUM (TELFOR), Pages: 571-574, 26th Telecommunications Forum (TELFOR), NOV 20-21, 2018, Belgrade, SERBIA, ISBN: 978-1-5386-7171-9, Published: 2018;
117. Ionel, R., Demian, P. A solution for integrating the Vector CANCase XL with the Teradyne Test Station ICT, 2018 13TH INTERNATIONAL SYMPOSIUM ON ELECTRONICS AND TELECOMMUNICATIONS (ISETC), Book Series: International Symposium on Electronics and Telecommunications, Pages: 25-28, 13th International Symposium on Electronics and Telecommunications (ISETC), NOV 08-09, 2018, Timisoara, ROMANIA, ISSN: 2475-787X, ISBN: 978-1-5386-5925-0, Published: 2018;
118. Ionescu, D., Kovaci, M. Performances of a metamaterial based on semiconductors for solar cell applications, 2018 13TH INTERNATIONAL SYMPOSIUM ON ELECTRONICS AND TELECOMMUNICATIONS (ISETC), Book Series: International Symposium on Electronics and Telecommunications, Pages: 164-167, 13th International Symposium on Electronics and Telecommunications (ISETC), NOV 08-09, 2018, Timisoara, ROMANIA, ISSN: 2475-787X, ISBN: 978-1-5386-5925-0, Published: 2018;
119. Isfanuti, A.S., Paicu, M.C., Tutelea, L.N., Staudt, T., Boldea, I. V/f with stabilizing loops versus FOC of Spoke-PM rotor SM drive: control with experiments, 2018 IEEE 18TH INTERNATIONAL POWER ELECTRONICS AND MOTION CONTROL CONFERENCE (PEMC), Book Series: IEEE International Power Electronics and Motion Control Conference IPEMC, Pages: 629-636, 18th IEEE International Power Electronics and Motion Control Conference (IEEE PEMC), AUG 26-30, 2018, Budapest, HUNGARY, ISBN: 978-1-5386-4198-9, Published: 2018;
120. Jonietz, C., Jivet, I. Touchless Fingerprint Capturing from RGB-D Images in Mobile Devices, 2018 13TH INTERNATIONAL SYMPOSIUM ON ELECTRONICS AND TELECOMMUNICATIONS (ISETC), Book Series: International Symposium on Electronics and Telecommunications, Pages: 7-10, 13th International Symposium on Electronics and Telecommunications (ISETC), NOV 08-09, 2018, Timisoara, ROMANIA, ISSN: 2475-787X, ISBN: 978-1-5386-5925-0, Published: 2018;
121. Jurcau, D.A., Stoicu-Tivadar, V. Evaluating the User Experience of a Web Application for Managing Electronic Health Records, SOFT COMPUTING APPLICATIONS, SOFA 2016, VOL 1, Book Series: Advances in Intelligent Systems and Computing, Volume: 633, Pages: 276-289, 7th International Workshop on Soft Computing Applications (SOFA), AUG 24-26, 2016, Arad, ROMANIA, ISSN: 2194-5357, eISSN: 2194-5365, ISBN: 978-3-319-62521-8, Published: 2018;
122. Jurj, S.L., Opritoiu, F., Vladutiu, M. Identification of Traditional Motifs using Convolutional Neural Networks, 2018 IEEE 24TH INTERNATIONAL SYMPOSIUM FOR DESIGN AND TECHNOLOGY IN ELECTRONIC PACKAGING (SIITME), Book Series: International Symposium for Design and Technology in Electronic Packaging, Pages: 191-196, 24th IEEE International Symposium on Design and Technology in Electronic Packaging (SIITME), OCT 25-28, 2018, Iasi, ROMANIA, ISSN: 2641-287X, ISBN: 978-1-5386-5577-1, Published: 2018;

123. Jurj, S.L., Rotar, R., Opritoiu, F., Vladutiu, M. White-Box Testing Strategy for a Solar Tracking Device using NodeMCU Lua ESP8266 Wi-Fi Network Development Board Module, 2018 IEEE 24TH INTERNATIONAL SYMPOSIUM FOR DESIGN AND TECHNOLOGY IN ELECTRONIC PACKAGING (SIITME), Book Series: International Symposium for Design and Technology in Electronic Packaging, Pages: 53-60, 24th IEEE International Symposium on Design and Technology in Electronic Packaging (SIITME), OCT 25-28, 2018, Iasi, ROMANIA, ISSN: 2641-287X, ISBN: 978-1-5386-5577-1, Published: 2018;
124. Khoa, L., Ghaffari, F., Kessal, L., Declercq, D., Savin, V., Boncalo, O. Lightweight Hardware Architecture for Probabilistic Gradient Descent Bit Flipping on QC-LDPC Codes, 2018 IEEE INTERNATIONAL SYMPOSIUM ON CIRCUITS AND SYSTEMS (ISCAS), Book Series: IEEE International Symposium on Circuits and Systems, IEEE International Symposium on Circuits and Systems (ISCAS), MAY 27-30, 2018, Florence, ITALY, ISSN: 0271-4302, ISBN: 978-1-5386-4881-0, Published: 2018;
125. Kiss, A., Mihancea, P.F. Towards Feature Envy Design Flaw Detection at Block Level, PROCEEDINGS 2018 IEEE INTERNATIONAL CONFERENCE ON SOFTWARE MAINTENANCE AND EVOLUTION (ICSME), Book Series: Proceedings-IEEE International Conference on Software Maintenance, Pages: 544-548, IEEE International Conference on Software Maintenance and Evolution (ICSME), SEP 23-29, 2018, Madrid, SPAIN, ISSN: 1063-6773, ISBN: 978-1-5386-7870-1, Published: 2018;
126. Korodi, A., Radu, M.A., Crisan, R. Non-Invasive Control Solution inside Higher-Level OPC UA based Wrapper for Optimizing Groups of Wastewater Systems, 2018 IEEE 23RD INTERNATIONAL CONFERENCE ON EMERGING TECHNOLOGIES AND FACTORY AUTOMATION (ETFA), Book Series: IEEE International Conference on Emerging Technologies and Factory Automation-ETFA, Pages: 597-604, 23rd IEEE International Conference on Emerging Technologies and Factory Automation (ETFA), SEP 04-07, 2018, Torino, ITALY, ISSN: 1946-0740, ISBN: 978-1-5386-7108-5, Published: 2018;
127. Lacrama, D.L., Alexa, F., Pinte, F.A., Karnyanszky, T.M. Brain - Machine Interfaces in the Context of Artificial Intelligence Development, 2018 14TH SYMPOSIUM ON NEURAL NETWORKS AND APPLICATIONS (NEUREL), 14th Symposium on Neural Networks and Applications (NEUREL), NOV 20-21, 2018, Belgrade, SERBIA, ISBN: 978-1-5386-6974-7, Published: 2018;
128. Lascu, C., Serban, E., Pondiche, C., Dragicevic, T. Anticipative Sorting Control of Modular Multilevel Converters, 2018 IEEE ENERGY CONVERSION CONGRESS AND EXPOSITION (ECCE), Book Series: IEEE Energy Conversion Congress and Exposition, Pages: 678-685, 10th IEEE Annual Energy Conversion Congress and Exposition (ECCE), SEP 23-27, 2018, Portland, OR, ISSN: 2329-3721, ISBN: 978-1-4799-7312-5, Published: 2018;
129. Lazarescu, E., Rimescu, C., Frigura-Iliasa, F.M., Dolga, L., Filipescu, H.E., Anghel, A.A. CAD Project of a Class D Surge Arrester Module for Domestic and Residential Low Voltage Applications, PROCEEDINGS OF THE 2018 19TH INTERNATIONAL SCIENTIFIC CONFERENCE ON ELECTRIC POWER ENGINEERING (EPE), Book Series: International Scientific Conference on Electric Power Engineering, Pages: 216-219, 19th International Scientific Conference on Electric Power Engineering (EPE), MAY 16-18, 2018, Brno, CZECH REPUBLIC, ISSN: 2376-5623, ISBN: 978-1-5386-4612-0, Published: 2018;
130. Liang, J.C., Parsapour, A., Cosoroaba, E., Wu, M.X., Boldea, I., Fahimi, B. A High Torque Density Outer Rotor Claw Pole Stator Permanent Magnet Synchronous Motor, 2018 IEEE TRANSPORTATION AND ELECTRIFICATION CONFERENCE AND EXPO (ITEC), Book Series: IEEE Transportation Electrification Conference and Expo, Pages: 389-393, IEEE Transportation and Electrification Conference and Expo (ITEC), JUN 13-15, 2018, Long Beach, CA, ISSN: 2377-5483, eISSN: 2473-7631, ISBN: 978-1-5386-3048-8, Published: 2018;
131. Lica, S., Pop-Calimanu, I.M., Lascu, D., Popescu, S., Tomoroga, M., Ciresan, A. A New Hybrid Cuk Converter, 2018 13TH INTERNATIONAL SYMPOSIUM ON ELECTRONICS AND TELECOMMUNICATIONS (ISETC), Book Series: International Symposium on Electronics and Telecommunications, Pages: 133-136, 13th International Symposium on Electronics and Telecommunications (ISETC), NOV 08-09, 2018, Timisoara, ROMANIA, ISSN: 2475-787X, ISBN: 978-1-5386-5925-0, Published: 2018;
132. Lovasz, E.A., Lascu, D. A General Approach for Deriving the Sliding Mode State-Space Equation in Second Order CCM Operated DC-DC Converters, 2018 13TH INTERNATIONAL SYMPOSIUM ON ELECTRONICS AND TELECOMMUNICATIONS (ISETC), Book Series: International Symposium on Electronics and Telecommunications, Pages: 137-140, 13th International Symposium on Electronics and Telecommunications (ISETC), NOV 08-09, 2018, Timisoara, ROMANIA, ISSN: 2475-787X, ISBN: 978-1-5386-5925-0, Published: 2018;
133. Lup, P.S., Ivascu, L., Prosteian, G. Manipulation and Risk in The TV Commercial at Sweets for Childrens, INNOVATION MANAGEMENT AND EDUCATION EXCELLENCE THROUGH VISION 2020, VOLS I -XI, Pages: 858-868, 31st International-Business-Information-Management-Association Conference, APR 25-26, 2018, Milan, ITALY, ISBN: 978-0-9998551-0-2, Published: 2018;

134. Lupse, O.S., Chirila, C.B., Ciocarlie, H. Programming Concepts in the Silver Code Guide for Elders, 2018 IEEE 12TH INTERNATIONAL SYMPOSIUM ON APPLIED COMPUTATIONAL INTELLIGENCE AND INFORMATICS (SACI), Pages: 137-142, 12th IEEE International Symposium on Applied Computational Intelligence and Informatics (SACI), MAY 17-19, 2018, Timisoara, ROMANIA, ISBN: 978-1-5386-4640-3, Published: 2018;
135. Lupse, O.S., Chirila, C.B., Stoicu-Tivadar, L. Harnessing Ontologies to Improve Prescription in Pediatric Medicine, DECISION SUPPORT SYSTEMS AND EDUCATION: HELP AND SUPPORT IN HEALTHCARE, Book Series: Studies in Health Technology and Informatics, Volume: 255, Pages: 97-101, PubMed ID: 30306915, Special Topic Conference of the European-Federation-for-Medical-Informatics (EFMI STC), OCT 15-16, 2018, Zagreb, CROATIA, ISSN: 0926-9630, eISSN: 1879-8365, ISBN: 978-1-61499-921-8; 978-1-61499-920-1, Published: 2018;
136. Luputi, A.M.F., Mnerie, C.A., Duma, V.F. Experimental Setup for an Optical Micrometer with a Polygonal Mirror-based Laser Scanner, 2018 IEEE 12TH INTERNATIONAL SYMPOSIUM ON APPLIED COMPUTATIONAL INTELLIGENCE AND INFORMATICS (SACI), Pages: 589-592, 12th IEEE International Symposium on Applied Computational Intelligence and Informatics (SACI), MAY 17-19, 2018, Timisoara, ROMANIA, ISBN: 978-1-5386-4640-3, Published: 2018;
137. Magu, G.A., Kovaci, M. Images' Principal Component Analysis using Hyperanalytic Wavelet Packets, 2018 13TH INTERNATIONAL SYMPOSIUM ON ELECTRONICS AND TELECOMMUNICATIONS (ISETC), Book Series: International Symposium on Electronics and Telecommunications, Pages: 324-327, 13th International Symposium on Electronics and Telecommunications (ISETC), NOV 08-09, 2018, Timisoara, ROMANIA, ISSN: 2475-787X, ISBN: 978-1-5386-5925-0, Published: 2018;
138. Mahmut, E.E., Stoicu-Tivadar, V. Current Challenges in the Computer-Based Assessment of Speech Sound Disorders, 2018 IEEE 12TH INTERNATIONAL SYMPOSIUM ON APPLIED COMPUTATIONAL INTELLIGENCE AND INFORMATICS (SACI), Pages: 431-435, 12th IEEE International Symposium on Applied Computational Intelligence and Informatics (SACI), MAY 17-19, 2018, Timisoara, ROMANIA, ISBN: 978-1-5386-4640-3, Published: 2018;
139. Mahmut, E.E., Stoicu-Tivadar, V. A Speech Sound Disorder Screening System Database Structure, DECISION SUPPORT SYSTEMS AND EDUCATION: HELP AND SUPPORT IN HEALTHCARE, Book Series: Studies in Health Technology and Informatics, Volume: 255, Pages: 185-189, PubMed ID: 30306933, Special Topic Conference of the European-Federation-for-Medical-Informatics (EFMI STC), OCT 15-16, 2018, Zagreb, CROATIA, ISSN: 0926-9630, eISSN: 1879-8365, ISBN: 978-1-61499-921-8; 978-1-61499-920-1, Published: 2018;
140. Marcauteanu, C., Sinescu, C., Toader, M., Negrutiu, M.L., Mitroi, F.E., Stoica, E.T., Topala, F., Duma, V.F., Bradu, A., Podoleanu, A.G. Biomimetic Tizian "table tops" analyzed with swept source optical coherence tomography, SEVENTH INTERNATIONAL CONFERENCE ON LASERS IN MEDICINE, Book Series: Proceedings of SPIE, Volume: 10831, Article Number: UNSP 108310M, 7th Romanian-Society-for-Laser-in-Dentistry (SRLS) International Conference on Lasers in Medicine / 1st Congress of Laser in Dentistry, JUL 13-15, 2017, Timisoara, ROMANIA, ISSN: 0277-786X, eISSN: 1996-756X, ISBN: 978-1-5106-2288-3, Published: 2018;
141. Marin, A., Menyhardt, K., Marin, A.M., Nagy, R., Poenaru, M. Prototype Device for Mastoid Obliteration in Pediatric Cholesteatoma Patients, ACOUSTICS AND VIBRATION OF MECHANICAL STRUCTURES (AVMS-2017), Book Series: Springer Proceedings in Physics, Volume: 198, Pages: 157-163, 14th International Conference on Acoustics and Vibration of Mechanical Structures (AVMS), MAY 25-26, 2017, Timisoara, ROMANIA, ISSN: 0930-8989, eISSN: 1867-4941, ISBN: 978-3-319-69823-6; 978-3-319-69822-9, Published: 2018;
142. Marinca, V., Herisanu, N. Vibration of Nonlinear Nonlocal Elastic Column with Initial Imperfection, ACOUSTICS AND VIBRATION OF MECHANICAL STRUCTURES (AVMS-2017), Book Series: Springer Proceedings in Physics, Volume: 198, Pages: 49-56, 14th International Conference on Acoustics and Vibration of Mechanical Structures (AVMS), MAY 25-26, 2017, Timisoara, ROMANIA, ISSN: 0930-8989, eISSN: 1867-4941, ISBN: 978-3-319-69823-6; 978-3-319-69822-9, Published: 2018;
143. Marinca, V., Herisanu, N. Viscous Flow of an Incompressible Fluid over a Curved Stretching Surface, INTERNATIONAL CONFERENCE OF NUMERICAL ANALYSIS AND APPLIED MATHEMATICS (ICNAAM 2017), Book Series: AIP Conference Proceedings, Volume: 1978, Article Number: UNSP 310004-1, International Conference of Numerical Analysis and Applied Mathematics (ICNAAM), SEP 25-30, 2017, Thessaloniki, GREECE, ISSN: 0094-243X, ISBN: 978-0-7354-1690-1, Published: 2018;
144. Marinca, V., Herisanu, N. The nonlinear thermomechanical vibration of a functionally graded beam on Winkler-Pasternak foundation, INTERNATIONAL CONFERENCE ON ENGINEERING VIBRATION (ICOEV 2017), Book Series: MATEC Web of Conferences, Volume: 148, Article Number: UNSP 13004, International Conference on Engineering Vibration (ICoEV), SEP 04-07, 2017, Sofia, BULGARIA, ISSN: 2261-236X, Published: 2018;

145. Maris, S., Maris, S.A., Cojocariu, N., Humita, M. Using ICT support for STEM education in disadvantaged youth learning, 2018 13TH INTERNATIONAL SYMPOSIUM ON ELECTRONICS AND TELECOMMUNICATIONS (ISETC), Book Series: International Symposium on Electronics and Telecommunications, Pages: 355-358, 13th International Symposium on Electronics and Telecommunications (ISETC), NOV 08-09, 2018, Timisoara, ROMANIA, ISSN: 2475-787X, ISBN: 978-1-5386-5925-0, Published: 2018;
146. Maroiu, A.C., Rominu, M., Sinescu, C., Negrutiu, M.L., Topala, F., Duma, V.F., Bradu, A., Podoleanu, A.G. Optoelectronic evaluation of indirect dental veneers interfaces, SEVENTH INTERNATIONAL CONFERENCE ON LASERS IN MEDICINE, Book Series: Proceedings of SPIE, Volume: 10831, Article Number: UNSP 1083100, 7th Romanian-Society-for-Laser-in-Dentistry (SRLS) International Conference on Lasers in Medicine / 1st Congress of Laser in Dentistry, JUL 13-15, 2017, Timisoara, ROMANIA, ISSN: 0277-786X, eISSN: 1996-756X, ISBN: 978-1-5106-2288-3, Published: 2018;
147. Marsavina, L., Pop, O., Linul, E. Mixed mode fracture toughness of particleboard, IGF WORKSHOP FRACTURE AND STRUCTURAL INTEGRITY, Book Series: Procedia Structural Integrity, Volume: 9, Pages: 47-54, IGF Workshop on Fracture and Structural Integrity - Ten Years of Fracture and Structural Integrity, JUN 04-06, 2018, Cassino, ITALY, ISSN: 2452-3216, Published: 2018;
148. Marsavina, L., Pop, O., Pepelan, R. Mark tracking technique for experimental determination of fracture parameters, ECF22 - LOADING AND ENVIRONMENTAL EFFECTS ON STRUCTURAL INTEGRITY, Book Series: Procedia Structural Integrity, Volume: 13, Pages: 1867-1872, 22nd European Conference on Fracture (ECF) - Loading and Environmental Effects on Structural Integrity, AUG 26-31, 2018, Belgrade, SERBIA, ISSN: 2452-3216, Published: 2018;
149. Mateas, M., Argesanu, V., Mateas, I., Farkas, A. Considerations about the Use of Baropodometry in Lay Detection, INTERNATIONAL CONFERENCE MULTIDISCIPLINARY PERSPECTIVES IN THE QUASI-COERCIVE TREATMENT OF OFFENDERS (SPECTO), 7TH EDITION - GROUPS WITH SPECIAL NEEDS IN COMMUNITY MEASURES, Pages: 110-115, 7th International Conference on Multidisciplinary Perspectives in the Quasi-Coercive Treatment of Offenders (SPECTO) - Groups with Special Needs in Community Measures, SEP 13-14, 2018, Timisoara, ROMANIA, ISBN: 978-88-85813-25-0, Published: 2018;
150. Mateas, M., Mateas, I. New Methods to Evaluate the Efficiency of Custodial Sentences, INTERNATIONAL CONFERENCE MULTIDISCIPLINARY PERSPECTIVES IN THE QUASI-COERCIVE TREATMENT OF OFFENDERS (SPECTO), 7TH EDITION - GROUPS WITH SPECIAL NEEDS IN COMMUNITY MEASURES, Pages: 116-121, 7th International Conference on Multidisciplinary Perspectives in the Quasi-Coercive Treatment of Offenders (SPECTO) - Groups with Special Needs in Community Measures, SEP 13-14, 2018, Timisoara, ROMANIA, ISBN: 978-88-85813-25-0, Published: 2018;
151. Mateas, M., Moldovan, C., Gruescu, C.M., Kis, A., Lovasz, E.C. Novel rehabilitation system for the lower limb, 8TH INTERNATIONAL CONFERENCE ON ADVANCED CONCEPTS IN MECHANICAL ENGINEERING, Book Series: IOP Conference Series-Materials Science and Engineering, Volume: 444, Article Number: 052021, 8th International Conference on Advanced Concepts in Mechanical Engineering (ACME), JUN 07-08, 2018, Iasi, ROMANIA, ISSN: 1757-8981, Published: 2018;
152. Mateescu, A., Paraschiva, G.A., Ivascu, L., Draghici, A. A Study of the Behavior Adaptation Dimension the Case of a Multicultural Virtual Organization, INNOVATION MANAGEMENT AND EDUCATION EXCELLENCE THROUGH VISION 2020, VOLS I -XI, Pages: 6467-6489, 31st International-Business-Information-Management-Association Conference, APR 25-26, 2018, Milan, ITALY, ISBN: 978-0-9998551-0-2, Published: 2018;
153. Mateoiu, A.M., Korodi, A. OPC-UA Based Small-Scale Monitoring and Control Solution for Android Devices Case Study for Water Treatment Plants, CONFERENCE PROCEEDINGS OF 2018 4TH INTERNATIONAL CONFERENCE ON CONTROL, AUTOMATION AND ROBOTICS (ICCAR), Pages: 190-195, 4th International Conference on Control, Automation and Robotics (ICCAR), APR 20-23, 2018, Auckland, NEW ZEALAND, ISBN: 978-1-5386-6338-7, Published: 2018;
154. Mercioni, M.A., Holban, S. Evaluating hierarchical and non-hierarchical grouping for develop a smart system, 2018 13TH INTERNATIONAL SYMPOSIUM ON ELECTRONICS AND TELECOMMUNICATIONS (ISETC), Book Series: International Symposium on Electronics and Telecommunications, Pages: 114-117, 13th International Symposium on Electronics and Telecommunications (ISETC), NOV 08-09, 2018, Timisoara, ROMANIA, ISSN: 2475-787X, ISBN: 978-1-5386-5925-0, Published: 2018;



155. Mercioni, M.A., Holban, S. The recognition of the architectural style using Data Mining techniques, 2018 IEEE 12TH INTERNATIONAL SYMPOSIUM ON APPLIED COMPUTATIONAL INTELLIGENCE AND INFORMATICS (SACI), Pages: 331-337, 12th IEEE International Symposium on Applied Computational Intelligence and Informatics (SACI), MAY 17-19, 2018, Timisoara, ROMANIA, ISBN: 978-1-5386-4640-3, Published: 2018;
156. Miclea, R.C., Silea, I., Sandru, F. Digital Sunshade Using Head-up Display, SOFT COMPUTING APPLICATIONS, SOFA 2016, VOL 1, Book Series: Advances in Intelligent Systems and Computing, Volume: 633, Pages: 3-11, 7th International Workshop on Soft Computing Applications (SOFA), AUG 24-26, 2016, Arad, ROMANIA, ISSN: 2194-5357, eISSN: 2194-5365, ISBN: 978-3-319-62521-8, Published: 2018;
157. Miclea, S., Pugna, A. FROM CUSTOMER NEEDS TO CUSTOMER SATISFACTION: THE FAST WAY, PERFORMANCE MANAGEMENT OR MANAGEMENT PERFORMANCE?, Book Series: Review of Management and Economic Engineering International Management Conference, Pages: 585-590, 6th Review of Management and Economic Engineering International Management Conference, SEP 20-22, 2018, Cluj Napoca, ROMANIA, ISSN: 2247-8639, Published: 2018;
158. Miclea, S., Pugna, A., Negrea, R., Potra, S. USING A REFINED ATTRACTIVE QUALITY MODEL FOR ASSESSING STUDENTS' REQUIREMENTS FOR A NEW UNIVERSITY ONLINE APPLICATION, 12TH INTERNATIONAL TECHNOLOGY, EDUCATION AND DEVELOPMENT CONFERENCE (INTED), Book Series: INTED Proceedings, Pages: 5153-5161, 12th International Technology, Education and Development Conference (INTED), MAR 05-07, 2018, Valencia, SPAIN, ISSN: 2340-1079, ISBN: 978-84-697-9480-7, Published: 2018;
159. Mihaescu, V., Draghici, A., Ivascu, L. A STUDY ON CREATIVE ENTREPRENEURS TRAINING NEEDS ASSESSMENT, PERFORMANCE MANAGEMENT OR MANAGEMENT PERFORMANCE?, Book Series: Review of Management and Economic Engineering International Management Conference, Pages: 454-465, 6th Review of Management and Economic Engineering International Management Conference, SEP 20-22, 2018, Cluj Napoca, ROMANIA, ISSN: 2247-8639, Published: 2018;
160. Mihajlov, D., Prascevic, M., Herisanu, N. Selection of Measurement Strategy for the Assessment of Long-Term Environmental Noise Indicators Using Multi-criteria Optimization, ACOUSTICS AND VIBRATION OF MECHANICAL STRUCTURES (AVMS-2017), Book Series: Springer Proceedings in Physics, Volume: 198, Pages: 77-82, 14th International Conference on Acoustics and Vibration of Mechanical Structures (AVMS), MAY 25-26, 2017, Timisoara, ROMANIA, ISSN: 0930-8989, eISSN: 1867-4941, ISBN: 978-3-319-69823-6; 978-3-319-69822-9, Published: 2018;
161. Mihit, C.L., Lapadat, M. Discrete Criteria for the Uniform (h, k)-splitting of Skew-evolution Semiflows, INTERNATIONAL CONFERENCE OF NUMERICAL ANALYSIS AND APPLIED MATHEMATICS (ICNAAM 2017), Book Series: AIP Conference Proceedings, Volume: 1978, Article Number: UNSP 390011-1, International Conference of Numerical Analysis and Applied Mathematics (ICNAAM), SEP 25-30, 2017, Thessaloniki, GREECE, ISSN: 0094-243X, ISBN: 978-0-7354-1690-1, Published: 2018;
162. Mirea, A., Albu, A. Acquisition of Physical Data in an Automated System for Monitoring Medication Stocks, 2018 IEEE 12TH INTERNATIONAL SYMPOSIUM ON APPLIED COMPUTATIONAL INTELLIGENCE AND INFORMATICS (SACI), Pages: 179-182, 12th IEEE International Symposium on Applied Computational Intelligence and Informatics (SACI), MAY 17-19, 2018, Timisoara, ROMANIA, ISBN: 978-1-5386-4640-3, Published: 2018;
163. Mirea, A., Albu, A. Automated System for Medication Stocks Management, 2018 22ND INTERNATIONAL CONFERENCE ON SYSTEM THEORY, CONTROL AND COMPUTING (ICSTCC), Book Series: International Conference on System Theory Control and Computing, Pages: 529-534, 22nd International Conference on System Theory, Control and Computing (ICSTCC), OCT 10-12, 2018, Sinaia, ROMANIA, ISSN: 2372-1618, ISBN: 978-1-5386-4444-7, Published: 2018;
164. Mischie, S. On the Development of Bluetooth Low Energy Devices, 2018 12TH INTERNATIONAL CONFERENCE ON COMMUNICATIONS (COMM), Book Series: IEEE International Conference on Communications, Pages: 339-344, 12th IEEE International Conference on Communications (COMM), JUN 14-16, 2018, Bucharest, ROMANIA, ISSN: 1550-3607, ISBN: 978-1-5386-2350-3, Published: 2018;
165. Mischie, S., Matiu-lovan, L., Gasparesc, G. Implementation of Google Assistant on Raspberry Pi, 2018 13TH INTERNATIONAL SYMPOSIUM ON ELECTRONICS AND TELECOMMUNICATIONS (ISETC), Book Series: International Symposium on Electronics and Telecommunications, Pages: 74-77, 13th International Symposium on Electronics and Telecommunications (ISETC), NOV 08-09, 2018, Timisoara, ROMANIA, ISSN: 2475-787X, ISBN: 978-1-5386-5925-0, Published: 2018;

166. Mitroi, F.E., Sinescu, C., Marcauteanu, C., Muntean, D., Negrutiu, M.L., Stoica, E.T., Topala, F., Stan, A., Vaduva, A., Duma, V.F. Confocal laser scanning microscopy versus digital microscopy in the analysis of the marginal adaptation of Tizian overlays, SEVENTH INTERNATIONAL CONFERENCE ON LASERS IN MEDICINE, Book Series: Proceedings of SPIE, Volume: 10831, Article Number: UNSP 108310N, 7th Romanian-Society-for-Laser-in-Dentistry (SRLS) International Conference on Lasers in Medicine / 1st Congress of Laser in Dentistry, JUL 13-15, 2017, Timisoara, ROMANIA, ISSN: 0277-786X, eISSN: 1996-756X, ISBN: 978-1-5106-2288-3, Published: 2018;
167. Mocan, A., Draghici, A. Participatory ergonomics training for a warehouse environment-a process solution, OCCUPATIONAL SAFETY AND HYGIENE VI, Pages: 19-22, 6th International Symposium on Occupational Safety and Hygiene (SHO), MAR 26-27, 2018, Guimaraes, PORTUGAL, ISBN: 978-1-351-00888-4; 978-1-138-54203-7, Published: 2018;
168. Mocofan, M., Ciuclea, C. Need of Open Education Resources in the Students Opinion, ELEARNING CHALLENGES AND NEW HORIZONS, VOL 4, Book Series: eLearning and Software for Education, Pages: 357-362, 14th International Scientific Conference on eLearning and Software for Education - eLearning Challenges and New Horizons, APR 19-20, 2018, Bucharest, ROMANIA, ISSN: 2066-026X, Published: 2018;
169. Molnar, L., Gontean, A. Hardware Difficulties and Improvements for High Pressure Fuel Pump Solenoid Valve Noise Cancellation, 2018 IEEE 24TH INTERNATIONAL SYMPOSIUM FOR DESIGN AND TECHNOLOGY IN ELECTRONIC PACKAGING (SIITME), Book Series: International Symposium for Design and Technology in Electronic Packaging, Pages: 84-89, 24th IEEE International Symposium on Design and Technology in Electronic Packaging (SIITME), OCT 25-28, 2018, Iasi, ROMANIA, ISSN: 2641-287X, ISBN: 978-1-5386-5577-1, Published: 2018;
170. Molnar, L., Kotlar, A., Lica, S. High Power Switch using IGBT and GaN MOSFET A solution proposal, 2018 IEEE 24TH INTERNATIONAL SYMPOSIUM FOR DESIGN AND TECHNOLOGY IN ELECTRONIC PACKAGING (SIITME), Book Series: International Symposium for Design and Technology in Electronic Packaging, Pages: 43-48, 24th IEEE International Symposium on Design and Technology in Electronic Packaging (SIITME), OCT 25-28, 2018, Iasi, ROMANIA, ISSN: 2641-287X, ISBN: 978-1-5386-5577-1, Published: 2018;
171. Molnar, L., Luca, O., Gontean, A. Simulation Method to Evaluate Thermal Runaway of MOSFETs, 2018 41ST INTERNATIONAL SPRING SEMINAR ON ELECTRONICS TECHNOLOGY (ISSE), Book Series: International Spring Seminar on Electronics Technology ISSE, 41st International Spring Seminar on Electronics Technology (ISSE), MAY 16-20, 2018, Zlatibor, SERBIA, ISSN: 2161-2536, ISBN: 978-1-5386-5731-7; 978-3-319-73847-5, Published: 2018;
172. Muntean, G.A., Prostean, G. Hazard Analyses and Risk Assessment (HARA) Interface with Design for Six Sigma (DFSS) in Automotive Industry, INNOVATION MANAGEMENT AND EDUCATION EXCELLENCE THROUGH VISION 2020, VOLS I -XI, Pages: 5530-5536, 31st International-Business-Information-Management-Association Conference, APR 25-26, 2018, Milan, ITALY, ISBN: 978-0-9998551-0-2, Published: 2018;
173. Munteanu, D., Popovici, A. Capacitive Touch Sensor Used In Visually Impaired Aid Equipments, 2018 13TH INTERNATIONAL SYMPOSIUM ON ELECTRONICS AND TELECOMMUNICATIONS (ISETC), Book Series: International Symposium on Electronics and Telecommunications, Pages: 70-73, 13th International Symposium on Electronics and Telecommunications (ISETC), NOV 08-09, 2018, Timisoara, ROMANIA, ISSN: 2475-787X, ISBN: 978-1-5386-5925-0, Published: 2018;
174. Muresan, T., Papazian, P. IEEE 1451 compliant magnetic rotary transducer with energy feedback channel, 2018 13TH INTERNATIONAL SYMPOSIUM ON ELECTRONICS AND TELECOMMUNICATIONS (ISETC), Book Series: International Symposium on Electronics and Telecommunications, Pages: 125-128, 13th International Symposium on Electronics and Telecommunications (ISETC), NOV 08-09, 2018, Timisoara, ROMANIA, ISSN: 2475-787X, ISBN: 978-1-5386-5925-0, Published: 2018;
175. Nafornta, C., Buehler, S., Isar, A., Otesteanu, M., Nafornta, I., Campeanu, A., Monnerat, M., Bauer, F., Ramonjoan, A., Reche, M., Garcia, D., Vasile, V.C., Borda, M., Tarniceriu, D. Romania Monitoring Station Network to Support EGNOS Services in Eastern Europe, 2018 13TH INTERNATIONAL SYMPOSIUM ON ELECTRONICS AND TELECOMMUNICATIONS (ISETC), Book Series: International Symposium on Electronics and Telecommunications, Pages: 153-160, 13th International Symposium on Electronics and Telecommunications (ISETC), NOV 08-09, 2018, Timisoara, ROMANIA, ISSN: 2475-787X, ISBN: 978-1-5386-5925-0, Published: 2018;
176. Nafornta, C., Isar, A., Dehelean, T. Multilook SAR Image Enhancement using the Dual Tree Complex Wavelet Transform, 2018 12TH INTERNATIONAL CONFERENCE ON COMMUNICATIONS (COMM), Book Series: IEEE International Conference on Communications, Pages: 151-156, 12th IEEE International Conference on Communications (COMM), JUN 14-16, 2018, Bucharest, ROMANIA, ISSN: 1550-3607, ISBN: 978-1-5386-2350-3, Published: 2018;

177. Nafornta, C., Isar, A., Otesteanu, M., Nafornta, I., Campeanu, A. The Evaluation of the Effect of NLOS Multipath Propagation in Case of GNSS Receivers, 2018 13TH INTERNATIONAL SYMPOSIUM ON ELECTRONICS AND TELECOMMUNICATIONS (ISETC), Book Series: International Symposium on Electronics and Telecommunications, Pages: 328-331, 13th International Symposium on Electronics and Telecommunications (ISETC), NOV 08-09, 2018, Timisoara, ROMANIA, ISSN: 2475-787X, ISBN: 978-1-5386-5925-0, Published: 2018;
178. Nagy, R., Maruta, R.S., Menyhardt, K. Active Vibration Control of Test Equipment Through Feedback Algorithm, ACOUSTICS AND VIBRATION OF MECHANICAL STRUCTURES (AVMS-2017), Book Series: Springer Proceedings in Physics, Volume: 198, Pages: 247-255, 14th International Conference on Acoustics and Vibration of Mechanical Structures (AVMS), MAY 25-26, 2017, Timisoara, ROMANIA, ISSN: 0930-8989, eISSN: 1867-4941, ISBN: 978-3-319-69823-6; 978-3-319-69822-9, Published: 2018;
179. Nicola, S., Lupse, O.S., Stoicu-Tivadar, L. Novel Gesture Interaction Using Leap Motion in 3D Applications, 2018 IEEE 12TH INTERNATIONAL SYMPOSIUM ON APPLIED COMPUTATIONAL INTELLIGENCE AND INFORMATICS (SACI), Pages: 113-117, 12th IEEE International Symposium on Applied Computational Intelligence and Informatics (SACI), MAY 17-19, 2018, Timisoara, ROMANIA, ISBN: 978-1-5386-4640-3, Published: 2018;
180. Nicola, S., Stoicu-Tivadar, L. Mixed Reality Supporting Modern Medical Education, DECISION SUPPORT SYSTEMS AND EDUCATION: HELP AND SUPPORT IN HEALTHCARE, Book Series: Studies in Health Technology and Informatics, Volume: 255, Pages: 242-246, PubMed ID: 30306945, Special Topic Conference of the European-Federation-for-Medical-Informatics (EFMI STC), OCT 15-16, 2018, Zagreb, CROATIA, ISSN: 0926-9630, eISSN: 1879-8365, ISBN: 978-1-61499-921-8; 978-1-61499-920-1, Published: 2018;
181. Nicola, S., Stoicu-Tivadar, L., Patrascoiu, A. VR for Education in Information and Tehnology: application for Bubble Sort, 2018 13TH INTERNATIONAL SYMPOSIUM ON ELECTRONICS AND TELECOMMUNICATIONS (ISETC), Book Series: International Symposium on Electronics and Telecommunications, Pages: 343-346, 13th International Symposium on Electronics and Telecommunications (ISETC), NOV 08-09, 2018, Timisoara, ROMANIA, ISSN: 2475-787X, ISBN: 978-1-5386-5925-0, Published: 2018;
182. Nicolae, A., Korodi, A., Silea, I. Modular and model-driven configurable approach for a centralized home-security system, 2018 IEEE 12TH INTERNATIONAL SYMPOSIUM ON APPLIED COMPUTATIONAL INTELLIGENCE AND INFORMATICS (SACI), Pages: 467-472, 12th IEEE International Symposium on Applied Computational Intelligence and Informatics (SACI), MAY 17-19, 2018, Timisoara, ROMANIA, ISBN: 978-1-5386-4640-3, Published: 2018;
183. Nicolae, A., Korodi, A. Node-Red and OPC UA Based Lightweight and Low-Cost Historian with Application in the Water Industry, 2018 IEEE 16TH INTERNATIONAL CONFERENCE ON INDUSTRIAL INFORMATICS (INDIN), Book Series: IEEE International Conference on Industrial Informatics INDIN, Pages: 1012-1017, 16th IEEE International Conference on Industrial Informatics (INDIN), JUL 18-20, 2018, Porto, PORTUGAL, ISSN: 1935-4576, ISBN: 978-1-5386-4829-2, Published: 2018;
184. Nicolau, I., Anghel, A.A., Mohora, I. TEAMWORK STRATEGIES AND METHODS TO IMPROVE DRAWING SKILLS FOR STUDENTS (CASE STUDY: UNIVERSITY OF ARCHITECTURE AND URBANISM, TIMISOARA, INTERIOR DESIGN DEPARTMENT), 5TH INTERNATIONAL CONFERENCE ON EDUCATION AND SOCIAL SCIENCES (INTCESS 2018), Pages: 524-533, 5th International Conference on Education and Social Sciences (INTCESS), FEB 05-07, 2018, Istanbul, TURKEY, ISBN: 978-605-82433-2-3, Published: 2018;
185. Nicolau, I., Mohora, I., Anghel, A.A. GREENERY IN MINERAL AREAS, HISTORY AND CASE STUDY OF INTERIOR COURTYARDS TIMISOARA, 5TH INTERNATIONAL CONFERENCE ON EDUCATION AND SOCIAL SCIENCES (INTCESS 2018), Pages: 534-542, 5th International Conference on Education and Social Sciences (INTCESS), FEB 05-07, 2018, Istanbul, TURKEY, ISBN: 978-605-82433-2-3, Published: 2018;
186. Nimara, S., Mereu, A., Crisan-Vida, M., Bogdan, R. Portable device for remote control of a vehicle, 2018 26TH TELECOMMUNICATIONS FORUM (TELFOR), Pages: 281-284, 26th Telecommunications Forum (TELFOR), NOV 20-21, 2018, Belgrade, SERBIA, ISBN: 978-1-5386-7171-9, Published: 2018;
187. Niraula, M., Maharjan, L., Fahimi, B., Kiani, M., Boldea, I. Variable Stator Frequency Control of Stand-Alone DFIG with Diode Rectified Output, 2018 5TH INTERNATIONAL SYMPOSIUM ON ENVIRONMENT-FRIENDLY ENERGIES AND APPLICATIONS (EFEA), 5th International Symposium on Environment-Friendly Energies and Applications (EFEA), SEP 24-26, 2018, Rome, ITALY, ISBN: 978-1-5386-5517-7, Published: 2018;
188. Nyaguly, E., Simoiu, D., Crastiu, I., Pop-Gozman, C., Vladaia, D., Bereteu, L. Determination of the Thickness of the Paint Coating of Metal Surfaces by the Impulse Technique, 2018 IEEE 16TH INTERNATIONAL SYMPOSIUM ON INTELLIGENT SYSTEMS AND INFORMATICS (SISY 2018), Book Series: International Symposium on Intelligent Systems and Informatics, Pages: 133-136, IEEE 16th International Symposium on Intelligent Systems and Informatics (SISY), SEP 13-15, 2018, Subotica, SERBIA, ISSN: 1949-047X, ISBN: 978-1-5386-6841-2, Published: 2018;

189. Onchis, D.M., Zappala, S., Real, P., Istin, C. Numerical stability of spline-based Gabor-like systems, 2018 26TH EUROPEAN SIGNAL PROCESSING CONFERENCE (EUSIPCO), Book Series: European Signal Processing Conference, Pages: 1337-1341, PubMed ID: 30555797, European Signal Processing Conference (EUSIPCO), AUG 03-07, 2018, Rome, ITALY, ISSN: 2076-1465, ISBN: 978-90-827970-1-5, Published: 2018;
190. Ordean, M.N., Grosu, V.T., Neamtu (Popescu), A., Stanescu, P., Traistaru, M. PROCEDURES FOR RECOVER CIPHOSIS -COMPARISON BETWEEN NEUROMUSCULAR ELECTROSTIMULATION AND AUDITIVE FEEDBACK-, ERD 2017 - EDUCATION, REFLECTION, DEVELOPMENT, FIFTH EDITION, Book Series: European Proceedings of Social and Behavioural Sciences, Volume: 41, Pages: 692-698, 5th Conference on Education, Reflection, Development (ERD), JUL 07-08, 2017, Cluj Napoca, ROMANIA, ISSN: 2357-1330; Published: 2018;
191. Orzen, S.N., Stratulat, M. Performance Queues for Fault Tolerant Sessions, 2018 13TH INTERNATIONAL SYMPOSIUM ON ELECTRONICS AND TELECOMMUNICATIONS (ISETC), Book Series: International Symposium on Electronics and Telecommunications, Pages: 203-206, 13th International Symposium on Electronics and Telecommunications (ISETC), NOV 08-09, 2018, Timisoara, ROMANIA, ISSN: 2475-787X, ISBN: 978-1-5386-5925-0, Published: 2018;
192. Panoiu, M., Panoiu, C., Ghiormez, L. Neuro-fuzzy modeling and prediction of current total harmonic distortion for high power nonlinear loads, 2018 INNOVATIONS IN INTELLIGENT SYSTEMS AND APPLICATIONS (INISTA), IEEE (SMC) International Conference on Innovations in Intelligent Systems and Applications (INISTA), JUL 03-05, 2018, Thessaloniki, GREECE, ISBN: 978-1-5386-5150-6, Published: 2018;
193. Paraschiva, G.A., Draghici, A. ASSESSMENT OF THE PROFESSIONAL AND MANAGEMENT COMPETENCES AS PART OF PROJECT MEMORY, PROCEEDINGS OF THE 15TH INTERNATIONAL CONFERENCE EFFICIENCY AND RESPONSIBILITY IN EDUCATION 2018 (ERIE), Book Series: Efficiency and Responsibility in Education ..., Pages: 272-280, 15th International Conference on Efficiency and Responsibility in Education (ERIE), JUN 06-08, 2018, Prague, CZECH REPUBLIC, ISSN: 2336-744X, ISBN: 978-80-213-2858-7, Published: 2018;
194. Pascu, D., Tamasila, M., Diaconescu, A., Prostean, G. Performing Multi-Criteria Analysis to Solve Municipal Solid Waste Management Problems, INNOVATION MANAGEMENT AND EDUCATION EXCELLENCE THROUGH VISION 2020, VOLS IV -VI, Pages: 2289-2298, 31st International-Business-Information-Management-Association Conference, APR 25-26, 2018, Milan, ITALY, ISBN: 978-0-9998551-0-2, Published: 2018;
195. Paun, A., Vinga, C.M., Frigura-Iliasa, F.M., Vatau, D., Cazacu, E., Petrescu, L. Study about the Active Power and Energy Losses of a 400V 57 kW Asynchronous Motor, PROCEEDINGS OF THE 2018 19TH INTERNATIONAL SCIENTIFIC CONFERENCE ON ELECTRIC POWER ENGINEERING (EPE), Book Series: International Scientific Conference on Electric Power Engineering, 19th International Scientific Conference on Electric Power Engineering (EPE), MAY 16-18, 2018, Brno, CZECH REPUBLIC, ISSN: 2376-5623, ISBN: 978-1-5386-4612-0, Published: 2018;
196. Petrenko, V.I., Nagornyj, A.V., Gapon, I.V., Vekas, L., Garamus, V.M., Almasy, L., Feoktystov, A.V., Avdeev, M.V. Magnetic Fluids: Structural Aspects by Scattering Techniques, MODERN PROBLEMS OF MOLECULAR PHYSICS, Book Series: Springer Proceedings in Physics, Volume: 197, Pages: 205-226, 7th Conference of the Physics of Liquid Matter - Modern Problems (PLMMP), MAY 27-30, 2016, Kyiv, UKRAINE, ISSN: 0930-8989, eISSN: 1867-4941, ISBN: 978-3-319-61109-9; 978-3-319-61108-2, Published: 2018;
197. Pop-Calimanu, I.M., Lica, S., Lascu, D., Renken, F. A Novel Hybrid Buck-L Converter, 2018 20TH EUROPEAN CONFERENCE ON POWER ELECTRONICS AND APPLICATIONS (EPE'18 ECCE EUROPE), Book Series: European Conference on Power Electronics and Applications, 20th European Conference on Power Electronics and Applications (EPE ECCE Europe), SEP 17-21, 2018, Riga, LATVIA, ISSN: 2325-0313, ISBN: 978-9-0758-1528-3, Published: 2018;
198. Pop-Calimanu, I.M., Lica, S., Lascu, D., Renken, F., Gurbina, M., Mirsu, R. A Novel Hybrid Step-Down DC-DC Converter, 2018 IEEE 18TH INTERNATIONAL POWER ELECTRONICS AND MOTION CONTROL CONFERENCE (PEMC), Book Series: IEEE International Power Electronics and Motion Control Conference IPEMC, Pages: 34-39, 18th IEEE International Power Electronics and Motion Control Conference (IEEE PEMC), AUG 26-30, 2018, Budapest, HUNGARY, ISBN: 978-1-5386-4198-9, Published: 2018;
199. Pop-Calimanu, I.M., Lica, S., Renken, F., Mirsu, R., Simion, G., Lie, I. A Comparison Between Single-Phase and Two-Phase Hybrid Boost-L Converter, 2018 13TH INTERNATIONAL SYMPOSIUM ON ELECTRONICS AND TELECOMMUNICATIONS (ISETC), Book Series: International Symposium on Electronics and Telecommunications, Pages: 129-132, 13th International Symposium on Electronics and Telecommunications (ISETC), NOV 08-09, 2018, Timisoara, ROMANIA, ISSN: 2475-787X, ISBN: 978-1-5386-5925-0, Published: 2018;
200. Popa, C.A. Complex-Valued Stacked Denoising Autoencoders, ADVANCES IN NEURAL NETWORKS - ISNN 2018, Book Series: Lecture Notes in Computer Science, Volume: 10878, Pages: 64-71, 15th International Symposium on Neural Networks (ISNN), JUN 25-28, 2018, Minsk, BELARUS, ISSN: 0302-9743, eISSN: 1611-3349, ISBN: 978-3-319-92537-0; 978-3-319-92536-3, Published: 2018;

201. Popa, C.A. Complex-Valued Deep Belief Networks, ADVANCES IN NEURAL NETWORKS – ISSN 2018, Book Series: Lecture Notes in Computer Science, Volume: 10878, Pages: 72–78, 15th International Symposium on Neural Networks (ISNN), JUN 25–28, 2018, Minsk, BELARUS, ISSN: 0302-9743, eISSN: 1611-3349, ISBN: 978-3-319-92537-0; 978-3-319-92536-3, Published: 2018;
202. Popa, C.A., Cernazanu–Glavan, C. Fourier Transform–Based Image Classification Using Complex–Valued Convolutional Neural Networks, ADVANCES IN NEURAL NETWORKS – ISSN 2018, Book Series: Lecture Notes in Computer Science, Volume: 10878, Pages: 300–309, 15th International Symposium on Neural Networks (ISNN), JUN 25–28, 2018, Minsk, BELARUS, ISSN: 0302-9743, eISSN: 1611-3349, ISBN: 978-3-319-92537-0; 978-3-319-92536-3, Published: 2018;
203. Popa, C.A. Matrix–Valued Bidirectional Associative Memories, SOFT COMPUTING APPLICATIONS, SOFA 2016, VOL 2, Book Series: Advances in Intelligent Systems and Computing, Volume: 634, Pages: 36–44, 7th International Workshop on Soft Computing Applications (SOFA), AUG 24–26, 2016, Arad, ROMANIA, ISSN: 2194-5357, eISSN: 2194-5365, ISBN: 978-3-319-62524-9, Published: 2018;
204. Popa, C.A. Enhanced Gradient Descent Algorithms for Quaternion–Valued Neural Networks, SOFT COMPUTING APPLICATIONS, SOFA 2016, VOL 2, Book Series: Advances in Intelligent Systems and Computing, Volume: 634, Pages: 45–53, 7th International Workshop on Soft Computing Applications (SOFA), AUG 24–26, 2016, Arad, ROMANIA, ISSN: 2194-5357, eISSN: 2194-5365, ISBN: 978-3-319-62524-9, Published: 2018;
205. Popescu, A., Frigura–Iliasa, F.M., Vatau, D., Frigura–Iliasa, M. Laboratory System Automation for Testing the Influence of 20 kV Power Equipment on Closed Low Voltage or Telecommunication Lines, 2018 IEEE 16TH WORLD SYMPOSIUM ON APPLIED MACHINE INTELLIGENCE AND INFORMATICS (SAMI 2018): DEDICATED TO THE MEMORY OF PIONEER OF ROBOTICS ANTAL (TONY) K. BEJCZY, Pages: 103–107, IEEE 16th World Symposium on Applied Machine Intelligence and Informatics (SAMI) Dedicated to the Memory of Pioneer of Robotics Antal (Tony) K. Bejczy, FEB 07–10, 2018, Kosice, SLOVAKIA, ISBN: 978-1-5386-4772-1, Published: 2018;
206. Popescu, A., Frigura–Iliasa, M., Vatau, D., Frigura–Iliasa, F.M., Dolga, L., Filipescu, H.E. An Original Computational Method for Assessing Active Losses Inside Asynchronous Motors, 2018 IEEE INTERNATIONAL CONFERENCE ON ENVIRONMENT AND ELECTRICAL ENGINEERING AND 2018 IEEE INDUSTRIAL AND COMMERCIAL POWER SYSTEMS EUROPE (EEEIC / I&CPS EUROPE), IEEE International Conference on Environment and Electrical Engineering / IEEE Industrial and Commercial Power Systems Europe (EEEIC / I&CPS Europe), JUN 12–15, 2018, Palermo, ITALY, ISBN: 978-1-5386-5186-5, Published: 2018;
207. Porojan, L., Savencu, C., Bolos, A., Rusu, L., Porojan, S. Mechanical approach of metal–ceramic crowns obtained with laser–based additive manufacturing methods, SEVENTH INTERNATIONAL CONFERENCE ON LASERS IN MEDICINE, Book Series: Proceedings of SPIE, Volume: 10831, Article Number: UNSP 1083107, 7th Romanian–Society–for–Laser–in–Dentistry (SRLS) International Conference on Lasers in Medicine / 1st Congress of Laser in Dentistry, JUL 13–15, 2017, Timisoara, ROMANIA, ISSN: 0277-786X, eISSN: 1996-756X, ISBN: 978-1-5106-2288-3, Published: 2018;
208. Precup, R.E., Teban, T.A., Petriu, E.M., Albu, A., Mituletu, I.C. Structure and Evolving Fuzzy Models for Prosthetic Hand Myoelectric–based Control Systems, 2018 26TH MEDITERRANEAN CONFERENCE ON CONTROL AND AUTOMATION (MED), Book Series: Mediterranean Conference on Control and Automation, Pages: 625–630, 26th Mediterranean Conference on Control and Automation (MED), JUN 19–22, 2018, Zadar, CROATIA, ISSN: 2325-369X, ISBN: 978-1-5386-7890-9, Published: 2018;
209. Prosteian, G., Vasar, C., Badea, A. Logistics Scenario for Wind Turbine Assembly Based on ERP, SOFT COMPUTING APPLICATIONS, SOFA 2016, VOL 2, Book Series: Advances in Intelligent Systems and Computing, Volume: 634, Pages: 194–200, 7th International Workshop on Soft Computing Applications (SOFA), AUG 24–26, 2016, Arad, ROMANIA, ISSN: 2194-5357, eISSN: 2194-5365, ISBN: 978-3-319-62524-9, Published: 2018;
210. Pungila, C., Galis, D., Negru, V. Optimizing Pattern–Matching for Memory–Efficient Heterogeneous DNA Processing in Bioinformatics, 2018 IEEE 12TH INTERNATIONAL SYMPOSIUM ON APPLIED COMPUTATIONAL INTELLIGENCE AND INFORMATICS (SACI), Pages: 455–460, 12th IEEE International Symposium on Applied Computational Intelligence and Informatics (SACI), MAY 17–19, 2018, Timisoara, ROMANIA, 978-1-5386-4640-3, Published: 2018;
211. Radac, M.B., Precup, R.E., Hedrea, E.L., Mituletu, I.C. Data–Driven Model–Free Model–Reference Nonlinear Virtual State–Feedback Control from Input–Output Data, 2018 26TH MEDITERRANEAN CONFERENCE ON CONTROL AND AUTOMATION (MED), Book Series: Mediterranean Conference on Control and Automation, Pages: 332–338, 26th Mediterranean Conference on Control and Automation (MED), JUN 19–22, 2018, Zadar, CROATIA, ISSN: 2325-369X, ISBN: 978-1-5386-7890-9, Published: 2018;

212. Radu, D., Feier, A. Steel antenna towers - from designing to manufacturing optimization, 3RD CHINA-ROMANIA SCIENCE AND TECHNOLOGY SEMINAR (CRSTS 2018), Book Series: IOP Conference Series-Materials Science and Engineering, Volume: 399, Article Number: UNSP 012047, 3rd China-Romania Science and Technology Seminar (CRSTS), APR 24-27, 2018, Brasov, ROMANIA, ISSN: 1757-8981, Published: 2018;
213. Renken, F., Piwczyk, D., Shen, W.S., Pop-Calimanu, I.M., Steinberger-Wilckens, R. A Novel Concept to Control the Powertrain in Battery Fuel Cell Hybrid Vehicles, 2018 20TH EUROPEAN CONFERENCE ON POWER ELECTRONICS AND APPLICATIONS (EPE'18 ECCE EUROPE), Book Series: European Conference on Power Electronics and Applications, 20th European Conference on Power Electronics and Applications (EPE ECCE Europe), SEP 17-21, 2018, Riga, LATVIA, ISSN: 2325-0313, ISBN: 978-9-0758-1528-3, Published: 2018;
214. Renken, F., Shen, W.S., Schurmann, U., Pop-Calimanu, I.M. Multiphase DC/DC Converter and its Use in the Powertrain of Fuel Cell Vehicles, 2018 IEEE 18TH INTERNATIONAL POWER ELECTRONICS AND MOTION CONTROL CONFERENCE (PEMC), Book Series: IEEE International Power Electronics and Motion Control Conference IP EMC, Pages: 280-286, 18th IEEE International Power Electronics and Motion Control Conference (IEEE PEMC), AUG 26-30, 2018, Budapest, HUNGARY, ISBN: 978-1-5386-4198-9, Published: 2018;
215. Ricman, R.S., Szabo, R., Gontean, A. 3D Image Reconstruction of a Robotic Arm in MATLAB from Images Acquired with FPGA, 2018 IEEE INTERNATIONAL CONFERENCE ON ENVIRONMENT AND ELECTRICAL ENGINEERING AND 2018 IEEE INDUSTRIAL AND COMMERCIAL POWER SYSTEMS EUROPE (EEEIC / I&CPS EUROPE), IEEE International Conference on Environment and Electrical Engineering / IEEE Industrial and Commercial Power Systems Europe (EEEIC / I&CPS Europe), JUN 12-15, 2018, Palermo, ITALY, ISBN: 978-1-5386-5186-5, Published: 2018;
216. Ricman, R.S., Szabo, R., Gontean, A. A Comparative Analysis of Implementation Performances for Image Processing Applications Used to Control Robotic Arms, 2018 IEEE INTERNATIONAL CONFERENCE ON ENVIRONMENT AND ELECTRICAL ENGINEERING AND 2018 IEEE INDUSTRIAL AND COMMERCIAL POWER SYSTEMS EUROPE (EEEIC / I&CPS EUROPE), IEEE International Conference on Environment and Electrical Engineering / IEEE Industrial and Commercial Power Systems Europe (EEEIC / I&CPS Europe), JUN 12-15, 2018, Palermo, ITALY, ISBN: 978-1-5386-5186-5, Published: 2018;
217. Rimescu, C., Anghel, A.A., Frigura-Iliasa, F.M., Filipescu, H. CAD Based Solution for the Refurbishment of Existing Construction Elements, 2018 IEEE 16TH WORLD SYMPOSIUM ON APPLIED MACHINE INTELLIGENCE AND INFORMATICS (SAMI 2018): DEDICATED TO THE MEMORY OF PIONEER OF ROBOTICS ANTAL (TONY) K. BEJCZY, Pages: 23-26, IEEE 16th World Symposium on Applied Machine Intelligence and Informatics (SAMI) Dedicated to the Memory of Pioneer of Robotics Antal (Tony) K. Bejczy, FEB 07-10, 2018, Kosice, SLOVAKIA, ISBN: 978-1-5386-4772-1, Published: 2018;
218. Rimescu, C., Lazarescu, E., Frigura-Iliasa, F.M., Frigura-Iliasa, M., Dolga, L., Filipescu, H.E. Study about some Two Main Dopants for a ZnO based Varistor Material with 5 Additives, Applied in Overvoltage Protection Equipment, PROCEEDINGS OF THE 2018 19TH INTERNATIONAL SCIENTIFIC CONFERENCE ON ELECTRIC POWER ENGINEERING (EPE), Book Series: International Scientific Conference on Electric Power Engineering, Pages: 212-215, 19th International Scientific Conference on Electric Power Engineering (EPE), MAY 16-18, 2018, Brno, CZECH REPUBLIC, ISSN: 2376-5623, ISBN: 978-1-5386-4612-0, Published: 2018;
219. Rob, R., Panoiu, C., Anghel, S.R. Intelligent System for Tracking and Logging the Zigzag Pantograph Motion, 2018 INNOVATIONS IN INTELLIGENT SYSTEMS AND APPLICATIONS (INISTA), IEEE (SMC) International Conference on Innovations in Intelligent Systems and Applications (INISTA), JUL 03-05, 2018, Thessaloniki, GREECE, ISBN: 978-1-5386-5150-6, Published: 2018;
220. Robu, A., Robu, N., Neagu, A. New software tools for hydrogel-based bioprinting, 2018 IEEE 12TH INTERNATIONAL SYMPOSIUM ON APPLIED COMPUTATIONAL INTELLIGENCE AND INFORMATICS (SACI), Pages: 473-478, 12th IEEE International Symposium on Applied Computational Intelligence and Informatics (SACI), MAY 17-19, 2018, Timisoara, ROMANIA, ISBN: 978-1-5386-4640-3, Published: 2018;
221. Rohatinovici, N.C., Cowell, S.R., Daus, L., Poulin, P., Dragoi, V., Balas, V.E., Beiu, V. On Algorithms for Evaluating the Reliability of Large Hammock Networks, 2018 7TH INTERNATIONAL CONFERENCE ON COMPUTERS COMMUNICATIONS AND CONTROL (ICCCC 2018), Pages: 131-135, 7th International Conference on Computers Communications and Control (ICCCC), MAY 08-12, 2018, Oradea, ROMANIA, ISBN: 978-1-5386-1934-6, Published: 2018;
222. Rohatinovici, N.C., Prostean, O., Balas, V.E. On Reliability of 3D Hammock Networks, 2018 IEEE 12TH INTERNATIONAL SYMPOSIUM ON APPLIED COMPUTATIONAL INTELLIGENCE AND INFORMATICS (SACI), Pages: 149-153, 12th IEEE International Symposium on Applied Computational Intelligence and Informatics (SACI), MAY 17-19, 2018, Timisoara, ROMANIA, ISBN: 978-1-5386-4640-3, Published: 2018;

223. Roman, R.C., Precup, R.E., David, R.C. Second Order Intelligent Proportional-Integral Fuzzy Control of Twin Rotor Aerodynamic Systems, 6TH INTERNATIONAL CONFERENCE ON INFORMATION TECHNOLOGY AND QUANTITATIVE MANAGEMENT, Book Series: Procedia Computer Science, Volume: 139, Pages: 372-380, 6th International Conference on Information Technology and Quantitative Management (ITQM), OCT 20-21, 2018, Omaha, NE, ISSN: 1877-0509, Published: 2018;
224. Roman, R.C., Radac, M.B., Tureac, C., Precup, R.E. Data-Driven Active Disturbance Rejection Control of Pendulum Cart Systems, 2018 IEEE CONFERENCE ON CONTROL TECHNOLOGY AND APPLICATIONS (CCTA), Pages: 933-938, IEEE Conference on Control Technology and Applications (CCTA), AUG 21-24, 2018, Copenhagen, DENMARK, ISBN: 978-1-5386-7698-1, Published: 2018;
225. Rotar, R., Jurj, S.L., Opritoiu, F., Vladutiu, M. Position Optimization Method for a Solar Tracking Device Using the Cast-Shadow Principle, 2018 IEEE 24TH INTERNATIONAL SYMPOSIUM FOR DESIGN AND TECHNOLOGY IN ELECTRONIC PACKAGING (SIITME), Book Series: International Symposium for Design and Technology in Electronic Packaging, Pages: 61-70, 24th IEEE International Symposium on Design and Technology in Electronic Packaging (SIITME), OCT 25-28, 2018, Iasi, ROMANIA, ISSN: 2641-287X, ISBN: 978-1-5386-5577-1, Published: 2018;
226. Rus, S., Tamasila, M., Mocan, M., Ivascu, L., Turi, A. The Challenges of the Banking System: Trends, Development, and Open Questions, INNOVATION MANAGEMENT AND EDUCATION EXCELLENCE THROUGH VISION 2020, VOLS I –XI, Pages: 4350-4356, 31st International-Business-Information-Management-Association Conference, APR 25-26, 2018, Milan, ITALY, ISBN: 978-0-9998551-0-2, Published: 2018;
227. Sadowski, T., Craciun, E., Marsavina, L. Brittle Behavior of Ceramic Matrix Composites Made of 2 Different Phases, 7TH INTERNATIONAL CONFERENCE ON STRUCTURAL ANALYSIS OF ADVANCED MATERIALS (ICSAAM 2017), Book Series: AIP Conference Proceedings, Volume: 1932, Article Number: UNSP 030036, 7th International Conference on Structural Analysis of Advanced Materials (ICSAAM), SEP 19-22, 2017, Bucharest, ROMANIA, ISSN: 0094-243X, ISBN: 978-0-7354-1624-6, Published: 2018;
228. Sandru, F., Nanu, S., Negrea, R., Popescu, A., Fericele, S. Data Acquisition and Processing with Fusion Sensors, Used in Algorithms for Increasing Accuracy of Position Measurement of Mobile Robots, SOFT COMPUTING APPLICATIONS, SOFA 2016, VOL 2, Book Series: Advances in Intelligent Systems and Computing, Volume: 634, Pages: 565-578, 7th International Workshop on Soft Computing Applications (SOFA), AUG 24-26, 2016, Arad, ROMANIA, ISSN: 2194-5357, eISSN: 2194-5365, ISBN: 978-3-319-62524-9, Published: 2018;
229. Schweisthal, B.B., Benyo, B., Szlavecz, A., Kovacs, K., Lascu, M. Extension of a Glycaemic Control Medical Application with New Functions and Ergonomic User Interface Elements, 2018 13TH INTERNATIONAL SYMPOSIUM ON ELECTRONICS AND TELECOMMUNICATIONS (ISETC), Book Series: International Symposium on Electronics and Telecommunications, Pages: 52-55, 13th International Symposium on Electronics and Telecommunications (ISETC), NOV 08-09, 2018, Timisoara, ROMANIA, ISSN: 2475-787X, ISBN: 978-1-5386-5925-0, Published: 2018;
230. Sebu, M.L., Ciocarlie, H. Collaborative Business Process Solution Considering an Ontological Dimension of Process Models, SOFT COMPUTING APPLICATIONS, SOFA 2016, VOL 2, Book Series: Advances in Intelligent Systems and Computing, Volume: 634, Pages: 177-193, 7th International Workshop on Soft Computing Applications (SOFA), AUG 24-26, 2016, Arad, ROMANIA, ISSN: 2194-5357, eISSN: 2194-5365, ISBN: 978-3-319-62524-9, Published: 2018;
231. Shen, W.S., Pop-Calimanu, I.M., Renken, F. Test bench to optimize the Powertrain in Battery-Electric and Fuel-Cell Vehicles, 2018 13TH INTERNATIONAL SYMPOSIUM ON ELECTRONICS AND TELECOMMUNICATIONS (ISETC), Book Series: International Symposium on Electronics and Telecommunications, Pages: 141-144, 13th International Symposium on Electronics and Telecommunications (ISETC), NOV 08-09, 2018, Timisoara, ROMANIA, ISSN: 2475-787X, ISBN: 978-1-5386-5925-0, Published: 2018;
232. Sicoe, O., Popa, M. A Mixed Fixed Point and Floating Point Graphics Pipeline, APPLIED PHYSICS, SYSTEM SCIENCE AND COMPUTERS, Book Series: Lecture Notes in Electrical Engineering, Volume: 428, Pages: 145-151, 1st International Conference on Applied Physics, System Science and Computers (APSAC), SEP 28-30, 2016, Dubrovnik, CROATIA, ISSN: 1876-1100, eISSN: 1876-1119, ISBN: 978-3-319-53934-8; 978-3-319-53933-1, Published: 2018;
233. Silaghi, A.M., Aipu, R.A., De Sabata, A., Alexa, F. Absorber Lined Shielded Enclosure Chamber Validation, 2018 13TH INTERNATIONAL SYMPOSIUM ON ELECTRONICS AND TELECOMMUNICATIONS (ISETC), Book Series: International Symposium on Electronics and Telecommunications, Pages: 147-152, 13th International Symposium on Electronics and Telecommunications (ISETC), NOV 08-09, 2018, Timisoara, ROMANIA, ISSN: 2475-787X, ISBN: 978-1-5386-5925-0, Published: 2018;

234. Silaghi, A.M., Aipu, R.A., De Sabata, A., Nicolae, P.M. Near-field scan technique for reducing Radiated Emissions in Automotive EMC, 2018 JOINT IEEE INTERNATIONAL SYMPOSIUM ON ELECTROMAGNETIC COMPATIBILITY AND 2018 IEEE ASIA-PACIFIC SYMPOSIUM ON ELECTROMAGNETIC COMPATIBILITY (EMC/APEMC), Pages: 831-836, Joint 60th IEEE International Symposium on Electromagnetic Compatibility (EMC) / IEEE Asia-Pacific Symposium on Electromagnetic Compatibility (APEMC), MAY 14-18, 2018, Singapore, SINGAPORE, ISBN: 978-1-5090-5997-3, Published: 2018;
235. Silaghi, A.M., Motateanu, A., Aipu, R., De Sabata, A. Far field versus Near field measurement in Automotive environment, 2018 IEEE 24TH INTERNATIONAL SYMPOSIUM FOR DESIGN AND TECHNOLOGY IN ELECTRONIC PACKAGING (SIITME), Book Series: International Symposium for Design and Technology in Electronic Packaging, Pages: 173-176, 24th IEEE International Symposium on Design and Technology in Electronic Packaging (SIITME), OCT 25-28, 2018, Iasi, ROMANIA, ISSN: 2641-287X, ISBN: 978-1-5386-5577-1, Published: 2018;
236. Simo, A., Kilyeni, S., Barbulescu, C. GA Based Multi-stage Transmission Network Expansion Planning, SOFT COMPUTING APPLICATIONS, SOFA 2016, VOL 1, Book Series: Advances in Intelligent Systems and Computing, Volume: 633, Pages: 47-59, 7th International Workshop on Soft Computing Applications (SOFA), AUG 24-26, 2016, Arad, ROMANIA, ISSN: 2194-5357, eISSN: 2194-5365, ISBN: 978-3-319-62521-8, Published: 2018;
237. Simo, A., Barbulescu, C., Kilyeni, S., Dragos, C. LoRa based Energy Efficiency Improving in Manufacturing Processes, 2018 7TH INTERNATIONAL CONFERENCE ON COMPUTERS COMMUNICATIONS AND CONTROL (ICCCC 2018), Pages: 156-161, 7th International Conference on Computers Communications and Control (ICCCC), MAY 08-12, 2018, Oradea, ROMANIA, ISBN: 978-1-5386-1934-6, Published: 2018;
238. Sinescu, C., Bradu, A., Duma, V.F., Topala, F.I., Negrutiu, M.L., Podoleanu, A.G. Temperature variations in sintering ovens for metal ceramic dental prostheses. Non-destructive assessment using OCT, LASERS IN DENTISTRY XXIV, Book Series: Proceedings of SPIE, Volume: 10473, Article Number: UNSP 104730C, Conference on Lasers in Dentistry XXIV, JAN 28, 2018, San Francisco, CA, ISSN: 0277-786X, eISSN: 1996-756X, ISBN: 978-1-5106-1432-1, Published: 2018;
239. Sirbu, M.A., Baiasu, A., Bogdan, R., Crisan-Vida, M. Smart traffic sign detection on autonomous car, 2018 13TH INTERNATIONAL SYMPOSIUM ON ELECTRONICS AND TELECOMMUNICATIONS (ISETC), Book Series: International Symposium on Electronics and Telecommunications, Pages: 19-22, 13th International Symposium on Electronics and Telecommunications (ISETC), NOV 08-09, 2018, Timisoara, ROMANIA, ISSN: 2475-787X, ISBN: 978-1-5386-5925-0, Published: 2018;
240. Sora, I., Cernazanu-Glavan, C. Investigating Attributes that Characterize Important Classes in Object Oriented Systems, 2018 IEEE 12TH INTERNATIONAL SYMPOSIUM ON APPLIED COMPUTATIONAL INTELLIGENCE AND INFORMATICS (SACI), Pages: 461-466, 12th IEEE International Symposium on Applied Computational Intelligence and Informatics (SACI), MAY 17-19, 2018, Timisoara, ROMANIA, ISBN: 978-1-5386-4640-3, Published: 2018;
241. Stefan, B., Costache, S.B., Crisan-Vida, M., Stoicu-Tivadar, L., Mitrache, D. Integrated System for Monitoring People with Diabetes. Monitoring of Pregnant Women, PROCEEDINGS OF THE 6TH CONGRESS OF THE ULTRASOUND SOCIETY IN OBSTETRICS AND GYNECOLOGY / 34TH FETUS AS A PATIENT INTERNATIONAL CONGRESS, Pages: 306-311, 6th Congress of the Ultrasound-Society-in-Obstetrics-and-Gynecology, MAY 16-19, 2018, Bucharest, ROMANIA, ISBN: 978-88-85813-20-5, Published: 2018;
242. Stirb, I. NUMA-BTLP: A static algorithm for thread classification, 2018 5TH INTERNATIONAL CONFERENCE ON CONTROL, DECISION AND INFORMATION TECHNOLOGIES (CODIT), Book Series: International Conference on Control Decision and Information Technologies, Pages: 882-887, 5th International Conference on Control, Decision and Information Technologies (CoDIT), APR 10-13, 2018, Thessaloniki, GREECE, ISSN: 2576-3555, ISBN: 978-1-5386-5065-3, Published: 2018;
243. Stoia, D.I., Vigaru, C., Rusu, L. Relative and Absolute Angles Computed from Pathologic Gait Data, ACOUSTICS AND VIBRATION OF MECHANICAL STRUCTURES (AVMS-2017), Book Series: Springer Proceedings in Physics, Volume: 198, Pages: 201-206, 14th International Conference on Acoustics and Vibration of Mechanical Structures (AVMS), MAY 25-26, 2017, Timisoara, ROMANIA, ISSN: 0930-8989, eISSN: 1867-4941, ISBN: 978-3-319-69823-6; 978-3-319-69822-9, Published: 2018;
244. Stolojescu-Crisan, C. A Diversified Denoising System for Biomedical Images, 2018 13TH INTERNATIONAL SYMPOSIUM ON ELECTRONICS AND TELECOMMUNICATIONS (ISETC), Book Series: International Symposium on Electronics and Telecommunications, Pages: 29-32, 13th International Symposium on Electronics and Telecommunications (ISETC), NOV 08-09, 2018, Timisoara, ROMANIA, ISSN: 2475-787X, ISBN: 978-1-5386-5925-0, Published: 2018;



245. Stuparu, A., Baya, A., Bosioc, A., Anton, L., Mos, D. Modelling the Operation Curves of two Similar High Power Centrifugal Pumps, INTERNATIONAL CONFERENCE OF NUMERICAL ANALYSIS AND APPLIED MATHEMATICS (ICNAAM 2017), Book Series: AIP Conference Proceedings, Volume: 1978, Article Number: UNSP 030005-1, International Conference of Numerical Analysis and Applied Mathematics (ICNAAM), SEP 25-30, 2017, Thessaloniki, GREECE, ISSN: 0094-243X, ISBN: 978-0-7354-1690-1, Published: 2018;
246. Svoboda, M., Musuroi, S., Ancuti, M.C., Sorandaru, C., Biba, D. Experimental model for measuring the currents in the rotor cage bars of an induction machine, 2018 INTERNATIONAL CONFERENCE AND EXPOSITION ON ELECTRICAL AND POWER ENGINEERING (EPE), Book Series: International Conference and Exposition on Electrical and Power Engineering, Pages: 91-96, 10th International Conference and Expositions on Electrical and Power Engineering (EPE), OCT 18-19, 2018, Iasi, ROMANIA, ISSN: 2471-6855, ISBN: 978-1-5386-5062-2, Published: 2018;
247. Szabo, A., Binzar, T., Nadaban, S., Pater, F. Some Properties of Fuzzy Bounded Sets in Fuzzy Normed Linear Spaces, INTERNATIONAL CONFERENCE OF NUMERICAL ANALYSIS AND APPLIED MATHEMATICS (ICNAAM 2017), Book Series: AIP Conference Proceedings, Volume: 1978, Article Number: UNSP 390009-1, International Conference of Numerical Analysis and Applied Mathematics (ICNAAM), SEP 25-30, 2017, Thessaloniki, GREECE, ISSN: 0094-243X, ISBN: 978-0-7354-1690-1, Published: 2018;
248. Szabo, R., Gontean, A. Configurable Online Test Creation in PHP with Auto Evaluation of Students Running on the Server of the Sun Trackers, 2018 IEEE 24TH INTERNATIONAL SYMPOSIUM FOR DESIGN AND TECHNOLOGY IN ELECTRONIC PACKAGING (SIITME), Book Series: International Symposium for Design and Technology in Electronic Packaging, Pages: 165-168, 24th IEEE International Symposium on Design and Technology in Electronic Packaging (SIITME), OCT 25-28, 2018, Iasi, ROMANIA, ISSN: 2641-287X, ISBN: 978-1-5386-5577-1, Published: 2018;
249. Szabo, R., Gontean, A. Optical Distance Measurement System Analysis at Different Color Temperatures of the Light Source Used by Sun Trackers, 2018 IEEE 24TH INTERNATIONAL SYMPOSIUM FOR DESIGN AND TECHNOLOGY IN ELECTRONIC PACKAGING (SIITME), Book Series: International Symposium for Design and Technology in Electronic Packaging, Pages: 134-137, 24th IEEE International Symposium on Design and Technology in Electronic Packaging (SIITME), OCT 25-28, 2018, Iasi, ROMANIA, ISSN: 2641-287X, ISBN: 978-1-5386-5577-1, Published: 2018;
250. Szabo, R. Search Engine Creation for a Web Platform Where the Data of Sun Follower Robots are Stored, 2018 26TH TELECOMMUNICATIONS FORUM (TELFOR), Pages: 615-618, 26th Telecommunications Forum (TELFOR), NOV 20-21, 2018, Belgrade, SERBIA, ISBN: 978-1-5386-7171-9, Published: 2018;
251. Szabo, R. Terrestrial Drone Creation from Rover, Robotic Arm and Raspberry Pi with Sun Tracker Function, 2018 13TH INTERNATIONAL SYMPOSIUM ON ELECTRONICS AND TELECOMMUNICATIONS (ISETC), Book Series: International Symposium on Electronics and Telecommunications, Pages: 59-62, 13th International Symposium on Electronics and Telecommunications (ISETC), NOV 08-09, 2018, Timisoara, ROMANIA, ISSN: 2475-787X, ISBN: 978-1-5386-5925-0, Published: 2018;
252. Szabo, R. The Creation Process of an Individual Grade Sender via E-Mail for Students Running on the Server of Sun Trackers, 2018 26TH TELECOMMUNICATIONS FORUM (TELFOR), Pages: 611-614, 26th Telecommunications Forum (TELFOR), NOV 20-21, 2018, Belgrade, SERBIA, ISBN: 978-1-5386-7171-9, Published: 2018;
253. Szedlak-Stinean, A.I., Precup, R.E., Bojan-Drăgoc, C.A., Mituletu, I.C. Feedback Control Solutions for an Electromechanical Process with Rigid Body Dynamics, 2018 IEEE 12TH INTERNATIONAL SYMPOSIUM ON APPLIED COMPUTATIONAL INTELLIGENCE AND INFORMATICS (SACI), Pages: 599-605, 12th IEEE International Symposium on Applied Computational Intelligence and Informatics (SACI), MAY 17-19, 2018, Timisoara, ROMANIA, ISBN: 978-1-5386-4640-3, Published: 2018;
254. Szedlak-Stinean, A.I., Bojan-Drăgoc, C.A., Precup, R.E., Radac, M.B. Gain-Scheduling Control Solutions for a Strip Winding System with Variable Moment of Inertia, IFAC PAPERSONLINE, Volume: 51, Issue: 4, Pages: 370-375, 3rd IFAC Conference on Advances in Proportional-Integral-Derivative Control (PID), MAY 09-11, 2018, Ghent, BELGIUM, ISSN: 2405-8963, Published: 2018;
255. Szeidert, I., Filip, I., Prostean, O., Vasar, C. Above Modelling and Adaptive Control of a Double Winded Induction Generator, 2018 IEEE 12TH INTERNATIONAL SYMPOSIUM ON APPLIED COMPUTATIONAL INTELLIGENCE AND INFORMATICS (SACI), Pages: 97-101, 12th IEEE International Symposium on Applied Computational Intelligence and Informatics (SACI), MAY 17-19, 2018, Timisoara, ROMANIA, ISBN: 978-1-5386-4640-3, Published: 2018;

256. Szuhaneck, C., Sinescu, C., Todea, C., Pop, O., Duma, V.F., Topala, F., Rominu, M., Negrutiu, M.L., Bradu, A., Podoleanu, A.G. Optical Coherence Tomography study regarding the enamel structure before and after debonding, SEVENTH INTERNATIONAL CONFERENCE ON LASERS IN MEDICINE, Book Series: Proceedings of SPIE, Volume: 10831, Article Number: UNSP 108310P, 7th Romanian-Society-for-Laser-in-Dentistry (SRLS) International Conference on Lasers in Medicine / 1st Congress of Laser in Dentistry, JUL 13-15, 2017, Timisoara, ROMANIA, ISSN: 0277-786X, eISSN: 1996-756X, ISBN: 978-1-5106-2288-3, Published: 2018;
257. Tamasila, M., Rus, S. Evaluation of the Romanian Banking System: Proposal of a Strategic Development Framework, INNOVATION MANAGEMENT AND EDUCATION EXCELLENCE THROUGH VISION 2020, VOLS I –XI, Pages: 4357-4365, 31st International-Business-Information-Management-Association Conference, APR 25-26, 2018, Milan, ITALY, ISBN: 978-0-9998551-0-2, Published: 2018;
258. Tarfulea, N., Frigura-Iliasa, F.M., Vatau, D., Frigura-Iliasa, M., Andea, P., Balcu, F.I. Research and Development of a New Material for Metal Oxide Varistors, 2018 IEEE INTERNATIONAL CONFERENCE ON ENVIRONMENT AND ELECTRICAL ENGINEERING AND 2018 IEEE INDUSTRIAL AND COMMERCIAL POWER SYSTEMS EUROPE (EEEIC / I&CPS EUROPE), IEEE International Conference on Environment and Electrical Engineering / IEEE Industrial and Commercial Power Systems Europe (EEEIC / I&CPS Europe), JUN 12-15, 2018, Palermo, ITALY, ISBN: 978-1-5386-5186-5, Published: 2018;
259. Teban, T.A., Precup, R.E., Lunca, E.C., Albu, A., Bojan-Drăgoc, C.A., Petriu, E.M. Recurrent Neural Network Models for Myoelectric-based Control of a Prosthetic Hand, 2018 22ND INTERNATIONAL CONFERENCE ON SYSTEM THEORY, CONTROL AND COMPUTING (ICSTCC), Book Series: International Conference on System Theory Control and Computing, Pages: 603-608, 22nd International Conference on System Theory, Control and Computing (ICSTCC), OCT 10-12, 2018, Sinaia, ROMANIA, ISSN: 2372-1618, ISBN: 978-1-5386-4444-7, Published: 2018;
260. Tej, M.L., Holban, S. Comparative Study of Clustering Distance Measures to Determine Neural Network Architectures, 2018 IEEE 12TH INTERNATIONAL SYMPOSIUM ON APPLIED COMPUTATIONAL INTELLIGENCE AND INFORMATICS (SACI), Pages: 189-194, 12th IEEE International Symposium on Applied Computational Intelligence and Informatics (SACI), MAY 17-19, 2018, Timisoara, ROMANIA, ISBN: 978-1-5386-4640-3, Published: 2018;
261. Tej, M.L., Holban, S. Determining Neural Network Architecture Using Data Mining Techniques, 2018 14TH INTERNATIONAL CONFERENCE ON DEVELOPMENT AND APPLICATION SYSTEMS (DAS), Pages: 156-163, 14th International Conference on Development and Application Systems (DAS), MAY 24-26, 2018, Suceava, ROMANIA, ISBN: 978-1-5386-1493-8, Published: 2018;
262. Tej, M.L., Holban, S. Determining Optimal Neural Network Architecture Using Regression Methods, 2018 14TH INTERNATIONAL CONFERENCE ON DEVELOPMENT AND APPLICATION SYSTEMS (DAS), Pages: 180-189, 14th International Conference on Development and Application Systems (DAS), MAY 24-26, 2018, Suceava, ROMANIA, ISBN: 978-1-5386-1493-8, Published: 2018;
263. Ternauciu, A., Andone, D., Ciuclea, C. Development of a Moodle Extension for Improving the Management of the Educational Process, E-LEARNING CHALLENGES AND NEW HORIZONS, VOL 4, Book Series: eLearning and Software for Education, Pages: 363-371, 14th International Scientific Conference on eLearning and Software for Education - eLearning Challenges and New Horizons, APR 19-20, 2018, Bucharest, ROMANIA, ISSN: 2066-026X, Published: 2018;
264. Tidrea, A., Korodi, A. WebNavIGSS web-based software solution for IGSS SCADA applications, 2018 26TH MEDITERRANEAN CONFERENCE ON CONTROL AND AUTOMATION (MED), Book Series: Mediterranean Conference on Control and Automation, Pages: 418-423, 26th Mediterranean Conference on Control and Automation (MED), JUN 19-22, 2018, Zadar, CROATIA, ISSN: 2325-369X, ISBN: 978-1-5386-7890-9, Published: 2018;
265. Toc, S.I., Korodi, A. Modbus-OPC UA Wrapper using Node-RED and IoT-2040 with application in the water industry, 2018 IEEE 16TH INTERNATIONAL SYMPOSIUM ON INTELLIGENT SYSTEMS AND INFORMATICS (SISY 2018), Book Series: International Symposium on Intelligent Systems and Informatics, Pages: 99-103, IEEE 16th International Symposium on Intelligent Systems and Informatics (SISY), SEP 13-15, 2018, Subotica, SERBIA, ISSN: 1949-047X, ISBN: 978-1-5386-6841-2, Published: 2018;
266. Todinca, D., Sora, I., Butoianu, D.E., Precup, R.E. A Novel Method to Compute the Membership Value of the States of Fuzzy Automata, 2018 IEEE 12TH INTERNATIONAL SYMPOSIUM ON APPLIED COMPUTATIONAL INTELLIGENCE AND INFORMATICS (SACI), Pages: 107-112, 12th IEEE International Symposium on Applied Computational Intelligence and Informatics (SACI), MAY 17-19, 2018, Timisoara, ROMANIA, ISBN: 978-1-5386-4640-3, Published: 2018;

267. Tomodan, E.R., Caleanu, C.D. Bag of Features vs Deep Neural Networks for Face Recognition, 2018 13TH INTERNATIONAL SYMPOSIUM ON ELECTRONICS AND TELECOMMUNICATIONS (ISETC), Book Series: International Symposium on Electronics and Telecommunications, Pages: 89-92, 13th International Symposium on Electronics and Telecommunications (ISETC), NOV 08-09, 2018, Timisoara, ROMANIA, ISSN: 2475-787X, ISBN: 978-1-5386-5925-0, Published: 2018;
268. Topirceanu, A., Udrescu, M. Topological Fragility versus Antifragility: Understanding the Impact of Real-time Repairs in Networks Under Targeted Attacks, 2018 IEEE/ACM INTERNATIONAL CONFERENCE ON ADVANCES IN SOCIAL NETWORKS ANALYSIS AND MINING (ASONAM), Pages: 1215-1222, IEEE/ACM International Conference on Advances in Social Networks Analysis and Mining (ASONAM), AUG 28-31, 2018, Barcelona, SPAIN, ISBN: 978-1-5386-6051-5, Published: 2018;
269. Totorean, A.F., Hudrea, I.C., Bernad, S.I., Gaita, D.I. Anastomosis Configuration Influence on Local Hemodynamics in Coronary Bypass, INTERNATIONAL CONFERENCE OF NUMERICAL ANALYSIS AND APPLIED MATHEMATICS (ICNAAM 2017), Book Series: AIP Conference Proceedings, Volume: 1978, Article Number: UNSP 030015-1, International Conference of Numerical Analysis and Applied Mathematics (ICNAAM), SEP 25-30, 2017, Thessaloniki, GREECE, ISSN: 0094-243X, ISBN: 978-0-7354-1690-1, Published: 2018;
270. Totorean, A.F., Hudrea, I.C., Sandor, B. Fluid Dynamics in Simplified pre and post-Stented Coronary Bifurcation, ACOUSTICS AND VIBRATION OF MECHANICAL STRUCTURES (AVMS-2017), Book Series: Springer Proceedings in Physics, Volume: 198, Pages: 173-180, 14th International Conference on Acoustics and Vibration of Mechanical Structures (AVMS), MAY 25-26, 2017, Timisoara, ROMANIA, ISSN: 0930-8989, eISSN: 1867-4941, ISBN: 978-3-319-69823-6; 978-3-319-69822-9, Published: 2018;
271. Turc, C.G., Carauusu, C., Belgiu, G. Part cost estimation in injection moulding, MODTECH INTERNATIONAL CONFERENCE - MODERN TECHNOLOGIES IN INDUSTRIAL ENGINEERING VI (MODTECH 2018), Book Series: IOP Conference Series-Materials Science and Engineering, Volume: 400, Article Number: 042058, 6th International Conference on Modern Technologies in Industrial Engineering (ModTech), JUN 13-16, 2018, Constanta, ROMANIA, ISSN: 1757-8981, Published: 2018;
272. Turi, A., Mocan, M., Goncalves, G., Ivascu, L. The Role of a Car Manufacturing Plant's Internal Performance in Shaping Strategic Management Choices in Automotive Industry, INNOVATION MANAGEMENT AND EDUCATION EXCELLENCE THROUGH VISION 2020, VOLS IV -VI, Pages: 3396-3404, 31st International-Business-Information-Management-Association Conference, APR 25-26, 2018, Milan, ITALY, ISBN: 978-0-9998551-0-2, Published: 2018;
273. Turi, A., Mocan, M., Ivascu, L., Szilagyi, A. BACHELOR'S DEGREE GRADUATES PERCEPTIONS TOWARDS PURSUING THEIR ACADEMIC STUDIES, PROCEEDINGS OF THE 15TH INTERNATIONAL CONFERENCE EFFICIENCY AND RESPONSIBILITY IN EDUCATION 2018 (ERIE), Book Series: Efficiency and Responsibility in Education ..., Pages: 402-415, 15th International Conference on Efficiency and Responsibility in Education (ERIE), JUN 06-08, 2018, Prague, CZECH REPUBLIC, ISSN: 2336-744X, ISBN: 978-80-213-2858-7, Published: 2018;
274. Ungureanu, V., Both, I., Burca, M., Grosan, M., Neagu, C., Dubina, D. Experimental investigations on built-up cold-formed steel beams connected by resistance spot welding, PROCEEDINGS OF THE 12TH INTERNATIONAL CONFERENCE ON ADVANCES IN STEEL-CONCRETE COMPOSITE STRUCTURES (ASCCS 2018), Pages: 205-212, 12th International Conference on Advances in Steel-Concrete Composite Structures (ASCCS), JUN 27-29, 2018, Valencia, SPAIN, ISBN: 978-84-9048-601-6, Published: 2018;
275. Ungureanu, V., Kotelko, M., Borkowski, L., Grudziecki, J. Behaviour of Thin-Walled Cold-Formed Steel Members in Eccentric Compression, COMPUTER METHODS IN MECHANICS (CMM2017), Book Series: AIP Conference Proceedings, Volume: 1922, Article Number: UNSP 080006, 22nd International Conference on Computer Methods in Mechanics (CMM), SEP 13-16, 2017, Lublin, POLAND, ISSN: 0094-243X, ISBN: 978-0-7354-1614-7, Published: 2018;
276. Ursu, D., Dabici, A., Bublea, N.C., Duteanu, N., Miclau, N., Vajda, M. Effect of mixed-phase copper oxide on photovoltaic performance of p-type dye-sensitized solar cells, 2018 13TH INTERNATIONAL SYMPOSIUM ON ELECTRONICS AND TELECOMMUNICATIONS (ISETC), Book Series: International Symposium on Electronics and Telecommunications, Pages: 67-69, 13th International Symposium on Electronics and Telecommunications (ISETC), NOV 08-09, 2018, Timisoara, ROMANIA, ISSN: 2475-787X, ISBN: 978-1-5386-5925-0, Published: 2018;
277. Ursulescu, O., Ilies, B., Simion, G. Driver Drowsiness Detection Based on Eye Analysis, 2018 13TH INTERNATIONAL SYMPOSIUM ON ELECTRONICS AND TELECOMMUNICATIONS (ISETC), Book Series: International Symposium on Electronics and Telecommunications, Pages: 11-14, 13th International Symposium on Electronics and Telecommunications (ISETC), NOV 08-09, 2018, Timisoara, ROMANIA, ISSN: 2475-787X, ISBN: 978-1-5386-5925-0, Published: 2018;

278. Vartolomei, M. Study Over Corruption and European Economic Convergence, INNOVATION MANAGEMENT AND EDUCATION EXCELLENCE THROUGH VISION 2020, VOLS I –XI, Pages: 5466-5475, 31st International-Business-Information-Management-Association Conference, APR 25-26, 2018, Milan, ITALY, ISBN: 978-0-9998551-0-2, Published: 2018;
279. Vartolomei, M., Mocan, M., Bobia, E., Nemes, M., Ivascu, L. Survey Over Corruption and Economic Development Sustainability in Romanian Public Management System, INNOVATION MANAGEMENT AND EDUCATION EXCELLENCE THROUGH VISION 2020, VOLS I -XI, Pages: 4494-4502, 31st International-Business-Information-Management-Association Conference, 25-26, 2018, Milan, ITALY, ISBN: 978-0-9998551-0-2, Published: 2018;
280. Vasar, C., Prostean, O., Filip, I., Szeidert, I. Wind Energy Conversion System - a Laboratory Setup, 2018 IEEE 12TH INTERNATIONAL SYMPOSIUM ON APPLIED COMPUTATIONAL INTELLIGENCE AND INFORMATICS (SACI), Pages: 313-317, 12th IEEE International Symposium on Applied Computational Intelligence and Informatics (SACI), MAY 17-19, 2018, Timisoara, ROMANIA, ISBN: 978-1-5386-4640-3, Published: 2018;
281. Vasile, M.C. Smart Networking of Cities, a Must in the Global Paradigm, INNOVATION MANAGEMENT AND EDUCATION EXCELLENCE THROUGH VISION 2020, VOLS IV –VI, Pages: 2316-2329, 31st International-Business-Information-Management-Association Conference, APR 25-26, 2018, Milan, ITALY, ISBN: 978-0-9998551-0-2, Published: 2018;
282. Vasile, V.C., Magu, G., Cosnita, R., Nafornta, C., Isar, A., Borda, M. EGNOS Performance Improvements Using Monitoring Stations in Romania, 2018 13TH INTERNATIONAL SYMPOSIUM ON ELECTRONICS AND TELECOMMUNICATIONS (ISETC), Book Series: International Symposium on Electronics and Telecommunications, Pages: 307-312, 13th International Symposium on Electronics and Telecommunications (ISETC), NOV 08-09, 2018, Timisoara, ROMANIA, ISSN: 2475-787X, ISBN: 978-1-5386-5925-0, Published: 2018;
283. Vasile, V.C., Nafornta, C., Borda, M. Comparative Study of Satellite Navigation Systems, 2018 13TH INTERNATIONAL SYMPOSIUM ON ELECTRONICS AND TELECOMMUNICATIONS (ISETC), Book Series: International Symposium on Electronics and Telecommunications, Pages: 318-323, 13th International Symposium on Electronics and Telecommunications (ISETC), NOV 08-09, 2018, Timisoara, ROMANIA, ISSN: 2475-787X, ISBN: 978-1-5386-5925-0, Published: 2018;
284. Vasilescu, C., Todea, A., Paul, C., Benea, I.C., Nan, A., Turcu, R., Peter, F. New multilayer magnetic biocatalyst for esterification and transesterification reactions, NEW BIOTECHNOLOGY, Meeting Abstract: P1-19, Volume: 44, Pages: S73-S73, ISSN: 1871-6784, eISSN: 1876-4347, Supplement: S, Published: 2018;
285. Veliscu, T.M., Bejinariu, A.C., Bere-Semeredi, I., Draghici, A. A PROPOSE APPROACH FOR STRATEGIC PERFORMANCE MANAGEMENT FOR PUBLIC ADMINISTRATION ORGANIZATIONS, PERFORMANCE MANAGEMENT OR MANAGEMENT PERFORMANCE?, Book Series: Review of Management and Economic Engineering International Management Conference, Pages: 466-477, 6th Review of Management and Economic Engineering International Management Conference, SEP 20-22, 2018, Cluj Napoca, ROMANIA, ISSN: 2247-8639, Published: 2018;
286. Vilceanu, C.B., Grecea, C., Herban, S. Opportunities and Challenges in Higher Education System: Knowledge Transfer by e-Learning vs. Traditional Methods, ELEARNING CHALLENGES AND NEW HORIZONS, VOL 4, Book Series: eLearning and Software for Education, Pages: 253-258, 14th International Scientific Conference on eLearning and Software for Education - eLearning Challenges and New Horizons, APR 19-20, 2018, Bucharest, ROMANIA, ISSN: 2066-026X, Published: 2018;
287. Vilceanu, C.B., Herban, S., Banescu, O.A. Cultural Heritage Modeling Potential Highlighted by e-Learning Resources, ELEARNING CHALLENGES AND NEW HORIZONS, VOL 4, Book Series: eLearning and Software for Education, Pages: 476-483, 14th International Scientific Conference on eLearning and Software for Education - eLearning Challenges and New Horizons, APR 19-20, 2018, Bucharest, ROMANIA, ISSN: 2066-026X, Published: 2018;
288. Vilceanu, C.B., Herban, S., Meng, Q.Y., Alionescu, A. Using LiDAR for Urban Green Space Monitoring, INTERNATIONAL CONFERENCE OF NUMERICAL ANALYSIS AND APPLIED MATHEMATICS (ICNAAM 2017), Book Series: AIP Conference Proceedings, Volume: 1978, Article Number: UNSP 390010-1, International Conference of Numerical Analysis and Applied Mathematics (ICNAAM), SEP 25-30, 2017, Thessaloniki, GREECE, ISSN: 0094-243X, ISBN: 978-0-7354-1690-1, Published: 2018;
289. Vulcu, C., Don, R., Ciutina, A. Semi-continuous beam-to-column joints for slim-floor systems in seismic zones, PROCEEDINGS OF THE 12TH INTERNATIONAL CONFERENCE ON ADVANCES IN STEEL-CONCRETE COMPOSITE STRUCTURES (ASCCS 2018), Pages: 587-594, 12th International Conference on Advances in Steel-Concrete Composite Structures (ASCCS), JUN 27-29, 2018, Valencia, SPAIN, ISBN: 978-84-9048-601-6, Published: 2018;

290. Vutan, A.M., Gruescu, C.M., Lovasz, E.C., Ciupe, V. Discussion on Cobb Angle variation during progressive lateral flexion of the trunk, 8TH INTERNATIONAL CONFERENCE ON ADVANCED CONCEPTS IN MECHANICAL ENGINEERING, Book Series: IOP Conference Series-Materials Science and Engineering, Volume: 444, Article Number: 052020, 8th International Conference on Advanced Concepts in Mechanical Engineering (ACME), JUN 07-08, 2018, Iasi, ROMANIA, ISSN: 1757-8981, Published: 2018;
291. Xiao, X.Y., Xu, W., Li, X., Du, G.H., Boldea, I., Ma, G.T., Yu, K.L. Novel Homopolar Linear Synchronous Motor with E-shape Primary Core, 2018 21ST INTERNATIONAL CONFERENCE ON ELECTRICAL MACHINES AND SYSTEMS (ICEMS), Book Series: International Conference on Electrical Machines and Systems ICEMS, Pages: 1821-1826, 21st International Conference on Electrical Machines and Systems (ICEMS), OCT 07-10, 2018, Jeju, SOUTH KOREA, ISBN: 978-8-9865-1020-1, Published: 2018;
292. Zaharie, I., Erdodi, G.M., Dudu, M. The Functioning of a Wind System at its Maximum Power, 2018 IEEE 12TH INTERNATIONAL SYMPOSIUM ON APPLIED COMPUTATIONAL INTELLIGENCE AND INFORMATICS (SACI), Pages: 585-588, 12th IEEE International Symposium on Applied Computational Intelligence and Informatics (SACI), MAY 17-19, 2018, Timisoara, ROMANIA, ISBN: 978-1-5386-4640-3, Published: 2018;
293. Zheng, H.R., Wassan, J.T., Moisescu, M.A., Stoicu-Tivadar, L., Miranda, J., Crisan-Vida, M., Sacala, I.S., Badnjevic, A., Chorbev, I., Jakimovski, B. Multiscale Computing in Systems Medicine: a Brief Reflection, PROCEEDINGS 2018 IEEE INTERNATIONAL CONFERENCE ON BIOINFORMATICS AND BIOMEDICINE (BIBM), Book Series: IEEE International Conference on Bioinformatics and Biomedicine-BIBM, Pages: 2190-2196, IEEE International Conference on Bioinformatics and Biomedicine (BIBM), DEC 03-06, 2018, Madrid, SPAIN, ISSN: 2156-1125, eISSN: 2156-1133, ISBN: 978-1-5386-5488-0, Published: 2018.

\* The data was obtained from Web of Science - Clarivate Analytics in 15 July 2019



# BOOKS





## EVOLUTION OF BOOKS UNDER AFFILIATIONS OF UPT 2014 - 2018

A published book is indisputable evidence of research that has been performed, completed, and accepted by peers. Book is also an indicator of achievement of a certain academic standard. Besides communication of a finalised piece of research, the book is the basis for further opinions, views and critiques from fellow professionals and academics separated by time and distance. Most importantly, it represents the only permanent record of scientific work that has been completed.

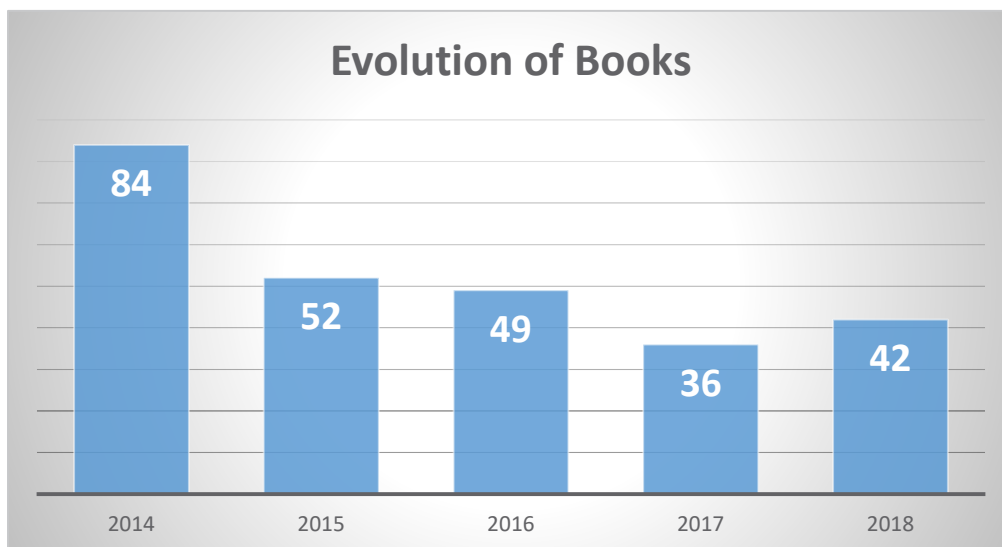

In this chapter we present the books written by our professors and researchers, published at Romanian publishers as well as at international prestigious publishers.



## *Books in highlight*



**SERIES OF INTERNATIONAL CONFERENCES ON STABILITY AND DUCTILITY OF STEEL STRUCTURES - SDSS  
A SPECIAL ISSUE OF *STEEL CONSTRUCTION, DESIGN AND RESEARCH* JOURNAL,  
COORDINATED BY TWO UPT PROFESSORS**

Since 1974, with the first edition in London, the World wide recognized series of SDSS International Conferences have travelled around the World. The last edition, of May 2016, In Timișoara, was jointly organized by the Politehnica University, through CMMC, and Timisoara Branch of Romanian Academy, under the brands of European Convention for Constructional Steelwork-ECCS and USA Structural Stability Re-search Council (SSRC).

268 authors from 26 countries on 5 continents are contributing with 116 scientific papers, published in Volume of Ernst & Sohn /Wiley. The Chairman of that Conference was Acad. Dan Dubina, while the Scientific Secretary was prof. Viorel Ungureanu, both from Politehnica University Timișoara.

The prestigious Journal "Steel Construction, Design and Research" (Ernst & Sohn /Wiley), has published in *special issue* - No. 1, Vol.11, February 2018, under coordination of D. Dubina and V. Ungureanu, as Guest Editors, a selection of 8 papers, *in extenso* versions, considered to be among the most representative papers presented within SDSS 2016.

They are :

1. Buckling-restrained brace with high structural performance (*Mamoru Iwata, Mitsumasa Midorikawa, Kazuhisa Koyano*)
2. Buckling design of axially compressed steel silos on discrete supports (*Arne Jansseune, Jan Belis, Wouter De Corte*)
3. The "combined approach" for the design of shear diaphragms made of trapezoidal profile sheeting (*Thomas Misiek, Gerhard Huck, Saskia Käpplein*)
4. Design by advanced analysis - 3D benchmark problems. Members subject to major- and minor-axis flexure (*Ronald D. Ziemian, Jean C. Batista Abreu*)
5. Initial bow imperfections  $e_0$  for the verification of flexural buckling according to Eurocode 3 Part 1-1, additional considerations (*Joachim Lindner, Ulrike Kuhlmann, Fabian Jörg*)
6. Experiments on the rotational capacity of beams made of high-strength steel (*Nicole Schillo, Markus Feldmann*)
7. Lateral torsional buckling design imperfections for use in nonlinear FEA (*Bert Snijder, Rob van der Aa, Hèrm Hofmeyer, Dianne van Hove*)
8. Simulation of dynamic response of steel moment frames following sudden column loss. Experimental calibration of numerical model and application (*Ioan Marginean, Florea Dinu, Dan Dubina*)



*Steel Construction* publishes peer reviewed papers covering the entire field of steel construction research. In the interests of "construction without depletion", it skillfully combines steel with other forms of construction employing concrete, glass, cables and membranes to form integrated steelwork systems. Since 2010 *Steel Construction* is the official journal for ECCS- European Convention for Constructional Steelwork members. You will find more information about membership on the ECCS homepage.

Topics include:

Design and construction of structures, *Methods of analysis and calculation*, Experimental and theoretical research projects and results, *Composite construction*, Steel buildings and bridges, *Cable and membrane structures*, Structural glazing, *Masts and towers*, Vessels, cranes and hydraulic engineering structures, *Fire protection*, Lightweight structures

In addition, *Steel Construction* includes reports on innovations from the construction industry. An internationally renowned Editorial Board assures a highly interesting selection of topics and guarantees the high standard of the contributions.

Publisher: Ernst & Sohn, an Wiley brand, ISSN 1867-0520.



# Books List





1. Arieșanu, C., Iosif, I.R., Linear algebra and geometry for electrical engineering, Editura Politehnica, Timișoara, 2018, ISBN 978-606-35-0172-2;
2. Baltă H., Lucaci R., Kovaci M., Information theory and coding. Practical works, Editura Politehnica, Timișoara, 2018, ISBN 978-606-35-0262-0;
3. Belega D., Măsurări electrice și electronice, Editura Politehnica, Timișoara, 2018, ISBN 978-606-35-0263-7;
4. Brata S., Termotehnică. Determinări experimentale și exemple de calcul, Editura Politehnica, Timișoara, 2018, ISBN 978-606-35-0249-1;
5. Bucos, M., Ternauciu, A., Drăgulescu, B., Date semistructurate, Editura Politehnica, Timișoara, 2018, ISBN 978-606-35-0193-7;
6. Ciurdariu L., Curs de algebră și geometrie, Editura Politehnica, Timișoara, 2018, ISBN 978-606-35-0256-9;
7. Davidescu, M., Introducere în termodinamica chimică. Ediția a II-a, Editura Politehnica, Timișoara, 2018, ISBN 978-606-35-0213-2;
8. De Sabata C., The Painter's secret garden, Editura Politehnica, Timișoara, 2018, ISBN 978-606-35-0255-2;
9. Dejica-Cartîș, D., Dragomir, G.M., Gherheș, V., Șimon, S., 25 de ani de comunicare și traductologie în Universitatea Politehnica Timișoara, Editura Politehnica, Timișoara, 2018, ISBN 978-606-35-0236-1;
10. Dogariu, E., Relații publice, Editura Politehnica, Timișoara, 2018, ISBN 978-606-35-0210-1;
11. Drăghici, A., Căruțașu, N., Ivașcu, L., Managementul riscurilor ocupaționale, Editura Politehnica, Timișoara, 2018, ISBN 978-606-554-067-5;
12. Gherheș V., Graduates, professionals, specialists. Slalom among experiences., Editura Politehnica, Timișoara, 2018, ISBN 978-606-35-0252-1;
13. Ghiormez, L., Pănoiu, M., Modelarea, identificarea și conducerea proceselor din electrochimie, Editura Politehnica, Timișoara, 2018, ISBN 978-606-35-0209-5;
14. Ionel I., Petrilean C.D., GLOREP 2018 – CD, Editura Politehnica, Timișoara, 2018, ISBN 978-606-35-0238-5;
15. Ionel, S., Hodoni. Istorie și cultură, Editura Politehnica, Timișoara, 2018, ISBN 978-606-35-0227-9;
16. Lascu, D., In Memoriam Tiberiu Mureșan, Editura Politehnica, Timișoara, 2018, ISBN 978-606-35-0235-4;
17. Lovasz, E.C., In Memoriam Dan Perju, Editura Politehnica, Timișoara, 2018, ISBN 978-606-35-0218-7;
18. Negru, R., Marșavina, L., Metode moderne de evaluare a integrității și durabilității – CD, Editura Politehnica, Timișoara, 2018, ISBN 978-606-35-0173-9;
19. Negru, R., Pîrvulescu, L.D., Sava, M., Neguț, N., Rezistența materialelor I. Teorie și aplicații – CD, Editura Politehnica, Timișoara, 2018, ISBN 978-606-35-0171-5;
20. Olteanu, M.T., Bogdan, V., Întâlnirea cu îngerul. Mihai Teodor Olteanu în dialog cu Vasile Bogdan, Editura Politehnica, Timișoara, 2018, ISBN 978-606-35-0240-8;

21. Onița, M.I., Elemente de grafică și video, Editura Politehnica, Timișoara, 2018, ISBN 978-606-35-0203-3;
22. Osaci, M., Cunțan, C.D., Electrotehnică și electronică, Editura Politehnica, Timișoara, 2018, ISBN 978-606-35-0243-9;
23. Pană, A., Băloi, A., Transportul și distribuția energiei electrice. Culegere de aplicații pentru proiectare, Editura Politehnica, Timișoara, 2018, ISBN 978-606-554-879-4;
24. Pană, A.M., Rusnac, C., Dumitrel, G.A., Dispersia poluanților atmosferici. Aplicații, Editura Politehnica, Timișoara, 2018, ISBN 978-606-35-0234-7;
25. Păușescu, I.M., Todea, A., Controlul fitosanitar al alimentelor. Noțiuni teoretice și practice, Editura Politehnica, Timișoara, 2018, ISBN 978-606-350170-8;
26. Pop, F., Proiectarea tehnică asistată de calculator. Aplicații, Editura Politehnica, Timișoara, 2018, ISBN 978-606-35-0164-7;
27. Pugna, A., Miclea, Ș., Analiza valorii. Sinteze pentru activități practice și studii de caz, Editura Politehnica, Timișoara, 2018, ISBN 978-606-35-0208-8;
28. Sârbu, I., Tokar, A., Water Distribution Systems. Numerical Modelling and Optimisation, Editura Politehnica, Timișoara, 2018, ISBN 978-606-35-0207-1;
29. Șerban V.A., Neguț N., Palea A., Dies Academicus 2015, Editura Politehnica, Timișoara, 2018, ISBN 978-606-35-0254-5;
30. Șimon S., Dejica-Carțiș A., Stoian C.E., Kriston A., Dictionar explicativ poliglot de termeni din domeniul educației (română, engleză, germană, franceză), Editura Politehnica, Timișoara, 2018, ISBN 978-606-35-0251-4;
31. Șimon, S., Stoian, C.E., Dejica-Carțiș, A., Kriston, A., A MULTILINGUAL DICTIONARY OF EDUCATION: ENGLISH-GERMAN-FRENCH-ROMANIAN, JATEPress, 2018, ISBN 978-963-315-375-8;
32. Șimon, S., Stoian, C.E., The Language of the Arts and Literature: An English-Romanian and Romanian-English Dictionary, Cambridge Scholars Publishing, 2018, ISBN (10): 1-5275-1368-8, ISBN (13): 978-1-5275-1368-6;
33. Stoian, C.E., Șimon, S., An English-Romanian and Romanian-English Cultural Thematic Dictionary, Cambridge Scholars Publishing, 2018, ISBN 978-1-5275-1136-1;
34. Stratulat M., Stănescu D., Circuite digitale. Principii și aplicații, Editura Politehnica, Timișoara, 2018, ISBN 978-606-35-0264-4;
35. Todea, A., Păușescu, I.M., Analiza senzorială a produselor alimentare. Lucrări practice de laborator, Editura Politehnica, Timișoara, 2018, ISBN 978-606-35-0169-2;
36. Toduț, C., Consolidarea antisismică a panourilor mari prefabricate. Aplicații cu materiale composite, Editura Politehnica, Timișoara, 2018, ISBN 978-606-35-0206-4;
37. Tokar, D., Țenchea, A., Aparate cu combustibili gazoși. Instalare și verificare, Editura Politehnica, Timișoara, 2018, ISBN 978-606-35-0229-3;
38. Tulcan, A., Monografia specializării de Tehnologia Construcțiilor de Mașini la 60 de ani. 1957 – 2017, Editura Politehnica, Timișoara, 2018, ISBN 978-606-35-0190-6;

39. Uțu, I.D., Mitelea, I., Introducere în ingineria suprafețelor, Editura Politehnica, Timișoara, 2018, ISBN 978-606-35-0228-6;
40. Vartolomei M., Contabilitate. Partea I. Bazele contabilității. Vol. I, Editura Politehnica, Timișoara, 2018, ISBN 978-606-35-0257-6/978-606-35-0259-6;
41. Vartolomei M., Contabilitate. Partea II. Contabilitatea financiară. Contabilitatea principalelor operații economice. Vol. I, Editura Politehnica, Timișoara, 2018, ISBN 978-606-35-0257-6/978-606-35-0560-6;
42. \* \* \* Steel Construction: Design and Research, special issue - No. 1, Volume 11, Ernst & Sohn / Wiley, February 2018, ISSN 1867-0520.



# Book Chapters List



1. Hadaruga, N.G., Bandur, G.N., Hadaruga, D.I. Thermal Analyses of Cyclodextrin Complexes, CYCLODEXTRIN FUNDAMENTALS, REACTIVITY AND ANALYSIS, Book Series: Environmental Chemistry for a Sustainable World, Pages: 155-221, SPRINGER INTERNATIONAL PUBLISHING AG, CHAM, SWITZERLAND, 2018, ISSN: 2213-7114, eISSN: 2213-7122, ISBN: 978-3-319-76159-6; 978-3-319-76158-9, Book DOI: 10.1007/978-3-319-76159-6;
2. Jadhav, D.A., Ghangrekar, M.M., Duteanu, N. Recent Progress Towards Scaling Up of MFCs, MICROBIAL FUEL CELL: A BIOELECTROCHEMICAL SYSTEM THAT CONVERTS WASTE TO WATTS, Pages: 443-457, SPRINGER INTERNATIONAL PUBLISHING AG, CHAM, SWITZERLAND, 2018, ISBN: 978-3-319-66793-5; 978-3-319-66792-8, Book DOI: 10.1007/978-3-319-66793-5;
3. Pugna, A., Potra, S., Negrea, R., Mocan, M. DMAIC Six Sigma for Complex Processes Improvement, UNDERSTANDING SIX SIGMA: CONCEPTS, APPLICATIONS AND CHALLENGES, Book Series: Management Science - Theory and Applications, Pages: 25-63, Nova Science Publishers, Inc. New-York, 2018, ISBN: 978-1-53614-174-0.

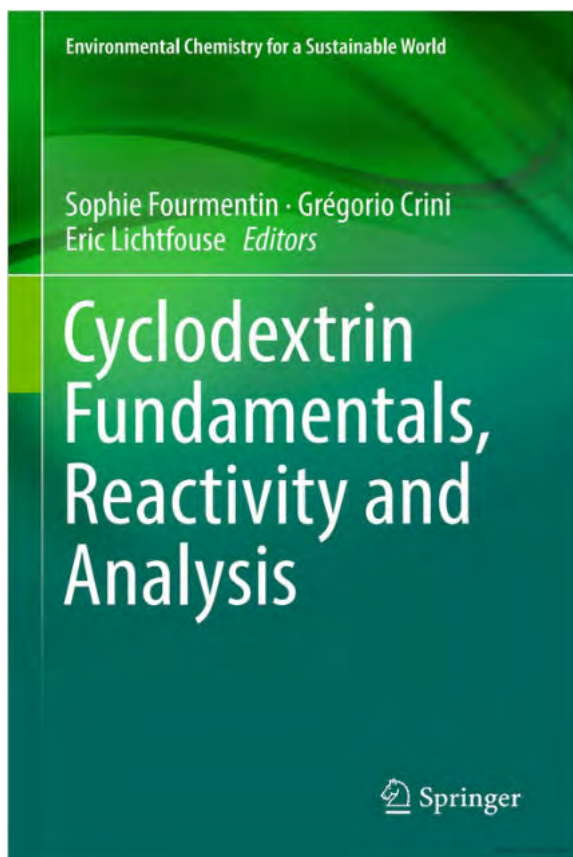

Indexed in Web of Science - Clarivate Analytics

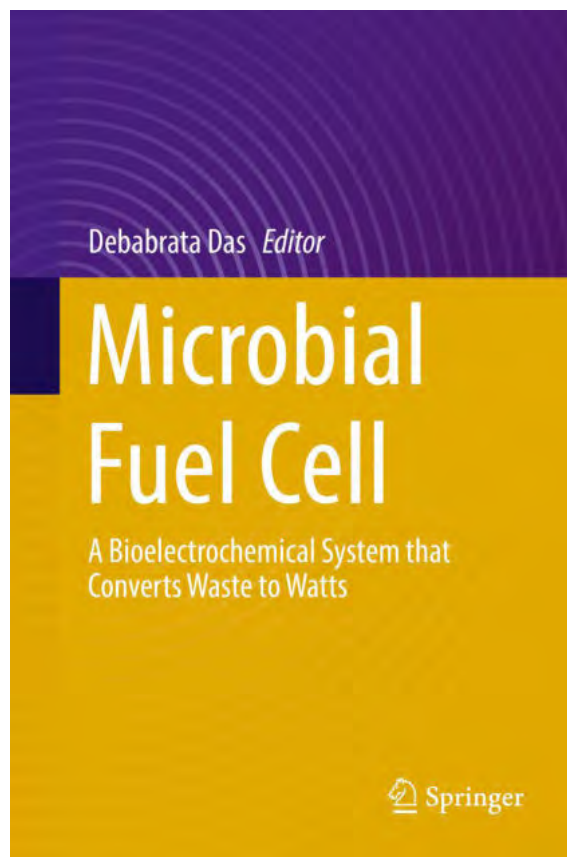

Indexed in Web of Science - Clarivate Analytics







**Politehnica  
University  
Timisoara**



Piata Victoriei No. 2  
RO 300006, Timisoara  
Fax: +40 256 40 30 21  
Email: [rector@upt.ro](mailto:rector@upt.ro)  
[www.upt.ro](http://www.upt.ro)



Editura **POLITEHNICA**

ISSN 1841-2769  
ISSN-L 1841-2769