

# Research Report 2017

**Research  
Annual  
Report**

Politehnica  
University  
of Timisoara  
2017

# Research Report 2017

Research Report, 2017  
The second edition of Research Report, revised and expanded.

Copyright © Editura Politehnica 2018

All rights reserved to Politehnica University of Timisoara.

No part of this booklet may be reproduced or transmitted in any form or by any means, electronic or mechanical, including photocopy, recording, or any information storage and retrieval system now known or to be invented, without permission in writing from the publisher, except by a reviewer who wishes to quote brief passages in connection with a review written for inclusion in a magazine, newspaper, or broadcast.

## Editorial team

### Editor:

Assoc. Prof. Liviu Ioan CĂDARIU-BRĂILOIU, PhD

### Co-Editors:

Agnes STEPANIAN, Ladislau WALKOVSKY, Andreia Claudia LĂZĂRESCU

Layout & cover design: Eugen STAN

Editura Politehnica

Bd. Vasile Pârvan nr. 2b

300223 Timișoara, România

Tel./Fax. 0256/404.677

E-mail: editura@upt.ro

ISSN 1841-2769

Research  
Report 2017

**Research  
Annual  
Report**  
Politehnica  
University  
of Timisoara  
2017



## Structure of the report

Introducing the Report .....	5
Research Centers .....	9
Scientific Excellence Awards .....	15
Projects supported by public funds .....	35
National Research Projects .....	37
Research and Development Projects for Young Researchers ...	123
International Research Projects .....	129
Projects supported by private funds .....	153
Patents .....	169
Granted Patents .....	173
Honorary Members .....	179
Doctor Honoris Causa .....	183
Habilitation Thesis .....	187
PhD Thesis .....	201
Scientific Conferences .....	209
Scientific Journals .....	217
ISI Papers .....	223
ISI Papers in highlight .....	227
Papers in ISI Journals .....	247
Papers in ISI Proceedings .....	265
Books .....	297
Books in highlight .....	301
Books List .....	307
Book Chapters List .....	311



# Introducing the Report





“It’s not the walls that make a school, but the spirit living inside.”  
King Ferdinand I, 1923

The needs for a modern society, in the context of a competitive global market, require highly skilled human resource development. In this context, the role of universities in the innovation process has increased continuously over time because the development of new products or technologies depends more and more on the findings of scientific research.

Established in 1920, shortly after the union of Romanian territories, in a European context marked by the redefinition of states and by the aftermath of World War I, the Polytechnic School in Timisoara – as it was originally called – was the answer to one of the requirements of the Romanian society of the time, namely the formation of engineers.

The mission of the Politehnica University of Timisoara is to offer nationally competitive and internationally recognized opportunities for Learning, Research, and Innovation at the highest levels of excellence. As a resource of knowledge for the public, the university builds partnerships with other educational institutions, community organizations, government agencies, and the private sector to fulfill the requirements for competences of the societal environment through superior professional training for students and graduates.

The present Research Report of Politehnica University of Timisoara gathers the main results obtained through the research activities carried out within the university in 2017, Politehnica being renowned as a remarkable actor on the stage of scientific research, both at national and international level. Our research activity is facilitated by the existence of twenty-six research centres specialized in fields that are capital for the sustainable development of any modern society. Each of these research centres brings together various prestigious researchers, whom, by their effort and vision, provide PUT with the incentives needed to contribute to the progress of our society.

Most of the research activity carried out by our institution is financed through external sources, obtained either from national and international calls for projects, or through agreements with private companies. This represents a confirmation of the superior quality of the research, but also of the prestige and professional deontology of the researchers affiliated to our institution. Politehnica’s reputation as an institution of advanced research is also emphasized by the patents obtained by its researchers, by the medals and prizes obtained in both national and international competitions, and by the collaborations with important research centres and institutes from Romania and from abroad.

Each year we select the most talented young researchers for our doctoral school, providing them with the opportunity to transform their knowledge and ideas into the innovations of tomorrow. Many of them take part in peer learning programs and consolidate in this way the relationship between our university and similar partner institutions. They strive for becoming doctors in science.

This report is divided into twelve sections, each one presenting a specific component of the research activity performed within the institution.

The first section focuses on the research infrastructure, which comprises the twenty-six research centres hosted by the university. The order in which they are presented is given by the research fields. The research centres, respectively teams of researchers, on different themes, are highly important for our university since they manage to put into practice the scientific research strategy of the university successfully, within the framework of numerous grants and contracts won by competition. The research results are materialized in papers, patents and products, all bringing for the University prestige, as well as important funds.

# Research Report 2017

---

The second section of the Research Report is dedicated to the Scientific Excellence Awards. These prestigious awards celebrate those colleagues who have made a significant contribution in their field of research and continue to inspire future generations to get involved in science.

The third and fourth sections include the research projects implemented by the university. The third section includes the projects supported by public funds, both national and international, while the fourth one includes the projects supported by private funds awarded by companies. For the purposes of this report, we have chosen the most relevant projects for our the most representative projects for our research strategy.

The innovative capacity of the Politehnica University of Timisoara is supported by teachers and scientific researchers through patents and utility models invented, presented in the fifth section.

Politehnica University of Timisoara recognizes scientific excellence by conferring the honorary degrees of Doctor Honoris Causa and Honorary Professor to distinguished Researchers for their contribution to the development of PUT of continuous support, as shown in section six of this Report.

Sections seven and eight include habilitation theses and PhD theses held in 2017 in our University.

Section nine presents an overview of the most relevant scientific conferences that brought together scholars and professionals from Romania and from abroad. The conferences hosted by our university encouraged the dialogue, facilitated the exchange of ideas, and offered a great opportunity for new collaborations.

The tenth section gathers the scientific journals that have been published by our institution. This category includes journals specialized in various fields, such as computer science, chemistry and environmental engineering, electronics and communications, economics and social sciences, electrical engineering, mathematics and physics, hydrotechnics, physical education and sport, modern languages, etc.

The dissemination of the research results and findings is an integral part of the research process and the career in academia. Section eleven presents the most relevant scientific researches that have been published in 2017. It comprises the results obtained by our researchers, namely the papers that obtained recognition from some of the most prestigious journals, from both Romania and abroad.

And finally the twelfth section comprises a collection of books written by our researchers, most of them published under Politehnica Publishing House.

Through research we generate ideas, through ideas we generate innovation and through innovation we contribute to the improvement of the quality of life; this is why research is our priority.

# RESEARCH CENTRES





### Research Institute for Renewable Energy

Director: prof. Viorel UNGUREANU

Contact: viorel.ungureanu@upt.ro, <http://www.icer.ro/>



### Research Centre for Computers and Information Technology

Director: prof. Vladimir-Ioan CREȚU

Contact: vladimir.cretu@upt.ro, <http://cercetare.cs.upt.ro/>



### Research Centre for Automatic Systems Engineering

Director: prof. Radu-Emil PRECUP

Contact: radu.precup@upt.ro, <http://www.aut.upt.ro/centru-cercetare/>

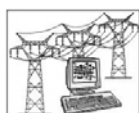

### Research Centre for Power Systems Analysis and Optimization

Director: prof. Ștefan KILYENI

Contact: stefan.kilyeni@upt.ro, <http://www.et.upt.ro/index.php?sublink=1694&link=10&pag=2&lang=ro>



### Research Centre for Smart Energy Conversion and Storage

Director: prof. Nicolae MUNTEAN

Contact: nicolae.muntean@upt.ro,  
<http://www.et.upt.ro/index.php?link=10&sublink=1695&pag=1&lang=en>



### Research Centre for Intelligent Electronic Systems

Director: prof. Marius OTEȘTEANU

Contact: marius.otesteanu@upt.ro, <http://ccesi.upt.ro/>



### Research Centre for Intelligent Signal Processing

Director: prof. Alexandru ISAR

Contact: alexandru.isar@upt.ro, <http://www.tc.etc.upt.ro/ispr/>



### Research Centre for Multimedia

Director: prof. Radu VASIU

Contact: radu.vasiu@upt.ro, <http://www.cm.upt.ro>



### Research Centre for Environmental Science and Engineering

Director: prof. Rodica PODE

Contact: rodica.pode@upt.ro, <http://www.chim.upt.ro/ro/cercetare/centre-cercetare/centru-de-cercetare-in-stiinta-si-ingineria-mediului>



## Research Centre for Inorganic Materials and Alternative Energies

Director: prof. Ioan LAZĂU

Contact: [ioan.lazau@upt.ro](mailto:ioan.lazau@upt.ro), <http://www.chim.upt.ro/ro/cercetare/centre-cercetare/centru-de-cercetare-pentru-materiale-anorganice-si-energii-alternative>



## Research Centre for Organic, Macromolecular and Natural Compounds' Chemistry and Engineering

Director: prof. Corneliu DAVIDESCU

Contact: [corneliu.davidescu@upt.ro](mailto:corneliu.davidescu@upt.ro), <http://www.chim.upt.ro/ro/cercetare/centre-cercetare/centru-de-cercetare-in-chimia-si-ingineria-compusilor-organici-macromoleculari-si-naturali>



## Research Centre for Mechanics of Materials and Structural Safety

Director: prof. Dan DUBINĂ

Contact: [dan.dubina@upt.ro](mailto:dan.dubina@upt.ro), <http://www.ct.upt.ro/centre/cemsig/>



## Research Centre for Hidrotechnical Engineering and Environmental Protection

Director: prof. Constantin FLORESCU

Contact: [constantin.florescu@upt.ro](mailto:constantin.florescu@upt.ro), <http://www.ct.upt.ro/centre/cchpm/index.htm>



## Research Centre for Building Services

Director: s.l. Calin SEBARCHIEVICI

Contact: [calin.sebarchievici@upt.ro](mailto:calin.sebarchievici@upt.ro), <http://www.ct.upt.ro/centre/ccic/>



## Research Centre for Retrofitting of Constructions

Director: prof. Tamas NAGY GYORGY

Contact: [tamas.nagy-gyorgy@upt.ro](mailto:tamas.nagy-gyorgy@upt.ro), <http://www.ct.upt.ro/centre/reco/>



## Research Centre in Infrastructures for Constructions and Transportation

Director: prof. Liviu Adrian CIUTINĂ

Contact: [adrian.ciutina@upt.ro](mailto:adrian.ciutina@upt.ro), <http://www.ct.upt.ro/centre/ict/>



## Research Centre for Mechatronics and Robotics

Director: prof. Inocențiu MANIU

Contact: [inocentiu.maniu@upt.ro](mailto:inocentiu.maniu@upt.ro), <http://mctr.mec.upt.ro/activitate-de-cercetare>



### Research Centre for Medical Engineering

Director: prof. Liviu MARȘAVINA  
Contact: liviu.marsavina@upt.ro, <http://cmpicsu.upt.ro/>



### Research Centre for Integrated Engineering

Director: prof. George DRĂGHICI  
Contact: george.draghici@upt.ro, <http://imf.upt.ro/CCII/index.html>



### Research Centre for Processing and Characterization of Advanced Materials

Director: conf. Bogdan RADU  
Contact: bogdan.radu@upt.ro, <https://sites.google.com/view/ccpcma/home>



### Research Centre for Complex Fluid Systems Engineering

Director: prof. Romeo SUSAN-RESIGA  
Contact: romeo.resiga@upt.ro, <https://mh.mec.upt.ro/>



### Research Centre for Thermal Machines and Equipments, Transportation and Environmental Pollution Control

Director: prof. Ioana IONEL  
Contact: ioana.ionel@upt.ro, <http://mettcp.mec.upt.ro/>



### Research Centre for Engineering and Management

Director: prof. Monica IZVERCIANU  
Contact: monica.izvercianu@upt.ro, <http://www.mpt.upt.ro/pag/centru%20cercetare.html>



### Research Centre for Urban Planning

Director: prof. Radu RADOSLAV  
Contact: radu.radoslav@upt.ro, <http://ccddt.blogspot.ro>



### Research Centre for Advanced Study Methods for Physical Phenomena

Director: prof. Dumitru TOADER  
Contact: dumitru.toader@upt.ro, <http://www.et.upt.ro/ro/departaments/bazele-fizice-ale-ingineriei>



### Research Center for Materials and Industrial Technologies

Director: prof. Teodor HEPUȚ  
Contact: teodor.heput@upt.ro, <http://www.fih.upt.ro/ccmti/>





# SCIENTIFIC EXCELLENCE AWARDS



## Elsevier's Scopus Awards Romania 2017 Award for Excellence in Global Contribution Radu-Emil PRECUP, Mircea-Bogdan RĂDAC & Ștefan PREITL

The Elsevier Scopus Award for Excellence in Global Contribution is awarded to a specific research program that contributes significantly to a scientific field or matter of global importance, in accordance with Romania's currently publicized research strategies. The awardee is chosen using the SciVal metric "Competencies," which is measured at the national level.

Data from Elsevier's Scopus and SciVal are used to identify the nominees and determine the winning research program. All currently available data from all Romanian programs are collected and analyzed for this award.

The winners of the Elsevier Scopus Award for Excellence in Global Contribution are Radu-Emil PRECUP, Mircea-Bogdan RĂDAC and Ștefan PREITL, Politehnica University of Timisoara, for research in area of Control and Systems Engineering, Artificial Intelligence and Electrical and Electronic Engineering.



The Winners of Scopus Awards Romania 2017 event took place on October 26<sup>th</sup>, 2017, in Iasi, Romania.

## Romanian Academy 2017 "Aurel Vlaicu" Award Prof. Vasile MARINCA, PhD & Prof. Nicolae HERIȘANU, PhD

On December 15, 2017, the Romanian Academy awarded the "Aurel Vlaicu Award" to Prof. Vasile Marinca and Prof. Nicolae Herisanu for the monograph "The Optimal Homotopy Asymptotic Method. Engineering Applications", published by the famous publisher SPRINGER Verlag in 2015.

The method developed in this book was proposed for the first time in the scientific literature by the two authors in 2008 and received up to now more than 600 citations from other authors.

The entire monograph is based on the scientific research done by the two authors, being presented in detail 41 case studies related to various fields of research, such as technical mechanics, mechanical vibration, fluid mechanics, thermodynamics, electrical engineering, and so on.

Explicit analytical solutions are obtained for nonlinear dynamical systems specific to the above mentioned fields and these solutions are validated by comparisons with numerical solutions, a very good accuracy being emphasized in each case.

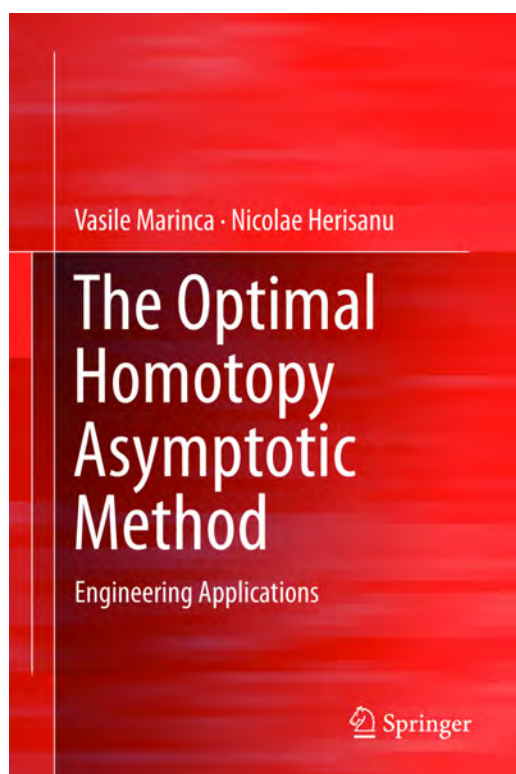

Date of award ceremony: December 15, 2017, at 10 am, Hall of the Romanian Academy, Bucharest

Web: <http://www.acad.ro/bdar/galeriiFoto/foto2017-1215St78.php>

It is to remark that up to now, this monograph is present in more than 200 university libraries worldwide, according to the international catalog WorldCat ([www.worldcat.org](http://www.worldcat.org)).

## Politehnica University of Timisoara CLAAS Award for EXCELLENCE IN RESEARCH Assist. Prof. Emanoil LINUL, PhD

CLAAS award for  
EXCELLENCE IN RESEARCH  
in the academic year 2016-2017



Emanoil Linul – Assist. Professor, PhD.  
Department of Mechanics and Strength of Materials,  
Politehnica University of Timisoara



- He is 33 years old;
- In the years 2016, 2017 he published 14 scientific papers in the ISI circuit, 12 papers in ISI indexed Journals and 2 papers in ISI Proceedings, 9 being located in the first two quartiles (6 in Q1 Journals, 3 in Q2 Journals).
- He is first author/correspondent author at 6 out of 14 mentioned papers.
- He has  $H_{index} = 9$  - WOS and over 200 citations highlighted in WOS;
- He has  $H_{index} = 9$  - Scopus and over 250 citations highlighted in Scopus;
- He has  $H_{index} = 11$  - Google Scholar and over 390 citations highlighted in Google Scholar;
- He has published in the entire research activity 40 scientific papers in the ISI circuit, of which 31 in ISI Journals;
- He leads, as a Director, a research project obtained in the internal competition Research Development Projects - Young Researchers;
- Scientific areas of interest are: fracture mechanics, composite materials, porous and cellular materials;
- Received Awards and Distinctions:
  1. A Research Trophy + plaque signed by the Rector of UPT;
  2. A Grant of 1000 EURO to support research activities.





## Politehnica University of Timisoara Award for EXCELLENCE IN RESEARCH Assoc. Prof. Claudiu ALBULESCU, PhD

The Prize for "Excellence in Research" for the results obtained during the academic year 2016-2017

At the end of the year, Politehnica University of Timisoara awarded the "Excellence in Research" prizes to young people who achieved remarkable results during the academic year 2016-2017. As principal investigator, Claudiu Albulescu successfully finalized in 2017 a research grant for young research teams, awarded by UEFISCDI. During the academic year 2016-2017 he published 18 articles in journals and conference proceedings, indexed by Thomson Reuters. Claudiu Albulescu is currently Associate Professor at the Management Department, Faculty of Management in Production and Transports, from the Politehnica University of Timisoara. He is also associated research at CRIEF (University of Poitiers). His research fields are related to macroeconomics and monetary economics, banking and finance, energy economics, financial management and entrepreneurship.



## IEEE Conference on Computer Vision and Pattern Recognition (CVPR 2017) BEST PAPER AWARD Lecturer Codruța Orniana ANCUȚI, PhD & Lecturer Cosmin ANCUȚI, PhD

The team consisting of Codruta O. Ancuti (UPT, ETC, MEO), Cosmin Ancuti (UPT, ETC, MEO), Christophe DeVleeschouwer (University Catholique of Louvain) and Rafael Garcia (University of Girona) has been awarded with “Best Paper Award” for the paper “Locally Adaptive Color Correction for Underwater Image Dehazing and Matching” presented at CVPR workshop NTIRE 2017

(<http://www.vision.ee.ethz.ch/ntire17/>).



Codruta Orniana Ancuti  
Senior Researcher / Lecturer

I completed my Ph.D. at Hasselt University (Belgium) in 2011. Starting with 2013 I am a Lecturer at UPT. My main interest of research is image understanding and visual perception. The goal of perceptually validated approaches is to enable computers to acquire images and extract important features comparable with the human visual system and beyond. I am currently a research fellow at University of Girona (ViCOROB group), where I pursue my research on underwater image enhancement.



IEEE Conference on Computer Vision and Pattern Recognition (CVPR 2017) has been held at Honolulu Convention Center, Hawaii, US and had had an attendance of more than 5000 researcher and industry partners.

CVPR is the premier annual computer vision event comprising the main conference and several co-located workshops and short courses. With its high quality and low cost, it provides an exceptional value for students, academics and industry researchers.



Cosmin Ancuti  
Senior Researcher / Lecturer

I am lecturer at UPT and research fellow at University Catholique of Louvain, Belgium. Prior to joining UPT, I was a senior researcher at University of Hasselt, Belgium. My main research interests are image processing and computer vision.

## 4<sup>th</sup> International Multidisciplinary Scientific Conference on Social Sciences and Arts SGEM 2017 BEST SPEAKER AWARD Assoc. Prof. Mariana CERNICOVA-BUCĂ, PhD

Assoc. Prof. Mariana Cernicova-Bucă, PhD, from the Faculty of Communication Sciences (UPT), obtained the Best Speaker Award for the paper "Placing Romania on the Map" at the 4th International SGEM Conference on Social Sciences and Arts, which took place in Albena, Bulgaria in August 22-30, 2017 (<http://sgemsocial.org/>).

The Conference Proceedings Volumes (ISSN 2367-5659) are subject to indexing in ISI Web of Knowledge, Clarivate Analytics, ELSEVIER products Mendeley, CrossRef, EBSCO, ProQuest, RSCI, Google Scholar, CiteUlike, CrossRef Citedby Linking, British Library and host over 1,300 papers presented on site.

The conference is organized under the aegis of 18 national academies from three continents. The "Best speaker award", bearing a diploma and an engraved crystal trophy, is awarded at the proposal of the section moderators in which the papers are presented. The titles are presented to the laureats at a festive ceremony, at the end of the multidisciplinary conference.





## International Exhibitions ( I ), ( II ), ( III ) Medals, prizes and diplomas Ștefan PAVEL

1. The International Exhibition of Research, Innovation and Inventions "Pro Invent" the 15th edition, March 22-24, 2017, Cluj-Napoca, Romania ( I )
2. The International Exhibition of Inventions and Innovations "TRAIAN VUIA" Timișoara the 3rd edition, 7-9 June 2017 ( II )
3. The Innovation and Research Exhibition UGAL INVENT, 19-20 October 2017, Galati, Romania ( III )

### 1. Installation for decontamination of residual water in the dental unit

A / 00658 / 05.09.2013

RO129343 (A0);(A8) / 30.05.2014

Pavel Ștefan, Talpoș Niculescu Șerban, Streian Felicia, Găină Paulina Ioana, Doboși Ioan Silviu, Bratu Emanuel Adrian, Borza Ioan

- The Diploma and the Golden Medal ( II )
- The Diploma of Excellence and the Silver Medal ( III )

### 2. Lighting installation for the "ceramic chamber" compartment of the dental laboratory

RO 2013 00033

Pavel Ștefan, Talpoș-Niculescu Șerban, Streian Felicia, Găină Paulina Ioana, Doboși Ioan Silviu, Bratu Emanuel Adrian, Borza Ioan

- The Diploma and the Silver Medal ( II )
- The Diploma of Excellence ( III )

### 3. Compressed air installation for dental units

RO 2013 00050

Pavel Ștefan, Borza Ioan

- The Diploma and the Bronze Medal ( II )
- The Diploma of Excellence ( III )

### 4. Electrical installation for air disinfecting in dental units

RO 2014 00031

Pavel Ștefan, Suci Silviu Cristian, Borza Iconia Ecaterina, Hogeia Elena, Dumitrașcu Victor, Vlad Daliborca Cristina, Adam Andrei, Lăcătușu Eugen-Florin, Jifcu Deian Adrian, Tutelcă Ancuța Letiția

- The Diploma of Excellence and the Golden Medal ( I )
- The Diploma and the Golden Medal ( II )
- SPECIAL PRIZE ("Victor Babeș" University of Medicine and Pharmacy, Timișoara) ( II )
- The Diploma of Excellence ( III )

### 5. Portable device for air disinfecting from closed areas

U/00045/16.07.2015

Pavel Ștefan

- The Diploma and The Silver Medal ( II )
- The Diploma of Excellence ( III )

### 6. Portable device for pain or discomfort signaling during dental medical act

RO 2015 00055

Pavel Ștefan

- The Diploma of Excellence and the Golden Medal with Special Mention ( I )
- The Diploma and the Bronze Medal ( II )
- The Diploma of EXCELLENCE & INCDMTM TROPHY ( III )
- The Diploma of Excellence ( III )

### 7. Mobile installation for child support during pediatric radiology

U/00021/08.06.2016

Pavel Ștefan, Popoiu Călin Marius, Mocan Marian Liviu, Doboși Ioan Silviu, Șerban Dan Andrei

- The Diploma of Excellence and the Golden Medal with Special Mention ( I )
- The Diploma and the Golden Medal ( II )
- SPECIAL PRIZE with Medal ("Victor Babeș" University of Medicine and Pharmacy, Timișoara) ( II )
- The EXCELLENCE Diploma (University of Agricultural Sciences and Veterinary Medicine of Banat "Regele Mihai I") ( II )
- The Bronze Medal ( III )
- The Diploma of Excellence ( III )

### 8. Electric lighting installation for dental aesthetics

U/00018/28.04.2017

Pavel Ștefan, Krems Cristina, Mocan Marian Liviu, Doboși Ioan Silviu

- The Diploma and the Golden Medal ( II )
- The Diploma of Excellence ( III )

## European Exhibition of Creativity and Innovation - EUROINVENT

### GOLD MEDAL & DIPLOMA

Floriana Daniela STOIAN, Sorin HOLOTESCU & Oana Maria MARINICĂ

PATENT TITLE: Planar transformer with magnetic nanofluid

Patent number: RO131757-A0/2017 awarded by OSIM

Registered in the Derwent International Database Accession Number: 2017-21890U [31]

Authors: Pislaru-Danescu Lucian, Popa Marius, Ilie Cristinel Ioan, Chihaia Rares-Andrei, Babutanu Corina-Alice, Nicolaie Sergiu, Bunea Florentina, Stoian Floriana Daniela, Holotescu Sorin, Marinica Oana Maria, Morega Alexandru-Mihail, Morega Mihaela, Dumitru Jean Bogdan, Popa Nicolae-Calin

Owners: ICPE-CA Bucharest and Politehnica University Timisoara

Funding: National research project PN II PCCA no.63/2014, cod. PN-II-PT-PCCA -2013-4-0486

Short description: in OSIM Bulletin, Section Patents, no.3/2017 (in Romanian)

Event: European Exhibition of Creativity and Innovation, EUROINVENT,

May 25th, 2017, Iasi, Romania

Award: Gold medal



## American Romanian Academy of Arts and Science MENTION Assist. Prof. Delia Gabriela CĂLINOIU, PhD

Conference Title: the 41st Congress of the American Romanian Academy of Arts and Science

Conference Date: 19-22.07.2017

Conference Location: CRAIOVA, ROMANIA

Organizer(s): UNIVERSITY OF CRAIOVA

Web:

<http://www.americanromanianacademy.org/41st-congress-2017>

Short Description. Topics:

The areas of activity that ARA is presently involved in include: environment, engineering, biology, applied mathematics, physics, economy, literature, linguistics, history, politics, law, philosophy.

Publication of papers: (Published papers by:)

Publication of papers with title: "The importance of the aerosol monitoring in renewable energy".





## EXECUTIVE UNIT FOR FINANCING HIGHER EDUCATION, RESEARCH, DEVELOPMENT AND INNOVATION - UEFISCDI AWARDS - ARTICLES

Through these awards UEFISCDI aims to increase quality, impact and international visibility of Romanian research by recognizing and rewarding significant results published in prestigious journals from international senior scientific stream.

Within this competition can participate the researchers affiliated to institutions in Romania, authors of scientific articles published in journals indexed by Clarivate Analytics Science Citation Index Expanded ("Science"), Social Sciences Citation Index ("Social Sciences") or Arts & Humanities Citation Index ("Arts & Humanities").

More information at <http://uefiscdi.gov.ro/Public/cat/471/Premierea-rezultatelor-cercetarii.html>

1. Buse, C., O'Regan, D., Saiarli, O., Tabassum, A. Hyers-Ulam stability and discrete dichotomy for difference periodic systems, BULLETIN DES SCIENCES MATHÉMATIQUES, Volume: 140, Issue: 8, Pages: 908-934, ISSN: 0007-4497, eISSN: 1952-4773, 2016;
2. Cimporescu, A., Todea, A., Badea, V., Paul, C., Peter, F. Efficient kinetic resolution of 1,5-dihydroxy-1,2,3,4-tetrahydronaphthalene catalyzed by immobilized Burkholderia cepacia lipase in batch and continuous-flow system, PROCESS BIOCHEMISTRY, Volume: 51, Issue: 12, Pages: 2076-2083, ISSN: 1359-5113, eISSN: 1873-3298, 2016;
3. Davidescu, C.M., Ardelean, R., Popa, A. Performance of poly(styrene-co-divinylbenzene) functionalized with different aminophosphonate pendant groups, in the removal of phenolic compounds from aqueous solutions, PURE AND APPLIED CHEMISTRY, Volume: 88, Issue: 10-11, Pages: 993-1004, ISSN: 0033-4545, eISSN: 1365-3075, 2016;
4. Maranescu, B., Lupa, L., Visa, A. Synthesis, characterizations and Pb(II) sorption properties of cobalt phosphonate materials, PURE AND APPLIED CHEMISTRY, Volume: 88, Issue: 10-11, Pages: 979-992, ISSN: 0033-4545, eISSN: 1365-3075, 2016;
5. Motoc, S., Manea, F., Iacob, A., Martinez-Joaristi, A., Gascon, J., Pop, A., Schoonman, J. Electrochemical Selective and Simultaneous Detection of Diclofenac and Ibuprofen in Aqueous Solution Using HKUST-1 Metal-Organic Framework-Carbon Nanofiber Composite Electrode, SENSORS, Volume: 16, Issue: 10, Article Number: 1719, ISSN: 1424-8220, 2016;
6. Petrovic, A., Lelea, D., Laza, I. The comparative analysis on using the NEPCM materials and nanofluids for microchannel cooling solutions, INTERNATIONAL COMMUNICATIONS IN HEAT AND MASS TRANSFER, Volume: 79, Pages: 39-45, ISSN: 0735-1933, eISSN: 1879-0178, 2016;
7. Sarbu, I. A Study of Energy Optimisation of Urban Water Distribution Systems Using Potential Elements, WATER, Volume: 8, Issue: 12, Article Number: 593, ISSN: 2073-4441, 2016;
8. Tigan, G., Constantinescu, D. Bifurcations in a family of Hamiltonian systems and associated nontwist cubic maps, CHAOS SOLITONS & FRACTALS, Volume: 91, Pages: 128-135, ISSN: 0960-0779, eISSN: 1873-2887, 2016;
9. Ancuti, C.O., Ancuti, C., De Vleeschouwer, C., Bovik, A.C. Single-Scale Fusion: An Effective Approach to Merging Images, IEEE TRANSACTIONS ON IMAGE PROCESSING, Volume: 26, Issue: 1, Pages: 65-78, PubMed ID: 27810821, ISSN: 1057-7149, eISSN: 1941-0042, 2017;
10. Banica, R., Ursu, D., Nyari, T., Kellenberger, A. Two step polyol-solvothermal growth of thick silver nanowires, MATERIALS LETTERS, Volume: 194, Pages: 181-184, ISSN: 0167-577X, eISSN: 1873-4979, 2017;
11. Belega, D., Petri, D. Effect of noise and harmonics on sine-wave frequency estimation by interpolated DFT algorithms based on few observed cycles, SIGNAL PROCESSING, Volume: 140, Pages: 207-218, ISSN: 0165-1684, eISSN: 1879-2677, 2017;
12. Bento, A.J.G., Lupa, N., Megan, M., Silva, C.M. INTEGRAL CONDITIONS FOR NONUNIFORM  $\mu$ -DICHOTOMY ON THE HALF-LINE, DISCRETE AND CONTINUOUS DYNAMICAL SYSTEMS-SERIES B, Volume: 22, Issue: 8, Special Issue: SI, Pages: 3063-3077, ISSN: 1531-3492, eISSN: 1553-524X, 2017;
13. Binzar, T., Lazureanu, C. On the Wold-Type Decompositions for n-Tuples of Commuting Isometric Semigroups, FILOMAT, Volume: 31, Issue: 5, Pages: 1251-1264, ISSN: 0354-5180, 2017;

14. Bistran, D.A., Navon, I.M. Randomized dynamic mode decomposition for nonintrusive reduced order modelling, *INTERNATIONAL JOURNAL FOR NUMERICAL METHODS IN ENGINEERING*, Volume: 112, Issue: 1, Pages: 3–25, ISSN: 0029-5981, eISSN: 1097-0207, 2017;
15. Bistran, D.A., Navon, I.M. The method of dynamic mode decomposition in shallow water and a swirling flow problem, *INTERNATIONAL JOURNAL FOR NUMERICAL METHODS IN FLUIDS*, Volume: 83, Issue: 1, Pages: 73–89, ISSN: 0271-2091, eISSN: 1097-0363, 2017;
16. Bota, C. The approximation of solutions for second order nonlinear oscillators using the polynomial least square method, *JOURNAL OF NON-LINEAR SCIENCES AND APPLICATIONS*, Volume: 10, Issue: 1, Pages: 234–242, ISSN: 2008-1898, eISSN: 2008-1901, 2017;
17. Bota, C., Caruntu, B. ANALYTIC APPROXIMATE SOLUTIONS FOR A CLASS OF VARIABLE ORDER FRACTIONAL DIFFERENTIAL EQUATIONS USING THE POLYNOMIAL LEAST SQUARES METHOD, *FRACTIONAL CALCULUS AND APPLIED ANALYSIS*, Volume: 20, Issue: 4, Pages: 1043–1050, ISSN: 1311-0454, eISSN: 1314-2224, 2017;
18. Bota, C., Caruntu, B. Analytical approximate solutions for quadratic Riccati differential equation of fractional order using the Polynomial Least Squares Method, *CHAOS SOLITONS & FRACTALS*, Volume: 102, Pages: 339–345, ISSN: 0960-0779, eISSN: 1873-2887, 2017;
19. Bota, C., Caruntu, B. Approximate analytical solutions of nonlinear differential equations using the Least Squares Homotopy Perturbation Method, *JOURNAL OF MATHEMATICAL ANALYSIS AND APPLICATIONS*, Volume: 448, Issue: 1, Pages: 401–408, ISSN: 0022-247X, eISSN: 1096-0813, 2017;
20. Bota, C., Caruntu, B., Lazureanu, C. THE LEAST SQUARE HOMOTOPY PERTURBATION METHOD FOR BOUNDARY VALUE PROBLEMS, *APPLIED AND COMPUTATIONAL MATHEMATICS*, Volume: 16, Issue: 1, Pages: 39–47, ISSN: 1683-3511, eISSN: 1683-6154, 2017;
21. Casu, I., Lazureanu, C. Stability and Integrability Aspects for the Maxwell - Bloch Equations with the Rotating Wave Approximation, *REGULAR & CHAOTIC DYNAMICS*, Volume: 22, Issue: 2, Pages: 109–121, ISSN: 1560-3547, eISSN: 1468-4845, 2017;
22. Cebrucean, D., Cebrucean, V., Ionel, I., Spliethoff, H. Performance of two iron-based syngas-fueled chemical looping systems for hydrogen and/or electricity generation combined with carbon capture, *CLEAN TECHNOLOGIES AND ENVIRONMENTAL POLICY*, Volume: 19, Issue: 2, Pages: 451–470, ISSN: 1618-954X, eISSN: 1618-9558, 2017;
23. Cioabla, A.E., Pop, N., Trif-Tordai, G., Calinoiu, D.G. Comparative analysis of agricultural materials influenced by anaerobic fermentation for biogas production in terms of ash melting behavior, *JOURNAL OF THERMAL ANALYSIS AND CALORIMETRY*, Volume: 127, Issue: 1, Pages: 515–523, ISSN: 1388-6150, eISSN: 1588-2926, 2017;
24. Cioca, L.I., Ivascu, L. Risk Indicators and Road Accident Analysis for the Period 2012–2016, *SUSTAINABILITY*, Volume: 9, Issue: 9, Article Number: 1530, ISSN: 2071-1050, 2017;
25. Corici, L.N., Shova, S., Badea, V., Aparaschivei, D., Costisor, O., Cseh, L. Investigations on the photochromic properties of 2,6-bis(5-bromo-2-hydroxybenzylidene)cyclohexanone, *PHOTOCHEMICAL & PHOTOBIOLOGICAL SCIENCES*, Volume: 16, Issue: 6, Pages: 946–953, PubMed ID: 28443924, ISSN: 1474-905X, eISSN: 1474-9092, 2017;
26. Coricovac, D.E., Moaca, E.A., Pinzaru, I., Citu, C., Soica, C., Mihali, C.V., Pacurariu, C., Tutelyan, V.A., Tsatsakis, A., Dehelean, C.A. Biocompatible Colloidal Suspensions Based on Magnetic Iron Oxide Nanoparticles: Synthesis, Characterization and Toxicological Profile, *FRONTIERS IN PHARMACOLOGY*, Volume: 8, Article Number: UNSP 154, PubMed ID: 28400730, ISSN: 1663-9812, 2017;
27. Cornea, O., Andreescu, G.D., Muntean, N., Hulea, D. Bidirectional Power Flow Control in a DC Microgrid Through a Switched-Capacitor Cell Hybrid DC-DC Converter, *IEEE TRANSACTIONS ON INDUSTRIAL ELECTRONICS*, Volume: 64, Issue: 4, Pages: 3012–3022, ISSN: 0278-0046, eISSN: 1557-9948, 2017;
28. De Sabata, A., Matekovits, L., Lipan, O. Band pattern of commensurate modulated periodic structures, *IET MICROWAVES ANTENNAS & PROPAGATION*, Volume: 11, Issue: 9, Pages: 1303–1307, ISSN: 1751-8725, eISSN: 1751-8733, 2017;
29. Dinu, F., Marginean, I., Dubina, D. Experimental testing and numerical modelling of steel moment-frame connections under column loss, *ENGINEERING STRUCTURES*, Volume: 151, Pages: 861–878, ISSN: 0141-0296, eISSN: 1873-7323, 2017;
30. Dogariu, A.I., Dubina, D. STRENGTHENING OF MASONRY SHEAR WALLS BASED ON METAL SOLUTIONS. PART I: EXPERIMENTAL INVESTIGATION, *PROCEEDINGS OF THE ROMANIAN ACADEMY SERIES A-MATHEMATICS PHYSICS TECHNICAL SCIENCES INFORMATION SCIENCE*, Volume: 18, Issue: 1, Pages: 81–88, ISSN: 1454-9069, 2017;

31. Dogariu, A.I., Dubina, D. STRENGTHENING OF MASONRY SHEAR WALLS BASED ON METAL SOLUTIONS. PART II: FE-MODEL FOR THE PERFORMANCE EVALUATION, PROCEEDINGS OF THE ROMANIAN ACADEMY SERIES A-MATHEMATICS PHYSICS TECHNICAL SCIENCES INFORMATION SCIENCE, Volume: 18, Issue: 2, Pages: 158-165, ISSN: 1454-9069, 2017;
32. Dumitru, R., Manea, F., Lupa, L., Pacurariu, C., Ianculescu, A., Baci, A., Negrea, S. Synthesis, characterization of nanosized CoAl<sub>2</sub>O<sub>4</sub> and its electrocatalytic activity for enhanced sensing application, JOURNAL OF THERMAL ANALYSIS AND CALORIMETRY, Volume: 128, Issue: 3, Pages: 1305-1312, ISSN: 1388-6150, eISSN: 1588-2926, 2017;
33. Feniser, C., Burz, G., Mocan, M., Ivascu, L., Gherhes, V., Otel, C.C. The Evaluation and Application of the TRIZ Method for Increasing Eco-Innovative Levels in SMEs, SUSTAINABILITY, Volume: 9, Issue: 7, Article Number: 1125, ISSN: 2071-1050, 2017;
34. Filip, I., Szeidert, I. Tuning the control penalty factor of a minimum variance adaptive controller, EUROPEAN JOURNAL OF CONTROL, Volume: 37, Pages: 16-26, ISSN: 0947-3580, eISSN: 1435-5671, 2017;
35. Filippov, S.N., Magadov, K.Y., Jivulescu, M.A. Absolutely separating quantum maps and channels, NEW JOURNAL OF PHYSICS, Volume: 19, Article Number: 083010, ISSN: 1367-2630, 2017;
36. Filip-Vacarescu, N., Vulcu, C., Dubina, D. NUMERICAL STUDY OF A HYBRID DAMPING SYSTEM COMPOSED OF A BUCKLING RESTRAINED BRACE WITH A MAGNETO RHEOLOGICAL DAMPER, PROCEEDINGS OF THE ROMANIAN ACADEMY SERIES A-MATHEMATICS PHYSICS TECHNICAL SCIENCES INFORMATION SCIENCE, Volume: 18, Issue: 3, Pages: 273-280, ISSN: 1454-9069, 2017;
37. Gabor, A., Davidescu, C.M., Negrea, A., Ciopec, M., Muntean, C., Negrea, P., Ianas, C., Butnariu, M. Magnesium silicate doped with environmentally friendly extractants used for rare earth elements adsorption, DESALINATION AND WATER TREATMENT, Volume: 63, Pages: 124-134, ISSN: 1944-3994, eISSN: 1944-3986, 2017;
38. Gheju, M., Balcu, I. Assisted green remediation of chromium pollution, JOURNAL OF ENVIRONMENTAL MANAGEMENT, Volume: 203, Special Issue: SI, Pages: 920-924, Part: 3, PubMed ID: 28479231, ISSN: 0301-4797, eISSN: 1095-8630, 2017;
39. Gheju, M., Balcu, I., Enache, A., Flueraș, A. A kinetic approach on hexavalent chromium removal with metallic iron, JOURNAL OF ENVIRONMENTAL MANAGEMENT, Volume: 203, Special Issue: SI, Pages: 937-941, Part: 3, PubMed ID: 28318824, ISSN: 0301-4797, eISSN: 1095-8630, 2017;
40. Grigorie, A.C., Muntean, C., Vlase, T., Locovei, C., Stefanescu, M. ZnO-SiO<sub>2</sub> based nanocomposites prepared by a modified sol-gel method, MATERIALS CHEMISTRY AND PHYSICS, Volume: 186, Pages: 399-406, ISSN: 0254-0584, eISSN: 1879-3312, 2017;
41. Ianos, R., Babuta, R., Pacurariu, C., Lazau, R., Istratie, R., Butaciu, C. Combustion synthesis of ZnAl<sub>2</sub>O<sub>4</sub> powders with tuned surface area, CERAMICS INTERNATIONAL, Volume: 43, Issue: 12, Pages: 8975-8981, ISSN: 0272-8842, eISSN: 1873-3956, 2017;
42. Ianos, R., Muntean, E., Babuta, R., Lazau, R., Pacurariu, C., Bandas, C. Combustion synthesis of pink chromium-doped alumina with excellent near-infrared reflective properties, CERAMICS INTERNATIONAL, Volume: 43, Issue: 2, Pages: 2568-2572, ISSN: 0272-8842, eISSN: 1873-3956, 2017;
43. Ianos, R., Muntean, E., Pacurariu, C., Lazau, R., Bandas, C., Delinescu, G. Combustion synthesis of a blue Co-doped zinc aluminate near-infrared reflective pigment, DYES AND PIGMENTS, Volume: 142, Pages: 24-31, ISSN: 0143-7208, eISSN: 1873-3743, 2017;
44. Istratie, R., Babuta, R., Popa, A., Pacurariu, C., Stoia, M. Enhanced Adsorption of p-Nitrophenol from Aqueous Solutions Using a Functionalized Styrene-Divinylbenzene Copolymer, WATER AIR AND SOIL POLLUTION, Volume: 228, Issue: 8, Article Number: 276, ISSN: 0049-6979, eISSN: 1573-2932, 2017;
45. Jivulescu, M.A., Nechita, I., Gavruta, P. On symmetric decompositions of positive operators, JOURNAL OF PHYSICS A-MATHEMATICAL AND THEORETICAL, Volume: 50, Issue: 16, Article Number: 165303, ISSN: 1751-8113, eISSN: 1751-8121, 2017;
46. Lazureanu, C. The Real-Valued Maxwell-Bloch Equations with Controls: From a Hamilton-Poisson System to a Chaotic One, INTERNATIONAL JOURNAL OF BIFURCATION AND CHAOS, Volume: 27, Issue: 9, Article Number: 1750143, ISSN: 0218-1274, eISSN: 1793-6551, 2017;
47. Linul, E., Marsavina, L., Kovacic, J. Collapse mechanisms of metal foam matrix composites under static and dynamic loading conditions, MATERIALS SCIENCE AND ENGINEERING A-STRUCTURAL MATERIALS PROPERTIES MICROSTRUCTURE AND PROCESSING, Volume: 690, Pages: 214-224, ISSN: 0921-5093, eISSN: 1873-4936, 2017;



48. Linul, E., Movahedi, N., Marsavina, L. The temperature effect on the axial quasi-static compressive behavior of ex-situ aluminum foam-filled tubes, *COMPOSITE STRUCTURES*, Volume: 180, Pages: 709-722, ISSN: 0263-8223, eISSN: 1879-1085, 2017;
49. Linul, E., Serban, D.A., Marsavina, L., Kovacik, J. Low-cycle fatigue behaviour of ductile closed-cell aluminium alloy foam, *FATIGUE & FRACTURE OF ENGINEERING MATERIALS & STRUCTURES*, Volume: 40, Issue: 4, Pages: 597-604, ISSN: 8756-758X, eISSN: 1460-2695, 2017;
50. Linul, E., Serban, D.A., Marsavina, L., Sadowski, T. Assessment of collapse diagrams of rigid polyurethane foams under dynamic loading conditions, *ARCHIVES OF CIVIL AND MECHANICAL ENGINEERING*, Volume: 17, Issue: 3, Pages: 457-466, ISSN: 1644-9665, eISSN: 2083-3318, 2017;
51. Madescu, G., Biriescu, M., Tutelea, L.N., Mot, M., Svoboda, M., Boldea, I. Experimental Investigation of Rotor Currents Distribution in the Healthy and Faulty Cage of Induction Motors at Standstill, *IEEE TRANSACTIONS ON INDUSTRIAL ELECTRONICS*, Volume: 64, Issue: 7, Pages: 5305-5313, ISSN: 0278-0046, eISSN: 1557-9948, 2017;
52. Marinica, O.M. Study of Static Magnetic Properties of Transformer Oil Based Magnetic Fluids for Various Technical Applications Using Demagnetizing Field Correction, *JOURNAL OF NANOMATERIALS*, Article Number: 5407679, ISSN: 1687-4110, eISSN: 1687-4129, 2017;
53. Marsavina, L., Berto, F., Negru, R., Serban, D.A., Linul, E. An engineering approach to predict mixed mode fracture of PUR foams based on ASED and micromechanical modelling, *THEORETICAL AND APPLIED FRACTURE MECHANICS*, Volume: 91, Special Issue: SI, Pages: 148-154, ISSN: 0167-8442, eISSN: 1872-7638, 2017;
54. Mazilescu, C.A., Gangloff, B. Value Assigned to Employees Who Preserve the Social and Organizational Environment, *SUSTAINABILITY*, Volume: 9, Issue: 2, Article Number: 170, ISSN: 2071-1050, 2017;
55. Micea, M.V., Stangaciu, C.S., Stangaciu, V., Curiac, D.I. Novel Hybrid Scheduling Technique for Sensor Nodes with Mixed Criticality Tasks, *SENSORS*, Volume: 17, Issue: 7, Article Number: 1504, ISSN: 1424-8220, 2017;
56. Mihaicuta, S., Udrescu, M., Topirceanu, A., Udrescu, L. Network science meets respiratory medicine for OSAS phenotyping and severity prediction, *PEERJ*, Volume: 5, Article Number: e3289, PubMed ID: 28503375, ISSN: 2167-8359, 2017;
57. Moro, A.J., Parola, A.J., Pina, F., Pana, A.M., Badea, V., Pausescu, I., Shova, S., Cseh, L. 2,2'-Spirobis[chromene] Derivatives Chemistry and Their Relation with the Multistate System of Anthocyanins, *JOURNAL OF ORGANIC CHEMISTRY*, Volume: 82, Issue: 10, Pages: 5301-5309, PubMed ID: 28441475, ISSN: 0022-3263, 2017;
58. Movahedi, N., Linul, E. Quasi-static compressive behavior of the ex-situ aluminum-alloy foam-filled tubes under elevated temperature conditions, *MATERIALS LETTERS*, Volume: 206, Pages: 182-184, ISSN: 0167-577X, eISSN: 1873-4979, 2017;
59. Nanu, S., Ionel, R., Dughir, C., Ionel, I. Automation of a prototype for cutting, sorting and bundling of SRC crops for planting purposes, *MEASUREMENT*, Volume: 95, Pages: 201-209, ISSN: 0263-2241, eISSN: 1873-412X, 2017;
60. Niyonzima, S., Ilie, S., Pop, N., Mezei, J.Z., Chakrabarti, K., Morel, V., Peres, B., Little, D.A., Hassouni, K., Larson, A., Orel, A.E., Benredjem, D., Bultel, A., Tennyson, J., Reiter, D., Schneider, I.F. Low-energy collisions between electrons and BeH<sup>+</sup>: Cross sections and rate coefficients for all the vibrational states of the ion, *ATOMIC DATA AND NUCLEAR DATA TABLES*, Volume: 115, Pages: 287-308, ISSN: 0092-640X, eISSN: 1090-2090, 2017;
61. Oncioiu, I., Petrescu, A.G., Grecu, E., Petrescu, M. Optimizing the Renewable Energy Potential: Myth or Future Trend in Romania, *ENERGIES*, Volume: 10, Issue: 6, ISSN: 1996-1073, 2017;
62. Osaci, M., Cacciola, M. Study about the nanoparticle agglomeration in a magnetic nanofluid by the Langevin dynamics simulation model using an effective Verlet-type algorithm, *MICROFLUIDICS AND NANOFUIDICS*, Volume: 21, Issue: 2, Article Number: 19, ISSN: 1613-4982, eISSN: 1613-4990, 2017;
63. Pacurariu, C., Lazau, I., Lazau, R. Kinetic studies of the dehydroxylation and crystallization of raw kaolinite and fluorides-modified kaolinite, *JOURNAL OF THERMAL ANALYSIS AND CALORIMETRY*, Volume: 127, Issue: 1, Pages: 239-246, ISSN: 1388-6150, eISSN: 1588-2926, 2017;
64. Pater, F. SOME INEQUALITIES ON POWER BOUNDED OPERATORS ACTING ON LOCALLY CONVEX SPACES, *JOURNAL OF MATHEMATICAL INEQUALITIES*, Volume: 11, Issue: 2, Pages: 485-494, ISSN: 1846-579X, 2017;
65. Pop, A., Manea, F., Flueraș, A., Schoonman, J. Simultaneous Voltammetric Detection of Carbaryl and Paraquat Pesticides on Graphene-Modified Boron-Doped Diamond Electrode, *SENSORS*, Volume: 17, Issue: 9, Article Number: 2033, ISSN: 1424-8220, 2017;



66. Popa, S., Iliescu, S., Iliă, G., Plesu, N., Popa, A., Visa, A., Macarie, L. Solid polymer electrolytes based on phosphorus containing polymers for lithium polymer batteries, *EUROPEAN POLYMER JOURNAL*, Volume: 94, Pages: 286-298, ISSN: 0014-3057, eISSN: 1873-1945, 2017;
67. Pozna, C., Precup, R.E. On a translated frame-based approach to geometric modeling of robots, *ROBOTICS AND AUTONOMOUS SYSTEMS*, Volume: 91, Pages: 49-58, ISSN: 0921-8890, eISSN: 1872-793X, 2017;
68. Precup, R.E., David, R.C., Petriu, E.M. Grey Wolf Optimizer Algorithm-Based Tuning of Fuzzy Control Systems With Reduced Parametric Sensitivity, *IEEE TRANSACTIONS ON INDUSTRIAL ELECTRONICS*, Volume: 64, Issue: 1, Pages: 527-534, ISSN: 0278-0046, eISSN: 1557-9948, 2017;
69. Precup, R.E., Radac, M.B., Roman, R.C., Petriu, E.M. Model-free sliding mode control of nonlinear systems: Algorithms and experiments, *INFORMATION SCIENCES*, Volume: 381, Pages: 176-192, ISSN: 0020-0255, eISSN: 1872-6291, 2017;
70. Radac, M.B., Precup, R.E., Roman, R.C. Model-Free control performance improvement using virtual reference feedback tuning and reinforcement Q-learning, *INTERNATIONAL JOURNAL OF SYSTEMS SCIENCE*, Volume: 48, Issue: 5, Pages: 1071-1083, ISSN: 0020-7721, eISSN: 1464-5319, 2017;
71. Stefan, D., Rudolf, P., Muntean, S., Susan-Resiga, R. Proper Orthogonal Decomposition of Self-Induced Instabilities in Decelerated Swirling Flows and Their Mitigation Through Axial Water Injection, *JOURNAL OF FLUIDS ENGINEERING-TRANSACTIONS OF THE ASME*, Volume: 139, Issue: 8, Article Number: 081101, ISSN: 0098-2202, eISSN: 1528-901X, 2017;
72. Stoia, M., Muntean, C., Militaru, B. MnFe2O4 nanoparticles as new catalyst for oxidative degradation of phenol by peroxydisulfate, *JOURNAL OF ENVIRONMENTAL SCIENCES*, Volume: 53, Pages: 269-277, PubMed ID: 28372751, ISSN: 1001-0742, eISSN: 1878-7320, 2017;
73. Stoia, M., Muntean, E., Pacurariu, C., Mihali, C. Thermal behavior of MnFe2O4 and MnFe2O4/C nanocomposite synthesized by a solvothermal method, *THERMOCHIMICA ACTA*, Volume: 652, Pages: 1-8, ISSN: 0040-6031, eISSN: 1872-762X, 2017;
74. Stoia, M., Pacurariu, C., Muntean, E.C., Thermal stability of the solvothermal-synthesized MnFe2O4 nanopowder, *JOURNAL OF THERMAL ANALYSIS AND CALORIMETRY*, Volume: 127, Issue: 1, Pages: 155-162, ISSN: 1388-6150, eISSN: 1588-2926, 2017;
75. Tigan, G. DEGENERATE WITH RESPECT TO PARAMETERS FOLD-HOPF BIFURCATIONS, *DISCRETE AND CONTINUOUS DYNAMICAL SYSTEMS*, Volume: 37, Issue: 4, Pages: 2115-2140, ISSN: 1078-0947, eISSN: 1553-5231, 2017;
76. Tigan, G. Using Melnikov functions of any order for studying limit cycles, *JOURNAL OF MATHEMATICAL ANALYSIS AND APPLICATIONS*, Volume: 448, Issue: 1, Pages: 409-420, ISSN: 0022-247X, eISSN: 1096-0813, 2017;
77. Tigan, G., Llibre, J., Ciurdariu, L. Degenerate Fold-Hopf Bifurcations in a Rossler-Type System, *INTERNATIONAL JOURNAL OF BIFURCATION AND CHAOS*, Volume: 27, Issue: 5, Article Number: 1750068, ISSN: 0218-1274, eISSN: 1793-6551, 2017;
78. Tiwari, A.K., Albulescu, C.T., Yoon, S.M. A multifractal detrended fluctuation analysis of financial market efficiency: Comparison using Dow Jones sector ETF indices, *PHYSICA A-STATISTICAL MECHANICS AND ITS APPLICATIONS*, Volume: 483, Pages: 182-192, ISSN: 0378-4371, eISSN: 1873-2119, 2017;
79. Topirceanu, A. Breaking up friendships in exams: A case study for minimizing student cheating in higher education using social network analysis, *COMPUTERS & EDUCATION*, Volume: 115, Pages: 171-187, ISSN: 0360-1315, eISSN: 1873-782X, 2017;
80. Topirceanu, A., Udrescu, M. Statistical fidelity: a tool to quantify the similarity between multi-variable entities with application in complex networks, *INTERNATIONAL JOURNAL OF COMPUTER MATHEMATICS*, Volume: 94, Issue: 9, Pages: 1787-1805, ISSN: 0020-7160, eISSN: 1029-0265, 2017;
81. Totorean, A.F., Hudrea, C.I., Bosioc, A.I., Bernad, S.I. FLOW FIELD EVOLUTION IN STENTED VERSUS STENOSED CORONARY ARTERY, *PROCEEDINGS OF THE ROMANIAN ACADEMY SERIES A-MATHEMATICS PHYSICS TECHNICAL SCIENCES INFORMATION SCIENCE*, Volume: 18, Issue: 3, Pages: 248-255, ISSN: 1454-9069, 2017;
82. Tudoran, R.M., Girban, A. Bifurcations of limit cycles of perturbed completely integrable systems, *NONLINEARITY*, Volume: 30, Issue: 3, Pages: 1058-1088, ISSN: 0951-7715, eISSN: 1361-6544, 2017;
83. Ungureanu, L., Carstoiu, G., Micea, M.V., Groza, V. Battery state of health estimation: a structured review of models, methods and commercial devices, *INTERNATIONAL JOURNAL OF ENERGY RESEARCH*, Volume: 41, Issue: 2, Pages: 151-181, ISSN: 0363-907X, eISSN: 1099-114X, 2017;

84. Vlazan, P., Stoia, M., Poienar, M., Sfirloaga, P. Phase transition behaviour and physicochemical properties of KNbO<sub>3</sub> ceramics, CERAMICS INTERNATIONAL, Volume: 43, Issue: 8, Pages: 5963-5967, ISSN: 0272-8842, eISSN: 1873-3956, 2017;
85. Vulcu, C., Stratan, A., Ciutina, A., Dubina, D. Beam-to-CFT High-Strength Joints with External Diaphragm. I: Design and Experimental Validation, JOURNAL OF STRUCTURAL ENGINEERING, Volume: 143, Issue: 5, Article Number: 04017001, ISSN: 0733-9445, eISSN: 1943-541X, 2017;
86. Vulcu, C., Stratan, A., Ciutina, A., Dubina, D. Beam-to-CFT High-Strength Joints with External Diaphragm. II: Numerical Simulation of Joint Behavior, JOURNAL OF STRUCTURAL ENGINEERING, Volume: 143, Issue: 5, Article Number: 04017002, ISSN: 0733-9445, eISSN: 1943-541X, 2017.

## EXECUTIVE UNIT FOR FINANCING HIGHER EDUCATION, RESEARCH, DEVELOPMENT AND INNOVATION - UEFISCDI AWARDS - GRANTED PATENTS

1. Pinca-Bretotean, C. Installation for Determining Thermal Endurance, OSIM, RO 126966 B1, 30.03.2016;
2. Gheju, M.T., Pode, R., Iovi, A., Balcu, I., Coheci, L., Ciopec, M.E. Process for Removal of Hexavalent Chrome from Waste Water, OSIM, RO 127099 B1, 30.09.2016;
3. Negrea, A.G., Lazau, I., Lupa, L.A., Lazau, R.I., Ciopec, M.E. Process for Removing Arsenic from Water and Immobilizing the Resulting Waste in Vitreous Matrices, OSIM, RO 127098 B1, 30.01.2017;
4. Susan-Resiga, R.F., Tanasa, C., Bosioc, A.I., Ciocan, T., Stuparu, A.C., Muntean, S. Method and Equipment for Controlling the Swirling Flow Through the Conical Diffuser of Hydraulic Turbines, OSIM, RO 130075 B1, 28.04.2017;



# PROJECTS SUPPORTED BY PUBLIC FUNDS



# National Research Projects





## PROJECTS SUPPORTED BY NATIONAL PUBLIC FUNDS IMPLEMENTED BY PUT 2017

Fields	Total number of projects	Number of projects presented
Socio-economic and humanist research	4	2
Bioeconomy	1	1
Eco-Nano-Tehnologies and advanced materials	2	2
Energy, environment and climatic changes	19	14
Mathematics and Informatics	3	1
Physics	1	-
Materials, Processes and Innovative Products	3	3
Microwave, Antennas and Propagation, Electromagnetic Compatibility, Metamaterials	1	-
Health	1	-
Materials science	2	1
Engineering science	31	7
Applied Life Sciences and Biotechnologies	3	3
Information and Communication Technology, Space and Security	12	10
<b>Total</b>	<b>83</b>	<b>44</b>



## EVOLUTION OF PROJECTS SUPPORTED BY NATIONAL PUBLIC FUNDS IMPLEMENTED BY PUT 2013 - 2017

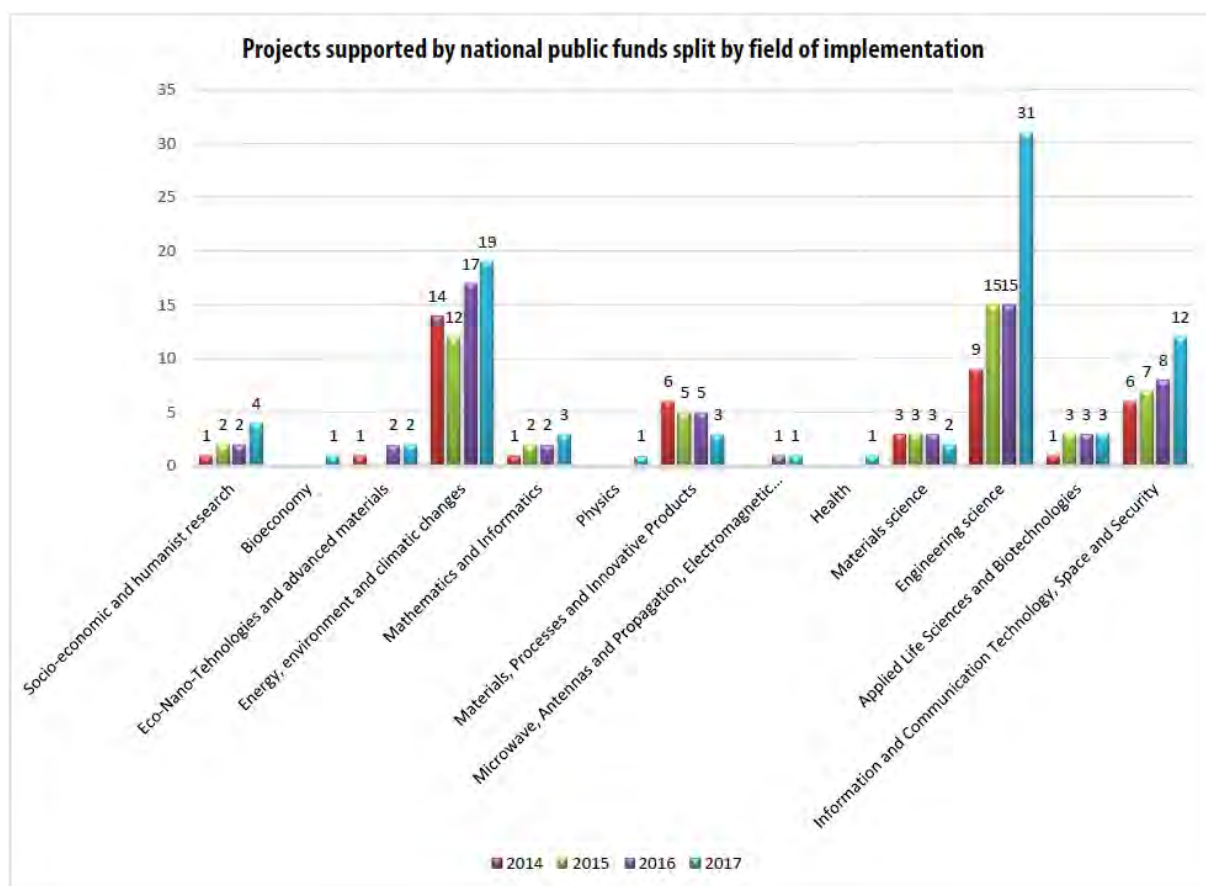
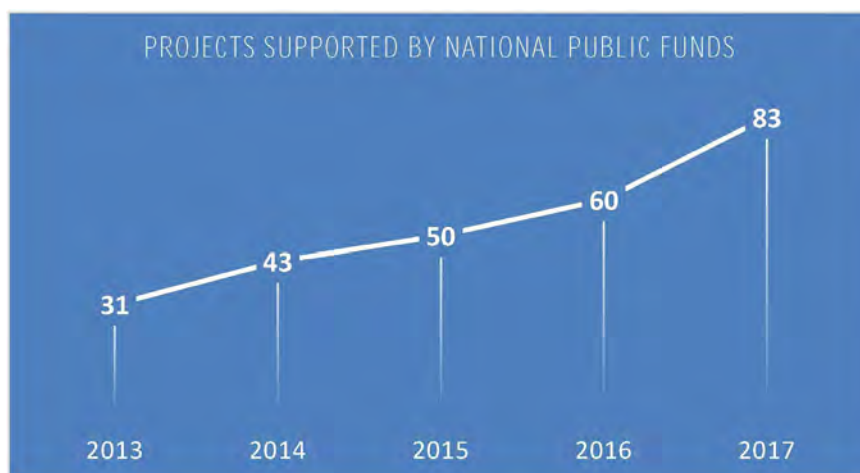



## NEW PERFORMANCE IMPROVEMENT TECHNIQUES OF CONTROL SYSTEMS USING EXPERIMENT-BASED TUNING

### Goal of the project

- Development of advanced control structures for automotive and mechatronics applications.
- Improvement and development of new Takagi-Sugeno (T-S) fuzzy models and control solutions for a wide range of industrial processes, mechatronics, mobile robots and automotive applications.
- Optimal tuning of fuzzy models for automotive and mechatronics applications.
- Improvement and development of control algorithms for mobile robots.

### Short description of the project

Advanced control structures and optimal tuning of fuzzy models for a wide range of industrial processes are offered.

### Project implemented by

Department of Automation and Applied Informatics of UPT as the P2 partner, coordinator: University of Craiova, P1 partner: Moara Calafatului, P3 partner: "Lower Danube" University of Galati, director: Prof. Dr. Eng. Dan Selisteanu (University of Craiova).

### Implementation period

2014-2017

### Main activities

- Development and experimental validation of simple T-S fuzzy models, evolving fuzzy models and advanced controllers (2-DOF, predictive and fuzzy) for processes in automotive and mechatronics: anti-lock braking systems, nonlinear DC drive servo systems, magnetic levitation systems.
- Continuous development of the nRobotic platform for path planning and collision avoidance of mobile robots in missions.
- Modeling, simulation, analysis and development of: T-S PD + I fuzzy controllers, 2-DOF linear and fuzzy controllers, hybrid T-S fuzzy controllers for speed and position control of brushless DC drives with variable parameters and inputs.
- Optimal tuning of parameters of T-S fuzzy models using nature-inspired algorithms: charged system search, grey wolf optimization, gravitational search algorithms.

### Results

Results in 2017:

- 2 papers published in Clarivate Analytics Web of Science (WoS) journals with impact factors.
- 2 papers published in conference proceedings indexed in WoS.
- 2 papers published in conference proceedings indexed in international databases.
- More than 50 independent citations in 2017.

### Applicability and transferability of the results

- Nature-inspired evolutionary-based optimization algorithms in modeling and control design.
- Cost-effective solutions for control problems in mechatronics, electrical drives, automotive and robotics.
- Tools for the modeling, optimization and design of fuzzy control systems.
- Real-time programming and operating systems for control and robotics.

### Financed through/by

Executive Agency for Higher Education, Research, Development and Innovation Funding (UEFISCDI), Bucharest, Romania.

### Research Centre

Automatic Systems Engineering Research Centre (CCISA).  
<http://www.aut.upt.ro/centru-cercetare/index.EN.php>

Effect of centroid update approach applied to first dataset



Number of centroid updates applied to every centroid of first dataset

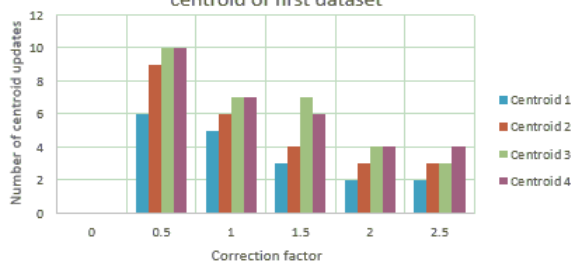

$J_{l,init}$

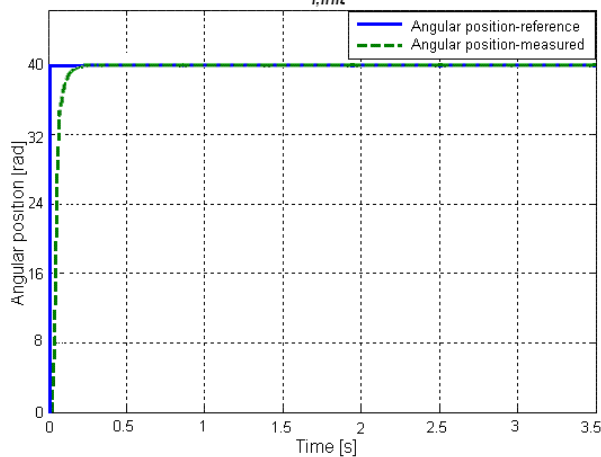

$J_{l,avg}$

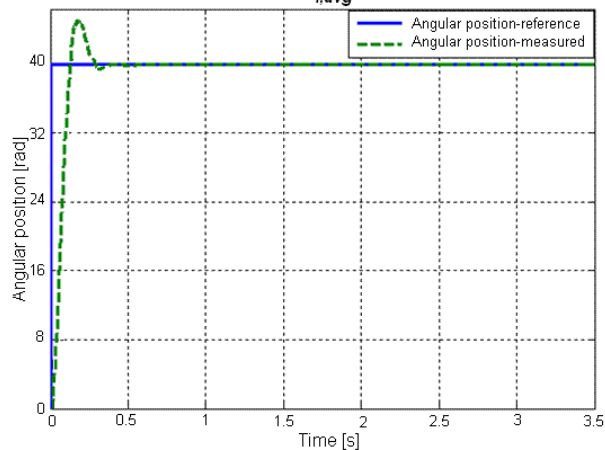

## Research team

Prof. Dr. Eng. Radu-Emil Precup,  
 Prof. Dr. Eng. Stefan Preitl,  
 Prof. Dr. Eng. Ioan Filip,  
 Assoc. Prof. Dr. Eng. Florin Drăgan,  
 Lect. Dr. Eng. Adriana Albu,  
 Lect. Dr. Eng. Ovidiu Baniș, Lect. Dr. Eng. Daniel Iercan,  
 Lect. Dr. Eng. Mircea-Bogdan Rădac,  
 Lect. Dr. Eng. Claudia-Adina Bojan-Dragoș,  
 Assist. Lect. Dr. Eng. Alexandra-Iulia Szedlak-Stînean,  
 PhD student Eng. Emil-Ioan Voişan,  
 PhD student M.Sc. Eng. Lucian-Ovidiu Fedorovici.

## Contact information

Prof. Radu-Emil PRECUP, PhD  
 Politehnica University of Timisoara,  
 Department of Automation and Applied Informatics,  
 Bd. V. Parvan 2, 300223 Timisoara, Romania  
 Phone: (+40) 256 403229  
 Fax: (+40) 256 403214  
 E-mail: radu.precup@upt.ro  
<http://www.aut.upt.ro/~rprecup/>

## ADVANCED CONTROL SYSTEM OF A BIOREFINERY PLANT (BIOCON)

### Goal of the project

- Enhancement and development of data-based (data-driven) techniques and algorithms for improving control system performances using experimental data.
- Enhancement and development of nature-inspired algorithms in optimization of control system performance.
- Development of optical character recognition (OCR) applications.
- Development of new fuzzy control solutions for a wide range of industrial processes.

### Short description of the project

Enhance existing techniques, develop new ones for data-based control system performance improvement.

### Project implemented by

Department of Automation and Applied Informatics of UPT as the P2 partner, coordinator: "Lower Danube" University of Galati, P1 partner: University of Craiova, P3 partner: S.C. Teamnet Engineering S.R.L – Galati, director: Prof. Dr. Eng. Sergiu Caraman ("Lower Danube" University of Galati).

### Implementation period

2014-2017

### Main activities

- Application of Iterative Feedback Tuning (IFT) to controller tuning for nonlinear control systems.
- Model-Free Adaptive Control strategies applied to aerodynamic systems.
- An experiment-based approach to Reference Trajectory Tracking optimal control problem with constraints.
- Validation of iterative techniques on laboratory equipment: liquid level control, motion control systems with motor actuation (speed and position control).
- Enhancement of control systems performance by fuzzy control, IFT and nature-inspired optimization algorithms.
- PI and fuzzy controller tuning to ensure a reduced process parametric sensitivity.
- Improve the training algorithm of Convolutional Neural Networks using mixed Back-Propagation and nature-inspired optimization algorithms.

### Results

Results in 2017:

- 2 papers published in Clarivate Analytics Web of Science (WoS) journals with impact factors.
- 2 papers published in conference proceedings indexed in WoS.
- 2 papers published in conference proceedings indexed in international databases.
- More than 30 independent citations in 2017.

### Applicability and transferability of the results

- Control systems with a reduced parametric sensitivity.
- Tools for the computer-aided design of controllers.
- Computer-aided techniques in iterative data-based control.
- Nature-inspired optimization algorithms in control design and image processing.
- Tools for the systematic development of fuzzy control systems.

### Financed through/by

Executive Agency for Higher Education, Research, Development and Innovation Funding (UEFISCDI), Bucharest, Romania.

### Research Centre

Automatic Systems Engineering Research Centre (CCISA).  
<http://www.aut.upt.ro/centru-cercetare/index.EN.php>

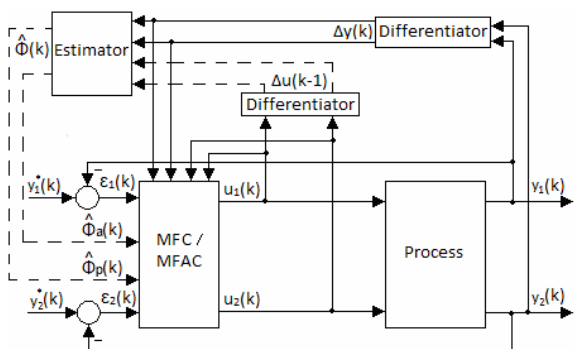
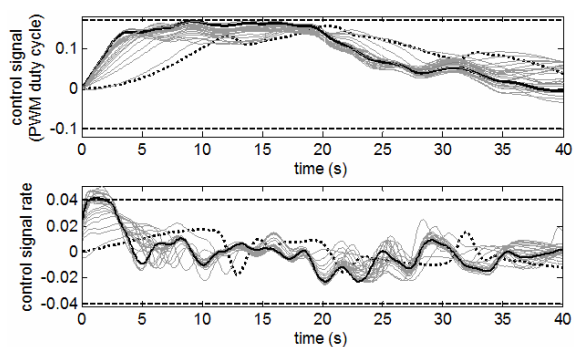
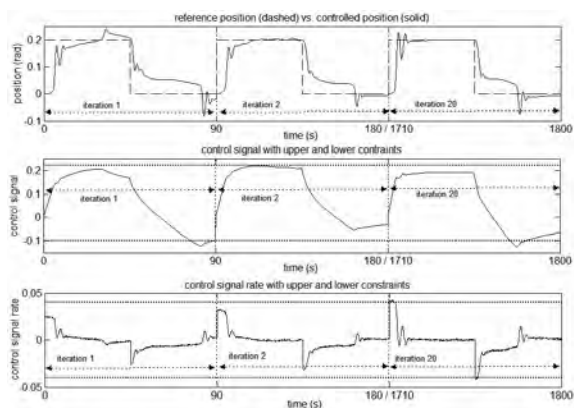

## Research team

Prof. Dr. Ing. Radu-Emil Precup,  
 Prof. Dr. Ing. Stefan Preitl,  
 Assoc. Prof. Dr. Ing. Florin Drăgan,  
 Lect. Dr. Ing. Daniel Iercan,  
 Lect. Dr. Ing. Mircea-Bogdan Rădac,  
 Lect. Dr. Ing. Claudia-Adina Bojan-Dragoș,  
 Assist. Lect. Dr. Ing. Alexandra-Iulia Szedlak-Stînean,  
 PhD student Eng. Emil-Ioan Voișan,  
 PhD student M.Sc. Dipl. Ing. Lucian-Ovidiu Fedorovici.

## Contact information

Prof. Radu-Emil PRECUP, PhD  
 Politehnica University of Timisoara,  
 Department of Automation and Applied Informatics,  
 Bd. V. Parvan 2, 300223 Timisoara, Romania  
 Phone: (+40) 256 403229  
 Fax: (+40) 256 403214  
 E-mail: radu.precup@upt.ro  
<http://www.aut.upt.ro/~rprecup/>



## CSEAMAN - CRYPTOGRAPHIC SECURITY FOR AUTOMOTIVE EMBEDDED DEVICES AND NETWORKS

### Goal of the project:

The design and analysis of cryptographic security solutions for automotive embedded devices and networks

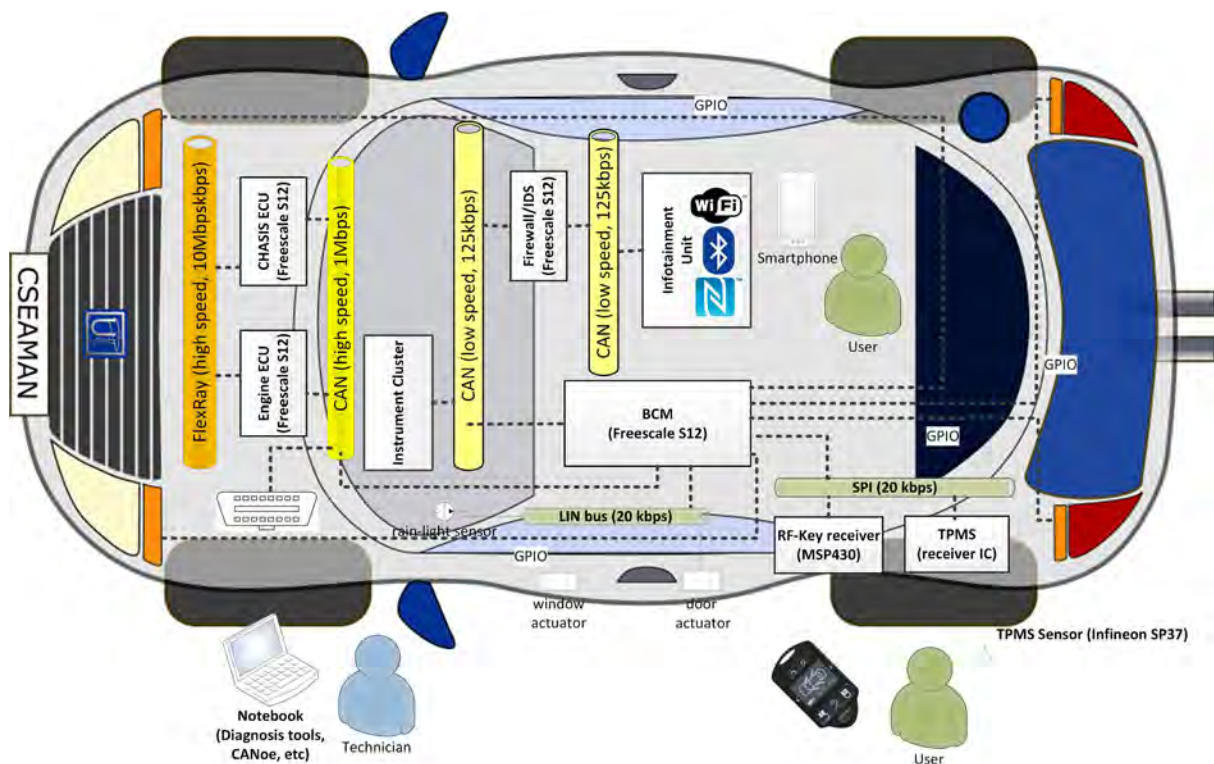

### Short description of the project:

The project aims at the design and analysis of cryptographic security solutions with applications in the automotive domain. Our main challenge is to accommodate cryptographic security on automotive-grade devices with low computational and memory resources that communicate over in-vehicle networks with constrained bandwidth. We focus both on wired and wireless channels that open cars to outsiders and bring a complex adversarial setup. Existing security sub-systems in cars (e.g., wireless keys, TPMS units) are also within reach.

### Project implemented by

Research Group on Embedded Systems and Security, Department of Automation and Applied Informatics, Faculty of Automatics and Computers (UPT)

### Implementation period:

Oct. 2015 – Sept. 2017

## Main activities:

- Implementation and security analysis of cryptographic functions on automotive grade embedded devices, e.g., AUTOSAR compliant cryptographic libraries,
- Design and analysis of cryptographic protocols for wired in-vehicle networks, e.g., CAN bus, J1939, FlexRay, etc.
- Design and analysis of cryptographic protocols for wireless in-vehicle connectivity, e.g., RF keys, TPMS systems, etc.
- Implementation of an experimental platform for security critical subsystems inside the car: communication buses linking various ECUs with potentially insecure third-party devices (e.g. infotainment units)
- Risk analysis and security implications within new automotive paradigms: optimized traffic flows, vehicle-to-vehicle communications, etc.

## Results:

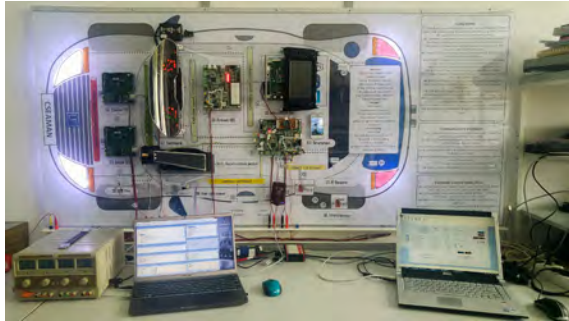

- An experimental model for in-vehicle networks and subsystems
- Comprehensive performance analysis of cryptographic functions on automotive-grade controllers
- Analysis of fingerprinting and randomness extraction mechanism from SRAM state
- Design of new security solutions for wireless vehicle access

- Design of new security solutions for the CAN bus
- Security analysis and fixes for the J1939 commercial-vehicle bus protocol
- Analysis of traffic models with adversarial vehicle behavior
- Risk analysis and security implications for attacks on BCM units and vehicle instrument clusters

## Applicability and transferability of the results:

Various applications in the automotive industry for securing critical vehicular systems and networks, e.g., wireless keys, CAN bus, ECU fingerprinting, etc.

## Financed through/by

Romanian National Authority for Scientific Research and Innovation (CNCS-UEFISCDI) Project No. PN-II-RU-TE-2014-4-1501

## Research team

Habil. PhD. Eng. Bogdan Groza – director  
PhD. Eng. Stefan Murvay (postdoctoral researcher)  
PhD. Eng. Horatiu Gurban (postdoctoral researcher)  
Eng. Catalin Briciu (PhD student)  
Eng. Emanuel Ionascu (PhD student)  
Eng. Tudor Andreica (student)

## Contact information (Ex)

Prof. Bogdan GROZA, PhD.Eng.  
Faculty of Automatics and Computer,  
Bd. V. Parvan, No. 2, 300236, Timisoara  
Phone: (+40) 256 403242  
E-mail: bogdan.groza@aut.upt.ro  
Web: <http://www.aut.upt.ro/~bgroza/projects/cseaman>

## LEARNING TECHNIQUES FOR IMPROVING CONTROL SYSTEMS PERFORMANCE USING MODEL-FREE APPROACHES (LTIPERFORM)

### Goal of the project:

The main objective of this proposal is to develop the necessary tools, algorithms and theoretical framework in order to induce the learning-predictive behavior for control systems using model-free control approaches. Several reference input-controlled output behaviors are memorized as primitive tasks inside a library. The primitives are used in predicting the optimal behavior of the control system when a new complex task is to be executed. A planning mechanism similar to a brain will be built in order to achieve this task.

### Short description of the project:

The proposed techniques endow control systems with learning and planning features.

### Project implemented by

Department of Automation and Applied Informatics of Politehnica University of Timisoara  
<http://mbradac.info/te2015.html>

### Implementation period:

2015-2017

### Main activities:

- Improvement of data-based (or data-driven) techniques and their combination for obtaining improved capabilities.
- Development and validation of a primitive-based learning and planning strategy for feedback control systems.
- Validation of the proposed theoretical approaches on real-world processes such as laboratory equipments.
- Dissemination of research results in highly visible journals and conferences.

### Results:

Results in 2017:

- 3 papers published in Thomson Reuters Web of Science journals with impact factors;
- 6 papers published in conference proceedings (to be) indexed in international databases (ISI, IEEE Xplore, INSPEC, Scopus, DBLP);

### Applicability and transferability of the results:

Owing to the generality of the proposed theoretical framework, the primitive-based learning and planning approach for achieving optimal behavior can be applied to various (feedback) control systems such as mechanical, electrical, chemical, biological, or combinations of the above, in order to enhance them with optimal behavior ability in situations or scenarios never seen before. Thus, they imitate the living organisms. The results also connect several perspectives from the areas of feedback control and machine learning.

### Financed through/by

Executive Agency for Higher Education, Research, Development and Innovation Funding (UEFISCDI), Bucharest, Romania.

### Research Center

Automatic Systems Engineering Research Centre (CCISA)  
<http://www.aut.upt.ro/centru-cercetare/index.EN.php>

### Research team

Lect. Dr. Ing. Mircea-Bogdan Rădac – director, principal investigator,  
Prof. Dr. Ing. Radu-Emil Precup – senior staff member,  
Assist. Lect. Dr. Ing. Alexandra-Iulia Szedlak-Stănean – post doc,  
M.Sc. Dipl. Ing. Raul-Cristian Roman – Ph.D. student,  
M.Sc. Dipl. Ing. Constantin Purcaru – Ph.D. student.

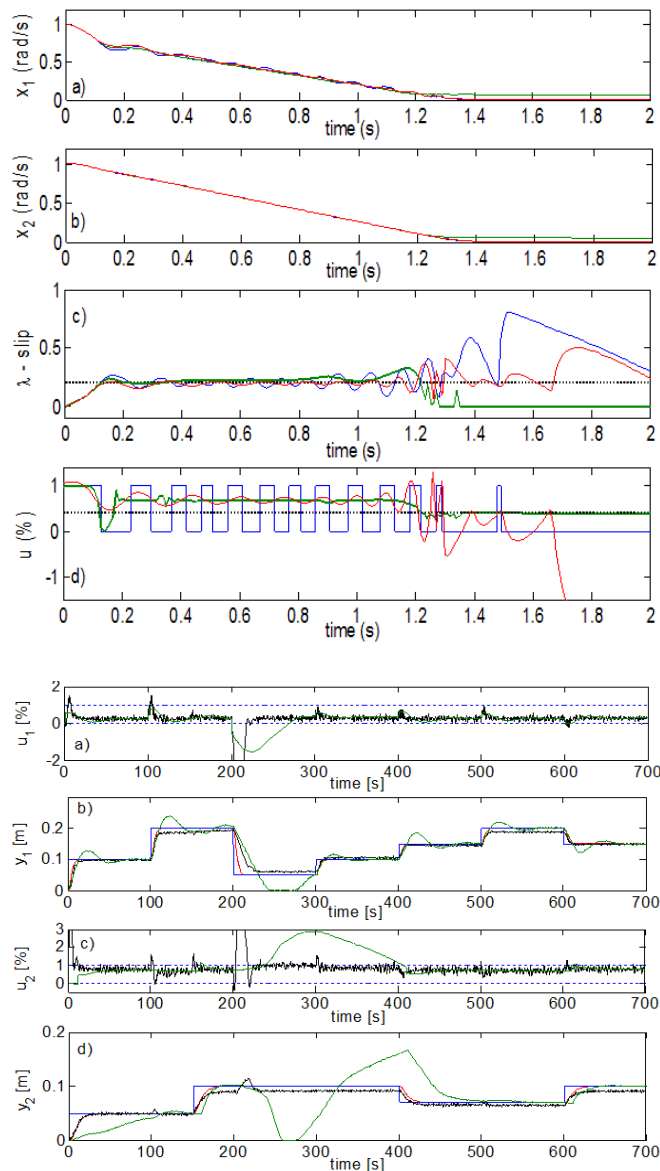

## Contact information

Lect. Mircea-Bogdan RADAC, PhD  
 Politehnica University of Timisoara,  
 Department of Automation and Applied Informatics,  
 Bd. V. Parvan 2, 300223 Timisoara, Romania  
 Phone: (+40) 256 403240  
 Fax: (+40) 256 403214  
 E-mail: mircea.radac@upt.ro  
<http://www.mbradac.info>

## TIME AND ENERGY EFFICIENT FRAMEWORK FOR INTER-OPERATION OF SMART DEVICES (TEEFIOS)

### Goal of the project

Development of an integrated real-time and energy efficient inter-operation framework for networks of smart sensors and devices - TEEFIOS.

### Short description of the project

- Wireless networks of sensors and smart devices (WSN) are an extremely interesting topic, at the confluence of engineering fields with enormous impact on worldwide society: digital networks, wireless communications, and miniature embedded digital devices.
- Aware of the severe requirements and challenges raised by current applications in this area, we propose a new paradigm - Time and Energy Efficiency (T: or TEE).

The main proposed objectives focus on three distinct layers:

- (a) T:Node, a hardware-software environment and methodology for designing and assessing real-time behavior and efficient energy consumption of embedded devices,
- (b) T:YNet, a system for the development and analysis of TEE communication in wireless ad-hoc networks, and
- (c) T:PIlot, a methodology for the power management of the entire network. An integrated set of tools, benchmarks and databases will also be created to help advanced developers and researchers in the WSN area apply the TEE paradigm to applications with high impact.

### Project implemented by

- DSPLabs - Digital Signal Laboratories Timisoara, Department of Computer and Software Engineering, Politehnica University of Timisoara.

### Implementation period

01.10.2015 - 30.09.2017 (24 months)

### Grant value

548850 RON (~123337 EUR)

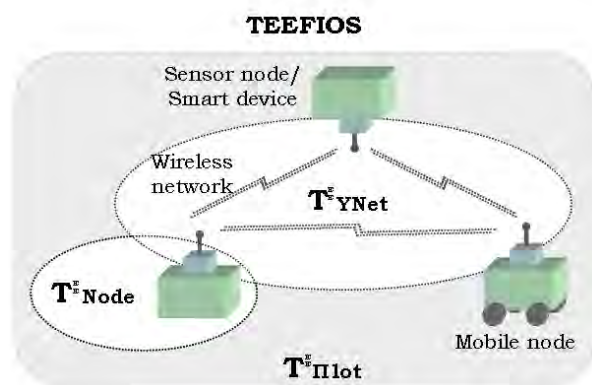

### Main activities

- Energy consumption model and taxonomy for smart devices;
- Energy optimization real-time scheduling mechanism for smart devices;
- Methodology for node-level energy consumption assessment;
- Real-Time MAC protocol for ad-hoc wireless networks;
- Flexible real-time wireless module for smart devices;
- Framework for real-time communication in WSNs;
- Global power management methodology for networks of smart devices;
- Case studies to validate the TEEFIOS framework;
- Integrated set of databases and web-based tools;
- Information exchange, results dissemination and publication.

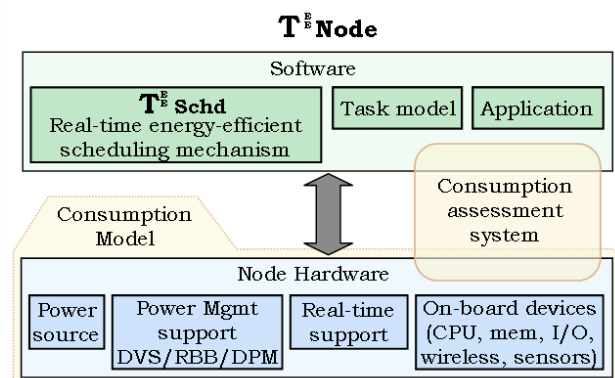

## Results

- Integrated set of consumption models for smart devices;
- T:Schd, a real-time scheduling technique which optimizes energy consumption;
- Hardware/software methodology for the consumption evaluation of smart devices;
- Database with the energy efficiency evaluation and classification results for different types of smart devices;
- Real-time MAC protocol for ad-hoc wireless networks;
- Functional prototype of a flexible real-time wireless module for smart devices;
- A framework and a set of metrics for the evaluation of real-time wireless communication applications;
- A simulation testbed to evaluate the scalability of time and energy efficient WSN applications;
- T:Plot, a global power management methodology for networks of smart devices;
- A collection of case studies that demonstrate the validity of the proposed framework and its individual components;
- An integrated set of web and database tools for public-level information and access to the TEEFIOS framework services.

## Applicability and transferability of the results

- The real-time and energy efficient interoperation framework, along with the associated tool set and databases, will be of valuable use to the advanced developers and researchers in the field of wireless sensor/smart device networks.
- The results of this project will help them apply the TEE paradigm to applications with high impact in scientific, social, economic and environmental areas, such as: disaster recovery, smart buildings and structures, environment monitoring, smart energy grids and metering, robotic collectives, industrial process control, smart vehicles and transportation, security and surveillance.

## Fields of interest

- Real-time systems;
- Energy efficiency;
- Sensors and smart devices;
- Wireless communication;
- Ad-hoc networks.

## Financed through/by

UEFISCDI, Romanian Ministry of Education and Research, Bucharest, Romania.

## Research team

Project director:  
Prof. Dr. Eng. Mihai V. Micea

R&D team:  
Prof. Dr. Eng. Vladimir Cretu,  
A/Prof. Dr. Eng. Dan Pescaru,  
Lect. Dr. Eng. Răzvan Cioargă,  
T/Assist. Dr. Eng. Valentin Stângaciu,  
T/Assist. Dr. Eng. Cristina Stângaciu,  
PhD Stud. Eng. Lucian Ungurean,  
Eng. Claudia Micea,  
Eng. Adriana R. Tirnovan.

## Contact information

Prof. Mihai MICEA, PhD  
Department of Computer Science  
Address: Str. Bd. Vasile Pârvan, No. 2, RO300223, Timisoara,  
Phone: (+40) 256 403271  
Fax: (+40) 256 403214  
E-mail: mihai.micea@upt.ro  
Web: <http://dsplabs.cs.upt.ro/grants/teefios/>



## INTERNET OF THINGS MEETS COMPLEX NETWORKS FOR EARLY PREDICTION AND MANAGEMENT OF CHRONIC OBSTRUCTIVE PULMONARY DISEASE

### Goal of the project

To address the problem of COPD (Chronic Obstructive Pulmonary Disease) management in a big population of individuals, using a personalized medicine approach that relies on big data gathering and modeling, according to the complex network paradigm. Our scope is to demonstrate a solution that consists of a mobile and cloud computing integrated system for COPD early detection, monitoring, and management.

### Short description of the project

COPD is defined as the irreversible clinical condition which reduces pulmonary capacity; if diagnosed in an early phase, its evolution can be controlled. Unfortunately, the early detection of COPD is a difficult task. Capitalizing on recent research results which indicate the Internet of Things solutions as useful in monitoring and managing respiratory disorders, we propose a prototype system for early detection and evolution prediction of COPD. As such, we build a sensor network that gathers multiple physiological signals, and a mobile application that extracts the multi-fractal spectra as signal signatures. Then, the mobile system integrates the physiologic signatures with individual clinical data. On the server side, we collect the integrated data from a population of individuals, to build a complex network model of patients. To this end, we employ modularity clustering and network layout tools to build prediction models for both early detection and evolution prediction of COPD. The prediction model is instantiated as a smartphone application and tested to assess its predictive capacity.

### Project implemented by

The research group lead by Mihai Udrescu and affiliated to Advanced Computing Systems and Architectures Lab, Politehnica University of Timișoara, and the Pulmonology Research Group from "Victor Babeș" University of Medicine and Pharmacy lead by Ștefan Mihăicuță.

### Implementation period

3.01.2017 – 30.06.2018

### Main activities

Designing and implementing the mobile software that records anthropometric and clinical data, building a prototype sensor network for collecting physiological signals, implementing the software for multifractal analysis of gathered physiological signals, finding correlations between parameters and data using a complex network model, implementing a software COPD-stage predictor based on the physiological signals.

### Results

1. Methodology for processing medical data based on complex network analysis, which allows for identification of clinically-relevant patient phenotypes. The proposed methodology is published in: Mihaicuta, S., Udrescu, M., Topirceanu, A., & Udrescu, L. (2017). Network science meets respiratory medicine for OSAS phenotyping and severity prediction. *PeerJ*, 5, e3289.
2. Experimental hardware/software platform for gathering and integrating anthropometric, clinical data with physiological signals from COPD patients.



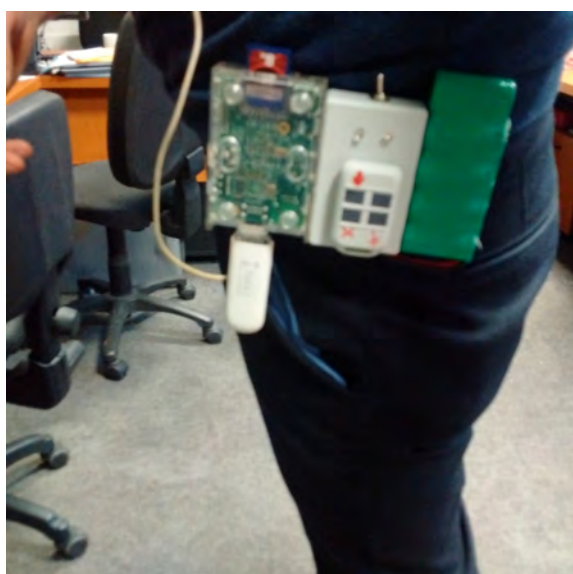

## Applicability and transferability of the results

Active diagnosis and monitoring systems using a wearable sensor network with application in monitoring respiratory disorders.

## Financed through/by

CNCS/CCCDI-UEFISCDI, project number PN-III-P2-2.1-PED-2016-1145, within PNCDI III, contract no. 31PED/2017

## Research centre

Research Center in Computing and Information Technology (CCCTI)

## Research team

Mihai Udrescu,  
Andrei Lihu,  
Alexandru Topirceanu,  
Alexandru Iovanovici,  
Constantina-Elena Gavrilu,  
Stefan Mihaicuta,  
Daniela Reisz,  
Rodica Dan,  
Carmen Ardelean.

## Contact information (Ex)

Assoc. Prof. Mihai UDRESCU, PhD  
Department of Computer and Information Technology  
Address: Bd. Vasile Pârvan, No. 2, 300223, Timisoara  
Phone: (+40) 256 403 278  
E-mail: mihai.udrescu-milosav@upt.ro



## EXPERIMENTAL ASSESSMENT OF A SELF-ADAPTIVE INTELLIGENT TRANSPORTATION SYSTEM

### Goal of the project

At present, all attempts to optimize traffic flow completely ignore the fact that traffic has a predominant social footprint and would therefore potentially benefit from using specific tools to better understand its dynamics and predict its patterns (and thus introduce intelligence). We therefore aim towards designing a distributed, hierarchical, self-adaptive decision-making that would respond quickly to traffic changes based on optimization carried over communities and superior estimation of its patterns.

### Short description of the project

Our systems will: provide local optimizations, allow traffic lights to be networked, and provide global optimizations of traffic flow using decentralized, distributed control.

### Project implemented by

Politehnica University of Timisoara

### Implementation period

Oct. 2017 – Dec. 2018

### Main activities

- Collecting data for urban traffic flow by using semi-permanent sensors
- Modelling existing transport infrastructure with respect to measured traffic values
- Software implementation of algorithms described in Cristian Cosariu's PhD thesis
- Porting the bio-inspired algorithm corresponding to a single node to an embedded platform for implementation on a traffic controller
- Comparative simulation with a before-after analysis of the main quality indicators of the traffic
- High-level description for the architecture and communication framework for adjacent intersections
- Validation by simulation with special tools for the described protocol
- Extensive testing of the embedded platform under realistic operating conditions to achieve 1 year availability
- Participation to at least 2 international conferences

### Results

- Development and online publication of the project's website
- Procurement of hardware and software required for the implementation of the project
- Technical documents with actual traffic values for road segments
- Architectural diagrams and specifications of proposed protocol with validation through simulation
- Source code and standard description of proposed methodology, available online on the project's website

#### Conference papers:

1. Gabriel Baban, Alexandru Iovanovici, Cristian Cosariu, Lucian Prodan.. Determination of the Critical Congestion Point in Urban Traffic Networks: A Case Study. 2017 IEEE 14th International Scientific Conference on Informatics, Poprad, Slovak Republic, November 14 - 16, 2017, doi 10.1109/informatics.2017.8327215.
2. Gabriel Baban, Alexandru Iovanovici, Cristian Cosariu, Lucian Prodan.. High Betweenness Nodes and Crowded Intersections: An Experimental Assessment by Means of Simulation. IEEE 12th International Symposium on Applied Computational Intelligence and Informatics (SACI 2018), May 17-19, 2018, Timisoara, Romania.

## Applicability and transferability of the results

Our algorithm quickly reacts to traffic dynamics based on local heuristics. Real traffic situations simulated using the Vissim software showed a decrease in waiting times and queue lengths at local intersection level. The algorithm can be mapped efficiently onto embedded devices, current TRL-3 standing.

Our SIGS methodology recreates the road network by changing lane directions by using genetic algorithms and also has a current TRL-3 standing.

Intersections will exchange local traffic values and allow genetic algorithms to provide optimizations, which brings this at TRL-2. This will provide distributed, self-adaptive optimization of traffic.

## Financed through/by

UEFISCDI PN-III-P2-2.1-PED-2016-1518, nr. 221PED/2017

## Research centre

- Politehnica university of Timisoara, Faculty of Automation and Computing
- Research Center in Computer and Information Technology (CCCTI)
- Advanced Computing Systems and Architectures Laboratory

## Research team

Lucian Prodan,  
Alexandru Iovanovici,  
Cristian Cosariu,  
Mihai Udrescu,  
Alexandru Topirceanu,  
Iosif Szeidert,  
Flavius Opritoiu,  
Gabriel Baban,  
Dacian Avramoni

## Contact information (Ex)

Assoc.Prof. Lucian PRODAN, PhD  
Faculty of Automation and Computing  
Department of Computer and Software Engineering  
2 Vasile Parvan, RO-300223 Timisoara  
Phone: (+40) 256 403 278  
Mobile:  
E-mail: lucian.prodan@upt.ro  
Web: wikitrafic.cs.upt.ro

## PARKING ASSISTANCE SYSTEM FOR TPAK

### Goal of the project

The objective of the "Parking Assistance System for TPAK" project was to extend the services offered to the clients of Piconet company, which is the national leader of city surface parking management systems. The aim was to develop a robust method for monitoring the parking occupancy based on processing of images captured by surveillance cameras. This method has to adapt to harsh weather conditions and to changing in illumination due to some natural causes as clouds or artificial as night lighting.

### Short description of the project

The project work result was a working prototype implementing the proposed method able to process the information provided by parking surveillance cameras. The method combines image processing algorithms with statistical information collected by the company, and with learned data.

### Project implemented by

Universitatea Politehnica din Timisoara

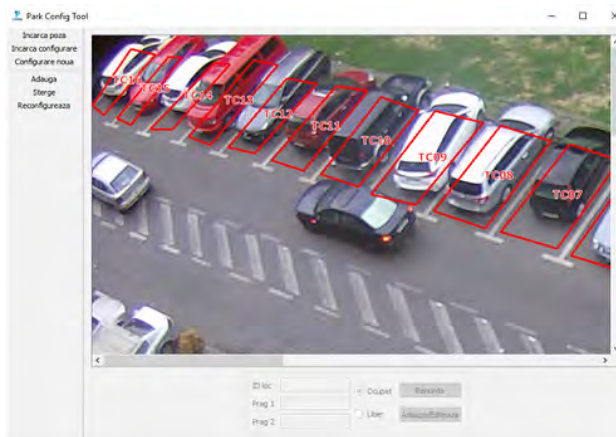

### Implementation period

25/07/2017 – 31/12/2017

### Main activities

Activity 1. Developing a robust method to monitor the state of parking places in public car parks by processing information from surveillance cameras.

Activity 2. Implementing a prototype of the monitoring system to validate the method in a real use case on Timisoara Central parking.



Activity 3. Developing a method for estimating the time of parking space occupancy.

Activity 4. Extending the prototype of the monitoring system to allow validation of it.

Activity 5. Developing and documenting a methodology for installing and configuring the prototype of the monitoring system.

### Results

- A method to monitor the status of parking occupancy for a surface parking lot.
- A prototype to validate the method implemented in C++ using the OpenCV open source library.
- A method for estimating the time of parking space occupancy.
- An extension of the first prototype in order to validate this method.
- Research report describing the proposed approach and a Web page to document the project and the obtained results.

## Applicability and transferability of the results

The results will be used to extend the services offered by Piconet company for its clients represented by the drivers searching for a public parking space. It will be integrated in the company monitoring system and will be offered to new clients interested in extended services. The company also planned to implement a mobile application capable to offer online information on free parking places based on this monitoring system.

## Financed through/by

Budget: Unitatea Executiva pentru Finantarea Invatamantului Superior, a Cercetarii, Dezvoltarii si Inovarii (UEFISCDI) - Directia de Finantare a Dezvoltarii si Inovarii  
Co-financing: S.C. Piconet SRL

## Research centre

Research Center in Computers and Information Technology (CCCTI), UPT

## Research team

Director: Assoc.Prof. Dan Pescaru, PhD  
Researcher: Lect. Codruta Istin, PhD  
As. Researcher: Drd. Marius Baba

## Contact information (Ex)

Assoc.Prof. Dan PESCARU, PhD  
Faculty of Automation and Computers/  
Department of Computer and Information Technology:  
Bd. V. Parvan no 2, 300223 Timisoara, Romania  
Phone: (+40) 256 403 259  
E-mail: dan.pescaru@upt.ro  
Web: www.cs.upt.ro/~dan/

## DEVELOPMENT OF URBAN GREEN SPACE MONITORING TECHNIQUE WITH REMOTE SENSING AND ITS APPLICATION

### Goal of the project

City is the important area of earth's surface material, energy, and information exchanging; also it is the center in national, regional political, economic, scientific and cultural aspects. Remote sensing imagery enables rapid and efficient quantification urban eco-environment and it gives a new insight for urban environmental research. A wide range of urban remote sensing applications is available.

With the availability of super high resolution remotely sensed imageries and multi-source remote sensing data, there is a great need to transform remote sensing data into useful information that we need for urban studies. High resolution remote sensing data make a clear potential to help humans to make a better understanding of their living places, to measure the biophysical parameters of urban vegetation, to model the environmental process in urban areas, to map the urban features quickly, to update the urban land covers, etc.

### Short description of the project

In the scientific literature, there are studies on the urban green space monitoring based on modeling the proximity of buildings to green space with remote sensing using multi-source satellite images. The study achievement would provide reference for the measurements of green space, serve the urban eco-environment quality monitoring. At the same time, it was of great theory and practical significance to improve utility efficiency of satellite data and eco-environment monitoring precision. The project would build up stable demonstration for scientific and technology cooperation and exchanging between Romania and China, and make cooperation deeper and more durative.

### Project implemented by

- Chinese Academy of Science, Institute of Remote Sensing and Digital Earth, Prof. Meng Quinyan
- Politehnica University of Timisoara, Faculty of Civil Engineering, Assoc. Prof Sorin Herban

### Implementation period

October 2016 – December 2017

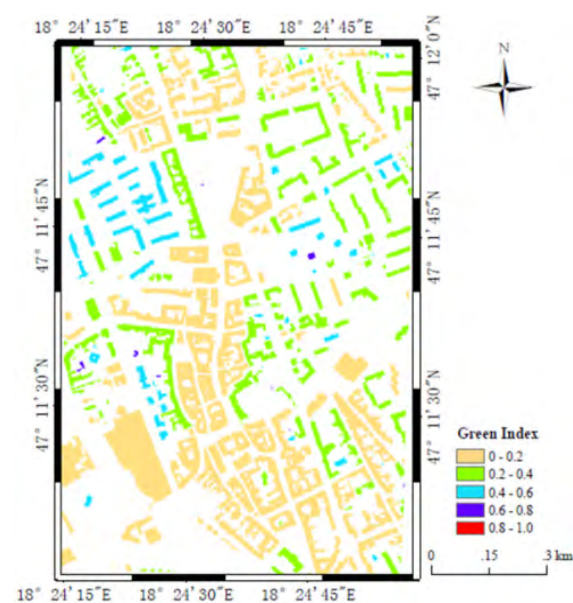
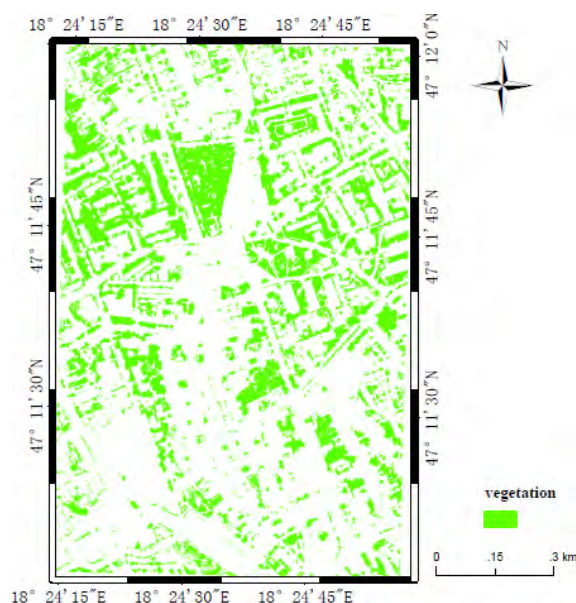

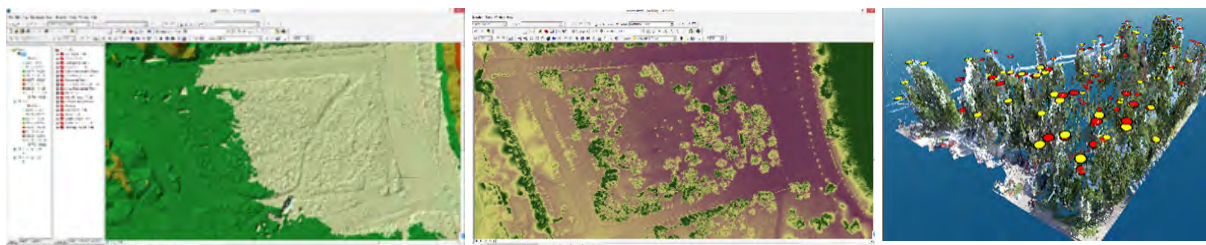

## Main activities

- Techniques for multi-source remotely sensed data fusion;
- Development of new classification algorithms for urban mapping using high resolution remotely sensed data;
- 3D modeling of urban features based on high resolution remotely sensed data;
- Development of an urban green space evaluation model;
- Studying the urban green space parameters quantitative retrieval technology;
- Generation of the Normalized Height Model (NHM);
- Collection of LiDAR data on urban areas;
- Collection of DEM (Digital Elevation Model) on urban areas;
- Generation of DSM (Digital Surface Model) from LiDAR data;
- Generation of the Normalized Height Model by subtracting the DEM from the DSM;
- Image segmentation algorithms;
- Design of a robust segmentation algorithm for urban feature segmentation;
- Segmentation accuracy assessment;
- Extraction of Urban Buildings;
- Building mapping;
- Generation of Building Height model;
- 3D modeling of urban trees using LiDAR;
- Urban green mapping;
- Tree detection and the 3D modeling of the urban trees;
- Urban green mapping using Multi-spectral images;
- Machine learning techniques for classification of urban green;
- Shadow detection and removal;
- Accuracy assessment.

## Results

Develop an evaluating system for measuring the quality of the urban environment using remote sensing technology.

Probe the relations between green space and other environmental elements based on the space-time multi-scale urban green space model.

Demonstrate the urban green space monitoring technology among different cities.

## Applicability and transferability of the results

The project is expected to exchange the GIS & RS technologies in evaluating urban eco-environment of both countries to validate that the established urban eco-environmental model can be suitable for both countries.

The expected results will provide the local governments with the change direction of local urban ecological environment, and be benefit for the environmental management or policies. It will help the sustainable urban development works.

## Financed through/by

Unitatea Executivă pentru Finanțarea Învățământului Superior, a Cercetării, Dezvoltării și Inovării UEFISCDI

## Research Centre

Infrastructures for Constructions and Transportation (ICT)

## Research team

Assoc. prof.dr.ing. Sorin HERBAN  
Prof.dr.ing. Carmen GRECEA  
Prof.dr.ing. Viorel UNGUREANU  
Asist. prof.dr.ing. Rares HABAC COTOARA ZAMFIR  
Asist. prof.dr.ing. Beatrice VILCEANU

## Contact information

Prof. Sorin HERBAN, PhD  
Faculty of Civil Engineering / Department, CCTFC  
Address: Traian Lalescu 2A, 300223 Timișoara  
Phone: (+40) 256 40 3978  
Mobile: (+40) 722 22 3952  
E-mail: sorin.herban@upt.ro



## NOVEL NANOMATERIALS BASED STRATEGIES FOR INNOVATIVE SENSING SYSTEMS APPLIED IN SAFETY AND QUALITY CONTROL OF NATURAL JUICE

### Goal of the project

The main goal of the project is to contribute greatly exploratory research in developing new electrode materials with advanced properties linked to the original exploitation of certain electroanalytical techniques envisaging smart strategies for food quality control and safety.

### Short description of the project

This research proposal envisage an important contribution to food quality control and safety through elaboration of new strategies for qualitative and quantitative evaluation of the potentially harmful compounds (residues of pesticides and preservatives) from natural juices, by involving well-controlled nanomaterials in the development of innovative detection systems with improved electroanalytical performances. Detection systems will be based on new glassy carbon sensors modified with carbon nanostructures and metallic nanoparticles that will allow the elaboration of selective/simultaneous detection protocols for preservatives and pesticides, potentially present in juices. Sensor surface modification with membrane will permit selective access of target analytes only to carbon nanostructures, allowing a specific concentration on the electrode surface.

Expected performance of detection strategies proposed by project open the perspective of practical applications in the direction of their use by regulatory bodies for food quality control or even by natural juices producers, either before processing of the potentially contaminated fruits with pesticide residues, either on the production flow or final product quality evaluation/monitoring.

### Project implemented by

Faculty of Industrial Chemistry and Environmental Engineering

### Implementation period

01.10.2015 - 30.09.2017

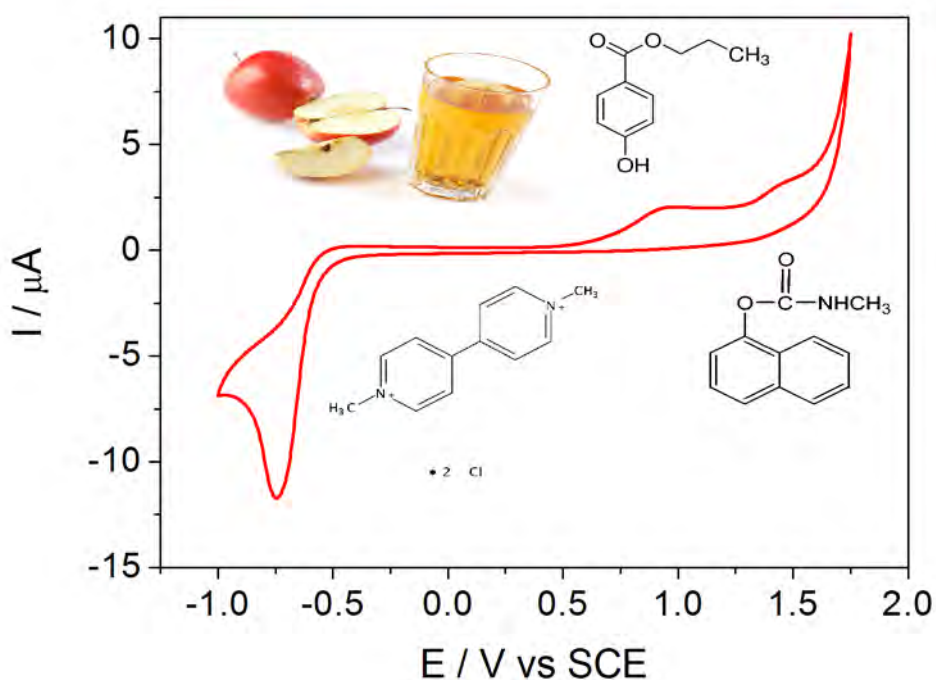

## Main activities

- i. Obtaining new sensors based on nanostructured carbon by modifying classic glassy carbon (GC) electrode with CNT/CNF/graphene/fullerene characterized by structural, morphological and electrochemical specific properties suitable for electrochemical detection applications.
- ii. Sensors functionalization with metallic nanoparticles (Cu/Ag/Au/Pt) by advanced electrochemical (multiple-pulsed amperometry – MPA, chronoamperometry – CA and cyclic voltammetry - CV) with morpho-structural and electrochemical properties characteristic to the electrochemical detection applications.
- iii. Elaboration of procedure/detection schemes for target analytes from preservatives and pesticide residues categories based on obtained new sensors and their optimization.
- iv. Development of detection techniques with intermediate preconcentration step on electrode surface for harmful compounds at trace levels from test sample, exploiting adsorbent properties of nanostructures carbon.
- v. Elaboration of simultaneous and/or selective detection procedures/schemes of selected target analytes, by sensors modification with selective membranes.
- vi. Procedures checking through detection strategies elaboration for specific applications in juices quality control and safety.

## Results

- New sensors modified with nanostructured carbon (carbon nanotubes (CNT), carbon nanofibers (CNF), fullerenes and graphene) and/or metallic nanoparticles (Cu / Ag / Au / Pt) for natural juices safety and quality control applications.
- Protocols for selective/ simultaneously detection of preservatives and pesticides potentially present in natural juices.

## Applicability and transferability of the results

New sensors modified with nanostructured carbon (carbon nanotubes (CNT), carbon nanofibers (CNF), fullerenes and graphene) and/or metallic nanoparticles (Cu / Ag / Au / Pt) for natural juices safety and quality control applications.

Protocols for selective/ simultaneously detection of preservatives and pesticides potentially present in natural juices.

## Financed through/by

Executive Unit for Financing Higher Education, Research, Development and Innovation - UEFISCDI

## Research centre

Research Institute for Renewable Energy – ICER TM  
Research Centre in Environmental Science&Engineering

## Research team

Assist. Prof. Aniela POP, PhD  
Prof. Florica MANEA, PhD  
Postdoctoral researcher Anamaria BACIU, PhD  
Postdoctoral researcher Agnes JAKAB, PhD  
PhD. student Adriana (BĂLĂȘOIU) FLUERAȘ  
PhD. student Ianina BÎRSAN

## Contact information

Assist. Prof. Aniela POP, PhD  
Department of Applied Chemistry and Inorganic Compounds and Environmental Engineering  
Address: Bd. Vasile Pârvan, No. 6, RO 300223, Timisoara  
Phone: (+40) 256 403 069  
E-mail: [aniela.pop@upt.ro](mailto:aniela.pop@upt.ro)  
Web: <https://sites.google.com/site/sensojuice>



## DEVELOPMENT OF NANOSTRUCTURED MAGNETIC COMPOSITES USED AS NANO-ADSORBENTS AND NANO-CATALYSTS WITH HIGH PERFORMANCE IN ENVIRONMENTAL APPLICATIONS

### Goal of the project:

Developing new efficient synthesis variants of oxide nanoparticles in order to obtain nanomaterials, magnetic nanostructures based on iron oxides ( $\gamma\text{-Fe}_2\text{O}_3$ ,  $\text{Fe}_3\text{O}_4$ , ferrites spinels  $\text{MFe}_2\text{O}_4$ ) with tailored properties for their use as nano-adsorbents and nano-catalysts for remediation of water.

### Short description of the project:

Water pollution by heavy metals and organics has become a serious problem because of their extremely hazardous effects on humans and the ecological systems.

The present project is focused on the developing of nanostructured magnetic materials based on iron oxides (magnetite, maghemite, spinel ferrites) with special properties (magnetic properties, specific surface area and morphology) that can be used as high performance nano-adsorbents and nano-catalyst for the removal of inorganic (metals ions: Cd(II), Pb(II), Cr(VI), Cu(II), Co(II), Zn(II)) and organic (dyes and phenols) pollutants from wastewaters. In order to achieve this we will develop new, original versions of the two unconventional synthesis methods of nanopowders and nanocomposites: solvothermal method and thermal decomposition of precursors. In order to develop high performance nanostructured magnetic oxides (iron oxides and ferrites) with high specific surface area, porosity and adequate magnetic properties composites like magnetic oxides/carbon will be synthesized by these methods, using different common carbon precursors in order to obtain low cost final materials. Also, the functionalization of surface will be performed with different organic modifiers in order to make the nanoparticles specific for certain applications.

Finally, the obtained iron oxides based magnetic nanostructures materials (oxides, ferrites and composites) will be tested as nanoadsorbants and catalyst for the removal of water pollutants.

### Project implemented by

University Politehnica Timisoara

### Implementation period:

01.10.2015-30.09.2017

### Main activities:

I. Synthesis of magnetic oxide nanopowders ( $\text{Fe}_x\text{O}_y$ ,  $\text{MFe}_2\text{O}_4$ ) by new, original variants of solvothermal method and of thermal decomposition of the precursors and powders characterization.

A.I.1 Study of the influence of organic solvents' nature on the structure and morphology of the oxide particles obtained by solvothermal

method. Determination of the most appropriate solvent for the synthesis of a series of solvents which have not been reported in the literature.

A.I.2 Study of the influence of polyols nature and polyol: metal nitrates ratio and of the presence of surfactants on the structure, morphology, magnetic properties of nanopowders synthesized by the method of decomposition of precursors.

A.I.3 Characterization of materials obtained by thermal analysis, FT-IR spectroscopy, X-ray diffractometry, specific surface area and porosity measurements, Mosbauer spectroscopy, X-ray diffractometry, SEM, TEM electron microscopy, magnetic measurements.

A.I.4 Writing scientific report and disseminate the results through participation in an international conference. Making the project web page

II. Synthesis of the nanocomposites type  $\text{Fe}_x\text{O}_y / \text{C}$  and  $\text{MFe}_2\text{O}_4 / \text{C}$  by original synthesis methods and their characterization

A.II.1 Study of the influence of process parameters: temperature and autoclaving time on the structure, morphology and properties of synthesized nanocomposites

A.II.2 Study of the influence of organic solvents' nature on the structure and morphology of the oxide particles obtained by solvothermal method. Determination of the most appropriate solvent for the synthesis of a series of solvents which have not been reported in the literature

A.II.3 Study of the influence of initial oxide precursor: carbon precursor ratio on the carbon content of the composite.

A.II.4 Study of the influence of carbon precursor nature on the carbon content of composites with carbon and their morphology

A.II.5. The obtaining of composites by thermal decomposition of precursor method: influence of decomposition atmosphere, calcination temperature and time and of the presence of other carbon precursors in addition beside the polyol used as a reductant.

A.II.6 Characterization of the obtained nanocomposites by thermal analysis, FT-IR, X-ray diffractometry, the specific surface area and porosity measurements, Mössbauer spectroscopy, X-ray diffractometry, electron microscopy, SEM, TEM, magnetic measurements.

A.II.6 Writing scientific report and disseminate the results through participation in an international conference and publication of an ISI

article.

III. Testing of magnetic powders synthesized as adsorbent materials and catalysts for removal of inorganic and organic pollutants in water

A.III.1 Testing of oxide nanopowders  $\text{Fe}_3\text{O}_4$ ,  $\text{Fe}_2\text{O}_3$ ,  $\text{MFe}_2\text{O}_4$  compared to the corresponding nanocomposite  $\text{Fe}_3\text{O}_4/\text{C}$ ,  $\text{Fe}_2\text{O}_3/\text{C}$ ,  $\text{MFe}_2\text{O}_4/\text{C}$  as a metal ion adsorbents: Cd (II), Cr (VI), Pb (II), Cu (II), Ni (II), Co (II)

A.III.2 Testing of oxide nanopowders  $\text{Fe}_3\text{O}_4$ ,  $\text{Fe}_2\text{O}_3$ ,  $\text{MFe}_2\text{O}_4$  compared to the corresponding nanocomposites  $\text{Fe}_3\text{O}_4/\text{C}$ ,  $\text{Fe}_2\text{O}_3/\text{C}$ ,  $\text{MFe}_2\text{O}_4/\text{C}$  as adsorbents for organic contaminants: colorants and phenolic compounds.

A.III.3 Testing of functionalized oxide powders as adsorbents for inorganic and organic pollutants studied. Study on the influence of nature of surface functional groups on pollutant removal efficiency

A.III.4 Testing of  $\text{Fe}_x\text{O}_y$  and  $\text{MFe}_2\text{O}_4$  magnetic powders as catalysts for catalytic oxidative degradation of organic pollutants: dyes and phenolic compounds

A.III.5 Study the possibility of regeneration of the adsorbent material by controlled desorption of adsorbed species in different solvents or by changing the pH.

A.III.6 Study of adsorbent material reuse on its performance (maximum capacity of adsorption of pollutant removal efficiency). Proposing a technological schemes for use in remediation of water nanopowders

A.III.7 Preparing final scientific report. Dissemination of results: patent proposal preparation and submission and publication of 2 ISI papers..

## Results:

Published papers:

1. Stoia M., Istrate R., Pacurariu C., Investigation of magnetite nanoparticles stability in air by thermal analysis and FTIR spectroscopy, *Journal of Thermal Analysis and Calorimetry* (2016) 125, 1185–1198
2. Stoia M., Pacurariu C., Istrate R., Barvinschi P, Locovei C., Thermoanalytical techniques: Excellent tools for the characterization of ferrite/SiO<sub>2</sub> nanocomposites and their precursors, *Journal of Thermal Analysis and Calorimetry* (2016) 125, 1249–1263,
3. Stoia M., Pacurariu C., Muntean E.C., Thermal stability of the solvothermal-synthesized MnFe<sub>2</sub>O<sub>4</sub> nanopowder, *Journal of Thermal Analysis and Calorimetry*,

Conferences

1. Cornelia Muntean: The XXXVIII National Congress on Calorimetry, Thermal Analysis and Applied Thermodynamics (AICAT-GICAT 2016) Ischia (Naples), Italy, September 25-28, 2016  
Cornelia Muntean, Marcela Stoia, Geza Bandur: Thermal evolution OF MnFe<sub>2</sub>O<sub>4</sub> precursors obtained by co-precipitation in organic medium

2. Eliza Muntean: 25-th Symposium on Thermal Analysis and Calorimetry - Eugen Segal, Bucuresti, Romania, Februarie, 2016

Stoia M, Muntean Eliza, Pacurariu C, Study on thermal evolution of MnFe<sub>2</sub>O<sub>4</sub>/C composites synthesized by solvothermal method

3. Muntean Eliza: "New trends and strategies in the chemistry of advanced materials with relevance in biological systems, technique and environmental protection" 9th Edition, June 09-10, 2016

Muntean E., Stoia M., Pacurariu C. Solvothermal synthesis of manganese ferrite nanopowders using different surfactants

## Applicability and transferability of the results:

This project will develop innovative and original solutions, both in terms of getting nanomaterials used as nano-adsorbents or nanocatalysts in wastewater treatment processes and in terms of regeneration of adsorbents / catalysts and their reintroduction in the process of treatment the waste water, so as to minimize the impact on the environment.

The project aims to find effective solutions as easy to achieve as practical and cheap for treatment of effluents loaded with ions of heavy metals and organic pollutants (dyes and phenols) using as adsorbents the magnetic oxide nanopowders to be obtained.

## Financed through/by

Executive Agency for Higher Education Research, Development and Innovation Funding (UEFISCDI)

## Research Center

Research Institute for Renewable Energy , University Politehnica Timisoara

## Research team

Project leader: Lecturer eng. Stoia Marcela Elena, PhD

Senior researcher: Lecturer eng. Muntean Cornelia Veronica, PhD

Postdoctoral researcher: Lecturer. eng. Lupa Lavinia, PhD

Postdoctoral researcher : Assist. eng. Moaca Alina, PhD

PhD student: eng. Muntean Eliza

PhD student: eng. Gabor Andreea

## Contact information

Lecturer. Marcela STOIA, PhD

Faculty of Industrial Chemistry and Environmental Engineering/  
Department CAICAM

Address: Bvd. Vasile Parvan., No.6, 300223, Timisoara

Phone: (+40) 256 404158

Mobile:

E-mail: marcela.stoia@upt.ro

## SOLAR LIGHT- ACTIVATED NANO-TiO<sub>2</sub> DOPED WITH SILVER-COVERED ACTIVATED CARBON AND ZEOLITE BASED PHOTOCATALYTICALLY-ASSISTED FILTERING SYSTEM FOR WATER TREATMENT (WATICAZ)

### Goal of the project:

The WATICAZ project scope is to develop an innovative water treatment unit characterized by enhanced performance consisted of the photocatalysis-assisted filtering system (PFS) as experimental demonstrator at laboratory scale for the treatment of real drinking water source. This system should exhibit the bifunctional adsorptive and photocatalytic characteristics that can be exploited either as filtering system with the possibility of solar photocatalytic regeneration (SPR) or as advanced oxidation unit to remove/degrade a large range of contaminants from water.

### Short description of the project

The photocatalytic-assisted filtering unit using (doped)TiO<sub>2</sub>-covered activated carbon/zeolite operated under UV/solar irradiation is developed.

### Project implemented by

Partnership between Politehnica University of Timisoara and National Institute for Research and Development for Electrochemistry and Condensed Matter

### Implementation period

03.01.2017-29.06.2018

### Main activities

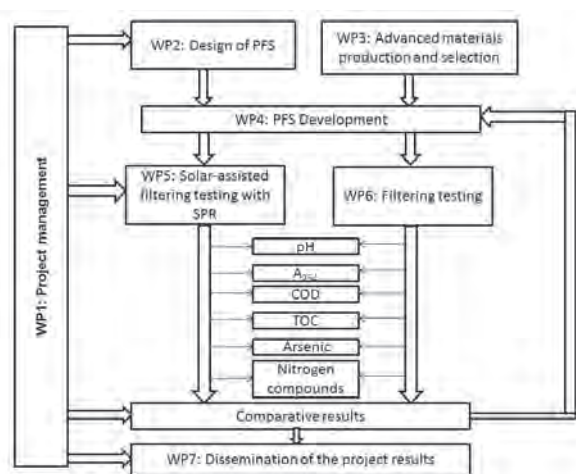

Project flow chart with work packages (WPs)

The main work packages and tasks are:

- Project management;
- Design of photocatalysis-assisted filtering system (PFS);
- Filtering materials production and selection (*Synthesis of the filtering materials characterized by the photocatalysis activity; Characterization of filtering materials by XRD, SEM, AFM, BET, DRUV-VIS*);
- (Solar-assisted) filtering testing (with solar photocatalytic regeneration - SPR) (*Filtering column filling; Functional and operational testing of (solar irradiation photocatalysis-assisted) filtering system; Filtering material regeneration under solar irradiation; Morpho-structural characterization of materials after its usage; Validation by testing for the treatment of the real drinking water source*);
- Dissemination of the results.

### Results

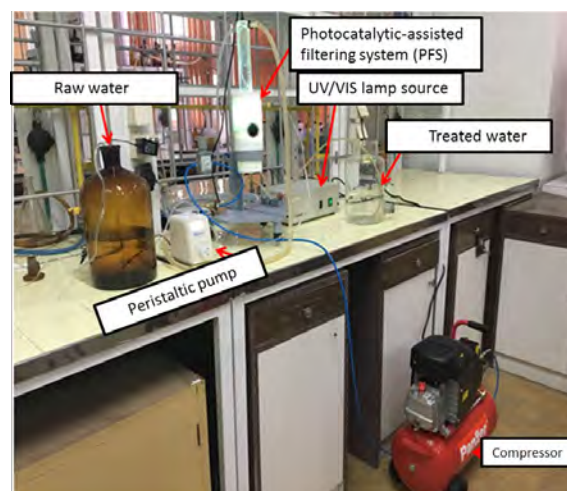

Photocatalysis-assisted filtering unit

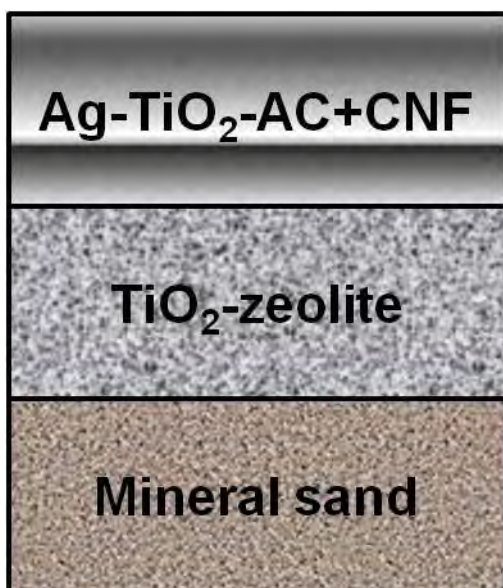

Layers of materials in filtering column

## Applicability and transferability of the results

Drinking water and wastewater treatment plants

## Financed through/by

Executive Agency for Higher Education, Research, Development and Innovation Funding (UEFISCDI)

## Research Center

Research Center of Environmental Science and Engineering

## Research team

Prof.dr.eng. Florica Manea  
Prof.dr.eng. Rodica Pode  
Prof.dr.eng. Vasile Pode  
Lecturer dr.eng. Andra Tamas  
Prof.assist.dr.eng. Aniela Pop  
Tehn. Eng. Lacrima-Crysty Ighian  
Master student eng. Sorina Negrea

## Contact information

Prof. Florica MANEA, PhD  
V. Parvan Sq. no. 6, 300223  
Phone: (+40) 256 403070  
Mobile: +40274506095  
E-mail: florica.manea@upt.ro  
Web: <http://www.chim.upt.ro/ro/cercetare/proiecte-de-cercetare/248-pn-iii-p2-2-1-ped-2016-0265>

## ADVANCED MATERIALS BASED ON COMBUSTION-SYNTHESIZED MAGNETIC IRON OXIDES NANOPARTICLES AND THEIR CYTOTOXICITY DESIGNED FOR CANCER TREATMENT

### Goal of the project:

- Obtaining of magnetic iron oxides nanoparticles using the combustion synthesis method and monitoring the influence of several working parameters: fuel type (EDTA, citric acid, glucose), oxidant/fuel molar ratio (fuel-rich compositions), ignition procedure (heating mantle, microwave field), working atmosphere (in air/no air), carbon and organic residues presence.
- Preparation of colloidal suspensions.
- The assessment of the toxicological profile/biological activity of the iron oxide colloidal suspensions on normal/tumour liver and kidney cell lines.

### Short description of the project

The project presents the preparation of iron oxides with via combustion synthesis and testing their selective cytotoxicity.

### Project implemented by

Department of Applied Chemistry and Engineering of Inorganic Compounds and Environment,  
Faculty of Industrial Chemistry and Environmental Engineering,  
Politehnica University Timisoara

### Implementation period

July 2017–December 2019

### Main activities

Combustion synthesis of magnetic iron oxides nanoparticles. The influence of several parameters on the powders characteristics were pursued:

- nature of the fuel: glucose, citric acid, EDTA, TWEEN 80, hexamethylenetetramine
- reaction conditions: presence and absence of air
- carbon and organic residues presence and chemical oxidation removal using  $H_2O_2$

Characterization of magnetic iron oxides nanoparticles:

- combustion reactions evolution was assessed by TG-DSC thermal investigations
- the phase composition of the synthesized compounds was investigated by XRD
- specific surface area (BET)
- FTIR spectroscopy

The obtained results were centralized and interpreted for recipes optimization.

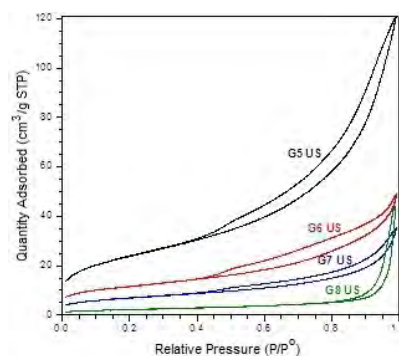
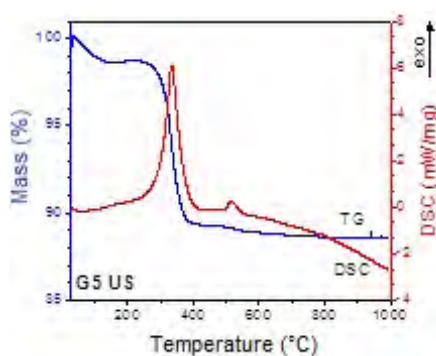
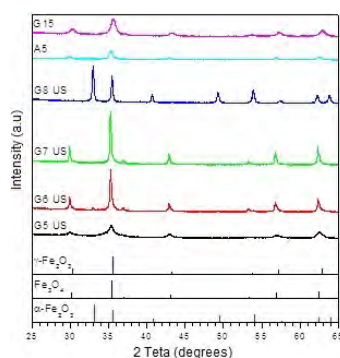

## Results:

Synthesis protocols and recipes for 31 samples prepared by combustion synthesis. It was established the influence of different fuels (glucose, citric acid, EDTA, TWEEN 80, hexamethylenetetramine) and of the reaction conditions on the synthesis of iron oxides with magnetic properties.

## Applicability and transferability of the results

These researches open an entirely new perspective on the potential use of combustion-synthesized iron oxide nanoparticles in cancer therapy by selective cytotoxicity.

The results will be subjected to a patent application.

## Financed through/by

Ministry of Research and Innovation, CNCS - UEFISCDI,  
project number  
PN-III-P4-ID-PCE-2016-0765, within PNCDI III

## Research Center

Research Centre for Inorganic Materials and Alternative Energies

## Research team

1. Cornelia Pacurariu - project leader
2. Cristina Dehelean - experienced researcher
3. Robert Ianos - experienced researcher
4. Radu Lazau - experienced researcher
5. Dorina Coricovac - postdoc researcher
6. Alina Moaca - postdoc researcher
7. Roxana Babuta (Racoviceanu) - postdoc researcher
8. Eliza Muntean - PhD student
9. Aylin Capraru - PhD student

## Contact information

Prof. Cornelia PĂCURARIU, PhD  
Faculty/Department Address: Bd.V. Pîrvan, No.6 Postal Code 300223,  
Timisoara  
Phone: (+40) 256 404 144  
Mobile: +40 722 54 75 18  
E-mail: cornelia.pacurariu@upt.ro  
Web: <http://www.chim.upt.ro/ro/caicam>



## BIOCATALYST- CLICK CHEMISTRY DOWNSTREAMING TANDEM BASED INNOVATIVE KIT FOR OPTICALLY PURE FINE CHEMICALS SYNTHESIS

### Goal of the project:

Development of an innovative kit for efficient and cost-effective sequential continuous flow large-scale (multigram) preparation of optically pure chiral building blocks useful for synthesis of pharmaceutical compounds and agricultural chemicals, based on the tailor-made immobilized lipases mediated kinetic resolution of various racemic substrates and a subsequent click chemistry-type downstreaming of the reaction mixture.

### Short description of the project

A chemo-enzymatic process which integrates several innovative steps in both biocatalytic and down streaming parts was set up. The use of an immobilized biocatalysts-click chemistry tandem allowed to design easily scaled-up continuous flow procedures for industrial manufacturing of the target compounds.

### Project implemented by

- University Politehnica Timișoara - Project leader
- University "Babes-Bolyai" Cluj Napoca - Project Partner 1
- Natural Ingredients R&D S.R.L. - Project Partner 2

### Implementation period

01.07.2014 - 30.09.2017

### Main activities

1. Synthesis of various precursors: (hetero)aryl-ethanols, amines, hydroxy- and amino acids, as well as various propargylic esters as O- and N-acylating agents for enzymatic kinetic resolution (EKR).
2. Development of optimal EKR and click-chemistry type downstreaming procedures.
3. Immobilization of lipases.
4. Development of the continuous flow procedure, on model substrates and newly synthesized substrates.

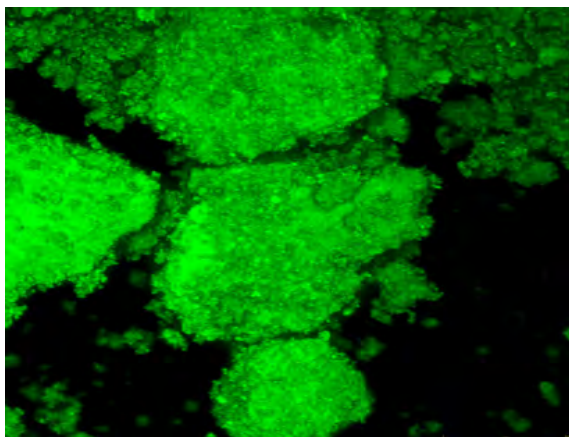
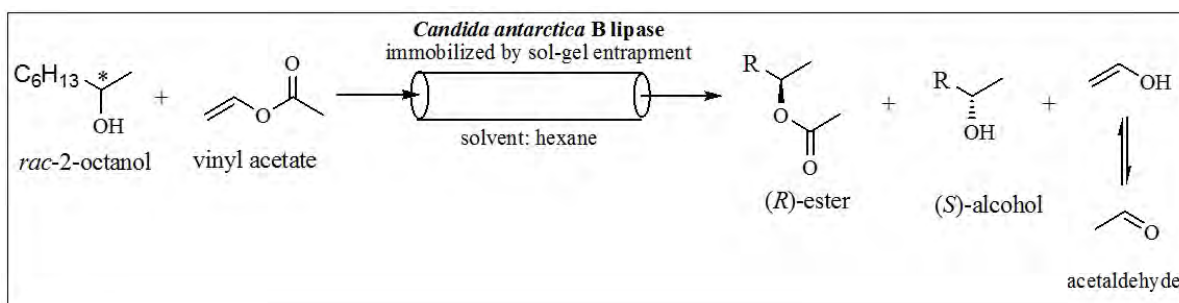

Fluorescence image of the sol-gel immobilized lipase

### Results

Racemic compounds holding a secondary OH group were subjected to lipase mediated kinetic resolution in the presence of an ester having a terminal ethynyl group. Click methodology was used to separate the enzymatic acylation reaction products, also at preparative scale, under the optimal reaction conditions identified on the analytical scale. Heteroaromatic compounds were synthesized with high optical purity (93-99%) and yields between 90-95%. The effectiveness of sol-gel immobilized enzyme preparations in enzymatic kinetic resolution reactions was tested in a continuous system for both aliphatic and aromatic substrates. The reactions were optimized by factorial experimental programs using the Box-Behnken method.

For the enzymatic kinetic resolution of rac-2-chloromandelic acid lipase from *Candida antarctica* A proved to be the most active, immobilized by entrapment in sol-gel matrices based on ternary mixture of silanes combined with adsorption on Celite.

Please visit also: <http://chim.upt.ro/ro/cercetare/proiecte-de-cercetare/145-pn-ii-pt-pcca-2013-4-0734>

Selected publications in the field of the project:

1. A. Todea, P. Borza, A. Cimporescu, C. Paul, F. Peter, *Catalysis Today*, 2017, <https://doi.org/10.1016/j.cattod.2017.02.042>.
2. M. E. Moisă, C. G. Spelmezan, C. Paul, H. J. Bartha-Vári, L. C. Bencze, F. D. Irimie, C. Paizs, F. Péter, M. I. Toşa, *RSC Advances*, 2017, 7, 52977-52987.
3. A. Cimporescu, A. Todea, V. Badea, C. Paul, F. Peter, *Process Biochemistry*, 2016, 51(12), 2076-2083.
4. D. Aparaschivei, A. Todea, I. Păușescu, V. Badea, M. Medeleanu, E. Șișu, M. Puiu, A. Chiriță-Emandi, F. Peter, *Pure and Applied Chemistry*, 2016, 88 (12), 1191-1201.
5. C. Paul, P. Borza, A. Marcu, G. Rusu, M. Birdeanu, S. Marc Zarcu, F. Peter, *Nanomaterials and Nanotechnology*, 2016, 6:0, doi: 10.5772/62194.8.

## Applicability and transferability of the results

The application of tailor-made biocatalysts in industrial processes increases the economic benefits compared to the synthetic solutions. The productivity, stability, enantiomer selectivity and reusability of the enzymes increase by immobilization. The immobilized biocatalysts can be used in continuous bioreactors, under harsher conditions. The results will be scaled-up by the industrial partner, but they are available for all companies interested in fine synthesis of optically active compounds.

## Financed through/by

Romanian Authority for Scientific Research and Innovation (UEFISCDI), Partnership - type project, project number PN-II-PT-PCCA-2013-4-0734 / 01.07.2014

## Research Center

Research Centre in Organic, Macromolecular and Natural Compounds Chemistry and Engineering

## Research team

### Politehnica University Timișoara

Director: Prof. Dr. Eng. Francisc Peter

Members:

Dr. Eng. Cristina Paul

Dr. Eng. Valentin Badea

Dr. Eng. Emese Biro

Dr. Eng. Anamaria Todea

Eng. Adinela Cimporescu, PhD student

Eng. Claudiu Marcu, PhD student

Eng. Paula Borza, PhD student

Eng. Ioana Brăzdău

### University "Babes-Bolyai" Cluj Napoca

Responsible: Prof. Dr. Eng. Monica Ioana Toşa

Members:

Prof. Dr. Eng. Florin Dan Irimie

Prof. Dr. Eng. Csaba Paizs

Dr. Eng. Csaba Bencze

Dr. Eng. Botond Nagy

Eng. Mădălina Moisă, PhD student

Eng. David Bedo, PhD student

### Natural Ingredients R&D S.R.L.

Responsible: Eng. Petru Antin Bârzan

Members:

Dr. Eng. Rosenberg Ladislau

Eng. Gabriela Bârzan

Ec. Carmen Aurelia Bârzan

David Lucian Comănicu

## Contact information (Ex)

Prof. Francisc PETER, PhD

Faculty of Industrial Chemistry and Environmental Engineering

Department of Applied Chemistry and Engineering of Natural and Organic Compounds

C. Telbisz str. 6, 300001 Timisoara, Romania

Phone: (+40) 256 404216

Mobile: (+40) 745637530

E-mail: francisc.peter@upt.ro



## RECYCLABLE MULTILAYER MAGNETIC BIOCATALYST FOR SYNTHESIS OF NATURAL ESTERS

### Goal of the project:

The main goal of the project is to develop a demonstration model for a new biocatalyst containing a designed magnetic core and hybrid layers (organic and silica) that allow the immobilization of enzymes. The validation of the model will be accomplished through the effectiveness of the product in a specific reaction, to demonstrate that such a biocatalyst is stable, reproducible, recyclable and able to synthesize esters that are accepted as naturals according to the EC regulations (Regulation no 1334/2008 of the European Parliament and subsequent amendments).

### Short description of the project

The key objective is a comprehensive evaluation of the magnetic manipulation efficiency of enzyme functionalized magnetic nanocomposites obtained by applying cost-effective preparation procedures and manifold advanced characterization and testing techniques. The chemical composition, structure, size distribution, magneto- responsiveness and size, as well as the enzyme loading capability will be designed to fulfill the requirements for efficient biocatalysis and easy recovery of the enzyme even from viscous media, avoiding the contamination of the product and allowing its recognition as "food-grade".

An innovative multilayer technology will accomplish the demonstrative model. The immobilization of lipase on controlled-size magnetic core nanoparticles will be combined with stabilization of the hybrid composite through a sol-gel silica shell. The size and magnetic properties of the core particles will be adjusted to allow the optimal catalytic efficiency.

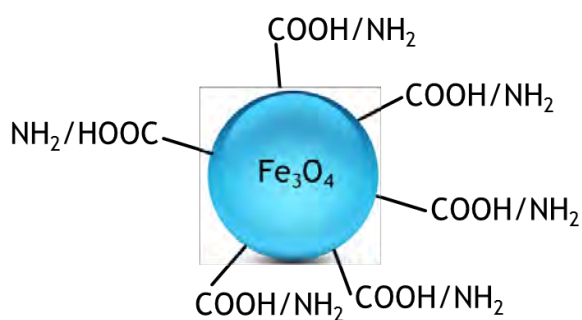

### Project implemented by

- University Politehnica Timișoara-Project leader
- National Institute for Research and Development of Isotopic and Molecular Technologies INCOTIM Cluj-Napoca - Project partner

### Implementation period

30.01.2017- 29.06.2018

### Main activities

The objective of the project is to develop a demonstration model for a new biocatalyst containing a designed magnetic core and hybrid layers (organic and silicon) that allow the immobilization of enzymes, as well as the validation of the model through its effectiveness in a specific reaction of aroma ester synthesis.

**Stage 1** (2017, 12 months) – Development of a new multilayer magnetic biocatalyst

**Stage 2** (2017, 12 month) – Synthesis of natural esters in repeated cycles using the multilayer magnetic biocatalyst

### Results

The research carried out in this stage was focused on:

- development of a new multilayer magnetic catalyst by preparation of various magnetic nanoparticles;
- immobilization studies of *Candida antarctica* B lipase on these supports;
- investigation of the resulted biocatalysts in esterification reactions. Magnetic clusters functionalized with amino and carboxyl groups were obtained, and their structural, morphological and their magnetic characteristics were determined by instrumental methods, like as XPS spectroscopy. A second direction was the production of single-core magnetic nanoparticles stabilized by coating with various surfactants. These nanoparticles were thoroughly characterized by FT-IR, TEM, and XPS.

For both multi-core and single-core magnetic particles, the hydrodynamic diameters and zeta potential values have been also determined. The investigations concerning lipase immobilization included the influence of the nature and concentration of the binding agent (carbodiimide or glutaraldehyde), as well as finding of the optimal reaction conditions for covalent binding. The hydrolytic and esterification activities of the obtained biocatalysts were assayed on standard substrates.

Visit also: <http://chim.upt.ro/ro/cercetare/proiecte-de-cercetare/247-pn-iii-p2-2-1-ped-2016-0168>

#### Publications in the field of the project:

1. A. Nan, I.V. Ganea, R. Turcu, Physicochemical properties of a new magnetic nanostructure based on poly(benzofurane-co-arylacetic acid), *Analytical Letters*, accepted, DOI: 10.1080/00032719.2017.1400041
2. A. Todea, D. Aparaschivei, V. Badea, C.G. Boeriu, F. Peter, Biocatalytic route for the synthesis of oligoesters of hydroxy-fatty acids and  $\epsilon$ -caprolactone *Biotechnology Journal*, 2018, accepted.

#### Presentations at conferences:

1. R. Turcu, C. Vasilescu, A. Nan, T. Radu, I. Crăciunescu, A. Petran, M. Cîrcu, A. Bunge, F. Peter, Magnetic nanostructures with functional coating specifically designed for immobilization of enzymes, *2nd World Congress & Expo on Materials Science and Nanoscience*, September 25-27, Valencia, Spain.
2. C. Vasilescu, I. Benea, C. Paul, A. Todea, R. Turcu, F. Peter, Immobilization of lipase from *Candida antarctica* B by covalent binding onto magnetic supports, *New Trends and Strategies in the Chemistry of Advanced Materials with Relevance in Biological Systems, Technique and Environmental Protection*, 10th Edition, June 08-09, 2017, Timișoara, Romania.

#### Applicability and transferability of the results

This custom-made immobilized lipase will be able to catalyze the synthesis of natural esters from natural acids and natural alcohols. There is a high demand for food aroma esters recognized as naturals and the biocatalytic way is the best possibility to synthesize them. Superparamagnetic iron oxide nanoparticles (IONPs) in highly stable ferrofluid formulations will be used to fabricate functionalized magneto-responsive nanobeads for lipase immobilization, resulting in manifold reusable nanoparticle systems of high catalytic efficiency.

#### Financed through/by

Romanian Authority for Scientific Research and Innovation (UEFISCDI), project number PN-III-P2-2.1-PED-2016-0168, within PNCDI III

#### Research Center

Research Centre in Organic, Macromolecular and Natural Compounds Chemistry and Engineering

#### Research team

##### Consortium leader: University Politehnica Timișoara

Director: Prof. Dr. Eng. Francisc Peter

Members:

Dr. Eng. Anamaria Todea

Dr. Eng. Cristina Paul

Dr. Oana Marinică

Dr. Eng. Iulia Păușescu

Chem. Diana Aparaschivei (PhD student)

Chem. Corina Vasilescu (PhD student)

Biol. Horațiu Moldovan (PhD student)

##### Partner: National Institute for Research and Development of Isotopic and Molecular Technologies INCDTIM Cluj-Napoca

Responsible: Dr. Rodica Turcu

Dr. Alexander Bunge

Dr. Monica Cîrcu

Dr. Izabella Crăciunescu

Dr. Alexandra Nan

Dr. Anca Petran

Dr. Teodora Radu

#### Contact information (Ex)

Prof. Francisc PETER, PhD

Faculty of Industrial Chemistry and Environmental Engineering

Department of Applied Chemistry and Engineering of Natural and Organic Compounds

C. Telbisz str. 6, 300001 Timișoara, Romania

Phone: (+40) 256 404216

Mobile: (+40) 745637530

E-mail: francisc.peter@upt.ro

Web: chim.upt.ro

## SEISMIC PROTECTION OF ENGINEERING STRUCTURES THROUGH DISSIPATIVE BRACES OF NANO-MICRO MAGNETO-RHEOLOGICAL FLUID DAMPERS – SEMNAL-MRD

### Goal of the project:

The goal of the project is to develop a seismic protection system, which uses magneto-rheological fluid (MRF) dampers, acting as semi-active structural control system. Particular objectives are:

- To develop nano-micro MRF compatible with application in seismic MR dampers;
- To design and built a 10tf capacity MR damper;
- To provide type tests, based on EN 15129-2009: Anti-seismic devices, aimed to validate, calibrate and model the damper;
- To design, execute and test a brace-damper assembly in order to validate the integration of damper and brace, including connections;
- To propose structural application schemes for implementation in practice of semi-active control brace-MRD systems.

### Short description of the project:

There are three strategies for the seismic protection of structures:

- reduce seismic demands,
- enhance structural damping,
- use active or semi-active structural control.

The current project involves the third approach focusing on semi-active systems. Semi-active devices have properties that can be adjusted in real time but cannot inject energy into the controlled system. Many of them can operate on battery power alone, proving advantageous during seismic events when the main power source to the structure may fail. The most promising devices suitable for implementation into a semi-active control appear to be magneto-rheological (MR) dampers, which succeed in overcoming many of the expenses and technical difficulties associated with other types of semi-active devices.

Response characteristics of MR devices can be changed by varying the magnetic field through different current inputs. In addition to its small power requirement, the MR damper can transfer large forces at low velocities. Currently there are MR dampers with capacities up to 200 kN and research results proved the possibility to obtain capacities up to 400-500 kN.

### Project implemented by

The Research Centre for Mechanics of Materials and Structural Safety – CEMSIG, Politehnica University of Timișoara.

### Implementation period:

01.07.2014 – 30.09.2017

### Main activities:

The activities of the project were divided in four stages (I/2014, II/2015, III/2016, IV/2017). All stages are completed.

As part of stage IV/2017, the main activities were:

- testing of MR damper of 10tf capacity,
- testing of the brace-damper assembly,
- numerical modelling of single- and multi-degree of freedom systems.

The MR damper was tested under different loading conditions. Experimental investigations were performed on two buckling restrained braces (BRBs), under both monotonic and cyclic loading conditions. In addition, tests were performed also on the brace-damper assembly, since the dampers in structural systems will be coupled with braces. A control unit was used for the control of the magneto-rheological damper.

### Results:

The results of the fourth stage (IV/2017) comprised:

- several testing phases of the MR damper and adjustments for the improvement of the response;
- experimental and numerical investigations of the buckling restrained braces;
- experimental investigation of the brace-damper assembly.



The experimental tests have demonstrated the functionality of this system, but in order to optimize the way it works - there are several aspects of detail to be solved. The functionality of the hybrid system has been demonstrated in the sense that it has highlighted how the dampers work in a first phase, then by electronic control at the work capacity, the damper was blocked and the buckling restrained brace was operating.

### Applicability and transferability of the results:

Considering the seismicity of Romanian territory and the effectiveness of the dissipative devices targeted in the project (once under fabrication, the implementation in new and existing structures would be quite easy), the national market potential is very large. On the other hand, this market can comprise all the Balkan's area, including Turkey and Greece, with development potential towards neighboring Asian Countries.

### Financed through/by

The project is supported by a grant of the Romanian National Authority for Scientific Research, CNDI-UEFISCDI, project Nr. 77 / 2014 (PN-II-PT-PCCA-2013-4-1656).

### Research Center

The Research Centre for Mechanics of Materials and Structural Safety – CEMSIG, Politehnica University of Timișoara.

### Research team

- UPT – Politehnica University of Timișoara (project coordinator)
- S.C. ROSEAL S.A.
- IMS-AR – Institute of Solid Mechanics of the Romanian Academy
- AR-FT – Timișoara Branch of the Romanian Academy
- S.C. TITAN S.A.

### Contact information

Acad.Prof.dr.ing. Dan Dubină & Dr.ing. Cristian Vulcu  
Department of Steel Structures and Structural Mechanics,  
Faculty of Civil Engineering  
Politehnica University of Timișoara  
e-mail: dan.dubina@upt.ro : cristian.vulcu@upt.ro  
tel: (+40) 256 403 920

## IMPLEMENTATION INTO ROMANIAN SEISMIC RESISTANT DESIGN PRACTICE OF BUCKLING RESTRAINED BRACES (IMSER)

### Goal of the project:

The project aimed at developing a set of typical buckling restrained braces in view of their pre-qualification. Both “conventional” and “dry” devices were considered, with capacities corresponding to typical steel multistorey buildings in Romania. This should lead to a wider adoption of buckling restrained braced frames in design practice, which currently is precluded by the proprietary character of braces, need for their experimental qualification and lack of experience.

### Short description of the project:

The project developed, investigated numerically, tested and prequalified a set of buckling-restrained braces.

### Project implemented by

- Politehnica University of Timisoara (coordinator);
- SC Popp & Asociații SRL, Bucharest;
- SC HYDOMATIC SISTEM SRL, Timisoara.



### Implementation period:

01.07.2014 – 30.09.2017

### Main activities:

- Development of two different types of BRB prototypes: “conventional” and “dry”, followed by a prequalification testing program on a set of BRBs of different capacity.
- Transfer of the “know-how” on design and production of two types of BRBs to the industrial partner, who will be able to set up quantity production of these devices.
- Development of design guidelines for buckling restrained braces (at the device level). It allows production of generic BRBs by local producers at more competitive prices than imported ones.
- Development of design guidelines and design examples for steel BRB frames (at system level).
- Dissemination of the project outcomes to practising engineers.

### Results:

- Prototype structures (MRFs, BRBFs, D-BRBFs, and CBFs), located in Bucharest and Timisoara were designed. Two typical BRB capacities were selected (300 kN, respectively 700 kN).

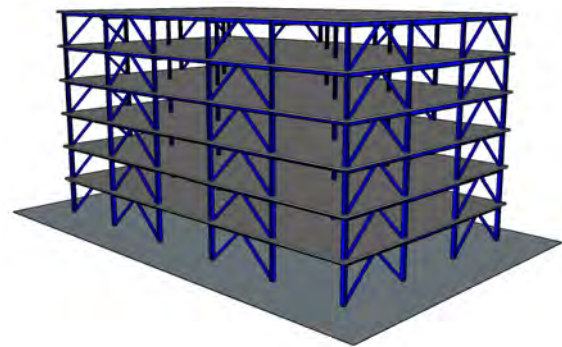

- Seismic performance evaluation of structures was performed using nonlinear static analyses for different seismic performance levels.
- Different BRB concepts were analysed and numerically tested.

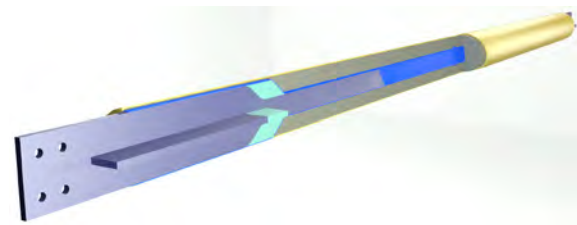

- 14 BRB specimens were manufactured and tested experimentally under cyclic loading. Their performance was assessed in terms of force adjustment factors and cumulative inelastic deformations.



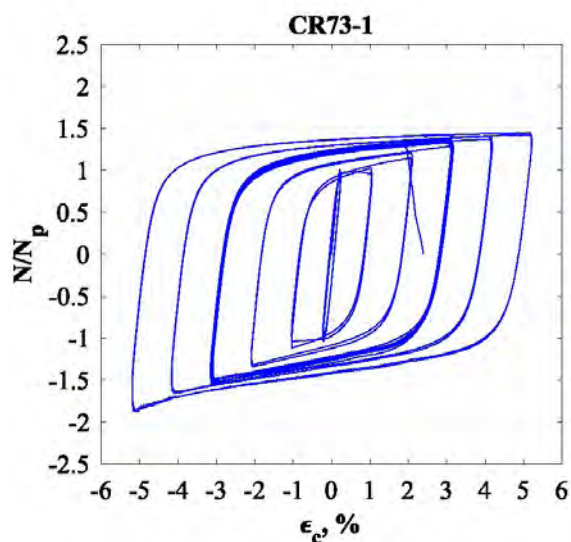

- Design guidelines were developed for prequalified BRBs and for steel buckling-restrained braced frames.
- Two workshops were organised (in Timisoara and Bucharest) in cooperation with the Association of Structural Engineers (AICPS), Politehnica University of Timisoara (UPT) and Technical University of Civil Engineering Bucharest (UTCB) for dissemination of project results.



- Research reports and design guidelines developed within the project are available at <http://www.ct.upt.ro/centre/cemsig/imser.htm>.

### Applicability and transferability of the results:

Prototype BRBs were fabricated within the project by one of the partners (SC Hydomatic Sistem SRL). Design guidelines for buckling restrained braces (device level) and for steel structures using BRBs (system level) were developed. Moreover, BRBs were prequalified for capacities in the range of 150-840 kN. It allows structural designers to easily apply this modern structural system in practice. On the other hand, the developed procedure for design of BRBs allows local manufacturing of these devices.

### Financed through/by

The project was supported by a grant of the Romanian National Authority for Scientific Research, UEFISCDI, project Nr. 99 / 2014 (PN-II-PT-PCCA-2013-4-2091).

### Research Center

CEMSIG - The Research Center for Mechanics of Materials and Structural Safety

### Research team

Assoc.prof. Aurel Stratan  
 Drd. Ing. Ciprian Zub  
 Prof.dr.ing. Florea Dinu  
 Acad. Dan Dubina

### Contact information

Assoc. prof. Aurel STRATAN  
 Faculty of Civil Engineering,  
 Department of Steel Structures and Structural Mechanics  
 Str. Ioan Cărea nr. 1  
 300224 Timisoara, Romania  
 Phone: (+40) 256 403 923  
 Mobile: (+40) 746 161 762  
 E-mail: aurel.stratan@upt.ro  
 Web: <http://www.ct.upt.ro/centre/cemsig/imser.htm>

## EXPERIMENTAL VALIDATION OF THE RESPONSE OF A FULL SCALE FRAME BUILDING SUBJECTED TO BLAST LOAD - FRAMEBLAST

### Goal of the project

The main goal of the FRAMEBLAST project is to provide an accurate validation of the response of a full scale building structural frame system under internal and external blasts in laboratory environment. The structure is subjected to internal and external blasts from different charge weights and locations (standoff, height above ground), resulting in different loading scenarios.

### Short description of the project

Explosions produced in urban areas by the detonation of high explosives are low-probability, but high-risk events. When they occur in the immediate vicinity of buildings, the explosions can affect their structural integrity (local/global failure) and harm people (injuries, death). Because the blast threat can only be mitigated, the risk can be reduced by reducing the exposure and vulnerability (enhanced local strength, allow the development of alternate load paths to prevent progressive collapse).

### Project implemented by

The project is implemented by a partnership between POLITEHNICA UNIVERSITY TIMISOARA, project coordinator Prof.dr.ing. Florea Dinu and NATIONAL INSTITUTE FOR RESEARCH AND DEVELOPMENT IN MINE SAFETY AND PROTECTION TO EXPLOSION INSEMEX Petrosani, represented by dr.ing. Attila Kovacs. External experts from TECHNICAL UNIVERSITY of CLUJ-NAPOCA and URBAN-INCERC Cluj-Napoca are also involved.

### Implementation period

2017-2018

### Main activities

- Preliminary analysis, design and fabrication of full scale experimental model
- Experimental tests on full-scale building model under internal blast. Explosive charges are detonated in different locations to acquire information about blast pressure decay and interaction with the structure
- Experimental tests on full-scale building model under external blast. First explosive charges are detonated in different locations to acquire information about blast pressure decay and interaction with the structure. Second test series use increasing explosive charges (charge weight / standoff distance) to cause the column in proximity to fail.
- Validation of a numerical model using Extreme Loading for Structures (Applied Science International, LLC, ASI).
- The development of a procedure to apply structural identification to components of a full-scale building structure with structural damage resulting from the blast pressure.

### Results

#### 1. Construction phase

- The structure components were brought to the construction site and assembled on-site using bolted connections
- Preliminary internal blast testing were performed using small charge weights (121 g cartridge of explosive)

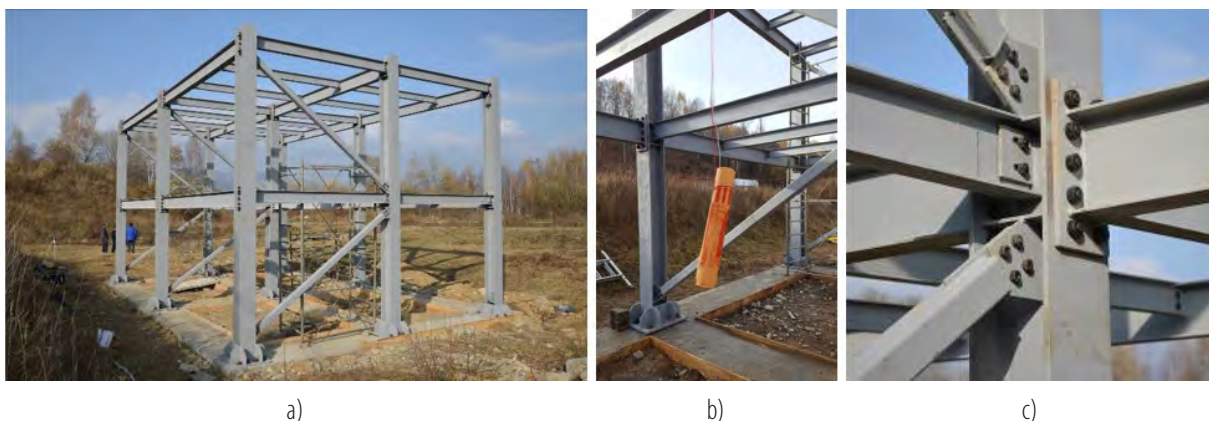

Fig. 1 Views with the experimental model:  
a) general view; b) view from inside with the position of a test blast charge; c) detailed view of a connection.

2. Experimental modal analysis to assess the dynamic properties of the structure (Bruel & Kjaer vibration measurement technology and equipment)
  - Experimental modal analyses (EMA) were carried out using hammer excitation and 11 accelerometers
  - The modal parameters were verified using the Modal Assurance Criterion (MAC)

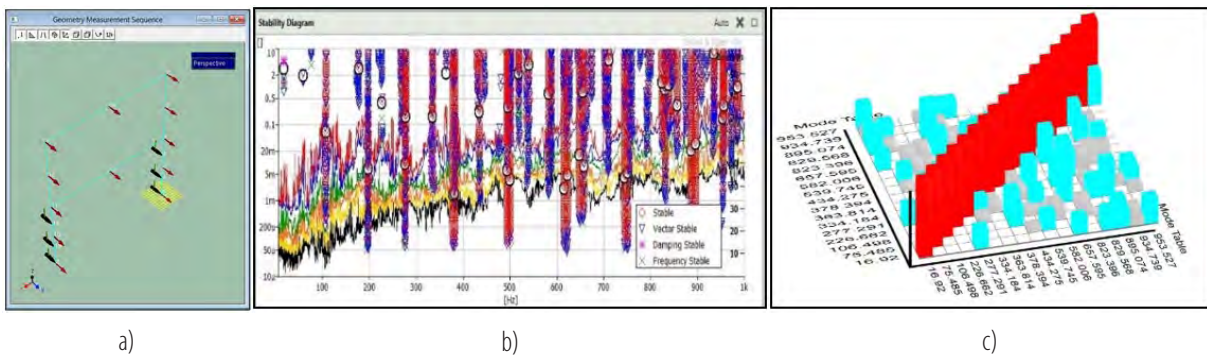

Fig. 2 Modal parameter identification: a) position of the accelerometers and MTC hammer; b) stability diagram; c) modal assurance criterion MAC

3. Preliminary numerical testing using models calibrated against bunker tests
  - Blast tests performed on two identical 3D specimen were extracted from a typical moment resisting steel frame structure
  - They allowed to make a preliminary calibration of the numerical model of a full scale building structural frame system
  - Numerical simulations were performed to evaluate the consequences of close-in detonations on the structural elements



Fig. 3 Numerical simulations using ELS:

- a) 3D view of the model tested against external blast; b) relevant blast test inside bunker; c) - d) simulation of local damage for two blast loads

### Applicability and transferability of the results

- Experimental validation of an integrated building system in laboratory environment represents the bridge from the scientific research to practical application (structural engineering).
- Experimental database and numerical models are used to upgrade the existing codes for structural design and prevention measures

### Financed through/by

This work was supported by a grant of the Romanian National Authority for Scientific Research and Innovation, CNCS/CCCDI - UEFISCDI, project number PN-III-P2-2.1-PED-2016-0962, within PNCDI III: "Experimental validation of the response of a full-scale frame building subjected to blast load" - FRAMEBLAST (2017-2018).

### Research Centre

The Research Center for Mechanics of Materials and Structural Safety - CEMSIG

### Research Team

Prof.dr.ing. Florea DINU (Coordinator)	As.dr.ing. Calin NEAGU
Prof.dr.ing. Dan DUBINA,	Conf.dr.ing. Aurel STRATAN
- membru al Academiei Romane	Prof.dr.ing. Raul ZAHARIA
As.dr.ing. Ioan MARGINEAN	Prof.dr.ing. Marin MARIN
Prof.dr.ing. Adrian CIUTINA	Dr.ing. Florin MIRON

### Contact information

Prof. Florea DINU, PhD  
 Faculty of Civil Engineering/Department of Steel Structures and Structural Mechanics CMMC  
 Address: Str. Ioan Curea 1, 300224, Timișoara  
 Phone: (+40) 256 403 912  
 Mobile: (+40) 722 460 349  
 E-mail: florea.dinu@upt.ro  
 Web: www.ct.upt.ro/centre/cemsig/frameblast.htm



## FAST WELDING COLD-FORMED STEEL BEAMS OF CORRUGATED SHEET WEB (WELLFORMED)

### Goal of the project

The main aim of the project is to test and validate a NEW technological solution for built-up cold-formed steel beams (CWB), with corrugated sheet webs and built-up cold-formed steel flanges, using Spot welding (SW) or Cold Metal Transfer (CMT) connecting technologies.

### Short description of the project

The advances in cold-formed steel structures require not only material savings but also high efficiency of production and manpower reduction. The WELLFORMED research project proposes to study a new technological solution for built-up beams made of corrugated steel sheets for the web and thin-walled cold-formed steel profiles for the flanges, connected by SW or CMT welding. Within the research project, the experimental work includes tensile-shear tests on the lap joint spot-welded specimens, were different combinations of steel sheets with various thicknesses were tested and, tests on full scale beams in bending. The study intends to demonstrate the feasibility of the proposed solutions, to assess their performance and to enlarge the knowledge by using numerical simulations for the optimization of the current solution and to define the limits of applicability of the solution.

### Project implemented by

CEMSIG - The Research Center for Mechanics of Materials and Structural Safety - Research and Technical Development unit of Politehnica University Timisoara, at the Faculty of Civil Engineering, Department of Steel Structures and Structural Mechanics.

### Implementation period

03.01.2017-02.07.2018

### Main activities

- design and fabrication of experimental program;
- experimental program on welded connections (SW and CMT) and optimisation of fastening technology;
- experimental program on full scale CWB beams, using SW or CMT connecting technologies;
- numerical investigation of beams and parametric investigations:
  - calibration of numerical models by experimental tests;
  - optimization of technical solutions;
  - design and numerical analysis of specimens with larger spans;
- design guidelines and recommendations for fabrication.

### Results

- experimental results on tensile-shear tests on the lap joint spot-welded and CMT specimens (280 small specimens), were different combinations of steel sheets with various thicknesses were tested;
- experimental program on 5 full scale CWB beams, 2 using SW and 3 CMT connecting technologies.

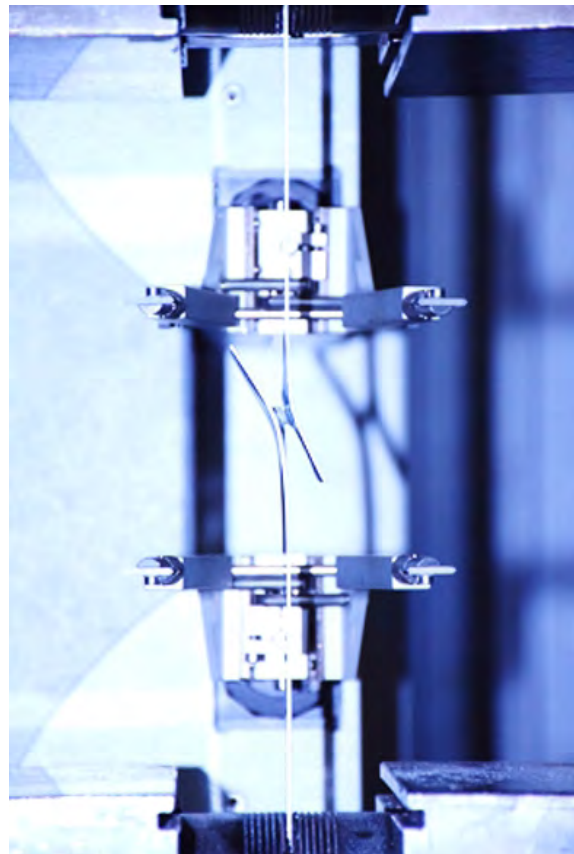

Fig. 1: Full button pull-out failure mode



Fig. 2: SW1 CWB Beam during the test

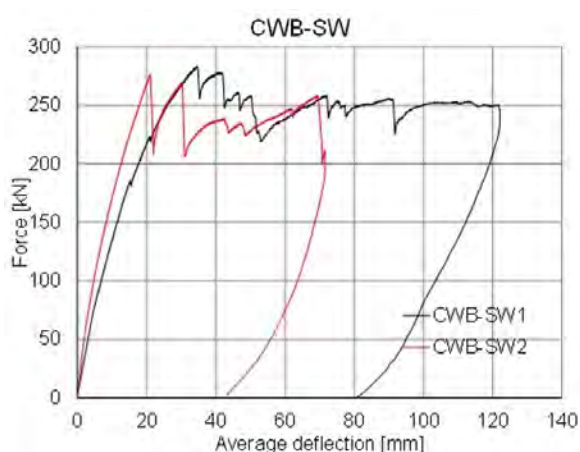

Fig. 3: Force-deflection curve for the full scale built-up beams

## Applicability and transferability of the results

The new technical solution is composed of 100% of cold-formed steel components, having high protection to corrosion, due to the fact that all components are galvanised. The solution allows for easy prefabrication, reduced erection time, mass production and high-precision quality control. All of these characteristics are expected to be interesting both for manufacturers and contractors, making steel competitive. Design guidelines and recommendations for fabrication will be provided.

## Financed through/by

The project is supported by a grant of the Executive Unit for Financing Higher Education, Research, Development and Innovation (UEFISCDI), grant agreement 57PED/2017.

## Research centre

Research Center for Mechanics of Materials and Structural Safety (CEMSIG)

## Research team

Prof. Viorel UNGUREANU, PhD  
 Acad. Dan DUBINA, PhD  
 Assoc. prof. Mircea GEORGESCU, PhD  
 Assoc. prof. Bogdan RADU, PhD  
 Sen. lect. Mircea BURCA, PhD  
 Sen. lect. Daniel TUNEA, PhD  
 Sen. lect. Ioan Both, PhD  
 Assist. prof. Neagu Calin, PhD  
 Marius GROSAN, PhD stud.

## Contact information

Prof. Viorel UNGUREANU, PhD  
 Faculty of Civil Engineering /  
 Department of Steel Structures and Structural Mechanics  
 Address: Str. Ioan Curea, No. 1, 300224, Timișoara  
 Phone: (+40) 256 403912  
 Mobile: (+40) 740 137640  
 E-mail: viorel.ungureanu@upt.ro  
[http://www.ct.upt.ro/centre/cemsig/wellformed\\_en.htm](http://www.ct.upt.ro/centre/cemsig/wellformed_en.htm)

## MICRO-SCADA SYSTEM FOR THE MANAGEMENT OF ELECTRICITY DISTRIBUTION, BASED ON A LORAWAN RADIO COMMUNICATIONS NETWORK

### Goal of the project

The project is intended to support activities of experimental development, consisting in combining and using the knowledge and multidisciplinary skills with the main aim of: designing, installing, commissioning, testing and validating a product - commercially usable prototype - consisting of a SCADA micro-system based on a LoRaWAN communications network. The project results will be the subject of the technology transfer from the service provider (UPT) to the beneficiary (MEL) in order to initiate its own capacity to develop similar systems.

### Short description of the project

The project includes activities for the design, installation, commissioning and testing of a final product - *a commercially usable prototype*: the functional SCADA micro system, based on a LoRaWAN communication network, with functions of optimizing the operation of the electrical network distribution from Straja Skiing Domain.

### Project implemented by

*SC MELIOR ELECTRO ENERGY SRL DEVA – beneficiar;  
Politehnica University Timișoara, Power Engineering Department –  
research service provider.*

### Implementation period

25.07.2017 - 24.12.2017

### Main activities

The SCADA micro system was designed as modules and components whose structures and functions are:

1. Universal radio communication module type W-COM01.LN4SEM;
2. Supply and extension I/O remote wiring module type 4DI4DO / 2RI - PS24 / 10;
3. High gain directive antenna kit for ISM band - EU 868 MHz;
4. Witness energy meter type CST 0410 - ACSMRQCL;
5. LoRa Bus for SCADA nicosistem- Reactive Power Acquisition / Compensation Command;
6. RS232 / Ethernet Module - Server Device.

The optimal configuration of the system result:

- CDA bus - LoRaWAN access role; will be done with a RS232 / Ethernet Server Device (Network Server role);
- The Application Server (Central Control Unit) will be a computer in AIO configuration and will also be installed in the CDA bus;
- CDA buses (access point) and Conx bus (Enel - 20 kV cable beginning connection point) will be connected via the radio network,
- The Conx bus will be connected to the 20/0.4 kV transformers: PT1, PT2, PT2A.

### Results

The results of the research activities carried out by the service provider will materialize in the design documentation, installation, commissioning and testing of a final product - a commercially usable prototype: a functional SCADA micro system based on a LoRaWAN communications network for the management of the electrical distribution network from Straja Skiing Domain. The main functions of the system are as follows:

- Conx bus: LoRaWAN's central node role, manages multicast messages for synchronized acquisition, provides a secure radio link with CDA (Ethernet access point); collects data from the CST0410 witness meter;
- CDA bus: access point role in the LoRaWAN network - private; uses the RS232 interface to connect to the Network Server; execution role for switching the B1 and B2 coils;
- PT1 and PT2 buses: will contain future energy meters to register the consumers connected to them.

## Applicability and transferability of the results

The results will be the subject of a technology transfer (know-how) from the research service provider (UPT) to the beneficiary (MEL) in order to initiate its own capacity to develop similar systems for the market, which will contribute to the development company and increasing its competitiveness.

## Financed through/by

Executive Agency for Higher Education, Research, Development and Innovation Funding – UEFISCDI, *Competition: PNCDI III - Program 2, Subprogram 2.1 – Innovation Checks, PN-III-CERC-CO-CI-2017.*

## Research centre

Analysis and Optimization of the Electrical Power Systems Regimes

## Research team

Assoc.prof. PhD Adrian Pană  
– Project manager;  
PhD. Student Sorin POPESCU  
– key person, Applied Electronics Department.  
Assoc.prof.PhD Florin MOLNAR-MATEI  
– Power Engineering Department;  
Lecturer PhD. Ilona BUCATARIU  
– Power Engineering Department;  
Student Florin POPESCU  
– Automation and Computers Faculty, software developer.

## Contact information

Assoc. Prof. Adrian PANĂ, PhD.,  
Electrical Power Engineering Department,  
Str. Vasile Pârvan, No. 2, 300223, Timisoara,  
Phone: (+40) 256 403 420  
Mobile: (+40) 740 275 891  
E-mail: adrian.pana@upt.ro

## INTELLIGENT DEVICE FOR CAPACITOR BANKS PROTECTION AGAINST THE EFFECTS OF HARMONIC CONDITIONS WITHIN THE ELECTRICAL DISTRIBUTION NETWORKS

### Goal of the project

Within the project was developed and tested an intelligent device for capacitor banks protection against the effects of harmonic conditions within the electrical distribution networks.

Installing a capacitor bank in a bus of an electrical network containing harmonics leads to the amplification of the harmonic conditions and to the risk of exceeding the admissible operating limits for the capacitor bank, regarding the current and voltage values, provided by the standards. The amplifications of harmonic currents or voltages can damage the capacitor. These risks can be predicted by real-time determination of the network harmonic impedance seen in the compensation bus.

Implementation of such an intelligent system will produce mainly two positive effects:

- Increasing the operational safety of the electric installations by reducing the number of capacitor bank failures.
- Reducing the costs for consumers by reducing the direct costs caused by the need to replace the damaged capacitors, and the indirect costs caused by the increased consumption of reactive power due to their out of service.

### Short description of the project

The intelligent device is based on a microcontroller and its operating principle is to determine in real time the harmonic impedance and, based on its values, to anticipate the harmonic conditions effects on the capacitor bank.

### Project implemented by

Politehnica University Timisoara – Research Service Provider  
S.C. Energomecanica Serv S.R.L. – Beneficiary

### Implementation period

25.07.2017 – 31.12.2017

### Main activities

- Elaboration of the intelligent device execution documentation
- Construction and commissioning of the intelligent device
- Testing the device operation
- Optimizing the device operation
- Protection of intellectual property rights

### Results

- The main outcome of the project is a functional experimental model and its documentation of implementation for an intelligent device for capacitor banks protection against the effects of harmonic conditions within the electrical distribution networks.
- A patent application has been filed within the project



## Applicability and transferability of the results

The project was carried out under *Check of Innovation* financing instrument which means that since from the beginning of the project the applicability and transferability of the results has been ensured. The beneficiary of the main result of the project, the intelligent device, is actually the beneficiary of the project, S.C. Energomecanica Serv S.R.L., which is an energy provider on an industrial platform. The device can also be replicated for any consumer that uses capacitor banks for power factor improving.

## Financed through/by

Executive Unit for Financing Higher Education, Research, Development and Innovation - UEFISCDI

## Research centre

Analysis and Optimization of the Electrical Power Systems Regimes

## Research team

Alexandru BĂLOI  
Florin MOLNAR-MATEI  
Claudia-Adina BOJAN-DRAGOȘ  
Alexandra-Iulia SZEDLAK-STÎNEAN

## Contact information (Ex)

Lecturer Alexandru Băloi, PhD  
Faculty/Department Address:  
Electrical and Power Engineering Faculty,  
Power Engineering Department,  
Bd. Vasile Pârvan, No. 2, Postal Code 300223, Timisoara  
Phone: (+40) 256 403428  
Mobile:  
E-mail: alexandru.baloi@upt.ro  
Web:



## TESS - THERMO-ELECTRIC HYBRID SOLAR SYSTEM

### Goal of the project

The project relates to a solar thermal - electric hybrid, which produces hot water and electricity using thermoelectric modules.

### Short description of the project

The system is composed of thermoelectric modules, and solar concentrator photovoltaic cells that convert heat to increase efficiency and reduce losses by convection, using a vacuum chamber that allows the positioning unit conversion at any position and allows adjusting the amount wastewater heat transferred by replacing hexagonal mirror solar concentrator photovoltaic.

### Project implemented by

Department of Applied Electronics, Politehnica University Timisoara

### Implementation period

03.01.2017 – 31.03.2018

### Main activities

Mechanical system implementation  
Full working prototype  
Experimental validation  
Final stage

### Results

- 2 published Journal papers (Thomson Reuters WoS) IF>1.5, Q2 and Q3
- 2 ISI Journal papers (under review)
- 8 ISI conference papers
- 2 patents

### Applicability and transferability of the results

- Effective solution for domestic use
- Tool for complex modeling, simulation and measurement
- Real time flow control

### Financed through/by

Executive Agency for Higher Education, Research, Development and Innovation Funding (UEFISCDI), Bucharest, Romania.(UEFISCDI), PN-III-P2-2.1-PED-2016-0074, 499.700 RON (110.800 EUR)

### Research centre

Intelligent Electronic Systems, <http://www.ccesi.etc.upt.ro/>

### Research team

Aurel GONTEAN  
Roland SZABO  
Szilard BULARKA  
Alexandru SFIRAT

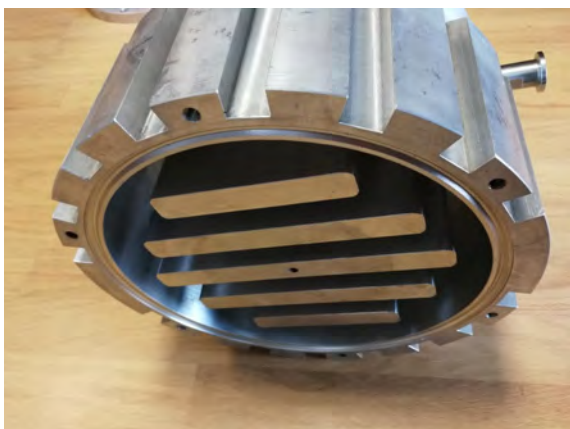

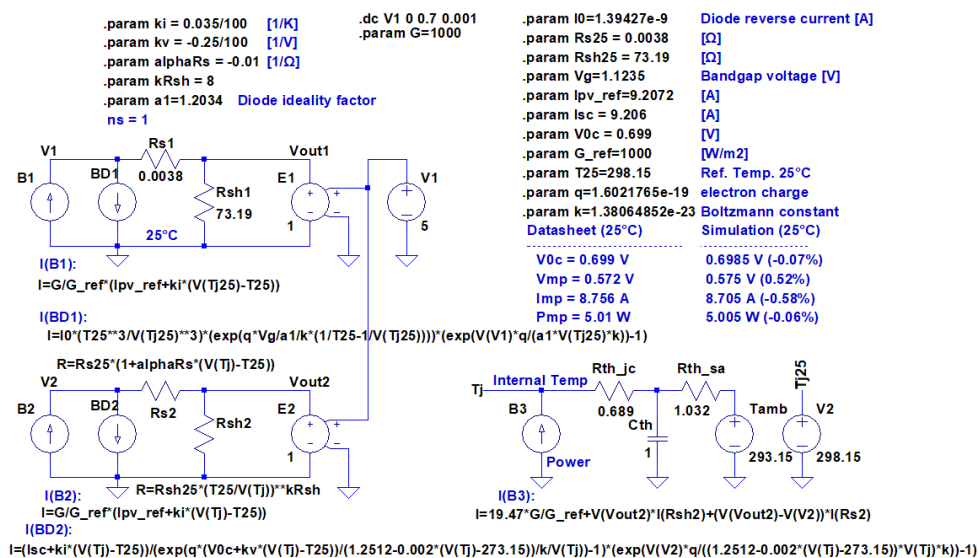

## Contact information (Ex)

Prof. Aurel GONTEAN, PhD  
 Applied Electronics Department,  
 Bd. Vasile Parvan 2, 300199, Timisoara  
 Phone: (+40) 256 403 333  
 Mobile: (+40) 745 121 383  
 E-mail: aurel.gontean@upt.ro,  
<https://sites.google.com/site/aurelgontean/home>  
<http://tess.upt.ro>



## INTELLIGENT CONTROL SYSTEM FOR CONTINUOUS CASTING BASED ON WATER FLOW CONTROL IN THE SECONDARY COOLING

### Goal of the project:

The primary objective of the research which will be made in this project is the development and implementation of the leading structure for the continuous casting process (on the secondary cooling zone) leading to eliminate quality defects and throw-outs, by adjusting the flow of the secondary cooling water. In the context of this objective it is proposed the synthesis and the development of some leading solutions for the continuous casting process using fuzzy logic, allowing to control flow of the secondary cooling water, by distribution areas. This necessity is imposed by the fact that nowadays control systems are rigid and are limited at a rigid repartition of the flow water in each area. An intelligent system has the capacity to eliminate this disadvantage of the nowadays systems by having the possibility to modify in real time this repartitions of the water flow taking into consideration what happens in the installation.

### Short description of the project:

Leaving from the installations geometry with 3 cooling areas it was create 3 fuzzy regulators for each area separately, each one having 3 inputs. After the 3 fuzzy regulators was done was designed a fuzzy adaptive system which correlates the three cooling areas so that the water flow to be the same. For example if the water flow is lowed in the first area it will automatically increase the water flow in the second and third area so that it will be the same value of the water flow but the repartition on each area will be different.

### Project implemented by

The proposed solution was implemented in the continuous casting process within S.C. Arcelor Mittal S.A. Hunedoara. The Continuous Casting Plant within the "Continuous Casting" section of the S.C. Arcelor Mittal S.A. Hunedoara is designed and manufactured by Manesman company and comprises five yarns for pipe billets with diameter  $\Phi 180$  mm,  $\Phi 200$  mm,  $\Phi 250$  mm,  $\Phi 270$  mm,  $\Phi 310$ mm or blanks for re-rolling with dimensions 240x270 mm, 310x280 mm.

### Implementation period:

01.10.2015 - 30.09.2017

### Main activities:

1. Analysis of the existing charts and databases. Practically, any continuous casting plant has a database containing the occurred events, the current operating mode and the casting recipes applied to various types of steel grades, all these leading to providing the data required to correctly approach the steps listed below.
2. Fuzzy Intelligent Systems Design. We must define the input and output variables and design the rules required to build the fuzzy controllers for each cooling area.
3. Testing and validation by simulation of the designed fuzzy controllers. Dissemination of results.
4. Realization of sensor interface for the process-driven data acquisition.
5. Software implementation of the fuzzy controllers on a PLC S7 300. The PLC is integrated in the wiring diagram of the continuous casting process. Modification of the SCADA system for observing the corrections made by the newly implemented systems.
6. PLC integration in the continuous casting plant, testing and validation of the proposed solutions, dissemination of the obtained results.

### Results:

Experiments have shown that the proposed Fuzzy solution is extremely efficient and much higher than current flow control solution, and can be implemented relatively easily on any continuous casting installation without requiring any significant changes from the hardware point of view of the existing installation.

## Applicability and transferability of the results:

Experiments were performed for 3 different profiles of the semi-finished product, namely  $\Phi 180\text{mm}$ ,  $\Phi 200\text{ mm}$ ,  $\Phi 250\text{ mm}$ , but the same mark 20MN10. On a PLC identical to the laboratory used in the "Continuous Casting" Section of S.C. Arcelor Mittal S.A. Hunedoara, the completely created program (the classical / fuzzy method) was transferred. In the first phase, the PLC only had the role of recording, storing and processing the data in order to validate its proper operation, without being able to control the flow, cooling by the classical method. After validation of the proper operation, the PLC was connected to the system (making the connection with valves), then 3 sets of castings were made using the software.

## Financed through/by

UEFISCDI

## Research Center

Faculty of Engineering Hunedoara

## Research team

Project leader:

Assoc.prof. PhD. eng. ec. Tirian Gelu-Ovidiu

Team members:

Full prof. PhD. eng. Filip Ioan

Lecturer PhD. eng. Rob Raluca

PhD's. eng. Ghiormez Loredana

PhD's. eng. Gheorghiu Csaba Attila

## Contact information

Assoc.prof. Gelu-Ovidiu TIRIAN, PhD

Faculty of Engineering Hunedoara/

Department of Electrical Engineering and Industrial Information,

Address: Revolutiei Str., No. 5, 331128, Hunedoara

Phone: (+40) 254 207 540

Mobile: +40769602413

E-mail: ovidiu.tirian@upt.ro

Web: <http://www.fih.upt.ro/personal/ovidiu.tirian/>

## PERFORMANT POWER TRAIN FOR HYBRID AND ELECTRIC VEHICLES WITH DUAL ROTOR SINGLE STATOR AXIAL SYNCHRONOUS MACHINE AND SINGLE INVERTER - HELSAX

### Goal of the project:

The project goal of bilateral cooperation between the UPT-TUIASI and UTM proposed, is of major scientific and practical importance in reducing pollution from vehicles classic using hybrid vehicles or electric drive systems performance, and aims to develop and enhance knowledge of joint research teams from Romania and Moldova, as well as enhance mobility of researchers, exchange of experience and mutual access to research infrastructure of medium and high scale, existing in the three universities.

The basic priority of the collaboration is to develop, during the implementation of the joint project, of a scientific project for participation in competitions announced by Horizon 2020 of the European Union and other international programs.

### Short description of the project:

It proposes an international original solution in which the two electrical machines (generator and motor) and static converters related are replaced by a single synchronous permanent magnet machine having axial air gap, a central stator with slots on both sides and two different windings supplied from a single PWM inverter having two output frequencies, and two independent rotors.

### Project implemented by

Politehnica University of Timisoara (UPT),  
Technical University "Gheorghe Asachi" Iași (TUIASI) and  
Technical University of Moldova (UTM)

### Implementation period:

September 2016 – March 2018

### Main activities:

The aim is to exploit the potential of joint research of the two teams for creating a system of electric drives for hybrid vehicles and electrical overall dimensions and low weight; reduce carbon emissions from vehicles; have a static converter that is simple and inexpensive; broadcast transmission system using differential electric vehicles; control of the two rotors so that they can operate in the same mode or in different modes at the same rotational direction or in opposite directions at the same speed value at slightly different speeds or at much different speeds. Specific objectives: increasing electrification of the vehicle; reducing vehicle weight; increasing the speed of operation of the electrical machine rotors for reducing the size of the actuator; sizing model for which the design (impose conditions of power, size, weight); design model for the electric drive system and the stand of experimental tests; increasing efficiency

for the electric drive system; the practical design of the machine, inverter and battery accumulators; exhibition experimental test setup; implementation and testing of the various experimental control solutions; creating an intelligent system for managing production and electricity consumption per vehicle. Expected results: a much easier vehicle with an electric drive system; low inertia rotor at high speeds; a compact electric drive system with high torque and simple control; an inverter that manages various operation modes with different speeds equal to or in the same direction or in opposite directions of the two rotors.

### Results:

The work plan in 2016 was based on regular meetings of members of both teams alternately in Romania and Moldova. First visit was in Moldova, by a team from Romania. On this occasion the Romanian members met the team members from Moldova, visited research labs, they did contact with their scientific concerns. During this movement, a conference occurred, in order to launch the project in Chisinau, where teachers and students from the Technical University of Moldova and specialists in electrical engineering enterprises in Chisinau, Balti and Tiraspol were invited .

Then followed a visit by a team from UTM to Faculty of Electrical Engineering and Energetics in Timisoara and the Faculty of Engineering Hunedoara. On this occasion contact were established with all members of the project team from Romania, were visited research laboratories of the two faculties, and there was group discussions between members of both teams according to scientific areas of joint research. One conference was organized in order to launch the project in Timisoara, where teachers and students at the University Politehnica Timisoara and specialists of enterprises of Timisoara and Arad with automotive profile were invited. There was a travel team from Chisinau to visit industrial companies in the automotive industry in Hunedoara and Deva (Lisa Draexlmaier Hunedoara, Sews Deva).

## Applicability and transferability of the results:

The motors excited by permanent magnets in a variety of designs, gaining more ground in the competition with the DC classics, because of high technical and economic achievements, especially under current conditions, in association with improved electronic supply sources and assisted computer systems that are more and more competitive. Obtaining reasonable torque values for a wide range of variation of speed, drive systems through simple procedures, are no longer a difficulty that cannot be solved. Using motors excited by permanent magnets and brushless fractional number of slots per pole and phase engines in particular, as actuators in servo-drives for low power and area, has expanded compared to the classic DC due to the progress of power electronics and information technology, without which one can not conceive an elastic system containing modern drive controllable speeds in wide range. With integrated systems for the electric drive, having adequate topologies actuators as execution elements, through the use of more evolved control algorithms and integrating functionality at both hardware and software, may lead to dynamic and superior performances, more precise control of speed or position, high electromagnetic torque, higher energy efficiency and high accuracy while simultaneously reducing overall system cost consistently. The project results will contribute to community social objectives to combat climate change. The main contribution is to reduce emissions of CO<sub>2</sub> and emissions of greenhouse gases. The project proposes new technologies and contributes to sustainable economic development.

## Financed through/by

UEFISCDI

## Research Center

UPT members of the research team are also members of the University's two research centers: the Institute for Renewable Energy and Research Centre for the intelligent control of power conversion and storage.

## Research team

The research team consists of UPT coordinator conf.dr.ing. Sorin Ioan DEACONU, teachers (PhD's): Nicolae MUNTEAN, Lucian Nicolae TUTELEA, Liviu MIHON, Octavian CORNEA, Ciprian ȘORÂNDARU, Marcel TOPOR, engineers and PhD students: Loredana GHIORMEZ and Csaba GHEORGHIU.



Informbusiness Chișinău laboratory for experimental work.



Helsax project launch conference in Chisinau.



Helsax project launch conference in Hunedoara.

## Contact information

Associate Prof. Sorin Ioan DEACONU, PhD  
Faculty/Department Address: Revolutiei Str., No. 5,  
Postal Code 331128, Hunedoara  
Phone: (+40) 254 207529  
Mobile: (+40) 744 544846  
E-mail: sorin.deaconu@fih.upt.ro  
Web: www.fih.upt.ro

## INNOVATIVE, ECOLOGIC AND EFFICIENT TECHNOLOGIES FOR JOINING METALLIC AND POLYMERIC MATERIALS USED IN AUTOMOTIVE INDUSTRY BY FRICTION STIR WELDING (INOVA-FSW)

### Goal of the project

The project is focused on studying the possibilities of using Friction Stir Welding (FSW) for joining dissimilar material (metallic and polymeric) for automotive industry. Solid state welding process, like FSW, avoid the precipitation of secondary phases in the welded joint, resulting a high quality welded joint, even between materials impossible/difficult to weld with fusion welding processes. The main goal of the project is to obtain welding technologies for joining Al-Cu, Al-Steel, as well as different polymeric materials.

### Short description of the project

The project studies the possibility to join, by FSW, Al-Cu, Al-steel and different types of polymeric materials.

### Project implemented by

The partners in this project are: University Politehnica Timisoara (UPT), National R&D Institute for Welding and Material Testing – ISIM, Timisoara, University of Pitesti and Renault Technologie Roumanie (part of the Renault Group). The last partner will also implement the results of the project.

### Implementation period

14.07.2014 – 30.09.2017

### Main activities

The main activities of the project:

- defining the materials for the welding tools, technological parameters, testing procedures and quality specifications;
- experimental studies for joining Al (and aluminum alloys) with Cu (and copper alloys) and different polymeric materials;
- experimental studies for joining Al (and aluminum alloys) with steel;
- numerical modeling of FSW welding of dissimilar materials;
- testing of welded joints, optimization of the welding procedures (building a data base with results);
- dissemination of the results.

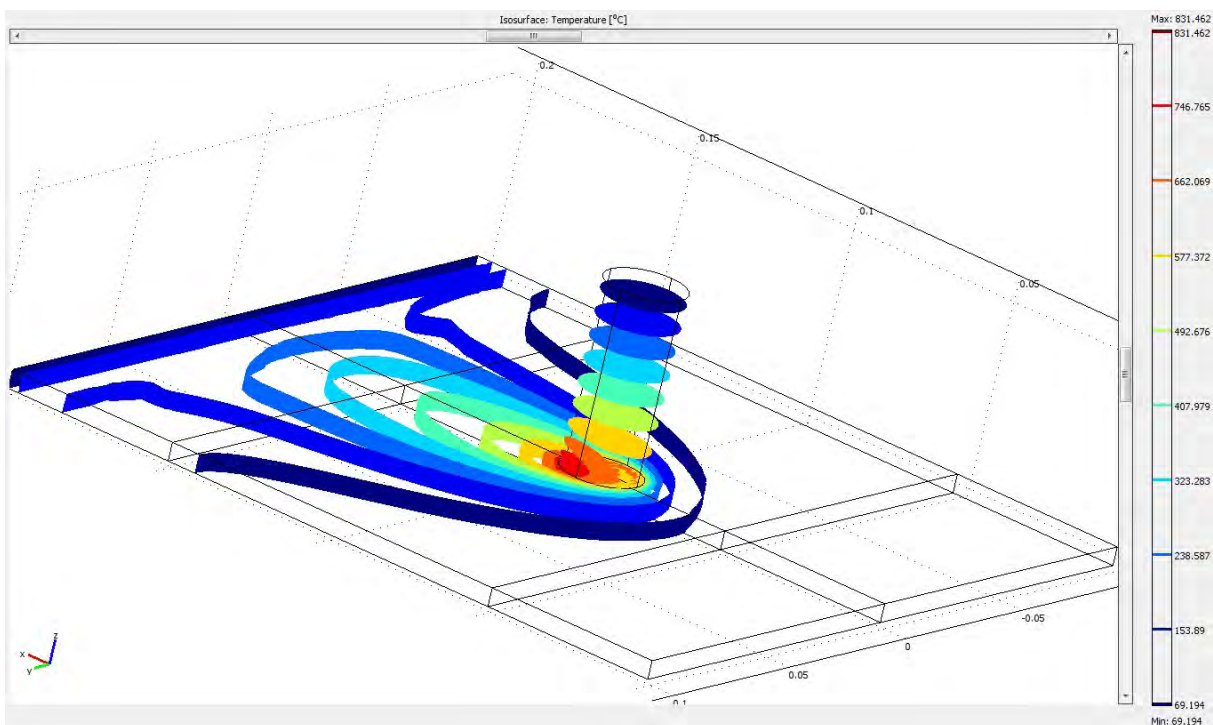

## Results

The project results are materialized in more than 10 FSW technologies (tested and certified), for joining aluminum alloys with copper alloys, aluminum alloys with steel and also different polymeric materials. Also, there were 6 scientific papers that were published, based on the results of this project.

## Applicability and transferability of the results

The result of the project will be transferred and applied mainly at the partner Renault Technologie Roumanie (part of the Renault Group), but they are available to all industrial entities working mainly in automotive industry.

## Financed through/by

UEFISCDI in grant PN-II-PT-PCCA-2013-4-1858 (Inova-FSW, contract 219/2014).

## Research Centre

ICER – Institutul de Cercetari pentru Energii Regenerabile

## Research team

University Politehnica Timisoara (UPT);  
National R&D Institute for Welding and Material Testing  
– ISIM, Timisoara;  
University of Pitesti  
Renault Technologie Roumanie (part of the Renault Group).

## Contact information

conf. Bogdan RADU, PhD  
Department Materials Engineering and Fabrication,  
b-dul Mihai Viteazul nr. 1, 300222, Timisoara  
Phone: (+40) 256 403647  
Mobile: +40746190268  
E-mail: bogdan.radu@upt.ro  
Web: <http://www.inovafsw.upt.ro/>

## KNOWLEDGE MANAGEMENT-BASED RESEARCH CONCERNING INDUSTRY-UNIVERSITY COLLABORATION IN AN OPEN INNOVATION CONTEXT (UNIINOI)

### Goal of the project

In the present competitive climate, knowledge and innovation are seen as the main distinguish factors of the organizations' success and as the basis of their competitive advantages. Following a long tradition of research in the field of innovation, open innovation is an approach in which the boundaries of innovation are shifting from a situation where organizations conduct research and development activities mainly internally, to a widespread collaboration and external knowledge source, in order to support achieving and sustaining continuous innovation of their product, services or processes. Furthermore, universities are seen among the most important partners with whom business organizations can cooperate for quantitative empirical evidence concerning the development, evolution and sustainability of Industry-University relations in Open Innovation. Despite the intensive efforts from both sides for the development of bilateral collaborations in the research and innovation field there are still space and resources for increasing the knowledge processed between these actors.

### Short description of the project

The project activities are focuses on designing a feasible strategy (based on a model and an associated methodology) for the UNlinOI together with the definition of a set or a system of key performance criteria in order to characterize this process. The validation of the whole proposed approach for the increasing of the UNlinOI is developed in the case of Romanian universities and industrial organizations. All partners in the project will support the design and validation process of the model and methodology designed solutions..

### Project implemented by

Project coordinator - University of Oradea [www.uoradea.ro](http://www.uoradea.ro)  
Partener 1 - Politehnica University of Timisoara [www.upt.ro](http://www.upt.ro)  
Partener 2 - Technical University of Cluj-Napoca [www.utcluj.ro](http://www.utcluj.ro)  
Partener 3- S.C. EMSIL TECHTRANS S.R.L. Oradea, Romania

### Implementation period

2014-2017

### Main activities

Stage I - The development of the collaborative research environment (2014)  
Stage II - The development of an Open Innovation environment between Industry-University (2015)  
Stage III - The development of a model for the performance measurement of Industry-University collaboration in Open Innovation (2016)  
Stage IV - The development of a methodology (associated with the previous designed model) for the performance measurement of Industry-University collaboration in Open Innovation (2017)

### Results

During the project implementation there have been developed the ontology of UNlinOI (Fig. 1) using an appropriate software application for the knowledge map design and visualization. The ontology representation has a tree structure that include the description of each considered item as: motivation factors, barriers, channels for the knowledge transfer, benefits and disadvantages (dimensions of the proposed ontology considered as sub-ontologies). The ontology of UNlinOI allows the analysis and optimization of the different knowledge transfer processes, activities or interdependences by considering different items depicted in each sub-ontology. Therefore, each item has been detailed, for its complete characterization using relevant, actual references and existing regulations, norms for research and development activities in Romania.



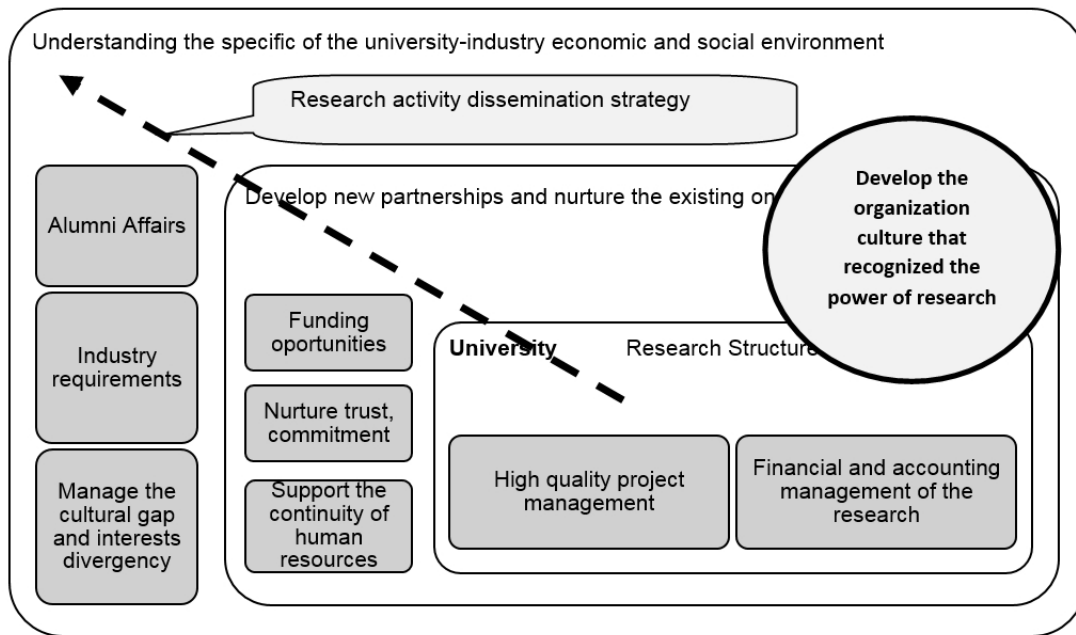

The proposed model (or framework) for the UNlinOI

## Applicability and transferability of the results

1. The projects' research results could be transferred in universities practices in order to define the strategy with its industrial partners in the local and regional areas (derived from a business model). In addition, the results could be useful for the internal procedures development and for the definition of a scientific framework in order to strength and intensify UNlinOI (including the development of future joint projects);
2. The research results could be easy transfer to industrial entities in order to foster UNlinOI;
3. Project's research results were transferred in the didactical process (master level) and enriched the knowledge bases of our didactical and PhD students' projects.

## Financed through/by

The project is supported by the Ministry of National Education through The Executive Unit for Financing Higher Education, Research, Development and Innovation in the context of Partnerships in Priority Domains Programme.

## Research Centre

Engineering and Management Research Center

## Research team

Prof. Anca DRAGHICI (project responsible)  
 Prof. George DRAGHICI  
 As. PhD. Larisa-Victoria IVASCU

## Contact information

Prof. Anca DRAGHICI, PhD  
 Faculty of Management in Production and Transportation  
 Department of Management  
 Address: Remus Str., No. 14, 300191, Timisoara  
 Phone: (+40) 256 403 610  
 E-mail: anca.draghici@upt.ro  
 Web: www.mpt.upt.ro



## THE IMPACT OF THE ECONOMIC AND FINANCIAL STABILITY ON INVESTMENTS, INNOVATION PROCESS AND ENTREPRENEURIAL ACTIVITY IN THE EU (ISIIA)

### Goal of the project

The aim of the project is to analyze the relationship between economic and financial stability on the one hand, and investment, innovation and entrepreneurship on the other hand, with a focus on the EU countries. The purpose is to see how the degradation of macroeconomic conditions and firms' access to finance influence their investment behavior and the entrepreneurial activity. For this purpose we use firm-level statistics (AMADEUS database) and perform sectorial comparison at EU level.

### Short description of the projects

The economic and financial stability plays an important role in promoting investment, in influencing the entrepreneurs' decisions and in enhancing the national innovativeness capacity. These aspects, extremely important for the European strategy for economic recovery and job creation are not sufficiently explored in the literature, while their empirical investigation is practically inexistent.

### Project implemented by

Politehnica University of Timisoara

### Implementation period

01.10.2015 – 30.09.2017

### Main activities

1. We develop the research on three directions:

- analyze the link between stability and investments, considering the sectorial particularities of the investments' determinants, using FDI and firm-level data.
- investigate the role of the stability in enhancing the national innovativeness capacity.
- explore the relationship between the economic stability and the entrepreneurial activity, to see which are the economic sectors where the entrepreneurial decision is sensitive to the evolution of the macroeconomic fundamentals.

2. Manipulation of AMADEUS statistics for firms' financial statements

3. Econometric analyses and generation of results

4. Dissemination of results in international conference

5. Collaboration with international researcher and research stages for young researchers involved in the project

6. Publication of empirical findings in high-ranked journals

### Results

Publications:

- Albulescu, C.T., Oros, C. and Tiwari, A.K. (2017). Is there any convergence in health expenditures across EU countries? *Economics Bulletin*, 37(3), 2095-2101.
- Albulescu, C.T., Aubin, C. and Goyeau, D. (2017). Stock prices, inflation and inflation uncertainty in the U.S.: Testing the long-run relationship considering Dow Jones sector indexes, *Applied Economics*, 49(18), 1794-1807.
- Albulescu, C.T., Miclea, S., Suci, S.S., and Tamasila, M. (2017). Firm-level investment in extractive industries from CEE countries: the role of macroeconomic uncertainty and internal conditions, *Eurasian Business Review*, <https://doi.org/10.1007/s40821-017-0079-3>.
- Albulescu, C.T. and Ionescu, A.M. (2017). The long-run impact of monetary policy uncertainty and banking stability on inward FDI in EU countries, *Research in International Business and Finance*, <https://doi.org/10.1016/j.ribaf.2017.07.133>.
- Albulescu, C.T. and Tiwari, A.K. (2017). Unemployment persistence in EU countries: new evidence using bounded unit root tests, *Applied Economics Letters*, <https://doi.org/10.1080/13504851.2017.1368979>.

Research Stages:

Șerban Miclea (Université de Poitiers, CRIEF)  
Claudiu Albulescu (Université d'Orleans, LEO)

## Applicability and transferability of the results

The findings have practical implications for investment and financial managers of companies operating in different economic fields. The results have also practical implication for fiscal and monetary authorities, helping them to identify the elements that enhance the investment and the entrepreneurial activity, in order to sustain the economic growth and job creation. Further, relying on a sectorial analysis, the findings give a complete understanding about the determinants of investment and entrepreneurship, specific to each industry.

## Financed through/by

Executive Unit for Financing Higher Education, Research, Development and Innovation - UEFISCDI

## Research Centre

Engineering and Management Research Centre

## Research Team

Assoc. Prof. Claudiu Albuлесcu, PhD (Principal Investigator)

Assoc. Prof. Matei Tămăşilă, PhD

Lect. Ilie Mihai Tăucean, PhD

Assist. Prof. Şerban Miclea, PhD

PhD student Bogdan Ianc

PhD student Adrian Ionescu

PhD student Simina Suci

## Contact information

Assoc.Prof. Claudiu ALBULESCU, PhD

Faculty of Management in Production and Transportation,  
Management Department,

Remus Street, no. 14, 300191, Timișoara

Phone: (+40) 256 404 035

Mobile: (+40) 743 089 759

E-mail: [claudiu.albuлесcu@upt.ro](mailto:claudiu.albuлесcu@upt.ro)

Web: <https://sites.google.com/site/isiaue/>

## ENVIRONMENTAL ENERGY HARVESTING HYBRID SYSTEM BY PHOTOVOLTAIC AND PIEZOELECTRIC CONVERSION, DC/DC TRANSFORMATION WITH MEMS INTEGRATION AND ADAPTIVE STORAGE

### Goal of the project

The design, building and testing of the prototype of a hybrid system for energy harvesting from the ambient through photovoltaic conversion, DC/DC transformation with MEMS integration and adaptive storage, will be carried out. A key novel component is the planar power micro-transformer for high frequency, with hybrid magnetic nanofluid/ferrite core and windings fabricated in MEMS technology, a part of the DC/DC converter. A second key component is the photovoltaic cell, which relies on novel solutions.

### Short description of the project

A prototype with wireless sensors powered by the harvesting system was designed, built and tested. In this endeavor, there was prepared a dedicated magnetic fluid to be used as core of a micro-transformer, designed accordingly and tested. Further, an experimental model of the energy harvesting hybrid system was elaborated, designed and tested. Finally, a prototype for the harvesting device was designed and tested for a particular application.

The 2017 year research aimed to complete the third main activity. Politehnica University team (P1) was responsible for measuring the electrical properties of the magnetic nanofluid samples used in all tests and participating to the planned testing activities and dissemination.

### Project implemented by

- National Institute for R&D in Electrical Engineering ICPE-CA Bucharest (Coordinator),
- Politehnica University of Timisoara (Partner 1),
- Romanian Academy – Timisoara Branch (Partner 2),
- Politehnica University of Bucharest (Partner 3),
- SYSCOM PROCESS CONTROL LTD (Partner 4).

### Results

The main result of the project will be the integration of an innovative photovoltaic conversion system and an original DC/DC converter, which utilizes a planar, spiral, MEMS, hybrid (magnetic nanofluid/ferrite) cored micro-transformer in an efficient device for energy harvesting. Regarding the use of a magnetic nanofluid core micro-transformer for the DC/DC converter, from the manufacturing point of view, it is expected that once the appropriate magnetic nanofluid characteristics are established, it will offer an easier way of obtaining the transformer core compared to a solid one. From the operating point of view, it is expected that by replacing the solid core with a liquid core will result in a better heat dissipation and reduction of the thermal stresses in the micro-transformer, leading to a longer life-cycle, maintaining or even improving the electric characteristics. The results obtained in 2017 were disseminated through:

### Implementation period

July 1<sup>st</sup>, 2014 – September 30, 2017

### Main activities

The main activities are as follows:

- (I) elaboration of the experimental model of the energy harvesting hybrid system by photovoltaic conversion and DC/DC transformation with MEMS integration;
- (II) design and testing of the experimental model of the energy harvesting hybrid system by photovoltaic conversion and DC/DC transformation with MEMS integration;
- (III) design and testing of the prototype of the energy harvesting hybrid system by photovoltaic conversion and DC/DC transformation with MEMS integration.

[1] Lucian Pîslaru-Dănescu, Gabriela Telipan, Floriana D. Stoian, Sorin Holotescu, Oana Maria Marinică, Chapter: Nanofluid with Colloidal Magnetic Fe<sub>3</sub>O<sub>4</sub> Nanoparticles and Its Applications in Electrical Engineering, published in book "Nanofluid heat and mass transfer in engineering problems", Editor Mohsen Sheikholeslami Kandelousi, ISBN 978-953-51-3008-6, InTech Open, Croatia, 2017, DOI: 10.5772/65556.

[2]. Oana Maria Marinică, Study of Static Magnetic Properties of Transformer Oil Based Magnetic Fluids for Various Technical Applications Using Demagnetizing Field Correction, Journal of Nanomaterials, Volume 2017, Article ID 5407679, 9 pages, Hindawi, doi.org/10.1155/2017/5407679.

[3] Vlad Socoliuc, Daniela Susan-Resiga, Corina Vasilescu, Oana Marinică, Izabell Crăciunescu, Tünde Borbáth, István Borbáth, Alin Bosioc, Sebastian Muntean, Nicolae Calin Popa, Rodica Turcu, Ladislau Vékás, Ferrofluids and nano-micro composite fluids: high magnetic response and optimized magnetorheological behaviour tailored for specific applications, presented at 2nd Global Congress & Expo on Materials Science and Nanoscience, 25 – 27 September 2017, Valencia, Spain

## Applicability and transferability of the results

The product can bring added value for further development as an end-product to the industrial partner. Possible applications are characterized by their placement in hard to reach places, isolated and without local and/or conventional sources. Among these are applications for industrial automation, monitoring of various parameters in industry (pressure transducers mounted in the gas distribution networks, device multiparameter probes mounted in drinking water distribution networks and others), in agriculture (humidity and soil temperature sensors), for surveillance and monitoring of perimeters.

## Financed through/by

Ministry of National Education through the Executive Agency for Higher Education, Research, Development and Innovation Funding, Partnerships in priority S&T domains Program PN II, Joint Applied Research Projects PCCA 2013.

## Research centre

Research Center for Complex Fluid System Engineering,  
Politehnica University Timisoara,  
URL: <http://mh.mec.upt.ro/ccisfc/>



## Research team

The research team of Politehnica University of Timisoara is consisting of three senior researchers, one PhD student and two research assistants:

Assoc. Prof. Dr. –Eng. Floriana D. STOIAN  
– Project responsible for Partner 1,  
Lect. Dr.-Eng. Math. Sorin HOLOTESCU,  
Phys. Oana MARINICA,  
Assoc.Prof. Dr.-Eng. Nicolae Crainic,  
Res. Assist. Florica BALANEAN,  
Res. Assist. George GIULA.

## Contact information

Assoc. Prof. Floriana D. STOIAN, PhD  
Department of Mechanical Machines, Technology and Transportation  
/ Research Center for Engineering of Systems with Complex Fluids,  
1 Mihai Viteazu Bv., Timisoara 300222, Romania  
Phone: (+40) 256 403671; Mobile:(+40) 744 597308  
E-mail: [floriana.stoian@upt.ro](mailto:floriana.stoian@upt.ro), [fdstoian@yahoo.com](mailto:fdstoian@yahoo.com)  
Project website:  
<http://www.icpe-ca.ro/lib/files/aseMEMS-harvest.pdf>

## VALORIZATION OF ENERGETIC POTENTIAL FOR AGRO-INDUSTRIAL RESIDUES THROUGH BIODEGRADATION PROCESSES AND CATALYTIC COMBUSTION OF OBTAINED BIOGAS

### Goal of the project

Determination of the best recipes with the help of mathematical apparatus (mathematical modeling) in accordance with the experience accumulated so far, for obtaining biogas with the best characteristics in terms of quality and quantity; testing at laboratory level (volumes between 1 and 6 liters) for substrates identified as being the most suitable for anaerobic fermentation process; for the existing pilot installation there will be made modifications for process optimization through increasing the control degree for process parameters and improvement of material homogeneity during the residence time inside the reactors. The obtained experimental values will be compared with the ones obtained from modeling processes and corresponding conclusions will be traced; biogas capitalization in catalytic firing processes.

### Short description of the project

The proposed project highlights the way different biodegradable materials can be capitalized with emphasis on agricultural, municipal and industrial residues, using anaerobic fermentation processes with biogas production. The project structures in an interdisciplinary manner lifecycle of degradable resources mentioned above, from the point of origin to the exploitation of obtained biogas using catalytic combustion. It will be used a two-pronged approach to capitalize biodegradable materials: theoretical, using mathematical models for determining the characteristics of the anaerobic fermentation process and experimental, through laboratory determinations to characterize the substrates and obtained biogas using combustion tests in order to identify the most suitable catalysts in this regard. The purpose of the project involves a novel contribution in a direction which is currently under development at national level by providing relevant information impacting the quality of life by increasing regional and local autonomy in the context of valorization the renewable energy resources. The degree of novelty for the project also involves developing an experimental pilot for testing liquid substrates in anaerobic fermentation processes, which can have further industrial applications.

### Project implemented by

Politehnica University Timisoara,  
Mechanical Engineering Faculty,  
Department of Mechanical Machines Equipment and Transportation

### Implementation period

01.10.2015 – 30.09.2017

### Main activities:

- Establishing the substrates which will be further used in experimental determinations;
- Mathematical modeling;
- Experimental tests on existing installations;
- Catalytic elements synthesis for further use in biogas combustion processes;
- Tests over the optimization possibilities for biogas combustion using catalytic elements;
- Comparison of experimental and modeling determinations.

### Results

- 2 papers published in ISI journals (Web of Knowledge);
- 2 papers published in BDI indexed journals;
- participation to at least 2 national/international conferences;
- publishing of a book or a book chapter with the obtained results.

## Applicability and transferability of the results

The project underlines the need to develop new methods of valorization for the non-usable biodegradable part through interdisciplinary approach which has as a main purpose determining the exploitation possibilities for the residual materials which originate from agriculture or municipal /industrial environment through chemical conversion processes with impact on biogas production.

Through developing and application of models for determining the best residual material sorts which are to be used in anaerobic fermentation processes and their application at pilot scale, it can be open a new research direction relative to the used models for semi - industrial or industrial scale for solving, at least partially, the energetic demand from renewable sources.

This aspect can help in regards to increased degree of energetic independence at local and regional levels with impact on life quality for the involved population of the respective areas from two points of view: reduced price for gas through input of renewable energy and increased work opportunities in case of developing respective installations in this purpose.

## Financed through/by

Romanian National Authority for Scientific Research and Innovation, CNCS – UEFISCDI

## Research Centre

MMUT / ICER

## Research team

Cioablă Adrian Eugen – director;  
Trif - Tordai Gavrilă – postdoctoral researcher;  
Lelea Dorin – researcher;  
Popescu Francisc – researcher;  
Dumitrel Alina Gabriela – researcher;  
Vodă Raluca – researcher;  
Țenchea Adrian – researcher;  
Milotin Roxana – PhD Student;  
Lucia Ana Varga – PhD Student.

## Contact information

Sl.eng. Adrian Eugen CIOABLĂ, PhD  
Mechanical Engineering Faculty /  
Department of Mechanical Machines Equipment and Transportation,  
Address: Mihai Viteazu Blv, No. 1, Postal Code 300222, Timișoara  
Phone: (+40) 256 403746  
Mobile: (+40) 728 123 289  
E-mail: adrian.cioabla@upt.ro  
Web: www.upt.ro

## MITIGATION OF DECELERATED SWIRLING FLOW FROM CONICAL DIFFUSERS USING PULSATING WATER JET

### Goal of the project:

The fundamental problem addressed in this project is studying a new control method of decelerated swirling flow. The main goal of this project is to evaluate numerically and experimentally the performance of a new flow control method with pulse water injection. The first goal of the project is to mitigate the low frequency plunging oscillations using axially-injected pulsation jets. The second goal is to minimize the injected discharge during this control. This project attempts to deliver answers to the following questions: Is the pulse water injection a valid control method from experimentally point of view? What is the pulse jet parameters which allow the mitigation/elimination of the VR and the maximum pressure recovery in the cone and what is the optimal jet's discharge value? Are there any technical and economical limits of this method? Which are the advantages (if any) of this method with respect to the previous ones (the jet and hydrodynamic feedback)? Which are the disadvantages (if any) of this method with respect to the previous ones (the jet and hydrodynamic feedback)? An existing test rig from Politehnica University of Timisoara is going to be used for experimental investigation of this method (Fig. 1).



### Short description of the project:

The new control method consists in injecting a pulsating axial water jet in order to mitigate the low frequency plunging oscillations. The idea of using pulsating jets is yielded by the measured pressure's low-frequency oscillation in the conical diffusers of hydraulic turbines which are operated at part load. These regimes are imposed by the power network requirements. The fixed blade turbines e.g. Francis type, operating at part load present a high level of swirling

flow at the inlet of draft tube. When swirling flow from draft tube is decelerating, it becomes unstable giving rise at helical vortex (or vortex rope). Vortex rope is the main cause for the occurrence of pressure fluctuations in draft tube of hydraulic turbines operating at part load. Mitigating the vortex rope phenomenon is an open problem for modern Francis hydraulic turbines. Numerous techniques have been examined for reducing these effects, with success varying widely. Two types of pressure fluctuations associated with the draft tube surge are identified in the literature. The first is an asynchronous pressure fluctuation due to the precession of the helical vortex around the axis of the draft tube. The second type is synchronous fluctuations who give rise to power fluctuations. Consequently, these low-frequency pressure oscillations will be mitigated using the pulsating axial jet control method.

### Project implemented by

Politehnica University Timisoara, Research Center for Engineering of Systems with Complex Fluids

### Implementation period:

01.10.2015-30.09.2017

### Main activities:

- 1) Objective I: 3D numerical analysis of swirling flow using pulsating jet injection method,
- 2) Objective II: Manufacturing and implementing on the rig of Rotating Pulsating Jet Device,
- 3) Objective III: Experimental campaign for pulsating jet parameters optimization,
- 4) Objective IV: Validation of experimental vs. numerical data.



## Results:

The results for 2016 are presented in the list of papers:

1. C. TANASA, T. CIOCAN, S. MUNTEAN and R. SUSAN-RESIGA, (2016), Numerical Assessment of Decelerated Swirling Flow with Vortex Rope from Conical Diffuser Using Pulsating Water Jet, 19th International Seminar on Hydropower Plants, Vienna, 09-11, November.
2. SUSAN-RESIGA Romeo-Florin, MUNTEAN Sebastian, TĂNASĂ Constantin, BOSIOC Ilie Alin, CIOCAN Tiberiu, POPESCU Constantin, (2016), ECHIPAMENT PENTRU CONTROLUL INSTABILITĂȚILOR CURGERILOR CU VĂRTEJ DIN DIFUZORUL CONIC AL TURBINELOR HIDRAULICE, patent application no. A0038/12.05.216 - in romanian.

## Applicability and transferability of the results:

A new control method is promoted in this project which attempt to improve the flow control and mitigate the axial pressure pulsations revealed by previous investigations. The decelerated flow control using pulsating jets is a new idea. This new control method will mitigate the low frequency pressure pulsations. These plunging oscillations are dangerous due to the waves traveling along to hydraulic passage. This project will evaluate numerically and experimentally the performance of a new decelerated flow control method: using pulse water injection. Decelerated flow control is a problem experienced by hydraulic turbines when operating far from their best efficiency point as a request from energy market demands. Operating in such a regime (if even possible) causes severe vibrations, efficiency decrease, material fatigue, breaks blades etc. Implementation of a decelerated flow control system able to eliminate vibrations leads to maintenance and operation costs decrease. The method which will be tested on the experimental test rig will be proposed for using in real power plants from the national company SC Hidroelectrica SA Romania, which is partner in different contracts in the field of hydraulic machinery with our institution.

## Financed through/by

Unitatea Executiva pentru Finantarea Invatamantului Superior, a Cercetarii Dezvoltarii si Inovarii UEFISCDI

## Research Center

Research Center for Engineering of Systems with Complex Fluids

## Research team

1. Tanasa Constantin, Director de Proiect
2. Ciocan Tiberiu, Cercetator Postdoctoral
3. Bosioc Ilie Alin, Cercetator Postdoctoral
4. Popescu Constantin, Student Doctorand
5. Predoiu Ionut-Costinel, Student Doctorand
6. Mos Daniel, Student Masterand
7. Muntean, Sebastian, Cercetator Senior
8. Todiruta Mariana, Cercetator Senior
9. Szakal Raul-Alexandru, Student Masterand

## Contact information

Dr. Constantin TANASA, CSIII  
Mechanical Engineering Faculty/Hydraulic Machinery Department,  
Address: M. Viteazu, No. 1, Timisoara  
Phone: (+40) 256403692  
E-mail: constantin.tanasa@upt.ro  
Web: <http://mh.mec.upt.ro/RPJD-DJPR/#/login>

## INCREASING COMPETITIVENESS OF COLTERM BY OPTIMIZING VARIABLE SPEED CONTROL TECHNOLOGY OF LARGE POWER CENTRIFUGAL PUMPS FOR HEATING

### Goal of the project

The objective of this project is to integrate the new modern assemblies pump–electric motor–converter with variable speed control technology in the transport network of the thermal energy from Timisoara and the efficient operation of the entire transport network of the thermal energy.

### Short description of the project

The objectives of this project are the integration of the two modern assemblies in the transport network of the thermal energy from the city of Timisoara together with the efficient operation of the entire heating network. To achieve these objectives an experimental investigation will be carried out for the designated pumps from the transport system of the thermal energy from the two CET in order to obtain characteristic curves of operation.

### Project implemented by:

The project is implemented by a team from the Politehnica University Timișoara.

### Implementation period

30/09/2016 – 30/09/2018

### Main activities

There are three main activities.

The first one is to determine a protocol for experimental investigation of centrifugal pumps and to apply it on a couple of pumps from the Laboratory of Hydraulic Machines.

The second one is to investigate the pumps from CET Centru and establish the best operating pattern for these pumps.

The third one is to investigate the pumps from CET Sud and establish the best operating pattern for these pumps.

### Results

The estimated results of this project are the operating patterns of the centrifugal pumps from CET Centru and CET Sud and the best efficient operating pattern of these pumps. Until now, the pumps from CET Centru were investigated and the results are presented in the next three figures. In the first figure, we have the operating curves of the four centrifugal pumps from CET Centre. In the second figure, we have the best operating pattern for these four pumps.

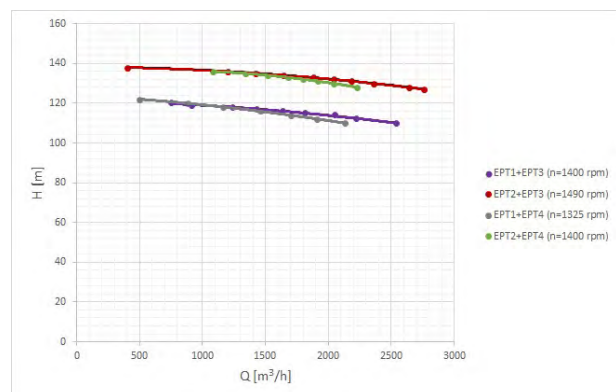
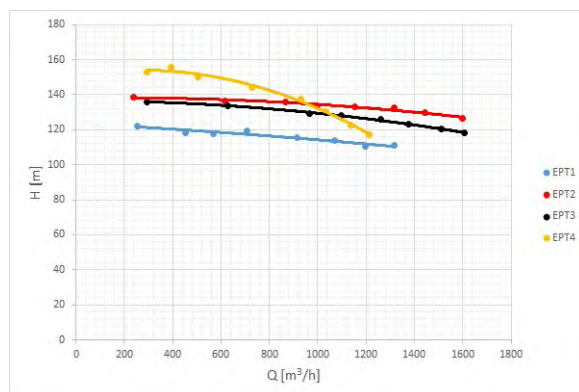

## Applicability and transferability of the results:

The best operating patterns of the centrifugal pumps from CET Centru and CET Sud will help Colterm to operate these pump at best efficiency in order to supply the necessary domestic hot water and thermal energy for the citizens of Timisoara. By doing this, Colterm will optimize the cost with electric energy.

## Financed through/by

CNCS – UEFISCDI, project number 69BG/2016/, project code PN-III-P2-2.1-BG-2016-0190

## Research Center

Research Centre for Complex Fluid Systems Engineering

## Research team

Assoc. Prof. Adrian STUPARU, PhD,  
Prof. Alexandru BAYA, PhD,  
Prof. Liviu ANTON, PhD,  
Asist. Prof. Alin BOSIOC, PhD,  
Eng. Mariana TODIRUȚĂ,  
Eng. Daniel MOȘ

## Contact information

Conf. Adrian STUPARU, PhD  
Faculty/DepartmentAddress:  
Bvd. Mihai Viteazu, No. 1, 300222, Timișoara  
Phone: -  
Mobile: 0744 642 076  
E-mail: [adrian.stuparu@upt.ro](mailto:adrian.stuparu@upt.ro)  
Web: <http://mh.mec.upt.ro/opexpc>

## IONOSPHERIC PROPAGATION PREDICTIONS AND WIDEBAND COMMUNICATIONS USING HF SDR SENSORS FOR INFORMATIONAL SUPPORT IN EMERGENCY SITUATIONS IN ROMANIA

### Goal of the project

The project aims to implement software and hardware solutions that integrate ionospheric sounding algorithms in a network of SDR (Software Defined Radio) sensors in order to develop and validate a HF (High Frequency) ionospheric prediction model for the territory of Romania.

### Short description of the project

The project targets a systemic approach of the communication network through the implementation, development and integration of recent technological solutions from the perspective of providing information support for the management of interventions in disaster areas where communication infrastructure does not exist or is damaged. Project results can be applied not only in the rapid resolution of remote communications in emergency situations, but also can be extended to other applications in the HF communications range, such as encrypted data communication links for the government or the military.

### Project implemented by:

- Land Forces Academy "Nicolae Bălcescu", Sibiu - coordinator
- Interactive Systems & Business Consulting, Bucharest - partner
- Politehnica University Timișoara - partner
- Technical University of Cluj-Napoca - partner

### Implementation period

21.11.2014 - 30.09.2017

### Main activities

- Building a SDR sensor network for ionospheric sounding
- Elaboration of an application for HF propagation predictions in Romania.
- Development of broadband HF communications by the implementation of adaptive systems



HF antenna

### Results

The main deliverables of the project are:

- an ionospheric model which is specific for Eastern Europe;
- algorithms for the automatic identification and classification of waveforms in order to increase the transfer rate and to implement techniques for dynamically accessing the HF resources;
- SDR solutions for local monitoring and collaborative spectrum sensing in the HF range;
- a HF radio network on the territory of Romania which allows high transfer rates in collaborative environments, by automatically adapting to specific conditions of ionospheric propagation at high angles of elevation.

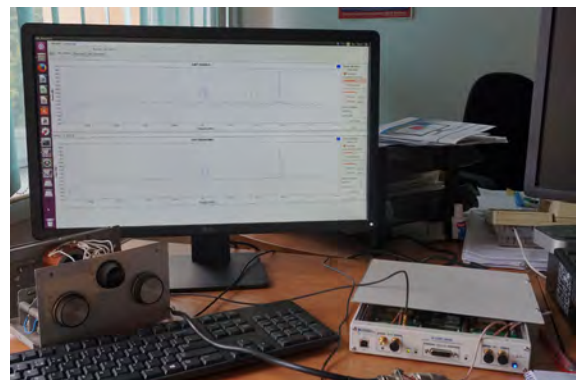

Experimental setup

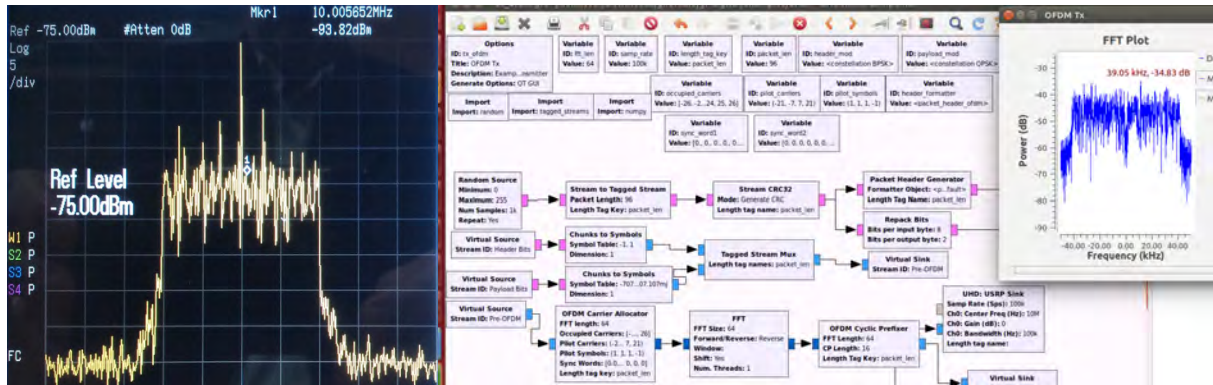

OFDM signal

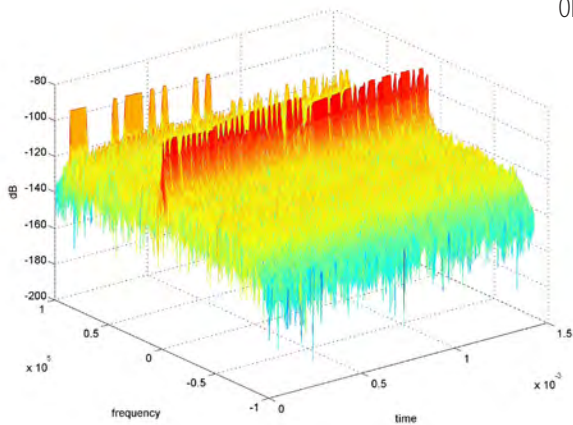

Time-Frequency representation of the HF signal

### Short Time Duty Cycle

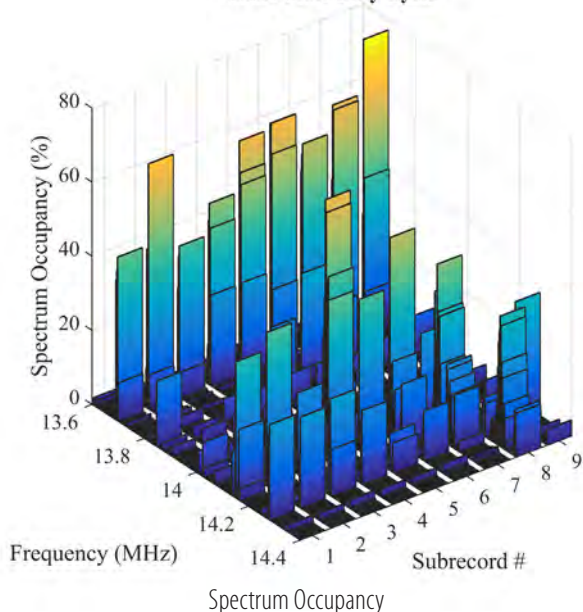

## Applicability and transferability of the results

- creating an integrated software application for HF propagation predictions adapted to the propagation particularities of our country
- implementing the ionospheric measurement capability for HF radio stations with SDR architecture
- measurement and modeling of Spectrum Occupancy in the HF range
- implementing algorithms for the adaptation of broadband waveforms to the ionospheric channel status
- implementing an integrated system for monitoring the ionosphere

## Financed through/by

PN-II-PT-PCCA-2013-4

## Research Centre

ICER

## Research team

Prof. dr. eng. Aldo De Sabata  
 Assoc. prof. dr. eng. Septimiu Mischic  
 Assist. lect. dr. eng. Cornel Balint  
 Assist. lect. dr. eng. Ciprian Dughur  
 Assist. lect. dr. eng. Cora Iftode

## Contact information

Prof. Aldo DE SABATA, PhD  
 Faculty of Electronics, Telecommunications and Information Technology,  
 Bd. Vasile Pârvan, No. 2, Postal Code 300223, Timișoara  
 Phone: (+40) 256 403 370  
 Mobile: 0745708338  
 E-mail: aldo.de-sabata@upt.ro  
 Web: <http://meo.etc.upt.ro/>



## AFFORDABLE AUTONOMOUS UNDERWATER VEHICLE (AUV) FOR SEARCH, INSPECTION AND MAINTENANCE OPERATIONS IN TURBID UNDERWATER

### Goal of the project:

Developing an underwater enhancing technique that can work in real-time for affordable Autonomous Underwater Vehicle (AUV)

### Short description of the project:

Autonomous Underwater Vehicles (AUVs) are devices able to follow a predefined route or is computing and adjusting the route as a result of sensor measurements. They were developed and used successfully on various applications; such as oceanographic surveys, bathymetric measurements, underwater maintenance and inspections activities (e.g. of the hydroelectric dams, bridges, sea wind turbines and oil sea platforms structure). Taking advantage of the latest advances in hardware and software, an ever-increasing number of underwater studies rely on AUVs that offer increased operational range and reduce potential hazards compared to classical methods involving divers or manned submersibles.

However, the existing AUVs performances are currently very limited due to the poor underwater visibility. In general the existing restoration techniques are too computationally expensive for AUVs. This project proposes a radically novel paradigm that provides the basis for more direct, interactive and efficient underwater studies, while reducing the associated costs. The technologies developed in the context of this project will allow the scientists to directly study, in an immersive way and in real-time, the environment surveyed by the AUVs, while allowing remotely interacting with the vehicle in a natural and intuitive manner.

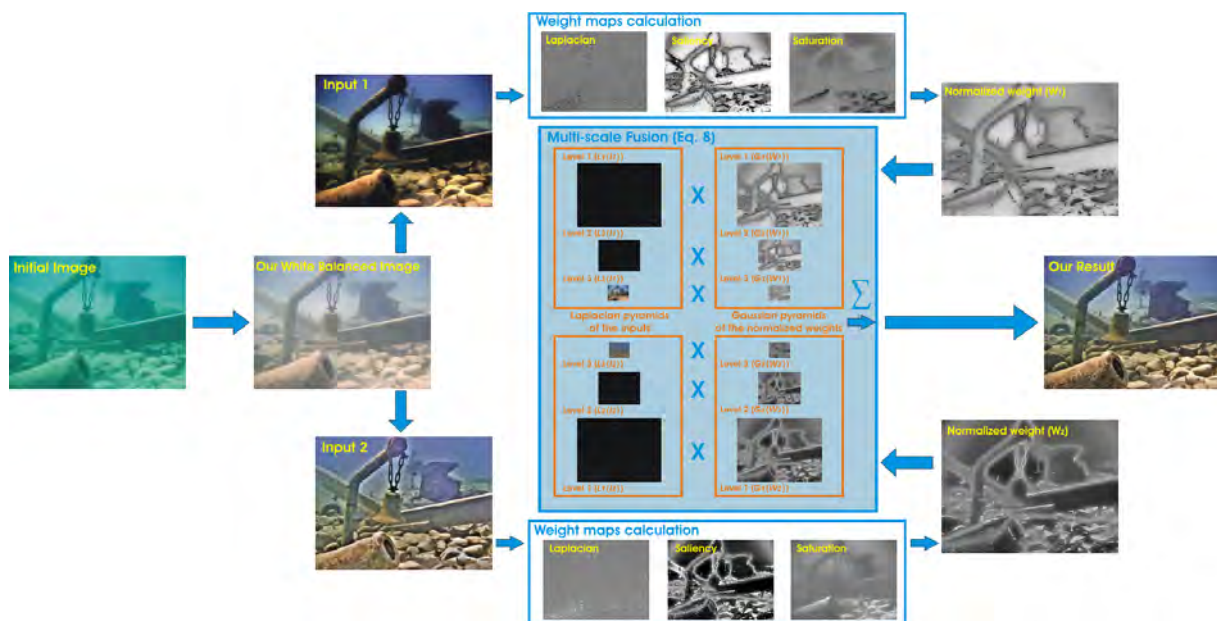

Figure 1: Overview of the proposed method.

Project implemented by

University Politehnica Timisoara, Romania

Implementation period:

January 2017- June 2018

## Main activities:

The main activities of the project:

- identification of specific requirements of underwater imaging technique to be implemented on a specific hardware platform;
- design of an exploration path for specific functionalities;
- designing and recording of specific underwater image scenarios;
- implementation of the underwater imaging technique;
- optimize and integrate the underwater enhancing technique;
- publish the results;

## Results:

- Developing an effective underwater enhancing technique
- 2 WOS/ISI papers and 1 BDI paper
- 1 ISI journal (IEEE Transactions on Image Processing, Q1, impact factor 4.8)

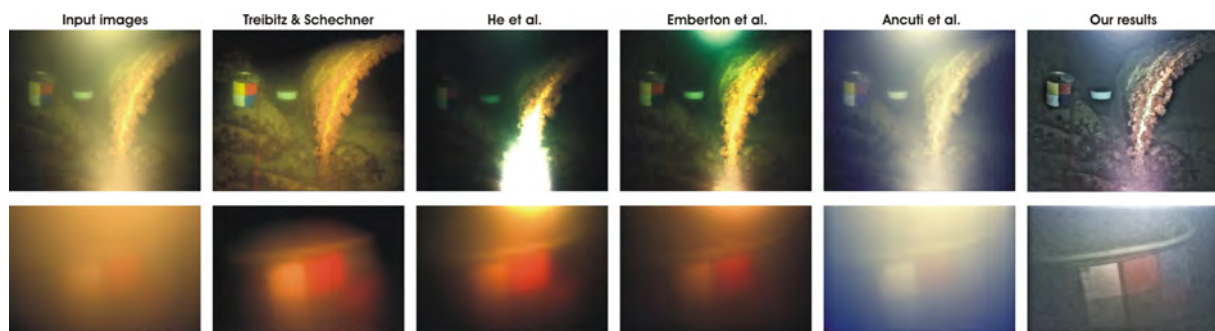

Figure 2: Underwater dehazing of extreme scenes characterized by non-uniform illumination conditions. Our method performs better than earlier approaches of Treibitz and Schechner, He et al., Emberton et al. and Ancuti et al

## Applicability and transferability of the results:

The outcome of this project may be applied in the field of underwater imaging and in the AUV's industry.

## Financed through/by

Executive Agency for Higher Education, Research, Development and Innovation Funding (UEFISCDI), Bucharest, Romania

## Research Center

Research Center of Intelligent Systems

## Research team

Dr. Ing. Cosmin Ancuti  
Conf. Dr. Ing. Horia Balta  
Dr. Ing. Codruta Ancuti  
Drd. Arpad Kis

## Contact information (Ex)

Dr. habil. Eng. Cosmin Ancuti  
Lecturer,  
Universitatea Politehnica Timisoara,  
Faculty of Electronics and Telecommunications Engineering,  
room B312  
2 Vasile Parvan Blvd., 300223, Timisoara, Romania  
Email: cosmin.ancuti@upt.ro  
Tel: (+40)-0256-403363  
Fax: (+40)-0256-403295



## TRANSFER OF KNOWLEDGE FOR FATIGUE STRENGTH EVALUATION OF STEERING WHEELS SKELETON

### Goal of the project

- Interconnection of the expertise of the project team from University Politehnica Timisoara with the quality assurance requirements of TRW Company for the steering wheels.
- Transfer of knowledge regarding the static and dynamic characterization of Magnesium alloys.
- Intensification of the cooperation between University Politehnica Timisoara and TRW Company for understanding of mechanical behavior and for the implementation of a methodology to assess the durability of steering wheel skeletons.

### Short description of the project

The project propose a transfer of knowledge from the experts from University Politehnica Timisoara in order to implement the methodology to determine the fatigue strength of steering wheel skeleton.

### Project implemented by:

Universitatea Politehnica Timisoara and TRW AUTOMOTIVE SAFETY SYSTEMS SRL (Economic partner)

### Implementation period

30/09/2016-29/09/2018

### Main activities

- Interconnection of the expertise of the project team from University Politehnica Timisoara with the quality assurance requirements of TRW Company for the steering wheels.
- Mechanical characterization and determination of static and dynamic properties of Magnesium alloys used for steering wheels.
- Elaboration of material models for Magnesium alloy AM50. Numerical estimation of durability of steering wheel skeletons.
- Practical training of master students from University Politehnica Timisoara on modern equipment of TRW company.

### Results

The TRW company will implement a methodology to evaluate the fatigue strength for the steering wheels skeleton made of Magnesium alloys and will be able to perform in-house tests at the Timisoara branch.

After the project implementation the TRW company will receive a methodology to assess the static and dynamic characteristics of Magnesium alloys. Also, will be developed the methodology to assess the fatigue strength of steering wheels skeletons. Very important results are represented by fatigue curves for Magnesium alloy, which could be useful in the design stage to perform numerical durability studies.

Participation at two international conferences ARTENS - Sibiu 2016 and ICSID - Dubrovnik 2016. Publication of the paper FATIGUE ANALYSIS OF MAGNESIUM ALLOYS COMPONENTS FOR CAR INDUSTRY, Authors L. Marsavina, L. Rusu, D. Serban, R. Negru, A. Cernescu, ACTA UIVERSITATIS CIBINIENSIS – TECHNICAL SERIES Vol. LXIX 2017, p. 47-51

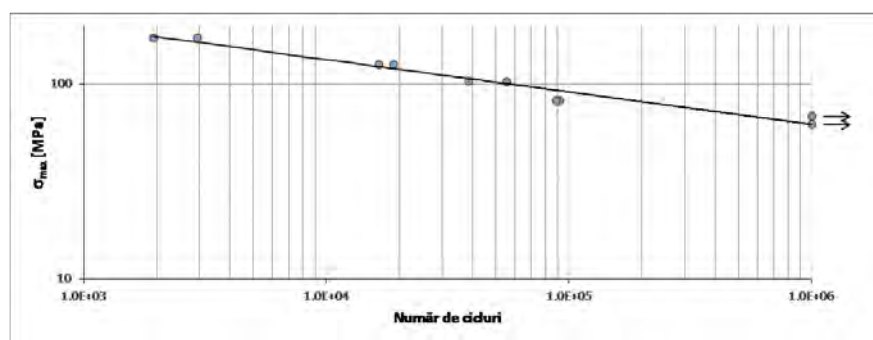

Fatigue curve on tensile loading for AM50 Magnesium alloy

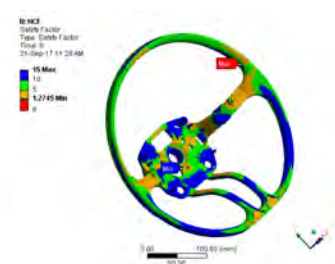

Safety factor under fatigue loading

## Applicability and transferability of the results:

The TRW company will implement a methodology to evaluate the fatigue strength for the steering wheels skeleton made of Magnesium alloys and will be able to perform in-house tests at the Timisoara branch. After the project implementation the TRW company will receive a methodology to assess the static and dynamic characteristics of Magnesium alloys. Also, will be developed the methodology to assess the fatigue strength of steering wheels skeletons. Very important results are represented by fatigue curves for Magnesium alloy, which could be useful in the design stage to perform numerical durability studies.

## Financed through/by

Bridge Grant PN-III-P2-2.1-BG-2016-0060, Contract 89BG/2016 89 by Romanian Ministry of Research through UEFISCDI

## Research Center

ICER

## Research team

Prof. Dr. Eng. Liviu Marsavina – Project Manager  
Dr. Eng. Radu Negru – Researcher,  
Dr. Eng. Emanoil Linul – Researcher,  
Dr. Eng. Lucian Rusu – Researcher,  
Dr. Eng. Dan A. Serban – Researcher,  
Dr. Eng. Sergiu Gălăţanu – Researcher,  
Dr. Eng. Liviu Pîrvulescu – Researcher,  
Eng. Alecsandru Falk – PhD student,  
Mat. Raluca Pepelan – PhD student,  
Eng. Tamasz Krausz – Master student

## Contact information (Ex)

Prof. Liviu MARSAVINA, PhD  
Faculty Mechanical Engineering  
Department Mechanics and Strength of Materials  
Address: Blvd. M. Viteazu, No. 1, 300222 Timisoara  
Phone: (+40) 256 403 577, Mobile:(+40) 726 397 635  
E-mail: liviu.marsavina@upt.ro  
Web: <http://dev.mioritix-media.ro/2423/>

## TRANSFER OF KNOWLEDGE FOR DASHBOARD AND HEAD-UP DISPLAY OPTIMIZATION THROUGH TESTING AND MODELLING OF ADVANCED MATERIALS

### Goal of the project

The goal of the project is the determination of strain rate and temperature variation in mechanical properties of several advanced materials used in vehicle instrument clusters and Head-Up displays. With the gathered experimental data, non-linear material models are to be developed for the use in finite element analysis of various components during the product design stage.

### Short description of the project

This project deals with the mechanical characterization and numerical simulations of advanced materials used in the automotive industry

### Project implemented by:

This project is implemented by Universitatea Politehnica Timișoara with the support of Continental Automotive Romania.

### Implementation period

01/10/2016 – 31/03/2018

### Main activities

01. Determination of the mechanical and thermal properties of the investigated materials
  - Static tests (determination of the influence of strain rate and temperature)
  - Fatigue tests
  - DMA tests
02. Development and evaluation of constitutive models used in simulations
  - Development of constitutive models based on the gathered experimental data
  - Evaluation of the developed material models through experiment replication
03. Implementation of the constitutive models in product simulations
  - Analysis of simulation results and comparison with experimental data
  - Identification of optimal models from an accuracy and simulation time standpoint
04. Development of procedures for facilitating the introduction of new materials
  - Establishment of a test benchmarks
  - Proposal of easy-to-calibrate material models for simulating new materials

### Results

In this project, the experimental procedures determined the mechanical properties of 5 materials. The strain rate influence on the tensile and flexural properties was investigated in the range of 2 – 200 mm/min test speed, showing a noticeable influence on the strength and stiffness of the materials. The materials were also tested in a temperature range of -35 °C to 80 °C, showing significant variation in strength, stiffness and also in behavior (Figure 1).

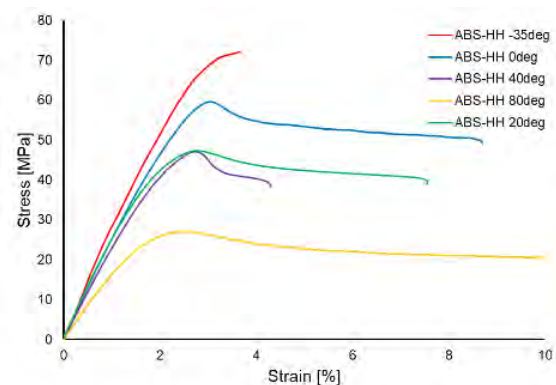

Other experimental procedures included DMA tests and the determination of the Poisson ratio.

The gathered experimental data was used to calibrate elastic-plastic material models for finite element analysis simulations. Temperature and strain-rate dependency was integrated in the models, the material evaluation showing good agreement with the experimental results.

## Applicability and transferability of the results:

The aim of the Bridge Grant was to directly aid companies through the transfer of knowledge, all results being delivered to the project partner:

- The experimental results were supplied to Continental Automotive Romania, the data being used in the material selection process in product design.
- The proposed material models will be used by Continental Automotive Romania in numerical analyses of newly designed components.

## Financed through/by

UEFISCDI

## Research Center

Ștefan Nădășan Laboratory

## Research team

Dr. Eng. Dan-Andrei ȘERBAN – Project manager

Prof. Dr. Eng. Liviu MARȘAVINA

Dr. Eng. Radu NEGRU

Dr. Eng. Emanoil LINUL

Dr. Eng. Corina ȘOȘDEAN

Dr. Camelia ARIEȘANU

Eng. Gabriel PRAȚA

Eng. Adelin ENESCU

Eng. Cristian CODRESCU

## Contact information (Ex)

Dan-Andrei ȘERBAN, PhD

Mechanical Faculty/

Department of Mechanics and Strength of Materials,

Address: Mihai Viteazu Str., No. 1 Postal Code 300222, Timisoara

Phone: (+40) 256 403 741

E-mail: dan.serban@upt.ro

## CENTRALIZING AND OPTIMIZING SCADA IN THE WATER SECTOR (CASCADA)

### Goal of the project

The knowledge transfer to Aquatim through software and hardware modules and strategies for centralizing and optimizing SCADA for the water sector.

### Short description of the project

The general purpose of CASCADA is the knowledge transfer to the economic operator through software and hardware modules and strategies to solve stated problems in centralizing and optimizing SCADA for the water sector. The project proposes the ICOM module (Interface, Conversion, Optimization, Modularity) as instrument in solving both interfacing and protocol conversion problems and the development of non-invasive optimization modules of controlling groups of objectives already in function in the water sector. Also, in order to improve effectiveness, the project addresses the IGSS SCADA implementation strategy in Aquatim control center and the existing communication system. CASCADA wants to train Aquatim in SCADA/automation/communications new technologies and to practically apply the concepts in a SCADA analysis of three existing objectives of the operator.

### Project implemented by

University Politehnica Timisoara

### Implementation period

30.09.2016-30.09.2018

### Main activities:

The activities are foreseen to implement the following three objectives:

- 1) Realizing and testing the ICOM module;
- 2) Optimizing the IGSS control center;
- 3) Direct knowledge transfer in new technologies.

### Results

CASCADA, through the ICOM module will solve the SCADA integrability problems of the economic operator, respectively will provide an instrument, independent of local equipment and SCADA solutions, to answer integrability and functioning optimization issues for groups of interdependent objects as technological flow but independent regarding their implementations. Therefore, due to SCADA correlations of groups of objects (integrations on higher SCADA levels and creating control algorithms for group of objects), the economic operator's systems will be more stable and efficient, respectively the impact of the incidents will be reduced. Optimizing the IGSS control center will provide the possibility to

maximally use the resources available through licensing, an increased communication speed through systematizing the internal Aquatim network, respectively an adequate web based access conferred by the WebNavIGSS module.

CASCADA will impact also the quality of the future investments of the economic operator through opening perspectives to new technologies and optimal solutions, with increased efficiency and reduced costs.

The implemented activities will strengthen the entrepreneurial abilities of researchers and the connection between the academic environment and the industry requirements.

### Applicability and transferability of the results

As a bridge grant, the project is strongly industry oriented, with significant practical value and focused on the knowledge transfer to an economic operator.

### Financed through/by

UEFISCDI

### Research Centre

ICER – Renewable energy research institute

### Research team

Adrian Ștefan KORODI  
Ioan SILEA  
Octavian ȘTEFAN  
Ruben Dan CRIȘAN  
Teodor HUPLE  
Alexandra-Ionela BASSO-ȚIDREA  
Mihaiță-Alin RADU  
Mihaela Marcella CRIȘAN-VIDA  
Oana-Sorina CHIRILA

### Contact information

S.L. Adrian Ștefan KORODI, PhD  
Faculty of Automation and Computers,  
Department of Automation and Applied Informatics  
Address: Str. V. Parvan, No. 2, 300223, Timișoara  
E-mail: adrian.korodi@upt.ro

## MESSAGE PASSING ITERATIVE DECODERS BASED ON IMPRECISE ARITHMETIC FOR MULTI-OBJECTIVE POWER-AREA-DELAY OPTIMIZATION

### Goal of the project

The DIAMOND project proposes to exploit the robustness of modern decoders to arithmetic inaccuracies, for improving their latency and power consumption. The project focuses on Low-Density Parity-Check (LDPC) codes widely used in modern communication systems, and targets the design of message-passing iterative decoders using imprecise arithmetic units. We aim at harnessing the inaccuracies produced by imprecise computational units, while benefiting of their significant reductions in area, latency and power consumption.

### Short description of the project

The project investigates the possibility of optimizing LDPC decoding architectures by employing imprecise and approximate techniques at different levels: message representation, processing unit and architecture.

### Project implemented by

- Universitatea Politehnica Timisoara (UPT) – Romanian partner
- CEA-LETI, Grenoble – French coordinator partner
- ETIS Laboratory – French partner

### Implementation period

March 2014 – March 2017

### Main activities:

DIAMOND project have analyzed the impact of the introducing impreciseness and approximations in LDPC decoding architecture on the decoding performance, cost and throughput. The main activities involved:

1. Development of LDPC decoding techniques using imprecise message representation
2. Analysis and development of imprecise processing units
3. Development of imprecise stopping criteria for layered decoding
4. Development of proof-of-concept decoders using the imprecise techniques at different levels.

### Results

The main results of the DIAMOND project include:

1. Imprecise message representation techniques – these include the development of the modified offset min-sum (MOMS) LDPC decoding, as well as the non-subjective finite alphabet iterative decoding of LDPC codes.
2. Imprecise processing units – the main developments have consisted in a novel check node unit using one-hot representation of messages, and a novel version of self-correcting min-sum (SCMS), that allows the implementation of this SCMS based LDPC decoder with a similar cost as the Min-Sum based ones.
3. Imprecise early termination criteria for layered LDPC decoders

In order to provide a wide range of proof-of-concept decoding architectures, for which a wide range of architecture and code parameters can be analyzed, an integrated environment for the architecture generation, verification and implementation – TEDI – has been developed.

### Applicability and transferability of the results

The DIAMOND project aims at optimizing LDPC decoding architectures used for forward error correction in both wireless communications and data storage. Several steps for economic and industrial results dissemination have been undertaken. On one hand, a simplified version of the LDPC decoding architecture generator has been made publicly available on the webpage [dbyalick.cs.upt.ro](http://dbyalick.cs.upt.ro). On the other hand, the proposed stopping criteria for layered LDPC decoding architectures has been considered for a joint patent application between the project partners.

### Financed through/by

UEFISCDI – Romanian funding agency  
ANR – French funding agency  
Romanian project number: PN-II-ID-JRP-RO-FR-2012-0109

### Research Centre

Research Centre in Computing and Information Technology – CCCTI

### Research team

Dr. Oana Boncalo – Principal Investigator  
Dr. Petru Mihancea  
Ioana Mot  
Gyorgy Kolumban Antal  
Petra Csereoka

### Contact information

Oana Boncalo, PhD  
Department of Computer and Information Technology  
Address: Vasile Parvan Blvd., Nr. 2, 300223, Timisoara  
Phone: (+40) 256 403264  
E-mail: [oana.boncalo@cs.upt.ro](mailto:oana.boncalo@cs.upt.ro)  
Web: <http://staff.cs.upt.ro/~boncalo/diamond/contact.html>

## DIVIDEND - DISTRIBUTED HETEROGENEOUS VERTICALLY INTEGRATED ENERGY EFFICIENT DATA CENTRES

### Goal of the project

DIVIDEND aims to optimize heterogeneous data centers, combining CPUs, GPUs, and task-specific accelerators, as a unified entity to the application developer and let the runtime optimize the utilization of the system resources during task execution. DIVIDEND embraces heterogeneity to dramatically lower the energy per task through extensive hardware specialization while maintaining the ease of programmability of a homogeneous architecture.

### Short description of the project

DIVIDEND provides cross layer energy monitoring and management in data centers that use heterogeneous CPU, GPU and FPGA based processing. We aim to provide energy optimization using a vertical based integration from different abstraction layers: hardware, operating system, compiler and application.

### Project implemented by

- University of Edinburgh – Coordinator
- University of Lancaster
- Queens University of Belfast
- Ecole Polytechnique Federale de Lausanne
- Universitatea Politehnica Timisoara
- INRIA Paris,
- Advanced Micro Devices, Paris

### Implementation period

May 2015 – May 2017

### Main activities:

The main activities performed in UPT are related to the development and integration of energy monitoring of dedicated FPGA accelerators into the Distributed Heterogeneous System Architecture (DHSA) concept. The UPT research represents the first approach to use the FPGA accelerators in hybrid architecture with full access to the system shared memory, as well as complete queuing support for DHSA. We aim at providing efficient acceleration for irregular parallel application using the proposed approach.

### Results

The DIVIDEND project has provided a complete integration of FPGA based application accelerators into the DHSA systems, by offering the required hardware, as well as driver and operation system level support. Furthermore, energy accounting for dedicated FPGA hardware accelerators for distributed applications is offered. Therefore, an energy aware FPGA acceleration in distributed HSA based heterogeneous CPU-GPU-FPGA systems has been developed.

### Applicability and transferability of the results

The DIVIDEND project developed the first approach that provides an energy cost for an application that has been executed in the distributed data center, composed of a heterogeneous computation platform consisting of CPUs, GPUs, or FPGAs. Therefore, for each user which runs applications on a data-center, a cost for the execution of each task can be offered. Therefore, the DIVIDEND project offers an energy aware application execution framework on distributed data-centers.

### Financed through/by

CHIST-ERA NR 5/2015

### Research Centre

Research Centre in Computing and Information Technology – CCCTI

### Research team

Dr. Alexandru Amaricai – Principal Investigator  
Prof. Marius Marcu  
Dr. Sebastian Fuicu  
Dr. Cosmin Cernazan  
Dr. Sergiu Nimara  
Gyorgy Kolumban Antal

### Contact information

Alexandru Amaricai, PhD  
Department of Computer and Information Technology  
Address: Vasile Parvan Blvd., Nr. 2, 300223, Timisoara  
Phone: (+40) 256 403272  
E-mail: alexandru.amaricai@cs.upt.ro



## ECO-EFFICIENT RECOVERY OF WASTES FROM HOT DIP GALVANIZING PROCESS AS ANIONIC CLAYS APPLICABLE FOR REMOVAL OF UNDESIRABLE COMPOUNDS FROM WATER

### Goal of the project

The main objective of the project is the synthesis of anionic clays (layered double hydroxides) from wastes of hot dip galvanizing process (zinc ash and sludge from wastewater treatment) and the utilization of these materials in removal processes (adsorption or photocatalysis) of undesirable compounds from water (i.e. phenols, dyes, chromate). Another objective is to gain significant research experience for the project team.

### Short description of the project

By treatment of industrial wastes some layered double hydroxides (LDH) will be prepared. The correlation between the chemical characteristics of precursors of LDH obtained from wastes and the performances of LDHs in removal processes of undesirable compounds from water will be clarified.

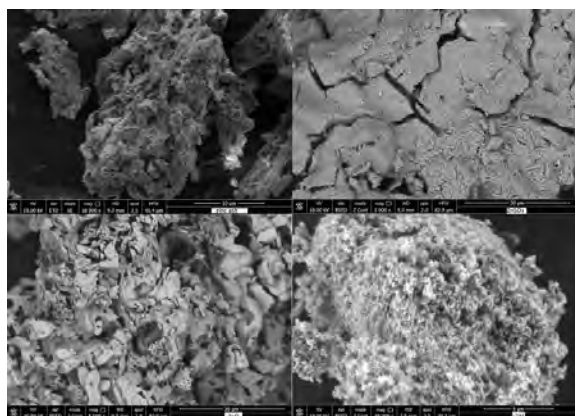

Figure 1. SEM images of zinc ash and product obtained after zinc ash treatment ( $ZnSO_4$ ,  $ZnO$  and LDH)

### Project implemented by

Faculty of Industrial Chemistry and Environmental Engineering

### Implementation period

01.10.2015 – 30.09.2017

### Main activities:

1. The influence of the working parameters of wastes treatment process on the chemical characteristic of the obtained metal solutions;
2. The influence of the chemical characteristics of solution precursors on the morphological and surface properties of the synthesized LDH;
3. The performances of the synthesized LDH in the sorption and photocatalytic processes for removal of undesirable compounds from water.

### Results

1. Method for valuable metal recovery from wastes of hot dip galvanizing process.
2. New method for anionic clay synthesis from metal ions recovered from wastes of hot dip galvanizing process.
3. Method for removal of undesirable compounds from water by anionic clays synthesized from wastes of a "dirty industry".

### Applicability and transferability of the results

By applying this approach, the wastes of a "dirty industry" (hot dip galvanizing process) are treated and a valuable product is added, keeping in mind that the anionic clays have multiple utilizations at industrial scale as plastic additives, as flame retardant and as anions scavengers. The project has an interdisciplinary character presenting an integrated concept of industrial wastes treatment and waters depollution.

### Financed through/by

Romanian National Authority for Scientific Research and Innovation, CNCS - UEFISCDI

### Research Centre

Research Institute for Renewable Energy

### Research team

Assist.Prof. Laura Coheci, PhD  
Lecturer Lavinia Lupa, PhD  
Lecturer Marius Gheju, PhD  
Eng. Delia Andrada Duca, PhD student  
Eng. Alin Golban, PhD student

### Contact information

Assist.Prof. Laura COCHECI, PhD  
Faculty of Industrial Chemistry and Environmental Engineering/  
Department of Applied Chemistry and Engineering of Inorganic  
Compounds and Environment  
Address: Vasile Parvan Bl., No. 6, 300223, Timișoara  
Phone: (+40) 256 403069  
E-mail: laura.coheci@upt.ro  
Web: <https://sites.google.com/site/pniirute20140771/>

## SYNERGIC GREEN TECHNOLOGIES FOR TREATMENT OF HEXAVALENT CHROMIUM POLLUTED WATERS

### Goal of the project

The first major objective of this project will be to study the influence of co-presence of sand,  $MnO_2$  and sand coated with manganese oxides on Cr(VI) efficiency of removal with metallic iron. The second major objective of this project is to study the immobilization of exhausted reactive mixtures containing Fe, Cr, sand and  $MnO_2$  in vitreous matrices. The Cr, Fe and Mn immobilization in the glass matrix will be analyzed in order to convert the resulting glasses into marketable glazes or bulk glass products.

### Short description of the project

The proposed theme is integrated in the thematic area of water and wastewater treatment, with the aim of water reuse, waste recovery and protection of environment quality.

### Project implemented by

University Politehnica Timisoara

### Implementation period

01.10.2015–30.09.2017

### Main activities:

1. Batch treatability experiments. Will be performed using a Berzelius flask containing Cr(VI) solution. Determined amounts of reactive materials are added to the solution and flask contents will be mixed continuously. Aliquots will be periodically extracted and analyzed.
2. Continuous long term column treatability experiments. Will be performed using an experimental setup comprising: columns with reactive material filling; peristaltic pump used to pass the Cr(VI) aqueous solution through the column; storage tank for the Cr(VI) solution. The Cr(VI) solution will be passed through the column packed with reactive material filling. Column effluent samples will be withdrawn at regular time intervals and analyzed.
3. Experiments regarding the synthesis of glasses from wastes. The exhausted reactive materials will be mixed with glass powders and borax and then melted in an electric furnace. In order to obtain bulk glass products the melt is press-quenched between two stainless steel blocks and annealed to remove stress. The granular frits are obtained after pouring the melts in cold water. The glaze slurry is prepared using the obtained frits (95%) and kaolin (5%) as suspension material. The terracotta plates glazed by immersion are dried and then fired at 980°C for 30 min. For the porous glass synthesis a foaming agent (SiC) was added together with the waste glass powder and the exhausted reactive mixtures. The raw materials are mixed together and then uniaxial pressed into cylindrical samples. The samples, dried at 80°C for 12 hours are treated at 900°C for 10 minutes.

### Results

The assessment of sand co-presence on Cr(VI) removal with metallic iron.

The assessment of  $MnO_2$  co-presence on Cr(VI) removal with metallic iron.

The assessment of  $MnO_2$  and sand mixtures co-presence on Cr(VI) removal with metallic iron

The immobilization of exhausted reactive mixtures containing sand, Fe and Cr in vitreous matrices.

### Applicability and transferability of the results

Treatment of waters polluted with Cr(VI).

Conversion of wastes into marketable glazes or bulk glass products

### Financed through/by

Project PNII-RU-TE-2014-4-0508 No. 129/1/10/2015, Synergic green technologies for treatment of hexavalent chromium polluted waters. Total funding: 550000 RON

### Research Centre

ICER

### Research team

Gheju Marius Traian – Project manager

Balcu Ionel – Postdoctoral researcher

Moșoarcă Giannin Emanuel – Postdoctoral researcher

Vancea Cosmin Nicolae – Postdoctoral researcher

Bălășoiu-Flueraș Adriana Maria – PhD student

Enache Andreea – PhD student

### Contact information

Lecturer Marius GHEJU, PhD

Faculty of Industrial Chemistry and Environmental Engineering/  
Department CAICAM

Address: Bd. Vasile Pârvan, nr. 6, 300223 Timișoara, România

Phone: (+40) 256 404185

E-mail: marius.gheju@upt.ro

## EXPERIMENTAL MODEL FOR AN AUTOMATIC CAPACITIVE COMPENSATOR DESIGNED FOR IMPROVING THE POWER FACTOR AND FOR LOAD BALANCING IN LOW-VOLTAGE ELECTRICITY DISTRIBUTION NETWORKS - CAEREDJT

### Goal of the project

The project is intended to finance industrial research activities, needed to put in practice under the form of an experimental model of research findings of a group of academics from UPT, concerning the network load balancing electric phase through cross unbalanced capacitive compensation. In electrical networks, inductive load variation implies variation of the capacitive compensation, thus the need for building an unbalanced capacitive automatic compensator, to track the load variation.

### Short description of the project

The automatically unbalanced capacitive compensator proposed by this project is an innovative product, so achieving a functional experimental model involves overcoming a number of scientific and technical challenges, the most important being: control and single-phase switching of the capacitor batteries steps, the construction algorithm and implementation of a programming language for PLC process control, process optimization for automatic compensation.

### Project implemented by

- Politehnica University of Timisoara – Lead partner
- S.C. ICPE S.A. Bucharest – Project partner

### Implementation period

01.07.2014 - 30.09.2017

### Main activities

1. Conducting studies and analysis on the alternative constructive solutions and developing the technical documentation for the construction of the experimental model.
2. Manufacturing of the experimental model and the analysis, control and monitoring systems.
3. Testing the model and proving its functionality and its utility
4. Dissemination of results and protect the intellectual property rights.

### Financed through/by

Executive Unit for Financing Higher Education, Research, Development and Innovation - UEFISCDI

### Applicability and transferability of the results

The results of the project are useful for unbalanced electrical loads supplied at low voltage level, and also for the Distribution system operator (DSO).

### Results

- The main outcome of the project will be a functional experimental model and its documentation of implementation for a capacitive compensator designed to improve power factor and load balancing in networks of low voltage power distribution.
- It will underpin the design and construction in a later stage, of a prototype of a capacitive automatically balance high power compensator (tens of kVA) for increasing network performance of low-voltage power distribution and utilization facilities connected to it, by reducing reactive power flow and load balancing.
- The results of the research will be disseminated in scientific papers in professional journals or communication conferences.
- New technical solutions brought by this automatic capacitive compensator, as regard to the structure, order, sizing, automatic control algorithm, will be the subject of intellectual property protection activities.

### Research Centre

Analysis and Optimization of the Electrical Power Systems Regimes

### Research team

Assoc.Prof. Adrian Pană, PhD  
Prof. Radu - Emil Precup, PhD  
Prof. Ștefan Preitl, PhD  
As. Florin Molnar-Matei, PhD  
As. Alexandru Băloi, PhD  
Lecturer Ilie Mihai Tăcucean, PhD  
Lecturer Mircea-Bogdan Rădac, PhD  
As.Claudia-Adina Bojan-Dragoș, PhD  
Alexandra Lulia Stînean, PhD  
Eng. Andrei Plettinger

### Contact information

Assoc. Prof. Adrian PANĂ, PhD  
Department of Power Engineering  
Address: Bv. Vasile Pârvan, No. 2, RO300223, Timisoara  
Phone: (+40) 256 403420  
E-mail: adrian.pana@upt.ro  
Web: <https://sites.google.com/site/caeredjt/>

## NOVEL TECHNIQUE TO ENHANCE THE SECURING LEVEL OF SECURITY PAPER USING THE SUPERPARAMAGNETIC FINGERPRINT OF MAGNETIC NANOPARTICLE DISPERSIONS - NANOMAGSECURITY PAPER

### Goal of the project

The continuous diversification of the paper securing techniques is one of the most important ways to erect fences against forgery attempts. The project aims to expand the diversity of high tech means for paper securing. The general objective of the project is to elaborate a new paper securing technique based on the superparamagnetic fingerprint of magnetic nanoparticles made of oxide compounds

### Short description of the project

The objective is to elaborate a new paper securing technique based on the superparamagnetic fingerprint of the magnetic nanoparticles.

### Project implemented by

- Romanian Academy – Timisoara Branch (Project Coordinator)
- SC CEPROHART SA (Partner 1)
- SC ROSEAL SA Odorheiu Secuiesc (Partner 2)
- SC Datronic – NCIP SRL (Partner 3)
- National Institute of R&D for Izotopic and Molecular Technologies Cluj-Napoca (Partner 4)
- Politehnica University of Timisoara (Partner 5).

### Implementation period

July 1, 2014 – September 30, 2017

### Main activities

- elaboration of superparamagnetic paper assortments with
  - low security level, using poly-disperse magnetic nanoparticles
  - high security level, using bi-disperse magnetic nanoparticles
  - white color, using core-shell (core/magnetic, shell/polymer) particles
- elaboration and testing the authentication method by static and dynamic magnetometry

### Results

- methods for synthesis and characterization of oxide magnetic nanocomposites
- methods for elaboration and validation of magnetic loaded papers
- first instance validation of magnetic loaded papers

### Financed through/by

Executive Unit for Financing Higher Education, Research, Development and Innovation (UEFISCDI)

### Applicability and transferability of the results

The new method of securing paper using the superparamagnetic nanoparticles can be transferred to SC Ceprohart SA Braila. The transfer will contribute to:

- diversification of the product made in the national paper industry with simple brown paper secure and secure complex white paper,
- orientation of national industry to obtain a special paper grade with high complexity,
- increase the security level of specialty papers, difficult to fake on the internal market
- reduce the imports of security paper
- increase output and thus sales of security paper from Ceprohart.

### Research centre

Research Centre for Engineering of Systems with Complex Fluids – Laboratory of Rheology and Magnetometry, from Politehnica University of Timisoara.

URL: <http://mh.mec.upt.ro/ccisfc/>

### Research team

Dr. Oana MARINICA  
Dr. Aurel ERCUTA  
Dr. Catalin MARIN  
Techn. Florica BĂLĂNEAN  
Techn. George GIULA

### Contact information

Dr. Vlad SOCOLIUC – Project Director  
Romanian Academy – Timisoara Branch, Center for Fundamental and Advanced Technical Research, Laboratory of Magnetic Fluids  
Bd. Mihai Viteazu No. 24, 300223, Timisoara, Jud. Timis  
Tel./Fax: (+40) 256 403700  
E-mail: [vsocoliuc@gmail.com](mailto:vsocoliuc@gmail.com)

Dr. Oana MARINICA – Project Responsible from Partner 5  
Politehnica University of Timisoara, Research Center for Engineering of Systems with Complex Fluids, Laboratory of Rheology and Magnetometry,  
Bd. Mihai Viteazu No. 1, 300223, Timisoara, Jud. Timis  
Tel./Fax: (+40) 256 403700  
E-mail: [oana.marinica@upt.ro](mailto:oana.marinica@upt.ro); [marinica.oana@gmail.com](mailto:marinica.oana@gmail.com)  
Web: <http://vsocoliuc.wordpress.com/projects/nanomagsecurity-paper/>

## MAGNETIC NANOFUID ROTATING SEAL SYSTEMS FOR HIGH PERIPHERAL SPEEDS - HISPEED NANO MAG SEAL

### Goal of the project

The project technical objective is to achieve at experimental model scale new leakage-free MNF sealing systems for high peripheral speeds (up to  $30 - 70 \text{ m}\cdot\text{s}^{-1}$ ) in the sealing area, designed to equip gas turbo-compressors.

### Short description of the project

The project proposes the development of seals with magnetic nanofluid (MNF), which has significant advantages compared to conventional mechanical seals: hermetic sealing, exceptionally long lasting operation without intervention (5 years), minimal wear (only viscous friction), virtually zero contamination, optimal torque transmission, wide operating range ( $10^{-8}$  mbar - 10 bar), relatively simple and cost efficient execution.

### Project implemented by

- SC ROSEAL SA Odorheiu Secuiesc (Project coordinator)
- Romanian Academy – Timisoara Branch (Partner 1)
- National Institute of R&D for Izotopic and Molecular Technologies Cluj-Napoca, Politehnica University of Timisoara (Partner 2)
- Politehnica University of Timisoara (Partner 3)
- Romanina Research and Development Institute for Gas Turbines – COMOTI Bucharest (Partner 4)

### Implementation period

July 1, 2014 – September 30, 2017

### Main activities:

- laboratory and micropilot scale synthesis of magnetic nanofluids with carboxylic stabilizers and magnetizations between 400-1000 G
- conception, design and implementation of new experimental models of sealing systems with magnetic nanofluid for high peripheral speeds
- testing and performance evaluation of new experimental models sealing systems with magnetic nanofluid, designed for high peripheral speeds

### Results

- methods for synthesis and characterization of high magnetization nanofluids with carboxylic stabilizers
- experimental models for new sealing systems
- experimental models for sealing systems – innovative version with magnetic nanofluids with carboxylic stabilization

### Applicability and transferability of the results

The expected results will facilitate design and low cost industrial scale production of an original sealing system with stable MNF at high temperatures ( $160 - 180 \text{ }^\circ\text{C}$ ), for high peripheral speeds (up to  $30 - 70 \text{ m}\cdot\text{s}^{-1}$ ) in the sealing gap. They have some important advantages compared to conventional mechanical seals: hermetic sealing, high reliability, relatively simple construction, low execution cost. These performances indicate the market towards ROSEAL Co. is heading, namely the gas turbo-compressors in fertilizer and petroleum refining industry.

### Financed through/by

Executive Unit for Financing Higher Education, Research, Development and Innovation (UEFISCDI) .

### Research centre

Research Centre for Engineering of Systems with Complex Fluids – Laboratory of Rheology and Magnetometry, from Politehnica University of Timisoara.

URL: <http://mh.mec.upt.ro/ccisfc/>

### Research team from Politehnica University of Timisoara

Dr. Oana MARINICA  
Dr. Floriana D. STOIAN  
Dr. Nicolae CRANIC  
Dr. Sorin HOLOTESCU  
Techn. Florica BALANEAN  
Techn. George GIULA

### Contact information

Dr. Tunde BORBATH – Project Director  
SC ROSEAL SA  
Str. Nicolae Balcescu No. 5/A, 535600, Odorheiu Secuiesc, Jud. Harghita  
Tel.: (+40) 266 215998; 266 218122; 266 215912; 747 116610  
Fax: (+40) 266 215912  
E-mail: [office@roseal.topnet.ro](mailto:office@roseal.topnet.ro)  
Web: [www.roseal.eu](http://www.roseal.eu); [roseal.topnet.ro](http://roseal.topnet.ro)

Dr. Oana MARINICA – Project Responsible from Partner 3  
Politehnica University of Timisoara, Research Center for Engineering of Systems with Complex Fluids, Laboratory of Rheology and Magnetometry  
Bd. Mihai Viteazu No. 1, 300223, Timisoara, Jud. Timis  
Tel./Fax: (+40) 256 403700  
E-mail: [oana.marinica@upt.ro](mailto:oana.marinica@upt.ro); [marinica.oana@gmail.com](mailto:marinica.oana@gmail.com)  
Web: <http://www.roseal.eu/HiSpeedNanoMagSeal/>

## DEVELOPMENT OF ECO-FRIENDLY COMPOSITE MATERIALS BASED ON GEOPOLYMER MATRIX AND REINFORCED WITH WASTE FIBRES

### Goal of the project

The project is an answer for a specific challenge regarding waste management, recycling and urban mining. The goal of the project is to prepare a broad spectra of advanced and progressive new composite materials based geopolymer matrices and reinforced with natural waste fibres. The application of these new materials will be the construction industry with a high potential of commercial utilization and potential replacement of conventional materials.

### Short description of the project

This project deals with the development of new composite materials for construction industry, based on waste products.

### Project implemented by:

Project coordinator: Cracow University of Technology.

Partners: Nigde University Turkey, Pontificia Universidad Católica del Peru, Riga Technical University Latvia, Babeş-Bolyai University, Catholic University of Uruguay Damas Antonio Larrañaga, Politehnica University of Timișoara.

### Implementation period

02/01/2017 – 31/12/2019

### Main activities

- WP1. The selection of waste materials for hydrothermal alkalization and therefore to be turned into new materials based on geopolymer matrix for construction applications
- WP2. The selection of waste materials (natural fibres) as a fillers and therefore turned into new composites for construction application
- WP3. Optimization of properties using computer methods for the new materials and structural elements
- WP4. The research into the application of new materials – comparison of the functional properties of the materials
- WP5. Analysis of practical applications of new materials for construction application and testing prototype components in laboratory as well as validated it in relevant environment

### Results

The year 2017 had deadlines for the first two Work Packages. WP1, coordinated by Nigde University, dealt with the identification of waste materials for the composite material matrices. Each participating partner performed a survey of possible waste material candidates available in their region (recycled clay bricks and volcanic ash in Peru, fly ash in Turkey, Argentina and Romania, paper mill sludge and rice husk ash in Uruguay and granulated rubber from waste tyres in Poland).

WP2, coordinated by Babeş-Bolyai University, dealt with the identification of waste natural fibres as reinforcements for the composites. As with WP1, each participating partner proposed waste materials available in their region (mostly hemp and flax fibres).

### Applicability and transferability of the results:

The new composite materials that will be developed in this project will be tested and their properties compared with conventional construction materials. If the mechanical and thermal behaviour is comparable between the two categories, the newly developed materials will be proposed for replacing traditional materials in each specific region where the waste products are available.

### Financed through/by

Horizon 2020 - ERA Net Latin America and Caribbean Countries/UEFISCDI

### Research Center

Ștefan Nădășan Laboratory

### Research team

Dr. Eng. Dan-Andrei ȘERBAN – Project manager  
Prof. Dr. Eng. Liviu MARȘAVINA  
Dr. Eng. Radu NEGRU  
Dr. Eng. Emanoil LINUL

### Contact information

Dan-Andrei ȘERBAN, PhD  
Mechanical Faculty/  
Department of Mechanics and Strength of Materials,  
Address: Mihai Viteazu Str., No. 1 Postal Code 300222, Timisoara  
Phone: (+40) 256 403 741  
E-mail: dan.serban@upt.ro





# Research and Development Projects for Young Researchers



## INTERNAL COMPETITION OF POLITEHNICA UNIVERSITY OF TIMISOARA RESEARCH AND DEVELOPMENT PROJECTS FOR YOUNG RESEARCHERS PCD-TC-2017

Domain - Computers and Information Technology

**POPA Călin-Adrian**

Project title - Complex-Valued Deep Neural Networks

Abstract - Three types of complex-valued deep neural networks will be proposed: convolutional networks, deep belief networks, and long short term memory networks, which will be applied for real-valued and complex-valued image recognition and time series prediction.

Domain - Automation and Applied Informatics

**BOJAN-DRAGOS Claudia-Adina**

Project title - Practical applications of tensor product model transformation-based adaptive control

Abstract - The proposed control techniques combine the advantages of both paradigms involved in the design: simplicity and wide applicability.

Domain - Chemical Engineering, Environmental Engineering, Food Engineering

**CIOPEC Mihaela Elvira**

Project title - New materials chemically modified used for arsenic adsorption from water

Abstract - In full accordance with the principles of sustainable development, the project present an integrated concept of arsenic removal from water using new materials chemically modified by doping with crown ethers and iron ions.

Domain - Electronics, Telecommunications, Nanotechnologies

**POP-CALIMANU Ioana-Monica**

Project title - Multiphase converters for solar energy conversion and battery charging in electric vehicles

Abstract - Two systems for energy conversion are proposed: a solar energy conversion system and a battery-charging system in electric vehicles, both based on two new dc-dc multiphase converter families.

Domain - Electrical Engineering, Powers Systems Engineering

**SIMO Attila**

Project title - LoRa - intelligent infrastructure for communications and decision support in power systems

Abstract - The goal is to create a LoRa pilot infrastructure and to develop performant algorithms for: forecasting electricity consumption, forecasting generated power (photovoltaic) and consumption pricing.

Domain - Civil Engineering and Equipments, Cadaster and Geodesy

**TESILA Clara Beatrice**

Project Title - Optimizing risk reduction strategies for geomorphological hazards by 3D modeling

Abstract - Natural hazards, especially landslides, are complex phenomena both regarding their generating causes and also the effects they produce; thus representing a risk factor to be determined and quantified. 3D modeling of geospatial data characteristic to landslides acquired using terrestrial laser scanning technology is useful for monitoring and determining the risk potential of certain areas as well as for managing the destructive effects of geomorphologic hazards on the environment and to optimize their forecasting and post-factum approaches. Nowadays, about 80% of national or local decisions in different areas of activity, such as demography, territorial planning, hazards, infrastructure etc. involves geospatial or georeferenced data. The geodetic engineer participates to the acquisition, manipulation, visualization and analysis of geospatial data characteristic of hazards in order to adopt the most appropriate methods of protecting and preserving the environment in order to adapt to climate change. The project aims to optimize risk reduction strategies for geomorphological hazards by their 3D modeling in the context of Romania's susceptibility and poor management of local authorities who are insufficiently prepared to manage such situations.

Domain - Mechanical Equipment (Mechanical Engineering, Motor Vehicle Engineering, Transportation Engineering)

**STOICA Virgil**

Project Title - Reducing Fuel Consumption of an ICE by recovering lost energy

Abstract - We propose the construction of an experimental test bench with an internal combustion engine for testing, dissipated thermal energy recovery solutions, and reintroduction into the engine cycle.

Domain - Mechanical Equipments (Mechanical Engineering, Automotive Engineering, Transportation Engineering)

**LINUL Emanoil**

Project Title - Mechanical characterization of advanced composite structures with aluminum foam core

Abstract - The proposed project is part of a research direction of innovative materials dealing with the development, mechanical characterization and structural integrity assessment of new advanced composite structures. The obtained composite structures presents exceptional mechanical properties, specialized for applications in the transport field and generally applications requiring lightweight rigid structures. The ultimate goal of these materials is to reduce the weight of the products and to increase the exploitation safety.

Domain - Materials Engineering, Industrial Engineering

**CODREAN Cosmin**

Project Title - Obtaining and characterization of bulk amorphous steels

Abstract - In this project we aim to obtain and characterize bulk amorphous steels from the Fe-Cr- (Mo, Mn) - (Y, Ga) -C- (B, Si, P) family by copper mold casting and using ferro-alloys as raw materials.

Domain - Mechatronic and Robotic

**ZABAVA Eugen Sever**

Project Title - Innovative electronic devices for configuring and reusing packagings.

Abstract - The basic idea of this project is to create and develop a mechatronic device to reconfigure a packaging of conventional materials that, until its recycling, can be reused for another purpose.

Domain - Mathematics, Physics

**LAZUREANU Cristian-Virgil**

Project title - The study of Hamilton-Poisson systems and their integrable deformations using the energy-Casimir mapping

Abstract - We study the connections between the dynamics of Hamilton-Poisson systems and the corresponding energy-Casimir mapping. We consider some classes of integrable systems and integrable deformations of known dynamical systems.

Domain - Economic Sciences and Business Administration

**TAUCEAN Ilie Mihai**

Project Title - Research and Didactic Laboratory: "Lean and Sustainability"

Abstract - The project aims at creating a Research and Didactic Lab, named "Lean and Sustainability", by using and developing enterprise games to physically simulate the processes of an enterprise, focusing on lean and sustainability concepts. The two concepts, considered together, unitary and complementary, propose a modern approach to the strategy of eliminating all the losses of any organization, being an interdisciplinary topic research.

Laboratory activities that will be proposed / developed will help students understand these concepts more easily (using the business games method), which are also modern tools used by enterprises where they will be hired as graduates. Laboratory activities will be used in existing disciplines but also in new courses to be proposed under the new master / license programs.

It is proposed to research enterprises needs to determine the issues related to the use of lean / sustainability tools and to create a new tool combining the benefits of both concepts.

"Lean and Sustainability" is a generous research theme that can be approached and developed within the "Economic Engineering Research Center".

Domain - Humanities, Social Sciences, Physical Education

**SIMON Simona-Cristina**

Project Title - Multilingual explanatory dictionary of educational terms (Romanian, English, German, French)

Abstract - The research aims at compiling an explanatory dictionary of the most frequently used educational terms that will be defined in Romanian, and translated into English, German, and French as well, thus supporting the internationalisation of UPT.



# International Research Projects





## PROJECTS SUPPORTED BY INTERNATIONAL PUBLIC FUNDS IMPLEMENTED BY PUT 2017

Field	Total number of projects	Number of projects presented
Environment	14	-
Space exploration and exploitation	2	2
Transport, telecommunication and other infrastructure	10	1
Energy	2	-
Industrial production and technology	6	6
Social and political systems, structures and processes	2	-
<b>Total</b>	<b>36</b>	<b>9</b>



## EVOLUTION OF PROJECTS SUPPORTED BY INTERNATIONAL PUBLIC FUNDS IMPLEMENTED BY PUT 2013 - 2017

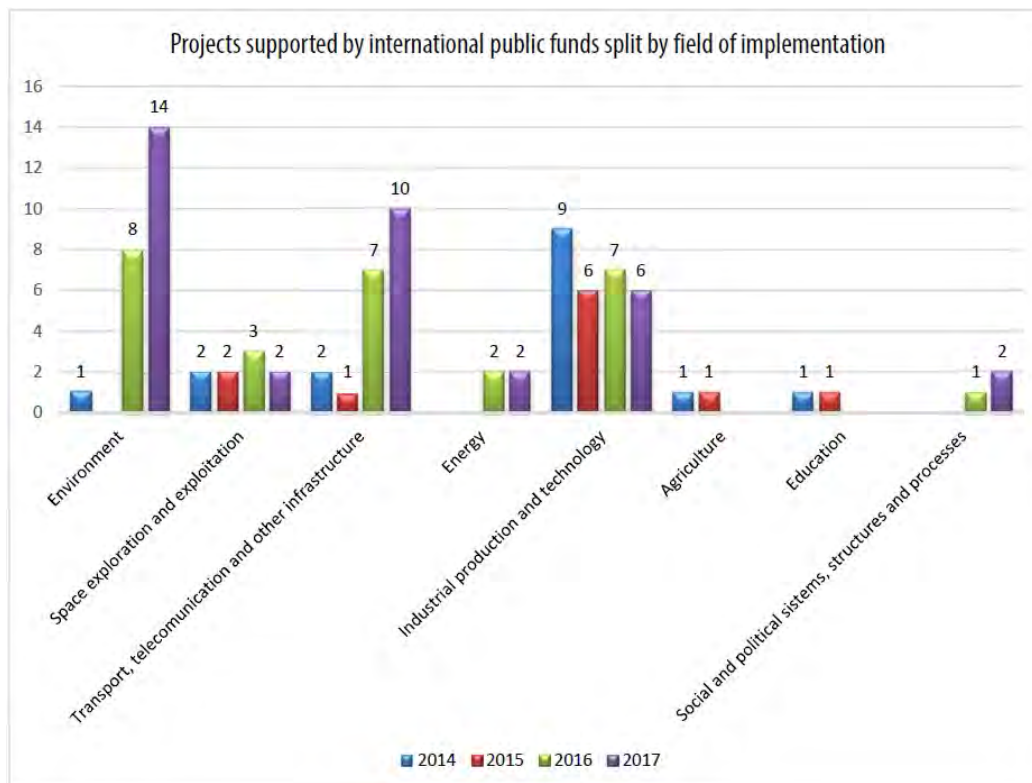



## MICRO AND NANOSCALE DESIGN OF THERMALLY ACTUATING SYSTEMS – MIDAS

### Goal of the project

A strong partnership has been organized to develop the research on shape memory alloys as materials for actuation, with well-known institutions, aiming to tackle a multitude of issues based on proven qualifications of the partners: powder metallurgy, severe plastic deformation, welding and joining, specific characterization techniques and development of applications.

### Short description of the project

The Micro and Nanoscale Design of Thermally Actuating Systems – MIDAS was successful in joining research partners from four continents in the effort to develop actuating materials belonging to the shape memory alloy group.

### Project implemented by

**Project Coordinator:** Politehnica University Timisoara, Romania (UPT)

#### EU Partners:

Universidade Nova de Lisboa, Portugal (FFCT)  
 Universitat de les Illes Balears, Spain (UIB)  
 Cranfield University, UK (CU)  
 Laboratório Nacional de Energia e Geologia, Portugal (LNEG)

#### Partners outside EU:

Universidade Federal Fluminense, Brazil (UFF)  
 University of Waterloo, Canada (WU)  
 Indian Institute of Science, India (IISc)  
 Russian Academy of Sciences (RAS)  
 University of Science and Technology Beijing, China (USTB)

### Implementation period

1.01.2014–31.12.2017

### Main activities

- WP 1 – MA Structural optimization by Mechanical Alloying
- Coordinating unit: LNEG; Partners: FFCT, UFF, UPT, USTB
- WP2 – SPD Phase control by Severe Plastic Deformation
- Coordinating unit: FFCT, IISc, UFF, RAS, USTB
- WP3 – CHR Micro and nanoscale characterization
- Coordinating unit: UIB, Partners: FFCT, UPT, LNEG, UFF, IISc, RAS, USTB
- WP4 – WJ Welding and joining techniques
- Coordinating unit: CU; Partners: WU, UPT, FFCT
- WP5 – (AD) Applicative design for smart materials integration
- Coordinating unit: UPT; Partners: RAS, LNEG, Nova.id, IME

### Results

Achievements: Materials processed via mechanical alloying technology ; Optimized technology based on experimental loops; Processed materials using SPD techniques; Microstructural maps of manufactured alloys and structures; Phase transformation parameters for the alloys and structures; Joints made out of shape memory alloys with similar and dissimilar compositions; Technological paths for different joining techniques used; joint applications for funding; prototypes; patent applications

Transfer of knowledge: Structural control by; X-Ray Diffraction; Electron microscopy (SEM, TEM) and specific sample preparation; Phase transitions (DSC, XRD, internal friction, optical microscopy); Ultrasonic, friction and electric welding; Powder metallurgy technology; Laser; Advanced design of SMA; Application development; Mechanical Testing.

Details: <http://midas.nanophys.ru/>

## Applicability and transferability of the results:

The MIDAS Project has a very high relevance for ERA because it connects through research and training important actors from Europe in the development of advanced materials at micro and nanoscale manufactured via various techniques extremely qualified partners from the world.. The partnership developed encourages collaborations in the benefit of all the partners who are themselves involved in strengthening ERA via their current activities. By the training offered in the institutions an increase of the attractiveness highly qualified people develop interesting subjects of research and could contribute to the expansion our educational interest in other countries. The MIDAS Project is in full consonance with the interest of the doctoral schools of the partners, it is expected to provide significant skills needed to develop activities in the micro and nanoengineering fields, thus increasing their chances to get a high-tech job and contribute to the development of the region.

Further opportunities to develop lasting collaboration identified during the collaboration, such as:

- Recruitment of early stage researchers for postdoctoral stages that would expand their knowledge in partners institutions.
- Identification of new patentable ideas based on the expertise of the partners.
- Stimulation of cultural interest and evaluation of opportunities to expand the institutional collaboration to other groups involved in other fields of research.

## Financed through/by

PEOPLE - MARIE CURIE ACTIONS International Research Staff Exchange Scheme  
Call: FP7-PEOPLE-2011-IRSES

## Research Centre

Department of Materials and Manufacturing Engineering

## Research team

Prof. Corneliu M. CRACIUNESCU  
Assoc. Prof. Adelina HAN  
M.Sc. Eng. Roxana SPRINCENATU  
M. Sc. Eng. Andrei NOVAC  
Eng. Mircea NICOLAESCU

## Contact information (Ex)

Prof. dr. ing. habil Corneliu Marius CRACIUNESCU  
Faculty of Mechanical Engineering /  
Department Materials and Manufacturing Engineering  
Address: Bd. Mihai Viteazul, No. 1, Postal Code 3000026, Timisoara  
Phone: (+40) 256 403 655  
Mobile: not provided or paid by the university  
E-mail: corneliu.craciunescu@upt.ro  
Web: <http://midas.nanophys.ru/>



## VALORISATION OF KNOWLEDGE FOR EUROPEAN PRE-QUALIFIED STEEL JOINTS

### Goal of the project

Seismic prequalification criteria for certain steel joint typologies were developed during the previous RFCS project, EQUALJOINTS. The current project aims to valorize, disseminate and extend the prequalification criteria for practical applications to a wide audience by producing informative documents, design guidelines and organizing seminars and workshops.

### Short description of the project

The project aims the implementation of the prequalification criteria of the steel moment resisting beam-to-column joints in the future versions of design codes.

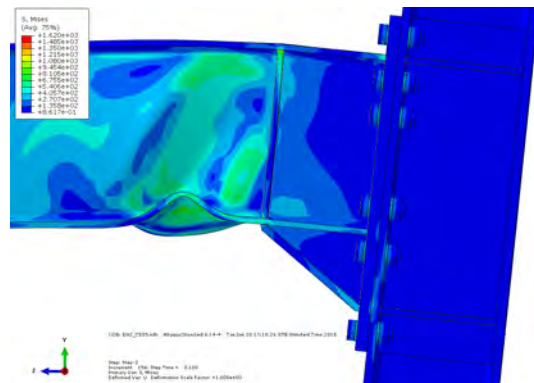
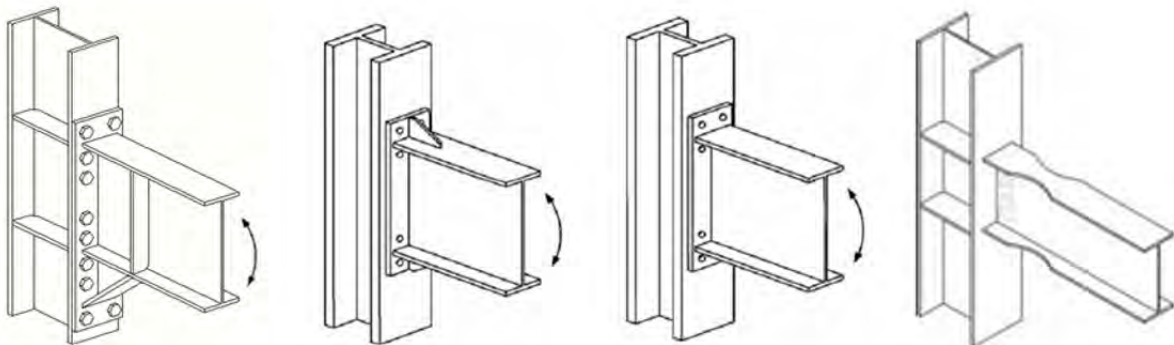

### Project implemented by

UNIVERSITA DEGLI STUDI DI NAPOLI FEDERICO II (UNINA)  
- coordinator  
ARCELORMITTAL BELVAL & DIFFERDANGE SA (AMBD)  
UNIVERSITE DE LIEGE (ULG)  
UNIVERSITATEA POLITEHNICA TIMISOARA (UPT)  
UNIVERSIDADE DE COIMBRA (UC)  
EUROPEAN CONVENTION FOR CONSTRUCTIONAL STEELWORK (ECCS)  
UNIVERSITA DEGLI STUDI DI SALERNO (UNISA)  
IMPERIAL COLLEGE OF SCIENCE TECHNOLOGY AND MEDICINE  
(Imperial)

Centre Technique Industriel de la Construction Metallique (CTICM)  
NATIONAL TECHNICAL UNIVERSITY OF ATHENS (NTUA)  
CESKE VYSOKE UCENI TECHNICKE V PRAZE (CVUT)  
TECHNISCHE UNIVERSITEIT DELFT (TU Delft)  
UNIVERZA V LJUBLJANI (UL)  
UNIVERSITET PO ARCHITEKTURA STROITELSTVO I GEODEZIJA (UASG)  
UNIVERSITAT POLITECNICA DE CATALUNYA (UPC)  
RHEINISCH-WESTFAELISCHE TECHNISCHE HOCHSCHULE AACHEN  
(RWTH AACHEN)

## Implementation period

01.07.2017 – 30.06.2019

## Main activities

- Development of informative documents for the 4 beam-to-column joints qualified within the EQUALJOINTS project and translation of these documents from English to 11 additional languages
- Development of recommendations and criteria to be used in setting up limits of applicability between EN 1993:1-8 and EN 1998-1. A set of requirements within EN 1090-2 are defined. The documents are drafted as pre-normative design recommendation in English which are translated 11 additional languages
- Development of guidelines for design and analysis of seismic resistant steel structures accounting for the behaviour of beam-to-column joints. In addition, examples for different structural systems are presented which show the influence of different joint typologies.
- Enhancement of the EQUALJOINTS Matlab software for analytical prediction of the cyclic response of joints, allowing an easy application by users in practice. Moreover, an EQUALJOINTS-app for mobile phone is developed.
- Preparation of the material to be disseminated in English and translation in the mother tongue of the places where seminars/workshop will be taken.
- Organization of workshops and seminars where the pre-normative design guidelines will be disseminated. In addition, the materials will be available in printed forms and downloadable from the project website.

## Results

The prequalification criteria for the 4 typologies of steel moment resisting beam-to-column joints from the EQUALJOINTS project (3 bolted connections and 1 reduced beam section – dog-bone) are being considered for the implementation in the next version of the design codes. The dissemination materials will be available in printed form and downloadable from the project website.

## Applicability and transferability of the results

- Use of the new versions of design codes with simplified procedures for designing steel moment resisting beam-to-column joints.
- The rotational capacity and ductility demand of the joints required by the current codes are assured using the prequalification seismic design criteria.
- Increased structural safety against the seismic hazard in large parts of Europe.
- Improvement in life cycle costs and sustainability due to the reduction of losses caused by seismic hazards.

## Financed through/by

Research Fund for Coal and Steel, grant agreement RFCS 12/04/2017 – number 754048

## Research Centre

The Research Centre for Mechanics of Materials and Structural Safety – CEMSIG

## Research Team

- Acad. Dan DUBINA
- Assoc.prof. Aurel STRATAN
- Ing. Dominiq JAKAB
- As.dr.ing. Adriana CHESOAN

## Contact information

Acad. Dan Dubina  
Faculty of Civil Engineering /  
Department of Steel Structures and Structural Mechanics,  
Ioan Curea Street No.1, 300224, Timișoara  
Phone: +40 (0) 256 403 911  
Mobile: +40 (0) 740 137 610  
E-mail: dan.dubina@upt.ro

## VALORIZATION OF INNOVATIVE ANTI-SEISMIC DEVICES (INNOSEIS)

### Goal of the project

As a result of three RFCS-, one EU- and two nationally funded research projects, 12 innovative replaceable steel-based devices have been developed that improve the response of structures during earthquakes by enhancing their energy dissipation capacity. This project aims at transferring the relevant knowledge from research to practice by the production of several documents and the organization of seminars and workshops.

### Short description of the project

UPT is responsible for valorization of removable bolted links and replaceable shear panels concepts.

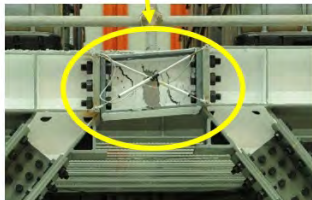

### Project implemented by

NATIONAL TECHNICAL UNIVERSITY OF ATHENS (NTUA) – coordinator  
UNIVERSITATEA POLITEHNICA TIMISOARA (UPT)  
POLITECNICO DI MILANO (POLIMI)  
UNIVERSITA DEGLI STUDI DI NAPOLI FEDERICO II. (UNINA)

UNIVERSITA DI PISA (UNIPI)  
RHEINISCH-WESTFAELISCHE TECHNISCHE HOCHSCHULE AACHEN (RWTH)  
ISTITUTO SUPERIOR TECNICO (IST)  
UNIVERSITET PO ARCHITEKTURA STROITELSTVO I GEODEZIJA (UACEG)  
UNIVERSITEIT HASSELT (UHasselt)  
MAURER SOHNE ENGINEERING GmbH & CO KG (MSE)  
EUROPEAN CONVENTION FOR CONSTRUCTIONAL STEELWORK (ECCS)

### Implementation period

01.07.2016 – 31.12.2017

### Main activities

- Collection and critical review of materials available for the anticipated devices. Information brochures were produced separately for each innovative device and then put together to form a single volume.
- Production of a document that defines a methodology for reliably quantifying values of the behavior factors  $q$  for use in seismic design.
- Clarification of cases in which devices must be qualified in accordance with EN 15129 for anti-seismic devices.
- Detailed case studies of buildings in which the innovative devices are employed.
- Seminars, workshops and other dissemination actions.

### Results

Four stories buildings, in which replaceable bolted links and replaceable shear panels are employed, were designed by UPT, in two different design cases: moderate seismicity case considering Medium Ductility Class and high seismicity case considering High Ductility Class.

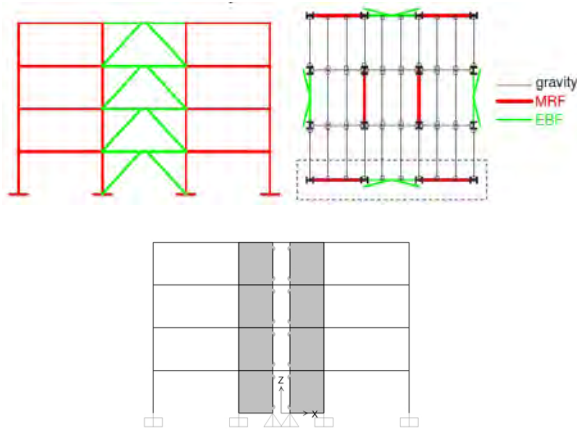

In order to verify the re-centering capability and to assess the seismic performance and feasibility of these structures, static nonlinear (pushover) analyses were performed.

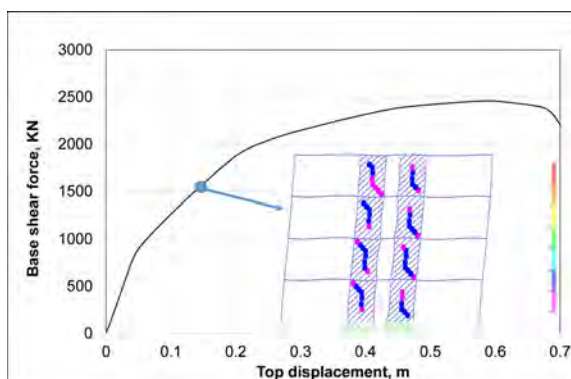
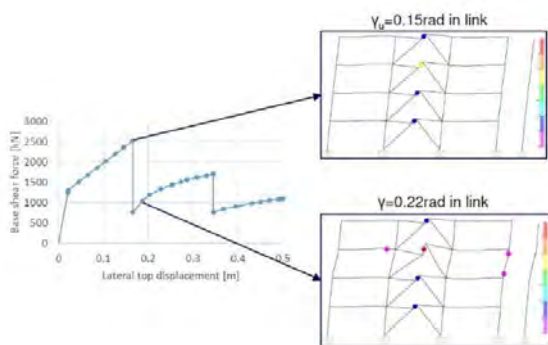

Technical documentations that describe 12 innovative systems and design guidelines to apply them were developed within the project, emphasized by case studies. These documents were distributed during the project workshop organized within 15CONMET (Iasi, Romania) and are also available on the project website (<http://in-noseis.ntua.gr/>).



## Applicability and transferability of the results

- Promotion of innovation in the design of buildings in seismic areas
- Enhancement of structural safety against the governing natural hazard in large parts of Europe.
- Improvement in life cycle costs and sustainability due to the reduction of seismic losses.
- Contribution to the increase in market share for steel, especially in areas of moderate to high seismicity where steel is underrepresented.
- Provision of more alternatives for architectural and structural design of new and existing buildings by increasing the number of code-approved structural systems for steel and composite structures.

## Financed through/by

Research Fund for Coal and Steel, grant agreement RFCS-02-2015 number 709434

## Research Centre

The Research Centre for Mechanics of Materials and Structural Safety – CEMSIG

## Research Team

- Acad. Dan DUBINA
- Assoc. prof. Aurel STRATAN
- Prof. Floarea DINU
- As.dr.ing. Adriana CHESOAN
- As.dr.ing. Calin NEAGU

## Contact information

Acad. Dan Dubina  
 Faculty of Civil Engineering /  
 Department of Steel Structures and Structural Mechanics,  
 Ioan Curea Street No.1, 300224, Timișoara  
 Phone: +40 (0) 256 403 911  
 Mobile: +40 (0) 740 137 610  
 E-mail: dan.dubina@upt.ro



## VALORISATION OF KNOWLEDGE FOR SUSTAINABLE STEEL-COMPOSITE BRIDGES IN BUILT ENVIRONMENT - SBRIPLUS

### Goal of the project

Within the RFCS project SBRI, a holistic approach to assess steel-composite bridges by combining Life Cycle Assessment (LCA), Life Cycle Costs (LCC) and Life Cycle Performance (LCP) was developed and applied to some representative bridges. This project aims at the valorisation, dissemination and extension of the developed method for advanced applications and further bridge types. To reach a wide audience among engineers and authorities, two Design Manuals and a software tool will be disseminated in the frame of several seminars across Europe.

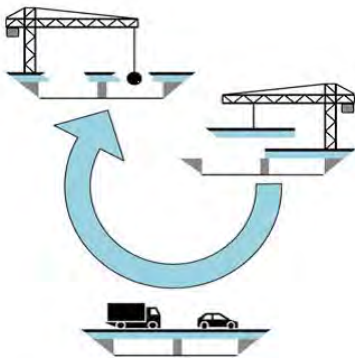

Sketch of the life-cycle of a bridge

### Short description of the project

The aim of SBRIplus project is to promote the developed knowledge and design methodologies by combining the LCA, LCC and LCP analyses along the entire life-cycle of bridges.

### Project implemented by

ArcelorMittal Belval & Differdange S.A., Luxembourg

### Implementation period

01.07.2016 – 31.06.2018

### Main activities

1. Explanation of methodology and background by elaboration of worked examples and improvement of the SBRI-tool;
2. Extension of bridge types by advanced application to innovative bridges across Europe demonstrating the flexibility and applicability of the methods developed;
3. Dissemination activities (11 European languages, organization of 13 workshops);
4. Providing of recommendations for advanced applications and guidelines for bridge authorities;
5. To provide recommendations summing up and concluding the analyses and being the bases for guidelines to be elaborated for bridge authorities.

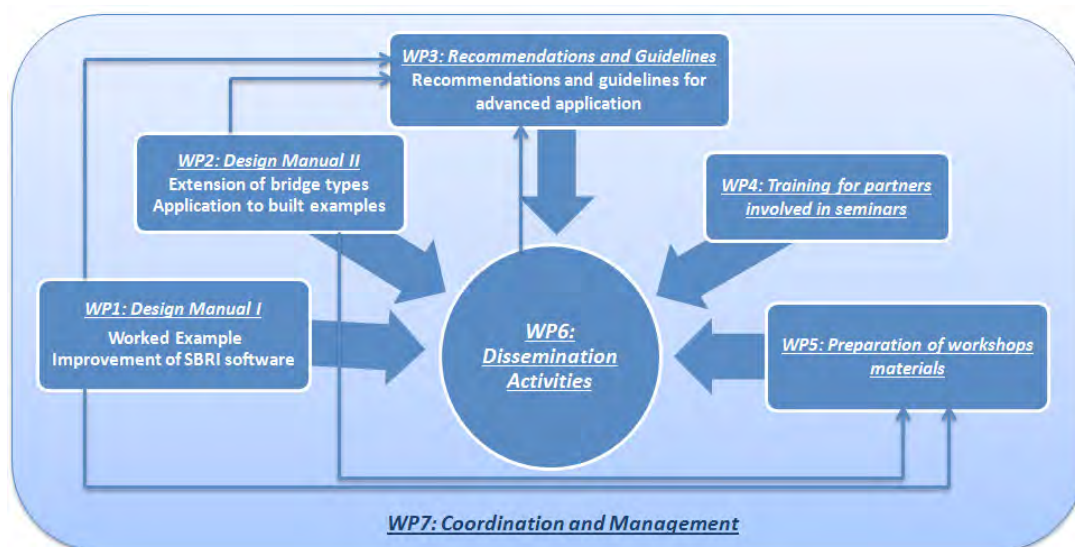

The 7 Work Packages (WPs) of the SBRIplus project

## Results

Two design manuals will be prepared and translated in 11 European languages and distributed within the planned dissemination activities. The first Design Manual includes background information on the methodology and worked examples for easy application with the help of the improved software tool. By analyses of built examples, the SBRI method will be applied to innovative bridge solutions, the results and the conclusions being shown in the second Design Manual.

The seminars around Europe will offer the opportunity to present not only the results of the SBRIplus project, but also the advanced application to innovative solutions in addition to national regulations and practice.



*The location of the seminars around Europe*

## Applicability and transferability of the results

As bridges are an integral part of the European-wide traffic infrastructure, being of vital importance for society, the amount of steel used in the construction of steel and steel-composite bridges represents an important market for the steel industry. The application of a sustainable life cycle design of bridges causes an increased steel consumption. As currently the decisive criteria at tender stage are the minimum construction costs, the needed and promoted shift to a sustainable life cycle decision making, brings the steel-composite bridges forward. The advantages of low environmental inputs, low life cycle costs and low user costs for the entire life cycle are combined in sustainable steel-composite structures. The major objective of the proposal is to valorize and transfer the knowledge gained in the SBRIplus project into practice and thus to make it available to a broad audience along engineers, authorities, bridge operators and designers.

## Financed through/by

Research Fund for Coal and Steel, grant agreement No 710068.

## Research Centre

Research Center for Mechanics of Materials and Structural Safety (CEMSIG), Politehnica University of Timișoara  
Research Institute for Renewable Energy (ICER-TM), Politehnica University of Timișoara

## Research Team

ArcelorMittal Belval & Differdange SA (Luxembourg);  
University of Stuttgart (Germany);  
University of Coimbra (Portugal);  
Aktien-Gesellschaft der Dillinger Hüttenwerke AG (Germany);  
Institut Francais des Sciences et Technologies des Transports, de l'Amenagement et des Reseaux (France);  
RAMBOLL Sverige AB (Sweden);  
BRISA Engenharia e Gestao SA (Portugal);  
FOSTA -Forschungsvereinigung Stahlanwendung e.V. (Germany);  
Politehnica University of Timisoara (Romania);  
Ceske Vysoke Uceni Technike V Praze (Czech Republic);  
Fundacion Tecnalia Research & Innovation (Spain);  
University of Naples Federico II (Italy);  
ATKINS Consultants Limited (UK);  
Stichting Bouwen met Staal (Netherlands);  
BKE sp. z o.o. (Poland);  
Sveuciliste u Zagrebu Gradevinski Fakultet (Croatia);  
S. Stathopoulos - K. Farros Consulting Engineers (Greece).

## Contact information

Prof. Viorel UNGUREANU, PhD  
Faculty of Civil Engineering  
Department of Steel Structures and Structural Mechanics  
Address: Str. Ioan Curea, No. 1, 300224, Timișoara  
Phone: (+40) 256 403912  
Mobile: (+40) 740 137640  
E-mail: viorel.ungureanu@upt.ro  
Web: www.ct.upt.ro

## TEMPERATURE ASSESSMENT OF A VERTICAL MEMBER SUBJECTED TO LOCALISED FIRE - DISSEMINATION

### Goal of the project

LOCAFI+ represents the valorisation project of the RFCS project LOCAFI the main objective of which was to provide designers with scientific evidence that will allow them designing steel columns subjected to localised fires.

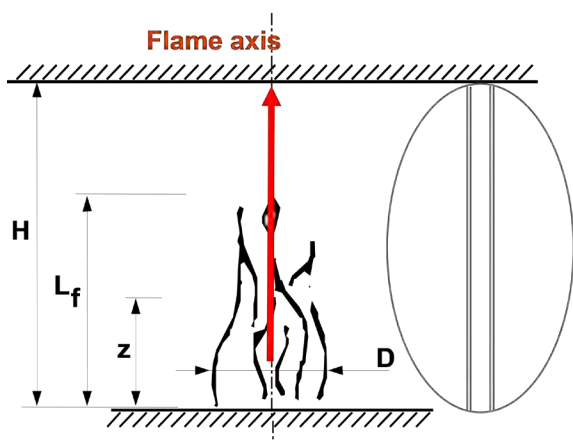
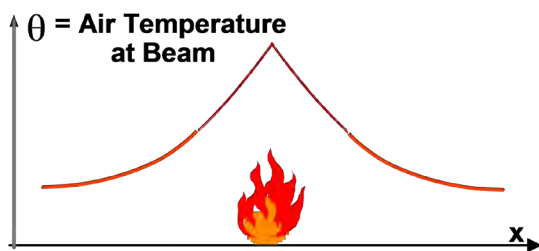
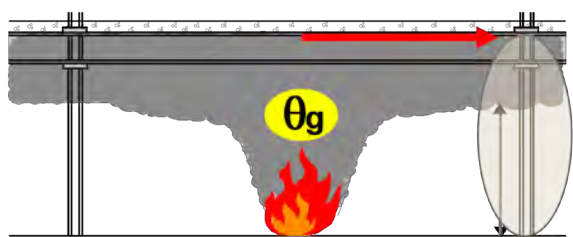

### Short description of the project

The project aims to disseminate the methodology for the fire design of columns under localised fire in several European countries, by means of national seminars.

### Project implemented by

ArcelorMittal Luxembourg (coordinator)

### Implementation period

1.07.2017-31.12.2018

### Main activities

- Development of nomograms for a wide range of different localised fires
- Development of the design guide for practitioners
- Preparation of the PowerPoint presentations for the workshops
- Adaptation of OZone software
- Translation activities and preparation of document with legal context and adapted design examples
- Preparation/ organization of the seminars
- Design of the Internet website with documents available online

### Results

An important number of seminars will be organised across Europe to present the simplified method developed within LocaFi project which will be implemented in the latest version of the European standard EN1991-1-2, its background (experimental tests, numerical investigations), user-friendly software and case studies.

### Applicability and transferability of the results

The analytical models developed within the LocaFi project were introduced in a user friendly software and in an advanced calculation model for fire design, in order to offer a large utilization of the procedure for the construction market.

## Financed through/by

EUROPEAN COMMISSION  
DIRECTORATE-GENERAL FOR RESEARCH AND INNOVATION  
Research Fund for Coal and Steel - RFCS

## Research Centre

The Research Center for Mechanics of Materials and Structural Safety  
- CEMSIG,  
Research Centre of Excellence of the Politehnic University of Timisoara

## Research Team

Prof. Raul Zaharia (coordinator for Politehnica University of Timisoara)  
Lect. Dan Pintea  
Prof. Daniel Grecea  
Assoc. Prof. Adrian Dogariu  
Lect. Ioan Both

## Contact information (Ex)

Professor Raul Zaharia  
Politehnica University of Timisoara  
Faculty of Civil Engineering  
Department of Steel Structures and Structural Mechanics  
Ioan Curea 1, Timisoara  
ROMANIA  
Tel. +40/256403922  
e-mail: raul.zaharia@upt.ro



## PROVISIONS FOR GREATER REUSE OF STEEL STRUCTURES - PROGRESS

### Goal of the project

The PROGRESS project will provide methodologies, tools and recommendations on reusing steel-based components from existing and planned buildings. The project particularly targets the design for deconstruction and reuse of envelopes, load-bearing frames, trusses and secondary elements of single-storey buildings framed in steel. This building type has broad applicability as industrial, commercial, sports, exhibition, warehouse facilities, and shows most potential in suitability for reuse and viability for circular economy business models. The whole life benefits of reusable single-storey steel buildings will be quantified from environmental and economic viewpoints. The outcomes will be extensively disseminated in particular among manufacturers, designers, contractors and researchers.



### Short description of the project

The main objective of the proposal is to develop products, systems, methods and protocols that facilitate reuse of various components of steel-framed single-storey buildings. The proposed project addresses both deconstruction and reuse of existing buildings and how new buildings can be designed, constructed and documented to facilitate future reuse. Its scope includes: (a) primary structures (frames), (b) secondary structures, (c) envelope components and hybrid multi-material systems.

### Project implemented by

VTT Technical Research Centre of Finland Ltd., (VTT, Finland)

### Implementation period

01.07.2017-30.06.2020

### Main activities

- review of the experiences from the successful reuse and deconstruction projects collected by the project partners and from the practitioners in the building industry;

**Table 1. Reuse scenarios**

	In-situ	Same site		Different site	
		Same configuration	Different configuration	Same configuration	Different configuration
Entire primary structure	A	B	C	D	E
Elements of the primary structure	N/A	N/A	F	N/A	G
Individual elements	N/A	N/A	H	N/A	I

- propose methods for the assessment of suitability of materials and elements for the reuse, including recommendations for their modification/adaptation to fit in the new design;
- propose technical recommendations for the increase of reusability of the components to be provided on component and building design levels.
- propose novel hybrid solutions for envelopes of single-storey buildings, either new buildings or renovation projects, that improves the thermal performance of the entire building, service life of envelopes and reusability of solutions themselves;
- propose a methodology to quantify and declare the environmental benefits of reused elements, resulting in recommendations on the circularity and LCA methodology;
- provide benchmark for demolition, classification and testing/verification protocols developed on a real deconstructed building including the laboratory tests to identify mechanical and chemical properties of the materials;
- design case studies to cover the most common reuse situations.

## Results

- The outcomes of the project will include recommendations to:
- Reduce the technical barriers to reuse through establishing the quality verification procedures for the structural elements and envelopes of deconstructed low-rise buildings to be reused;
  - Simplify the implementation of reusable components through recommendations for design for deconstruction and reuse, and for design using reclaimed elements as well as for safe and efficient deconstruction activities;
  - Support the product manufacturers', facility owners' and designers' decision making by recommended methodology to calculate the environmental impact and cost of steel components reusing;
  - Develop an online reused steel trading portal to co-ordinate the supply and demand for reused steel-based components;
  - Develop novel types of hybrid solutions for envelopes in order to improve the thermal performance of a building, extend the service life of an envelope and maximize the reuse potential of components.

## Applicability and transferability of the results

The majority of existing steel low-rise buildings can be deconstructed into elements such as cold-formed or hot-rolled sections, sheets, panels, frames or truss girders. These components have very high reuse potential, but require verification of the material quality, dimensions and tolerances in order to be included in new building projects. The future reuse of modern buildings, however, may be different, because those structures are increasingly designed as systems and their design information can be easily maintained for instance as a building information model (BIM).

## Financed through/by

Research Fund for Coal and Steel, EU, grant agreement No 747847.

## Research Centre

Research Center for Mechanics of Materials and Structural Safety (CEMSIG), Politehnica University of Timișoara

## Contact information

Acad. Dan DUBINA, PhD  
 Faculty of Civil Engineering /  
 Department of Steel Structures and Structural Mechanics  
 Phone: (+40) 256 403920  
 Mobile: (+40) 740 137610  
 E-mail: dan.dubina@upt.ro  
 Web: www.ct.upt.ro

Prof. Viorel UNGUREANU, PhD  
 Faculty of Civil Engineering /  
 Department of Steel Structures and Structural Mechanics  
 Research Institute for Renewable Energy (ICER-TM)  
 Address: Str. Ioan Curea, No. 1, 300224, Timișoara  
 Phone: (+40) 256 403912  
 Mobile: (+40) 740 137640  
 E-mail: viorel.ungureanu@upt.ro  
 Web: www.ct.upt.ro

## IMAGE FUSING TECHNIQUES (IMFUSING)

### Goal of the project

The Line of Sight (LoS) of a satellite could be disrupted by obstacles, reducing the accuracy of the information provided to a Global Navigation Satellite System (GNSS) receiver. The first objective of the project is to eliminate or weight the signals coming from these satellites. To simplify the identification of satellites having a direct LoS with the GNSS receiver, this project proposes, as a supplementary sensor, to use a fish eye camera.



Original image.  
The satellites were marked at Thales-Alenia.



Segmentation result (the non sky region is colored in black) obtained applying an original segmentation method developed in our research team.

The segmentation of the image provided by the fish eye camera permits to identify the satellites that are not on the LoS of the GNSS receiver

### Short description of the project

To provide sufficient information to the GNSS receiver, at the image processing level, the algorithms conceived will include the calibration of the camera sensor, image segmentation techniques, and distance and angle measurements deduced from calibrated image analysis. The algorithms at user sensor level will use camera information to discard measurements, will estimate boundaries of accuracy, will build a Quality of Service (QoS) indicator on the computed position

and will authenticate the position. The algorithms at tracking loop level will use camera information to adjust the GNSS receiver correlator.

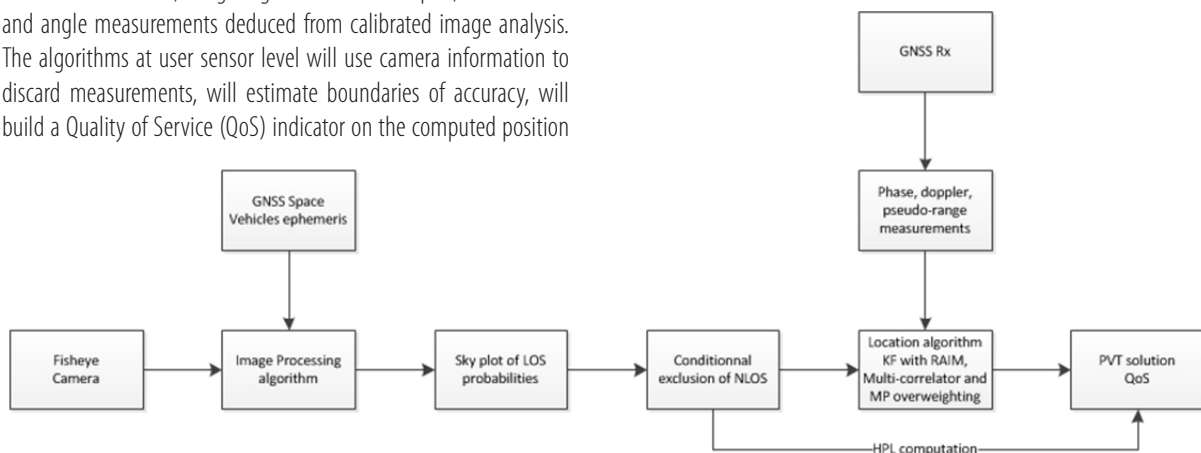

IMFUSING algorithm architecture final solution

## Project implemented by

UPT as contractor and Thales-Alenia Space France as subcontractor

## Implementation period

October 1 2014 – January 15 2018

## Main activities

Phase I 01/10/2014–31/08/2015: State of the art analysis (already validated),

Phase II September 1 2015 – January 15 2018

01/09/2015–30/06/2016: Core technical development (already validated)

01/12/2015–15/03/2017: Test campaign (validated)

15/12/2016–31/07/2017: Performance analysis (validated)

01/06/2017–15/01/2018: Dissemination and exploitation (validated)

01/02/2018–31/07/2018: 6 month support period.

## Results

Satellite localization often suffers in terms of accuracy due to various reasons. One possible source of errors is represented by the lack of means to eliminate NLoS satellite related data. IMFUSING proposes a method for fusing existing GNSS data with new information, extracted by using roof mounted cameras and adequate image processing algorithms. The roof mounted camera is used to robustly segment the sky regions. The localization approach can benefit from this new information as it offers a way of excluding the NLoS satellites. The output of the camera module is a probability map. One can easily decide which satellites should not be used for localization, by manipulating this probability map. Our approach is validated by extensive tests, which demonstrate the improvement of the localization itself (HPE) and a moderate degradation of protection levels involved in the localization (HPL).

Deliverables: Report on the State of the art in Image-GNSS fusion, Preliminary Design Review Report, Critical Design Review Report, Test Review Board Report, Executive Summary Report, MATLAB codes for developed algorithms.

Dissemination: Scientific paper in a scientific journal, Technical Note on synthesis of the study.

A first dissemination result:

Naforniță C., David C., Isar A., Preliminary results on sky segmentation, Proceedings of 2015 International Symposium Signals Circuits and Systems, 9-10 July 2015, Iasi, Romania, pp. 1-4, 10.1109/ISSCS.2015.7203933, Print ISBN: 978-1-4673-7487-3

Scientific paper at an international conference:

C. David, V. Gui, G. Carrié and others, "IMFUSING – GNSS Localization in Constraint Environment by Image Fusing Techniques". Proc. 6th CEAS Conference, October 2017, Bucharest, Romania

## Applicability and transferability of the results

The subject was evaluated at the start at technology maturity level 1 (Scientific Research), and it is aimed to conclude the project at technology readiness level (TRL) 3 (Laboratory Experiments).

## Financed through/by

European Space Agency (ESA), contract number 10031/02.08.2014 – UPT: 128.234 EURO, Thales Alenia: 70.000 EURO.

## Research centre

Intelligent Signal Processing Research Centre

## Research team

Prof. Miranda NAFORNIȚĂ PhD,  
Prof. Corina NAFORNIȚĂ PhD,  
Prof. Andrei CĂMPEANU PhD,  
Prof. Ioan NAFORNIȚĂ PhD,  
Prof. Marius OTEȘTEANU PhD,  
Prof. Vasile GUI PhD,  
Prof. Alexandru ISAR PhD,  
Assist. Prof. Ciprian DAVID PhD

## Contact information

Prof. Alexandru ISAR, PhD  
Electronics and Telecommunications Faculty/  
Communications Department/  
2 Bd. V. Pîrvan, 300223, Timișoara  
Phone: (+40) 256 403307  
Mobile: (+40) 728 009686  
E-mail: alexandru.isar@upt.ro  
Web: <http://www.tc.etc.upt.ro/isprc/>



## STUDY FOR A MONITORING STATION FOR EGNOS TO SUPPORT SERVICES IN EASTERN EUROPE

### Goal of the project

The objective of the study is the automatic reporting of EGNOS performance over Romania as well as the assessment of corrections transmitted by other SBAS.

### Short description of the project

Due to its geographical location, Romania is an ideal candidate for system performance monitoring at the border of EGNOS service area. Receivers placed in most parts of Romania will be able to track, in addition to EGNOS, also the Russian Federation's System for Differential Corrections and Monitoring (SDCM) and India's GPS Aided GEO Augmented Navigation system (GAGAN). UPT implemented within ESA regulatory framework and based on ECSS standards, all activities related to: an automatic reporting of EGNOS performance over Romania and assessment of other SBAS visible from Romania.



EGNOS Ranging and Integrity Monitoring Stations (RIMS) Sites

### Project implemented by

UPT as contractor and Thales-Alenia Space France, Pildo Labs Spain as subcontractors

### Implementation period

Sep 19 2016 – Mar 19 2018; 1 year of warranty after end of contract

### Main activities

- Management;
- Site Ranking;
- Site Selection;
- Deployment;
- Automatic Reporting & Performance Comparison;
- Communication

### Results

UPT deployed a monitoring site network, in Timisoara, Cluj-Napoca and Iasi, for the EGNOS service and all GNSS systems within Romania and archived the data for remote access by the Agency.

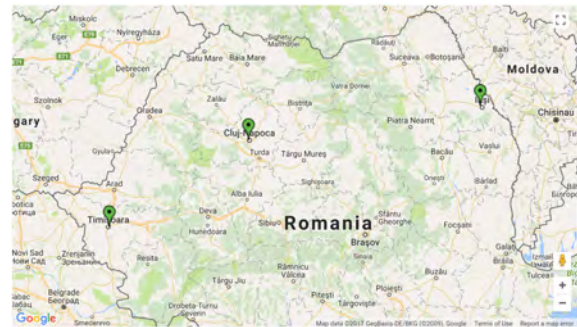

The three stations deployed at UPT-Timisoara, UTCN-Cluj and TUIASI-Iasi.

The respective locations were chosen at technical universities (UTCN and TUIASI), with whom UPT has signed hosting agreements. The user performances are monitored using the owl, a cloud service offered by Pildo Labs. The data is collected by PildoBoxes.



The antenna deployed at UPT.

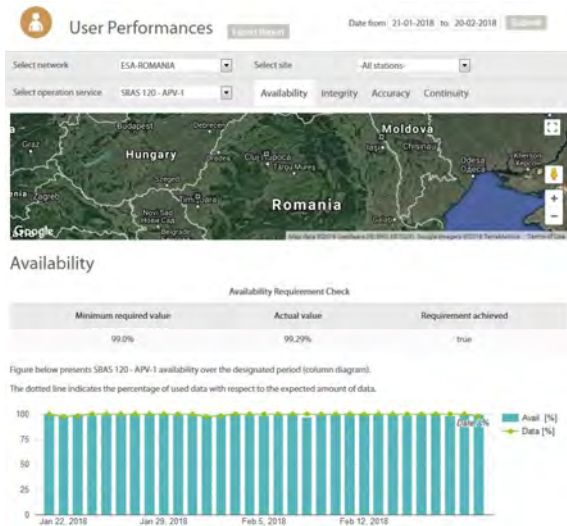

User Performances monitored using the owl cloud service: availability (SBAS 120- APV 1). This is the probability of the system being available for any given user at any given time.

### Stanford Plot Horizontal

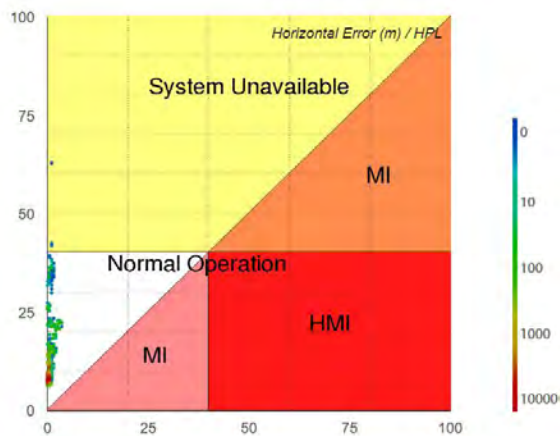

Integrity Stanford plot for UPT station (SBAS 120 – APV 1). Integrity is the system's ability to provide warnings to the user when the system is not available for a specific operation.

Deliverables: Site Selection Justification Document, Volume Simulation Plan, Service Volume Simulation Report, Hardware Deployment Plan, Hardware Deployment Report, Project Management Plan, Executive Summary Report, Financial Report, Final Report, Contract Closure Summary.

## Applicability and transferability of the results

The subject was evaluated at the start at technology maturity level 1 (Scientific Research) and is aimed to conclude the project at technology readiness level (TRL) 6: Model demonstrating the critical functions of the element in a relevant environment.

## Financed through/by

European Space Agency (ESA), contract number No. 4000 117 527 / 16/NL/CBi – UPT: 115000 EURO, Thales Alenia: 15000 EURO, Pildo Labs: 20000 EURO

## Research centre

Intelligent Signal Processing Research Centre (ISPRC)

## Research team

Prof. Corina Naforniță (Technical Manager);  
 Prof. Andrei Câmpeanu (Contracts Officer);  
 Prof. Ioan Naforniță;  
 Prof. Alexandru Isar;  
 Prof. Marius Oteșteanu

## Contact information

Prof. Corina NAFORNITA, PhD  
 Electronics and Telecommunications Faculty/  
 Communications Department/  
 2 Bd. V. Pârvan, 300223, Timișoara  
 Phone: (+40) 256 403318  
 Mobile: (+40) 722 782 359  
 E-mail: corina.nafornita@upt.ro  
 Web: <http://www.tc.etc.upt.ro/isprc/>

## LINKING TRANSNATIONAL, MULTIMODAL TRAVELLER INFORMATION AND JOURNEY PLANNERS FOR ENVIRONMENTALLY-FRIENDLY MOBILITY IN THE DANUBE REGION

### Goal of the project

There is a huge cross-border travel demand within the EU leading to hundred millions of cross-border trips every year by EU residents and further several hundred million trips by international tourists. More than 100 providers of traveller information services exist in Europe covering different levels, from local to regional, national and pan-European. The goal is to work on the inter-linking of existing services in order to enable transnational journey planning that goes beyond the territory covered by the single systems and offers travellers one seamless journey planning result.

### Short description of the project

The objective is to develop a decentralised system architecture that enables distributed journey planning.

### Project implemented by

An international consortium of journey planner- and transport operators in the frame of the INTERREG project "LinkingDanube" from Austria, Czech Republic, Hungary, Slovakia, Slovenia and Romania (with two partners, UPT and Electronic Solutions Ltd.)

### Implementation period

01.01.2017 – 30.06.2019

### Main activities

In particular the main objective is to develop a decentralised system architecture that enables distributed journey planning. By developing and establishing a common interface at each of the involved systems, the exchange of requests and results (not data) will be facilitated. The multiple responses of the involved systems have to be merged by means of an intelligent journey planner algorithm. The involved systems will engineer an application programming interface (open API) that allows bi-directional communication of the enquirer system (the system requesting information from other systems) and the responding systems. A common exchange specification will be developed that all participating systems will implement. Besides the method of implementing common gazetteers and exchange points within the distributed system will be one of the crucial points.

### Results

The actual development work of LinkingDanube will be done both on national level in a decentralised adaption of the national journey planners as well as on central level in setting up a central entity. In the end this means that national services will be able to "plug into" a common interface and provide seamless information from multiple

systems to cross-border travellers. After implementation and testing, the technical feasibility will be demonstrated for the respective regions in relevant use cases.

The pilot action will demonstrate, test and validate the developed concept and demonstrate how integrated journey planning helps to connect citizens and commuters across borders and rural regions to major hubs. In this way the demonstrations will be the basis for further large-scale implementation.

### Applicability and transferability of the results:

A central focus of LinkingDanube is the development of a concept for transnational multimodal journey planners in order to integrate the advantages of hub-to-hub-routing with local routing for cross-border regions and the elaboration of technical specifications for interface and data exchange. This concept shall build on existing structures in the partner countries, enhancing existing journey planners instead of creating a completely new structure and is completely transferable.

### Financed through/by

Co-funded by the European Union through the Joint Secretariat of the Danube Transnational Programme

### Research Centre

Dept. of Mechanical Machines, Equipment and Transportation

### Research team

Ass. Prof. Dumitru IANCUŁUI, PhD  
Sen. Lecturer Attila GÖNCZI, PhD  
Sen. Lecturer Sorin NANU, PhD  
Sen. Lecturer Octavian ȘTEFAN, PhD.

### Contact information (Ex)

Ass. Prof. Dumitru IANCUŁUI, PhD  
MECANICA/MMUT: Bv. Mihai Viteazu No.1, 300222, Timișoara  
Phone: (+40) 256 404 294  
Mobile: 0744 780 588  
E-mail: dumitru.iancului@upt.ro  
Web: <http://www.mec.upt.ro>





# PROJECTS SUPPORTED BY PRIVATE FUNDS



## PROJECTS SUPPORTED BY PRIVATE FUNDS CONTRACTED BY PUT 2017

Field	Total number of projects	Number of projects presented
Environment	41	2
Transport, telecommunications and other infrastructures	26	1
Energy	1	1
Industrial production and technology	42*	2
Health	1	-
Technological and engineering sciences	3	-
<b>Total</b>	<b>114</b>	<b>6</b>

\* *National Private Funds: 41 projects;*  
*International Private Funds: 1 project.*



## EVOLUTION OF PROJECTS SUPPORTED BY PRIVATE FUNDS CONTRACTED BY PUT 2013 - 2017

A series of inter-institutional collaborations have crucially influenced PUT's ranking classification exercise between 2013 and 2017.

Two main categories of institutional collaborations are to be noted: inter-university collaborations and collaborations with enterprises. Each of them has clearly established, mutually-shared objectives: mutual support, know-how transfer, and cooperation objectives for a common output.

PUT has always maintained a close relationship with the community, with the external environment, this relationship being its own reason to exist. Beyond the actual research and formal education, the research accomplished through technological transfer has been a constant concern for the University departments, faculties and management structures, which is reflected in the number of contracts with private companies.

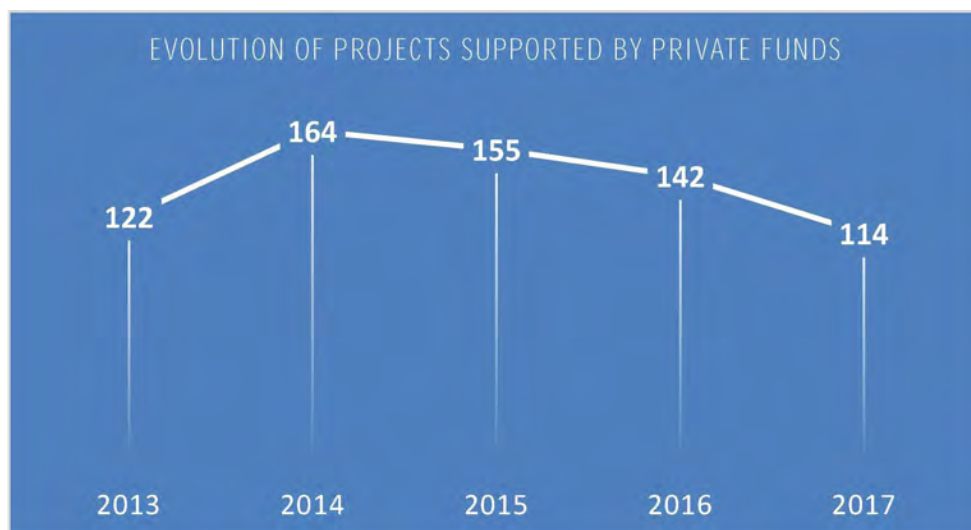

This chapter presents a selection of the research contracts with third parties.





## SOFTWARE VALIDATION OF CAMERA SYSTEMS

### Goal of the project

The goal of the project was to implement new methods that allow automation tests for embedded software of stereo camera systems. The stereo camera system is called ECU (electronic control unit).

Automation tests are tests that are implemented in a suitable environment (for instance CANoe) and which generate a final verdict, passed or failed, without any intervention of the test engineer.

### Main activities. Results

Two of these tests are presented in the following paragraphs.

The first test involves the Power Mode Control component. Thus, the power module of the camera system generates more voltages in a predefined order. Each voltage has a transition from zero Volts to the final value. This value must be within a required range. If the final value is outside of this range the software must report a so-called DEM (Diagnostic Event Manager) event.

The software test must simulate that after the voltage transition, the final value is outside the range and then it has to check if the DEM event was generated.

The test was implemented in CANoe. The following devices are controlled by CANoe: the external power supply of ECU, the DEDITECH equipment and the ECU (error memory). DEDITECH is a special equipment that mainly contains a DAC (digital to analog converter) and a switch with two positions. Thus, it allows either the voltage generated by the internal power supply of the ECU (ATIC), or the voltage generated by DAC to be connected to the microcontroller of the ECU. The aim of this project was to identify a method which can detect the transition of the voltage that must be integrated in CANoe among the existing test. Thus, in this project the LeCroy oscilloscope, which is GPIB compatible, was employed to detect the transition.

The second test involves the Heater component and is presented below.

The Heater is a device that is mounted between the camera and the windscreen of the car. It has the function of heating the surrounding area to prevent occlusion of the camera due to snow or ice that can be outside on the windscreen.

The heater actually represents an 8 ohms resistor that is periodically connected (this time is called Ton) or disconnected (Toff) to the 12V voltage of the car. The values of the Ton and Toff depend on the exterior temperature Text. They have larger values for smaller

temperatures (for instance Ton = 500 sec and Toff = 600 sec for Text = -37 degrees) and smaller values for higher temperatures. This test must verify if the dependence of the two times on the temperature is according to the requirements.

Thus this test is made by increasing the external temperature in steps of two degrees from the minimum value of -37 degrees to the maximum value of 51 degrees to cover the entire range and measure the Ton and Toff at the same time.

### Implementation period

6.01.2017-31.12.2017

### Financed through/by

Continental Automotive SRL

### Research team

Septimiu Mischie

### Contact information

Conf. Septimiu MISCHIE, PhD  
Faculty/Department Address:  
Str.Vasile Parvan, No2. 300223, Timișoara  
Phone: (+40) 256 403 364  
Mobile:  
E-mail: septimiu.mischie@upt.ro  
Web:

## MICRO-HYDRO POWER PLANTS INTEGRATION IN THE ROMANIAN POWER SYSTEM. CASE STUDY FOR CARAS-SEVERIN AREA

### Goal of the project

Power system analysis and optimization for the micro-hydro power plants' integration in the Caras-Severin area of the Romanian Power System (Enel Banat Distribution Operator).

### Short description of the project

The renewable energy sources represent an important issue for the Romanian and EU energy policy and sustainable development strategy. The projects refer to micro-hydro power plants integration in the Caras-Severin area of the Romanian Power System (Enel Banat Distribution Operator). The analysis has been performed for the North-Western, Western, Central and South-Western part of the Romanian Power System. Various operating conditions, with the consumption forecast for 2020 and 2025, were considered, taking into account all the renewable energy sources (wind, solar, biomass, hydro). The medium voltage network for the interest area has been modelled in detail.

### Project implemented by

S.C. Cons Electrificarea Instal S.R.L., Timisoara

### Implementation period

2016-2017

### Main activities

- power system data base validation;
- Enel Banat distribution network modelling; operating condition computing and analysis;
- power consumption and renewable energy generation forecast;
- power flow computing for various operating conditions of the North-Western, Western, Central and South-Western part of the Romanian Power System (peak and unloaded type operating condition for 2016, 2020, 2025 years);
- contingency analysis, in the presence / absence of the renewable energy sources.



### Results

- power flow corresponding to 2016 year and forecasted 2020 and 2025 years;
- power flow corresponding to the medium voltage electrical network (Enel Banat Timisoara area);
- voltage value without / with the new generating units;
- quick / slow maximum voltage variation value for critical buses;
- transformer loading without / with the new producers;
- power flow through the power system elements and loading level;
- integration solution validation and system reinforcement recommendations.

### Applicability and transferability of the results

Knowledge transfer to other renewable power plants developers and designers, or to the electrical distribution network operators (Enel, CEZ, EON, Electrica in Romania).

### Financed through/by

S.C. Cons Electrificarea Instal S.R.L., Timisoara

### Research Centre

Power Systems Analysis and Optimization Research Centre

### Research team

Stefan KILYENI  
Constantin BARBULESCU  
Attila SIMO  
Annamaria KILYENI

### Contact information

Prof. Stefan KILYENI, PhD  
Faculty of Electrical and Power Engineering  
Power Systems Department:  
Bd. V. Parvan, No. 2, 300223, Timisoara  
Phone: (+40) 256 403 416  
Mobile: (+40) 741 808 18  
E-mail: stefan.kilyeni@upt.ro  
Web: www.et.upt.ro

## ROBOTIC CELL FOR EXTRACTING WINE BOTTLES FROM CARDBOARD BOXES AND DEPOSE THEM IN SHUTTLES OF AUTOMATIC STORAGE

### Goal of the project

Development of a robotic cell automatizing the storage process for later delivery by order through internet. The first application is loading sealed cardboard boxes with wine bottles, feed them one by one on a cutting line, cut the top of the box, extract the bottles one by one and put them on a rotary conveyor, then tilt the bottle in the last station, get it sideways with a vacuum gripper and lay it in a shuttle on cardboard supports previously inserted by the same robot.

### Short description of the project

Wine bottle boxes are loaded, the top is cut, extracted bottles are put on rotary conveyor, tilted and laid in shuttle.

### Project implemented by

SC Acord Exclusive SRL Timisoara

### Implementation period

May-November 2017

### Main activities

The wine bottle storage module has a storage capacity of  $2 \times 12 = 24$  boxes with 6 wine bottles 750ml each, weighing  $8\text{kg} \pm 10\%$  with the dimensions  $170\text{mm} \times 250\text{mm} \times 310\text{mm}$ .

The Top cutting line may be configured manually to cut cardboard boxes with 220mm up to 280mm length, 150mm up to 200mm width and  $300\text{mm} \pm 10\%$  height.

The rotary table storage module has 24 Positioning devices for a 0,75l wine bottles.

The Cardboard support storage and delivery module stores 48...54 supports to ensure the cell functioning for 30 minutes.

### Results

The cell was developed with the technical assistance of the Research team and the financial support from the client.

The cell was tested on an experimental environment at the client's facility, and delivered to the end client

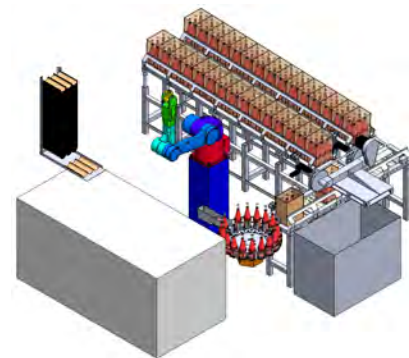

### Applicability and transferability of the results

The cell may be further developed for other types of goods, as tetra packs, bottles of other dimensions, cans and other goods in food and beverage industry, as well as goods of other kind.

### Financed through/by

Contract No. BC 99/11.10.2016, client S.C.ACORD EXCLUSIVE

### Research team

Mărgineanu Dan-Teodor,  
Lovasz Erwin-Christian,  
Ciupe Valentin,  
Mărgineanu Eugenia-Zena,  
Pop Florina,  
Pop Cristian

### Contact information

Prof. Prenume NUME, PhD  
Faculty/Department Address: Str., No. Postal Code, Timișoara  
Phone: (+40) 256 40X XXX  
Mobile:  
E-mail: prenume.nume@upt.ro  
Web

## IMAGE PROCESSING SOLUTIONS FOR EQUIPMENT TESTING IN AUTOMOTIVE INDUSTRY

### Goal of the project

The main goal of the project is to design and implement image processing solutions for equipment testing in the automotive industry. The project was divided into two themes, each one having as final result a functional experimental model. The themes are: fault detection using image processing and counting modules using image processing.

### Short description of the project

#### 1. Fault detection using image processing

The developed experimental model represents a low-cost hardware-software solution, based on image processing, that detects faults (e.g. pins, connectors, clips) on specific boards.

The main implemented functions are:

- Detection of wrong clips disposal or damaged clips;
- Detection of cracks on boards;
- Detection of crooked pins;
- Detection of missing pins;
- Detection of extra pins;
- Reporting of the whole process;
- Collecting and marking faults, data aggregation on the master equipment, creating logs, user and board selection, debug procedure, etc. within the graphical user interface;
- Managing existing boards configuration;
- Learning new boards configuration;
- Reading barcodes;
- Data exchange between the four micro-computers and communication with the higher-level traceability application.

#### 2. Counting modules using image processing

The goal of the experimental model is to provide a solution, based on image processing, for counting the boards placed by the operator in a packaging box, after the process of testing correct pins/parts/connectors disposal. The developed hardware-software system is also providing a solution for relevant data integration in a higher-level traceability application and to store relevant images over a prescribed period.

### Project implemented by

University Politehnica Timisoara,  
Department of Automation and Applied Informatics

### Implementation period

06/09/2017-30/12/2017

### Financed through/by

Hella Romania S.R.L.

### Results

#### 1. Fault detection using image processing

The developed experimental model was tested and validated in several scenarios. The developed experimental stand is depicted in fig. 1, and fig. 2 shows the four micro-computers and cameras mounted within the experimental model.



#### 2. Counting modules using image processing

The developed experimental model was tested and validated in several scenarios. The resulting image of one full packaging box, after boards detection and counting using the developed solution is depicted in fig. 3.



### Research team

Adrian Stefan KORODI, Ioan SILEA, Alexandru Brian BOITOR,  
Denis Florin ANITEI, Diana Monica BIG, Mariana Daniela GIUCHICI,  
Dorina Otelia RUSET.

### Contact information

Adrian KORODI, PhD  
Faculty of Automation and Computers Science  
Department of Automation and Applied Informatics  
Address: Bd. Vasile Parvan, No. 2, 300223, Timisoara  
E-mail: adrian.korodi@upt.ro

## ELECTRICAL DISTRIBUTION NETWORK TECHNICAL LOSSES FORECAST

### Goal of the project

Distribution network real technical losses evaluation for e-Distributie Banat Distribution System Operator. Power flow computing for various operating condition of the Western and South-Western part of the Romanian Power System has been performed.

### Short description of the project

An algorithm is proposed for technical losses forecast.

### Project implemented by

Servelect Cluj-Napoca & e-Distributie Banat Distribution System Operator

### Implementation period

2017

### Main activities

The study was conducted for e-Distributie Banat Distribution System Operator. Quantitative and qualitative on-field measurements are provided and discussed, followed by the technical losses computing based on the provided algorithm. Different necessary scenarios for the distribution network operator have been taken into consideration highlighting the optimal operating conditions.

### Results

- algorithm used for technical losses evaluation;
- 2 approaches have been developed, comparative analysis has been performed;
- electrical distribution network simulation model;
- technical losses' reduction methods.

### Applicability and transferability of the results

The algorithm used for technical losses evaluation is able to be applied in case of any distribution network operator. Also, based on the achieved experience, other (or similar) technical losses reduction methods could be highlighted in case of other distribution operators.

### Financed through/by

Servelect Cluj-Napoca, total value: 11900 RON

### Research team

Stefan KILYENI, Constantin BARBULESCU, Oana DULCA

**Consum Propriu Tehnologic**  
Regiunea REGIUNE1

Date Statistice Anuale					
Anul	CPT IT [MWh]	CPT IT [%]	Energia Intrată IT [MWh]	Contur Distribuție IT [MWh]	Energia Ieșită IT [MWh]
1	36,528	0.64%	5,712,707	675,114	5,676,179
2	37,291	0.68%	5,506,774	491,288	5,469,483
3	43,798	0.81%	5,434,017	488,320	5,390,219
4	40,523	0.73%	5,548,860	371,440	5,508,337
5	43,415	0.79%	5,491,358	590,714	5,447,943
Factor de corelație					1.000

Date Prognose Anuale					
Anul	CPT IT [MWh]	CPT IT [%]	Energia Intrată IT [MWh]	Contur Distribuție IT [MWh]	Energia Ieșită IT [MWh]
6	45,413	0.84%	5,438,559	536,780	5,373,147
6	45,086	0.83%	Metoda NUMEMETODAZ		
Abateri 0.72%					

Metoda NUMEMETODAZ					
Anul	CPT IT [MWh]	CPT IT [%]	Energia Intrată IT [MWh]		Energia Ieșită IT [MWh]
6	45,490	0.84%	5,418,600		5,373,150

Incarcare Date Statistice  
Prognoză Anuală  
Prognoză Trimestrială

Factor de Corelație: 1.000

**Consum Propriu Tehnologic**  
Regiunea Regiune1

Date Statistice Trimestriale						
Anul	CPT IT Anual [MWh]	CPT IT Trimestru 1 [MWh]	CPT IT Trimestru 2 [MWh]	CPT IT Trimestru 3 [MWh]	CPT IT Trimestru 4 [MWh]	
1	36,528	11,897	8,011	6,980	9,640	
2	37,291	10,571	8,509	7,267	10,944	
3	43,798	10,229	8,523	8,420	16,226	
4	40,523	11,435	9,320	8,385	11,382	
5	43,415	12,234	6,933	6,333	17,915	

Date Prognose Trimestriale						
Anul	CPT IT Anual [MWh]	CPT IT Trimestru 1 [MWh]	CPT IT Trimestru 2 [MWh]	CPT IT Trimestru 3 [MWh]	CPT IT Trimestru 4 [MWh]	
6	45,413	12,776	9,454	8,436	14,726	

### Contact information (Ex)

Prof. Stefan KILYENI, PhD  
Faculty of Electrical and Power Engineering /  
Power Systems Department,  
Address: V., Parvan, No. 2, 300223, Timisoara  
Phone: (+40) 256 403416  
Mobile: 0745180818  
E-mail: stefan.kilyeni@upt.ro

## MONITORING THE QUALITY OF WASTES FROM TECHNOLOGICAL PROCESS

### Goal of the project

The project objective is to monitoring the quality of wastes from technological process.

### Short description of the project

During the project various parameters of wastes are analyzed periodical from samples collected by the beneficiaries. The values of the analyzed parameters was commonly agreed upon by the beneficiaries and the execution team.

The analysis of the main parameters for the monitoring the quality of wastes is required for their according to law.

### Project implemented by

Faculty of Industrial Chemistry and Environmental Engineering.  
Department of Applied Chemistry and Engineering of Inorganic Compounds and Environmental.

### Implementation period

November 13, 2017 until November 14, 2018

### Main activities

The main activities of the project are:

- Analysis of volatile compounds (COV) from solid and liquid waste.
- Leaching testes for sludge to be placed in a class of waste.
- Analysis of the following parameters:  $\text{Cr}^{3+}$ ,  $\text{Cu}^{2+}$ ,  $\text{Ni}^{2+}$ ,  $\text{Cd}^{2+}$ ,  $\text{Pb}^{2+}$ ,  $\text{Zn}^{2+}$ , pH and humidity of the sludge.
- The main parameters are analyzed once a month in according to the project plan.

### Results

1. The volatile compounds (VOC) from waste were analyzed.
2. The concentration of heavy metals in the sludge was determined.
3. Sludge leaching testes were made.

### Applicability and transferability of the results

- Improved university–industry relationships.
- Updating curricula in accordance with the economic realities of the local area.
- The results are consistent with the legislative framework in force. Adoption by the university of new mechanisms and management techniques resulted from the project activities.

### Financed through/by

S.C. FLEXTRONICS ROMANIA S.R.L.

### Research Centre

Research Center of Environmental Sciences and Engineering

### Research team

University Lecturer Ciopec Mihaela, PhD  
Associate Professor Negrea Adina, PhD

### Contact information

University Lecturer Mihaela Ciopec, PhD  
Faculty of Industrial Chemistry and Environmental Engineering,  
Department of Inorganic and Applied Chemistry and Environmental  
Engineering, Bv. Vasile Pârvan, No. 6, RO300223, Timisoara  
Phone: (+40) 256 404192  
Mobile: 0722806880  
E-mail: mihaela.ciopec@upt.ro



## DETERMINATION ON CONCRETE QUALITY IN A STRUCTURE USING NON-DESTRUCTIVE AND DESTRUCTIVE METHODS

### Goal of the project

The in-situ characteristics of concrete may be obtained by using non-destructive and destructive tests methods. Scope of the investigation in this project was to evaluate the design compressive strength of reinforced concrete walls and columns by combination of these methods.

### Short description of the project

The load bearing capacity of reinforced concrete structural elements as walls, columns, beams and slabs are in a function of the reinforcement and concrete quality. In some situations, when there is doubt about the reliability of control and compliance results, or they are unavailable results, or these results are inappropriate, as well as the structure is damaged or deteriorated, in-situ tests are performed. There are two available test methods. The non-destructive methods are used because they are not impairing the performance of the elements or members under test, and when are applied are cause localized surface zone damage. The most common procedures are using surface hardness method by Schmidt rebound hammer and the ultrasonic pulse velocity method. The destructive methods require sample extraction, most commonly in the form of cores drilled from the concrete, which may be used in the laboratory for strength and other physical tests. The method and the number of determinations, the position of these and the investigated parameters were established previously together with the beneficiary and were correlated with the available norms and codes. The results of these tests are in the of form of reports, containing bulletins.



### Project implemented by

VOX TECHNOLOGY PARK S.R.L.  
Calea Aradului nr. 8, SAD 10A/2, etaj 9, 300088 Timișoara, jud. Timiș

### Implementation period

12.05.2017 - 12.07.2017

### Main activities

- Establishing the required number of investigations, the test methods and positions for determinations, together with the beneficiary and correlated with the available norms and codes
- Non-destructive testing using combined method of Schmidt

rebound hammer and the ultrasonic pulse velocity more than 120 zones.

- Extraction of concrete core samples in more than 11 positions.
- Preparation of core samples, by cutting to the right length and correcting using resins
- Experimental testing of the core specimens.
- Elaboration of research report and the corresponding test bulletins.

### Results

The most relevant result consists in:

- obtaining of the characteristic compressive strength of concrete elements with Schmidt rebound hammer and ultrasonic pulse velocity, as well as with combined method.
- obtaining characteristic compressive strength of concrete core specimens, as well as data resulting from visual inspection related to the type, size and distribution of the aggregates, holes, defects, cracks and material compaction.

### Applicability and transferability of the results

The experimental results obtained within the project are introduced in an advanced calculation model for structural assessment, considering the real behavior of concrete material. Results could be used to improve design and construction practice.

### Financed through/by

VOX TECHNOLOGY PARK S.R.L. through research project BC48/2017

### Research Centre

Research Centre for Retrofitting of Constructions – RECO,  
Politehnica University of Timisoara

### Research team

Tamás NAGY-GYÖRGY, Prof.  
Iosif BOROS, PhD student

### Contact information (Ex)

Prof. Tamás NAGY-GYÖRGY, PhD  
Faculty of Civil Engineering  
Department of Civil Engineering and Building Services  
Address: 2nd T. Lalescu, 300223, Timisoara  
Phone: (+40) 256 4039 35  
E-mail: [tamas.nagy-gyorgy@upt.ro](mailto:tamas.nagy-gyorgy@upt.ro)  
Web: <https://www.ct.upt.ro/users/TamasNagyGyorgy/index.htm>



## RESEARCH ON IMPROVING THE QUALITY OF LIGHTING SYSTEMS IN THE AUTOMOTIVE INDUSTRY

### Goal of the project

To transfer knowledge to the technical staff in order to improve the quality of their products by understanding the geometrical product specification method (GPS) and developing better understanding of plastics materials and processing by injection.

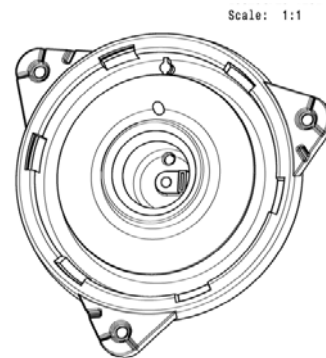
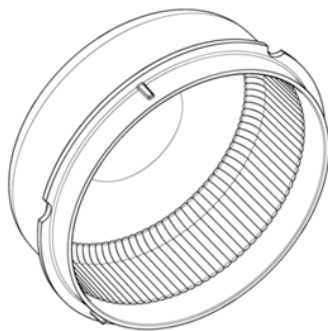

### Short description of the project

Using the GPS method to the lighting plastic injection parts.

### Project implemented by

Design Department of HRO-SA & HRO-AM, S.C. Hella Romania S.R.L., Timișoara & Lugoj

### Implementation period

14.02.2017-31.12.2017

### Main activities

Analysing the specifications for the parts and making drawings according to the ISO standards using the GPS method. Transferring knowledge for a better understanding of plastics and processing by injection, in connection with product design and manufacturing technology, highlighting solutions for avoiding the errors that cause product failure and the often met problems at the injection forming.

### Results

Transfer of geometrical product specification and tolerance analysis methods to technical staff for improving the quality of technical documentation in the design phase and during the injection process of the products. Improve the level of professional knowledge of the engineers working in plastics injection, with focus on plastic parts performance, quality assurance and manufacturing efficiency.

### Applicability and transferability of the results

The results of the project are applicable in the Hella company for improving the quality of their products and for increase the productivity. The experience accumulated with this project is very useful for monitoring and optimizing different products in other companies.

### Financed through/by

S.C. Hella Romania S.R.L.

### Research Centre

Integrated Engineering Research Center

### Research team

Conf.dr.ing. Tulcan Aurel  
Conf.dr.ing. Stan Daniel  
S.L.dr.ing. Tulcan Liliana

### Contact information (Ex)

Assoc.Prof. Aurel TULCAN, PhD  
Faculty of Mechanical Engineering /  
Department of Materials and Manufacturing Engineering  
Bld. Mihai Viteazu nr. 1, 300222-Timișoara  
SPM Building, First Floor, Room 126  
Phone: (+40) 256 403619  
Mobile: 0751 092476

## STUDY ON AIR QUALITY AT FARM LOCATION, BASED ON MEASUREMENTS AND ANALYSIS OF HARMFUL DISPERSION

### Goal of the project

Environmental laws are part of those tools that combine the rational management of natural sources with pollution prevention and control. Presently, every European country has a large number of laws (at least 100), regulating the protection of each component of the environment. They try to prevent or limit the effects of environmental degradation caused by pollution phenomena. Their character is very complex and imperative – encompassing in large part obligations to DO AND or NOT TO DO.

### Short description of the project

The purpose of the research focuses on a study for the emission inventory from the breeding area for calves and lambs of SC Barak Development SRL farm and their influence upon the vicinity. It is both an experimental research as well as an analysis by numerical modeling of the dispersions for the main pollutants produced by the cattle and sheep breeding in the Grabat village, in three variants of research: (i) the current situation (Situation I – for which one accomplished on-line measurements, used as proof of the present situation but also for the validation of the simulation), (ii) the authorized situation (Situation II) and (iii) the extension of the production capacity to 10000 calves and 8000 lambs heads (Situation III).

### Project implemented by

The project is necessary for the private company SC BARAK DEVELOPMENT SRL

### Implementation period

May 2017–September 2017

### Main activities

1. Analysis of the potential polluting sources inside the farm and outside of it
2. Establishing the three situations for the dispersion analysis
3. Identification of the main pollutants to be analyzed, as specific for animal breeding farms: NO<sub>x</sub>, PM, Non metal volatile organic compounds, benzene, methan.
4. Measuring on site, in 4 points of the air quality, with the RENAR accredited measuring system
5. Establishing of a dispersion model for the sources located in the farm and neighborhood
6. Validation of the dispersion according the results from the on line measurements and Dispersion modeling results for Situation I
7. Dispersion modeling for Situation II (approved situation already for the next future)
8. Dispersion modeling for Situation III (future planned extension/ development of the farm)

9. Identification of the pollutant concentrations in special points, located in the village (nearest house)

10. Conclusions and Recommendations

### Applicability and transferability of the results

The applicability of the research consist of the complex analysis of possible strategies, assuring the local authorities that the farm, due to its activity is not polluting over the standard limits, and does not represent a danger. Also one revealed that the farm has to take measures, especially for the next situations (strategies of developing), by taking account of applying special models for the basins and other deposits needed in its activity as young animal.

### Financed through/by

Contract BC 65/14.07.2017 cu ordered by SC BARAK DEVELOPMENT SRL for LACIEDIN (accredited RENAR lab of UPT)

### Research Centre

Research Center for Machinery and Thermal Equipment, Transport and Pollution Control, [http://www.upt.ro/Informatii\\_centrul-de-cercetari-pentru-masini-si-echipamente-termice-tr\\_109\\_ro.html](http://www.upt.ro/Informatii_centrul-de-cercetari-pentru-masini-si-echipamente-termice-tr_109_ro.html) through LACIEDIN, meaning the RENAR accredited lab of the UPT (Accreditation according SR EN ISO/CEI 17025:2005, Certificat NB LI 1151 from 05.10.2017) for fuel analysis, environmental control and dispersion of pollutants [www.mediu.ro](http://www.mediu.ro)

### Research team

Ioana IONEL, Prof. Dr. Ing. habil  
Daniel BISORCA, Dr ing.  
Ramon Mihai BALOGH As. Ing. dr. ing  
Delia Gabriela TRIF-TORDAI, Sl. dr. fiz.

### Contact information (Ex)

Prof. Ioana IONEL, PhD  
Faculty of Mechanical Engineering/  
LACIEDIN Address: Str., No. Postal Code, Timișoara  
Phone: (+40) 256 40 3670  
Mobile:(+40) 723 34 9337  
E-mail: [ioana.ionel@upt.ro](mailto:ioana.ionel@upt.ro)  
Web: [www.mediu.ro](http://www.mediu.ro)

## DESIGN AND VALIDATION OF THE MIXING SYSTEM IN A CHEMICAL REACTOR FOR CONVERSION FROM DOF TO DOTP PRODUCTION

### Goal of the project

The project was aimed at designing a new mixing rotor for a chemical reactor, in order to satisfy the new operating conditions and requirements for a two-phase liquid-solid fluid instead of the single-phase (liquid) initial design.

The project started with a preliminary numerical analysis of the existing two-blade rotor working with a liquid-solid mixture. The results showed a severe and unacceptable sedimentation of the solid phase, which would lead in poor chemical reaction kinetics.

A new mixing solution was therefore required, and this project was set to provide such a solution by replacing the existing rotor with a new one, while maintaining the same rotation speed and mechanical power.

### Short description of the project

The project had several tasks, including assessment of the existing rotor, design of a new rotor, technical drawings for the new rotor, numerical and in-situ performance validation.

### Project implemented by

The project was implemented by an interdisciplinary team (Mechanical Engineering and Chemical Engineering) from the Politehnica University Timișoara and Oltchim S.A. Rm. Vâlcea.

### Implementation period

April-December 2017

### Main activities

The first task of the project was to assess the existing mixing solution, and to establish the hydrodynamic requirements for a new mixing rotor that prevents sedimentation of the solid phase. This was done using advanced three-dimensional two-phase flow numerical simulation. Then, using the modern inverse design approach, a three-blade rotor was designed.



The new mixing solution installed and tested in-situ.

The new rotor performance was validated using numerical simulation. It was found that a two-rotor solution, provide the required homogeneous liquid-solid mixture, while completely avoiding sedimentation.

### Results

The hydrodynamically designed rotor was further simplified technologically, while preserving the mixing performance, resulting in the solution manufactured at SC Popeci Utilaj Greu, Craiova.

### Applicability and transferability of the results

The complex methodology for analysis and design of mixing rotors for liquid-solid chemical reactors can be further extended and applied for other operating conditions and reactor geometries.

### Financed through/by

Contract No. BC 99/11.10.2016, client S.C.ACORD EXCLUSIVE

### Research Centre

Research Centre for Complex Fluid Systems Engineering

### Research team

Prof. Romeo SUSAN-RESIGA, PhD  
Assoc. Prof. Adrian STUPARU, PhD  
Prof. Teodor TODINCĂ, PhD  
Asist. Prof. Alin BOSIIOC, PhD  
Eng. Mariana TODIRUȚĂ

### Contact information (Ex)

Prof. Romeo SUSAN-RESIGA, PhD  
Faculty/Department  
Address: Bvd. Mihai Viteazu, No. 1, 300222, Timișoara  
Phone: (+40) 256 403689  
Mobile: (+40) 725 890901  
E-mail: romeo.resiga@upt.ro  
Web:

# PATENTS



## EVOLUTION OF PATENTS UNDER AFFILIATIONS OF PUT 2013 - 2017

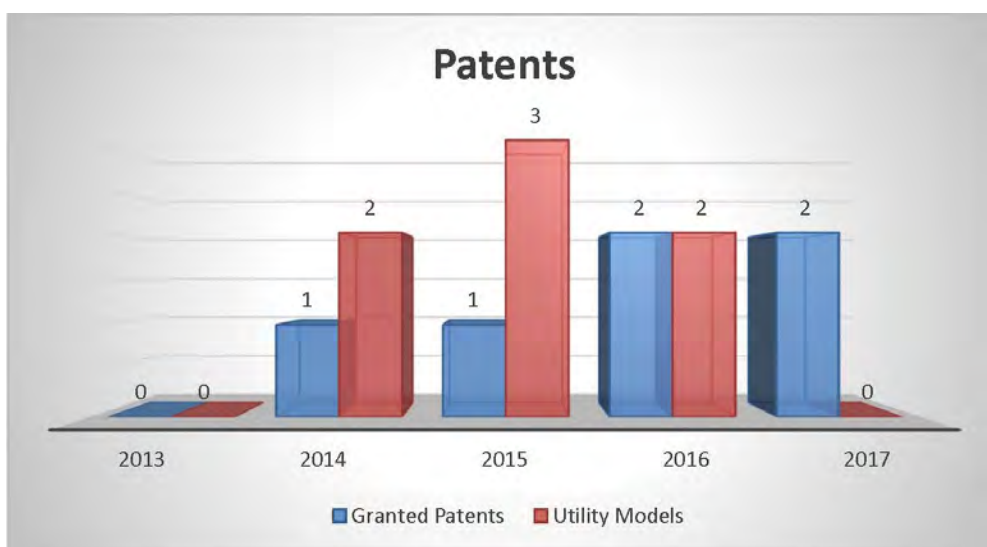

The innovative capacity of the Politehnica University of Timisoara is supported by teachers and scientific researchers through patents and utility models invented, presented in this section.





# Granted Patents



**INVENTORS: SUSAN-RESIGA ROMEO FLORIN, TANASA CONSTANTIN, BOSIOC ALIN ILIE, CIOCAN TIBERIU, STUPARU ADRIAN-CIPRIAN, MUNTEAN SEBASTIAN**

**PATENT NO. 130075 / 2017**

## **METHOD AND EQUIPMENT FOR CONTROLLING THE SWIRLING FLOW THROUGH THE CONICAL DIFFUSER OF HYDRAULIC TURBINES**



The invention relates to a method and an equipment for controlling the swirling flow through the conical diffuser of hydraulic turbines. The claimed method provides for the elimination of self-induced flow instability, the elimination of pressure fluctuations and vibrations by carrying out a progressive and controlled necking of the cross-section of a water jet flowing through a conical diffuser effected by an operator or an automation mechanism, the controlled necking being carried out in the lower region of the turbine conical diffuser, the cross-section being adjusted based on the principle of closing-opening of a circulation diaphragm which keeps in all positions the circular shape of its cross section, with the centre in the turbine main axis.

The claimed equipment for carrying out the method comprises a penstock (2) which takes over the water from an upstream lake (1) and directs it into a turbine spiral chamber (3), the water passing through a stator (4), and a directing apparatus (5) which guides the water to a rotor (6) and, due to the power generated by the rotor (6), a shaft (7) rotates a generator (8) which produces electricity, at the output of the rotor (6), the water passing through a conical diffuser (9), whose role is to convert the water kinetic energy into potential energy and, when the turbine operates at one point away from the maximum efficiency point.

The rope vortex occurs, with its associated pressure fluctuations, which are harmful to the turbine, but when an adjustable-retractable diaphragm (10) is introduced and manually adjusted by means of a handle (11) or by a servo-mechanism of an automation, the rope vortex disappears along with said pressure fluctuations, further on the water being discharged into a downstream lake (12), the diaphragm (10) being adjusted to various openings, by some diaphragm shutter elements (13).

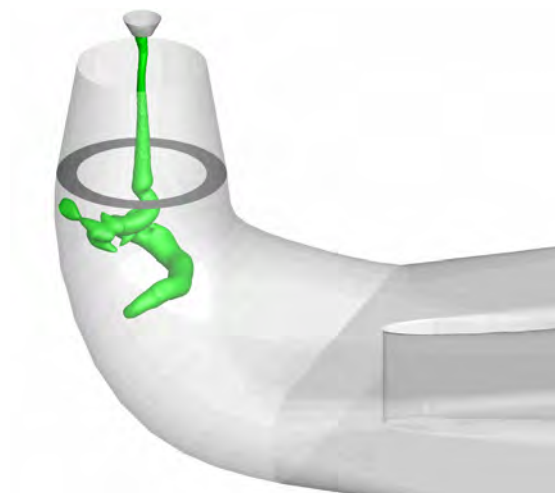
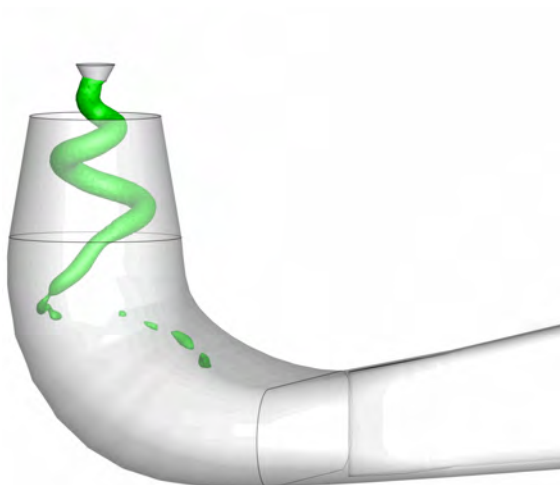
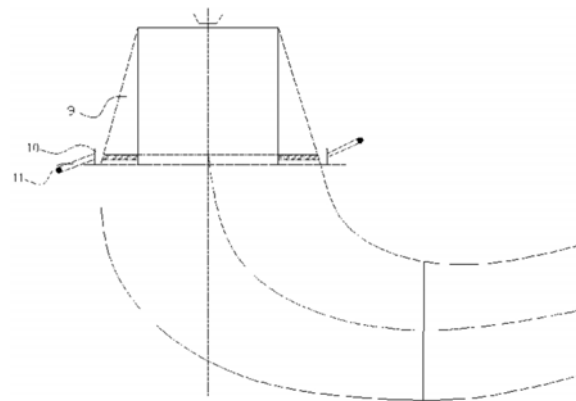
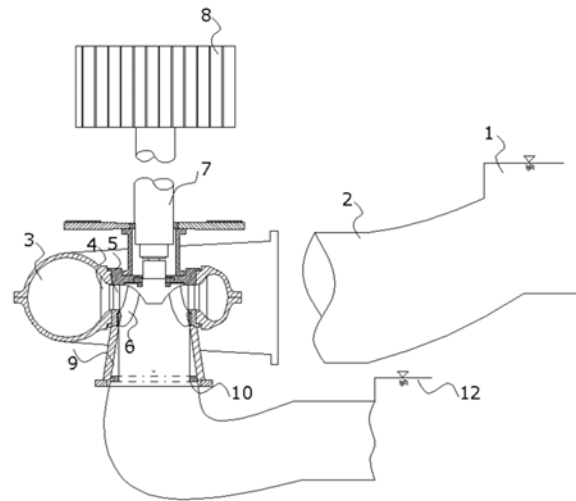

**INVENTORS: NEGREA ADINA GEORGETA, LAZAU IOAN, LUPA LAVINIA AFRODITA, LAZAU RADU IOAN, CIOPEC MIHAELA ELVIRA**

**PATENT NO. 127098 / 2017**

## PROCEDURE FOR ARSENIC REMOVAL FROM WATERS AND WASTE IMOBILIZATION IN VITREOUX MATRIX



It is well known that arsenic is a chemical element which arrives into the environment from a variety of natural and anthropogenic sources. Long term exposure leads at appearance of a large number of health problems, such as: skin affections, bladder, kidney and lungs cancer, cardiovascular and respiratory affections and in some cases can lead at diabetes. The underground sources of drinking waters represent one of the most important sources of arsenic intoxication. Into the underground water arsenic can be found as As(V) and most frequent as As(III). From this two forms the last one present higher toxicity. Present invention is related to a method of decontaminating waters with arsenic content using sludge adsorbent material containing iron and to a valorisation of exhausted adsorbent as frites, glass or ceramic glazes. The novelty of this patent is represented by a new approach, when a nonconventional material is used as adsorbent during arsenic removal from drinking waters. This new adsorbent material is represented by a sludge containing iron ions obtained as secondary product from neutralization of wastewaters containing higher quantities of metallic oxides, especially iron one. This approach, presents two different advantages, firstly representing a suitable solution for an economical problem, reducing the usage degree of natural resources, and secondly is eco-friendly by using as adsorbent sludge obtained as secondary product from other industrial process.

In conformity with present invention the sludge with higher content of iron (approximately 33%) is used as adsorbent material during purification of waters with arsenic (III) content between 10 and 700  $\mu\text{g}\cdot\text{L}^{-1}$ . As result, was obtained a waste product with higher toxicity and an arsenic content between 0.01 and 0.2%. Such waste product can be used for production of coloured glasses, or frites with higher content of  $\text{Fe}_2\text{O}_3$ .

Immobilization of arsenic waste resulted from such adsorption by inclusion into the vitreous matrix represents a new solution as also a responsible attitude, sustaining the durable development of human society.

As conclusion present invention resolves such desideratum by using the principle of close technology, by valorisation of arsenic containing waste by immobilization into the vitreous matrix, for production of glasses or ceramic decorative glazes, protecting in this way the environment.

# HONORARY MEMBERS





## EVOLUTION OF HONORARY MEMBERS OF PUT 2013 - 2017

The conferring of honorary degrees is one way in which the University recognizes individuals distinguished by accomplishments consonant with the overarching mission of the University.

Nominees may be eminent scholars, scientists, artists, or professionals who have advanced their disciplines in important ways, or they may be individuals outside of the academic world who have made particularly distinguished contributions to society.

Politehnica University of Timisoara recognizes scientific excellence by conferring the honorary degree of Doctor Honoris Causa and Honorary Professor to distinguished Researchers for their contribution to the development of PUT and continuous support.

The University strives for a robust pool of honorary degree recipients enriched by individuals from all backgrounds of engineering.

We also find it rewarding to honor individuals who have not already been publicly recognized by a number of other institutions.

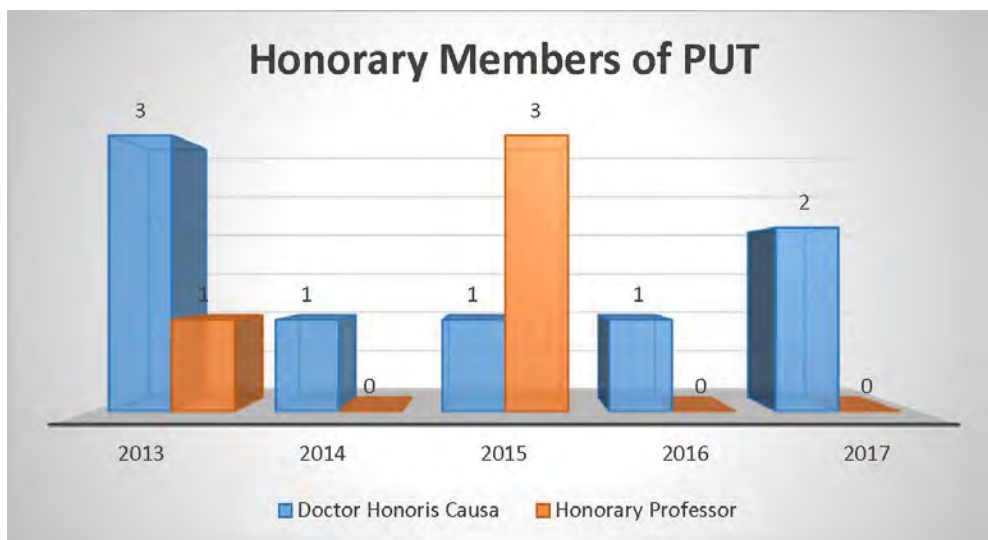



## DOCTOR HONORIS CAUSA

### Prof. Dr. Tudor BOMPA – York University, Toronto, Ontario, Canada

The Senate of the Politehnica University of Timișoara has gathered in a festive meeting today, in order to award the academic title of DOCTOR HONORIS CAUSA to Professor Tudor BOMPA, „Professor Emeritus” of the prestigious York University, Toronto, Ontario, Canada, known throughout the world as one of the top specialists, namely the one who has revolutionized training methods for athletes.

The researcher, born in Romania, has set up the “Tudor Bompa Institute” in order to promote his patented methods worldwide. For the Politehnica University of Timișoara, it is a great joy that the Professor who enjoys such wide national and international recognition should from now on add his name to the gallery of exceptional people who have been awarded this meritorious distinction. The title of Doctor Honoris Causa is the highest distinction that the University Senate may award, in recognition of personal value, but also, in this case, as a thankful recognition of the recipient’s attachment to the city of his days as a young teacher within the Polytechnic Institute of Timișoara, during the 60’s.

Professor TUDOR BOMPA was born on 23 December 1932 in the town of Nasaud, in Northern Transylvania. He attended his first school classes in his hometown, and in 1949 he moved to the Sports School in Cluj-Napoca, under the patronage of the local “Victor Babeș” University. During his junior years, he was part of the national athletics team, and won several silver and bronze medals at the National Championships, in the pentathlon, javelin and discus competitions. He attended the courses of the Institute of Physical Culture and Sports, a prestigious sports academy in the Romanian capital city, Bucharest, which he graduated at the age of 24, in 1956. In Bucharest, he activated within the Central Army House Club, with which he won six national titles at rowing and a silver medal in 1958 at the European Championship. As a student, but mainly after graduation, between 1960 and 1970, he served as Director of the Central Army House Sports Club, as university assistant professor at the Polytechnic Institute of Timișoara and the University of Bucharest, and as Athletic Director at Politehnica Timișoara Sports Club. Starting in 1960, he laid the foundations of new training methods for performance athletes, which were first published in the journal “Studies and Research” Politehnica Timișoara, T. BOMPA being part of the editorial board.

In 1970, at the age of 38, TUDOR BOMPA moved to Canada, where he continued his professional development, as follows:

He attended Master’s studies at York University, in Toronto, Canada, between 1972 and 1974.

He attended the doctoral studies program at New York State University, Buffalo, between 1975 and 1979.

He was conferred the Ph.D. degree in 1979 with the thesis: “Mechanical analysis of the action of the arms”, the work having a strong multidisciplinary nature within the field of biomechanics.

He was conferred the Ph.D. degree also by the Free University of Brussels, Belgium.

Since 2004, TUDOR BOMPA has been a member of the academic staff of York University, in Toronto, Canada, within the Department of Physical Education and Athletics, in the following teaching positions:



Assistant Professor (1971-1979), Associate Professor (1980-1992), University Professor (1993- present).

In 1998, for outstanding career merit, the prestigious York University of Toronto awarded him the title of “Professor Emeritus.”

In the following years, T. BOMPA has been training high-performance athletes, and achieved prestigious results in international sports by revolutionizing training methods. As characterized by the American Bodybuilding Magazine (2003): “Tudor Bompa is known to many as the man who single-handedly revolutionized Western training methods. After more than 40 years of work in the arena of international sports, he’s widely considered one of the world’s leading specialists when it comes to periodization, planning, peaking and strength and power lifting. Name your favorite coach and very likely he’s been strongly influenced by Tudor Bompa’s work.

As he is known all over the world, the British magazine “PeakPerformance” (2012), states that: “Tudor Bompa was called the “father” of periodization (planned training) and I am certain that there are few athletes in the world who do not owe their success (even if they do not realize), in one way or another, to the theories of the former Romanian. He is one of the world’s leading specialists. “The system and training methods of the distinguished specialist are proven by the performance of” Bompățs champions”, who won 11

medals (4 gold, 2 silver and 5 bronze) in the Olympic Games and World Championships; 3 medals (2 gold) in the Pan American Games; 22 medals in National Championships (in Canada and Romania).

Two outstanding results have crowned his permanent, uninterrupted concerns in the development and application of his methods in order to achieve the highest level of performance:

Mihaela Penes, Romanian junior, javelin, Olympic champion in Tokyo in 1964.

TUDOR BOMPA managed the physical training of young Mihaela Penes, for a year and a half in the years 1963-1964. Thus, the 17-year-old unknown, who was not taken into account after a 51-meter qualification, became Olympic champion in Tokyo with a 60.54-meter throw in the first attempt. She was the "bomb" of the Olympics, "the wonder of Tokyo," who shocked the world.

Ben Johnson, Canadian Sprinter, Olympic Champion at the 1988 Olympics in Seoul, 100 meters.

T. BOMPA's best known "product" is the Canadian Sprinter Ben Johnson. In 1988, at the Seoul Olympics, in the "race of the century", while competing with American sprinter Carl Lewis, Johnson arrived first in the 100 meter competition, with a new world record of 9.79 seconds. This was the peak of the confrontation between the two world speed titans.

Prof. Dr. TUDOR BOMPA made his studies known through publications and scientific research in the field of sports.

Thus, T. BOMPA published 15 books (8 in English), all "best sellers", translated into 18 languages: Chinese, Russian, Japanese, Italian, French, Spanish, etc., and sold in about one million copies. Most of these books are used as textbooks in universities, training institutions, certification programs, and continuing education in over 180 countries of the world. Dr. Bompa's concepts can be found in his many books, the most famous of which are:

- "Periodization: Theory and Methodology of Training", often called the "Bible" of training;
- "Periodization of Training for Sports", the most popular force training book in the world.

Besides books, he has published over 100 research papers and works on training methods. As a highly respected training specialist, Dr. TUDOR BOMPA has made presentations in over 35 countries of the world.

As T. BOMPA states, "I would not go so far as to say that I am the" father "of modern training, but I can say that my work has greatly influenced modern training. The training plan we have prepared with Ben Johnson for the Seoul Olympics has become the "Bible" in everything that has meant the world sprint.

Alongside the journalistic activity through books and scientific papers, 22 research grants are also mentioned in T. BOMPA's professional biography.

A special initiative put into practice was that he set up the "Tudor

Bompa Institute".

Together with his disciples, the American Karl Koch and the Italian Carlo Buzzichelli, the distinguished coach has laid the foundations of the Institute that nowadays bears his name, in order to promote the patented methods of the Romanian specialist throughout the world, methods that brought him numerous awards and positions in international sports organizations, as, for example:

- Director, Research and Development, Amerfit, Bloomfield, Connecticut. Responsible for the research, design and monitoring of the training of American professional and amateur athletes

- Member of the Scientific Sports Committee, United States, for the Athletics Team between 1996 and 1999, and for the Volleyball Team, between 1994 and 1995.

- Special consultant for the Canadian athletics, swimming, biking and basketball teams, for their training program for 1988 the Olympic Games.

- Member of the scientific sports committees of the following organizations: The Canadian Amateur Basketball Association (1985-1987); - The Canadian Association of Athletics (1984-1986); The Canadian Federation of Target Shooting and Squash (1985-1988).

- Corresponding Member, International Council of Health, Physical Education and Recreation (U.N.E.S.C.O.) 1978-1982.

- Delegate Member, Annual Convention of the International Rowing Federation, 1978 (Hamilton, New Zealand), 1977 (Amsterdam), 1975 (Nottingham), 1967 (Vichy), 1965 (Moscow), 1974 (Amsterdam).

Prof. TUDOR BOMPA Ph.D has received 23 distinctions and awards from prestigious institutions, governments and states: The United States of America (2014); The Iranian Government (2007); The Argentinian Ministry of Education (2006); The University of Nuevo Leon, Mexico (2006); The President of Brazil (2005); Sapienza University, Italy (2004); The Portuguese Ministry of Education (1999); The Australian Council of Sports (1993); The Spanish Olympic Committee (1989); The Canadian Olympic Committee (1985); Hamilton City Hall, New Zealand (1979).

In Romania, he was awarded the title of "Master of Sports" in 1956, and of "Citizen of Honor" of his hometown, Nasaud, in 2012.

Although he is less known in Romania, which he sadly acknowledges, TUDOR BOMPA is famous in the international sports world.

It much remains unsaid in order to sketch a complete image of the achievements of Professor TUDOR BOMPA, but more can be found in the prestigious title brochure, drafted by the members of the Specialty Commission. Based on the unequivocal conclusions presented in the file, the Senate of the Politehnica University of Timisoara unanimously expressed the will to award the title of DOCTOR HONORIS CAUSA, thus honoring a personality who has distinguished himself through scientific work, actual outstanding results and a highly professional career.

## DOCTOR HONORIS CAUSA

### Prof. Dr. Eng. Frede BLAABJERG – Aalborg University, Denmark

Born in 1963, in Denmark, Prof. Frede Blaabjerg has received his higher education and became a Ph.D. in power electronics at Aalborg University in 1995, where he is today a full Professor, after serving as Dean of Engineering-Science-Medicine Faculties (8000 students) from 2006-2013 and the Director of international Ph.D. School since 2005.

He published as an author/coauthor more than 1000 scientific papers 380 ( 800 ) in journals (conferences) in Web of science and edited 4 books, all in power electronics.

As a recognition of this prodigal activity, he earned 17 IEEE awards and has +14500 de citations in Web of science (h index 56) , +47000 in Google scholar (h index 104).

He held more than 500 lectures nationally and internationally. In addition, as a IEEE Distinguished Lecturer for two societies (PELS and IAS) he presented 45 lecturers on 4 continents, with more than 3000 attendants in all.

Based on his exceptional contribution to the massive penetration of wind energy in the Danish electric power system, Prof. Frede Blaabjerg earned National Research Award "Villum Jahn Rasmussen" (750000 euro) for 2014.

He became an IEEE Fellow in 2003.

The research activities and achievements that place him among the first 10 contributors in power electronics worldwide have been accompanied by:

- the exquisite leadership of the Aalborg University Ph.D. School from 2005; he has supervised himself 70 Ph.D. students so far.
- the reform as Dean of Engineering-Science-Medicine Faculties (2006-2013) at Aalborg University which today has diligent students from more than 60 countries (it had few foreign students in 2006);
- tripling the number of pages (with quality enhancement) of the first journal of power electronics (IEEE Transactions on PE) as Chief Editor for 7 years, from 2008 ; today the journal publishes more than 600 pages/issue (12 issues per year);
- the effort in the Danish National Research Guidance Institutions, since 2000 till today;
- the contribution as IEEE-PELS Vicepresident since 2015;
- the quality of Vicepresident of Technical Academy of Technical Sciences since 2015.



We mention here with great satisfaction Prof. Frede Blaabjerg's uninterrupted cooperation since 1997, with University Politehnica Timisoara (Prof. Ion Boldea and his younger associates), Faculty of Electrical and Power Systems Engineering.

Practically 24 Ph.D. students from UPT had at least one three month stage at Aalborg University; many joint papers at ISI Conferences and in IEEE prestigious Journals have resulted; UPT benefited many power electronics donations from Aalborg University and from Danfoss via Prof. F. Blaabjerg, who himself visited Romania 3 times (2 times at UPT).

We mention also Prof. Frede Blaabjerg modesty, honesty, compassion and generosity so visible in the 20 years of his cooperation with UPT.

In view of his outstanding scientific, didactic, managerial and professional activities at the world level and its fruitful cooperation of almost 20 years with UPT, the Senat of UPT has decided the bestow on Prof. Frede Blaabjerg from Aalborg University, Denmark the title of "Doctor Honoris Causa".

Our heartfelt congrats, Prof. Frede Blaabjerg.



# HABILITATION THESIS





## EVOLUTION OF HABILITATION THESIS IN PUT 2013 - 2017

Habilitation (from Latin *habilis* "fit, proper, skillful") is the highest academic qualification a scholar can achieve by his or her own pursuit.

In this chapter we present the habilitation thesis supported by teachers from Politehnica University of Timișoara, both at PUT and, also, at other universities.

The habilitation thesis are presented in chronological order, according to institution where they were sustained.





## MODELING, SIMULATION AND EXPERIMENTAL RESEARCH ON TECHNICAL AND BIOLOGICAL SYSTEMS

**Author: Veronica ARGEȘANU**

### Abstract

In order to optimize the functional design of a MFS one must take into account the antagonistic conditions: minimal or zero leakage and reduced friction and wear implying appropriate tribological conditions in the interface.

It is important for the operating conditions of a machine that the appropriate conditions of a machine that the appropriate sealing solution is chosen as well as the imposed conditions of the design and working are summarizing the contribution made by the author in the thesis are:

- the comparison of the limitative parameters which facilitates the chosen of the optimal solution of sealing
- the defining of the intensity of the power loss through friction in the contact area of the MFS, that can give a quantitative appreciation of the operating limits of a MFS.
- the analytical assessment of the flow-friction depending under a hydrostatic or hydrodynamic regime.
- modeling of the surface dynamic contact in the primary seal of a MFS
- the establishment of the theoretical relations of the thermo hydrodynamics of a MFS in a steady non-isothermal regime finite element analysis
- identifying the factors that influence the performance of a MFS
- mechanical and thermal modeling through computer simulations (with axially symmetric elements) of two types of MFS (EF and EF-S 103x45.4x13.3 19) manufactured by SC ROSEAL, taking into account 15 different pairs of friction materials for the primary seal of the MFS.
- the results allow the determination of other parameters (heat transfer coefficient, correction rate, etc.) that are not found in literature.
- the hypothesis of linearity of the heat flow (literature data are not confirmed)
- the effect of heat circulation in both rings simultaneously
- development of the relationship: temperature distribution-rotating rings-heat flux in the gap-geometry of the gap.

The results of modeling and computer simulation, effective in terms of input / output, being faithful to the experimental, have advanced



the accuracy of modeling and their application to other pairs of materials can be considered as valid for assessment / optimization and selection of the optimal solution of a MFS.

♦ experimental design and test equipment and establishing the experimental program;

♦ attempt under research three different seals Front (EFS 103-S; 19 x 45.4 x 13.3 EF, EF 15 x 25.7 x 12.8) and three fluids to be sealed (water at 80° C detergent, industrial water at 80° C, water with antifreeze) that confirm the results of analytical modeling research.

Theoretical issues raised during the preparation of this thesis was initiated through a cooperation agreement with SC ROSEAL S.A. – Odorheiu Secuiesc and recovered within the National Council of University Research annual research projects: “Methods and devices for testing mechanical transmissions and their components” code 280/1998.

The full abstract at:

[http://www.upt.ro/img/files/2015-2016/doctorat/abilitare/argesanu/Habilitation\\_thesis-teza\\_abilitare\\_Veronica\\_Arganu.pdf](http://www.upt.ro/img/files/2015-2016/doctorat/abilitare/argesanu/Habilitation_thesis-teza_abilitare_Veronica_Arganu.pdf)

### Habilitation Commission

Prof.univ.dr.ing. Doina PÎSLĂ  
Universitatea Tehnică din Cluj Napoca;  
Prof.univ.dr.ing. Ioan DOROFTEI  
Universitatea Tehnică “Gheorghe Asachi” din Iași;  
Prof.univ.dr.ing. Inocențiu MANIU  
Universitatea Politehnica Timișoara.

## THEORETICAL AND EXPERIMENTAL RESEARCH ON STRUCTURES AND HISTORICAL BUILDING USING ADVANCES SURVEY ENGINEERING METHODS

Author: Sorin HERBAN

### Abstract

Present thesis summarises the research activity of the candidate after defending the PhD Thesis at The Politehnica University of Timisoara and confirmed by The Ministry of Education and Research, on the basis of Order no. 5764, dated 28.11.2006.

The research activity and achievements presented in the habilitation thesis, is developed in a few of main thematic directions that are coverage by the author.

The first one is - Contribution to applying topographic methods for studying and monitoring terrain and constructions, which continues and diversifies with new subjects, the topic of the PhD Thesis or others subjects related to this.

It should be noted that the activity of the candidate in the field of special surveying engineering and applying topographic methods for studying and monitoring terrain and constructions (20 years of research in this field), from the beginning, from September 1996, until the defending of PhD Thesis, and for the post-thesis period, is in line with the fields of research of the department of Overland Communication Ways, Foundation and Cadastre and especially with the team from Terrestrial Measurements and Cadastre from Faculty of Civil Engineering, Politehnica University of Timisoara, but also with private companies and departments from EU universities.

The new subjects of research in the post-thesis period can be synthesized in four distinguish them, developed in the present thesis, each of them related to the following aspects:

- Developing methods and models to evaluate and determine the real deformations of terrain and structures.
- Reverse Engineering and Laser Scan Technology applied to Cultural Heritage domain, Development of 3D Models for Cultural Heritage sites;
- Using Open Source and Low-Cost solutions and GIS Platforms for different users to architectural and cultural applications;
- Educational platforms for e-learning processes.

The results of my scientific research are materialized mainly in speciality scientific articles and books. Therefore, I have always focused on this aspect, considering that not only the quantitative



aspect of the work is important, but also the quality and the value of the material published. It can be seen in the list of the scientific papers attached that I collaborated with colleagues from other Romanian and EU universities to contribute at enriching the literature in domain of applied Geodesy related to Civil engineering domain.

The full abstract at:

[http://www.upt.ro/img/files/2016-2017/doctorat/abilitare/herban/Rezumat\\_habilitation\\_thesis\\_en.pdf](http://www.upt.ro/img/files/2016-2017/doctorat/abilitare/herban/Rezumat_habilitation_thesis_en.pdf)

### Habilitation Commission

Prof.dr.ing. Iohan NEUNER  
Universitatea Tehnică de Construcții București;  
Prof.dr.ing. Carmen GRECEA  
Universitatea Politehnica Timișoara;  
Prof.dr.ing. Dan RĂDUCANU  
Academia Tehnică Militară București.

## NEW MATERIALS USED FOR ARSENIC REMOVAL FROM WATER

**Author: Adina Georgeta NEGREA**

### Abstract

Present habilitation thesis was structured in two different parts, and was prepared based on 31 research papers and one national patent. I am the leading author of 17 of these papers and the coauthor of 14. Of these papers, 18 are indexed in Clarivate Analytics, 12 are indexed in different other international databases, and one is a book chapter published by an international book publisher.

First part of habilitation thesis is briefly presenting my main professional, scientific, and academically achievements from the moment I defended my PhD thesis (2002) until now. During this period, I worked into the chemical engineering and in environmental protection areas. In this chapter are firstly presented the main aspects regarding the arsenic content into the worldwide natural waters as also in our country, natural and anthropic arsenic sources and the effects of his presence onto the human health, emphasizing all personal contributions. All these studies were focused on arsenic presence in West Romania ground waters, which represent a real problem. High risks associated with consumption of arsenic contaminated water made me identify new extraction materials and processes. New arsenic removal strategies emerged. Because current technology used for arsenic removal processes are quite expensive and generate too much waste and byproducts, we focused on obtaining, describing and testing new environmental friendly materials, technologies and methods. Clean technologies, such as the adsorption would recover or eliminate the arsenic from waters. Exhausted inorganic materials due to arsenic removal were immobilized in vitreous matrix used to produce decorative glazes. Organic materials used for arsenic removal were regenerated and reused for several times. Based on experimental studies can conclude that all studied material present good adsorption properties, and can be used for arsenic retention from waters in dynamic or also in static regime. Adsorption process is better described by the pseudo-second order kinetic model, is spontaneous, endotherm, and has a physical or chemical nature. Also, it was revealed that the contact surface and also the presence of iron ions present a high importance into the arsenic adsorption on studied materials.



In second part of habilitation thesis are presented the further objectives regarding didactic career, research, and further development of academic career. Present habilitation thesis contains 306 references.

The full abstract at:

[http://www.upt.ro/img/files/2016-2017/abilitare/negrea/Negrea\\_Adina\\_rezumate-ingleza.pdf](http://www.upt.ro/img/files/2016-2017/abilitare/negrea/Negrea_Adina_rezumate-ingleza.pdf)

### Habilitation Commission

Prof.univ.dr.ing. Nicolae VASZILCSIN  
Politehnica University Timișoara;  
Prof.univ.dr.ing. Dănuț-Ionel VĂIREANU  
Politehnica University București;  
Prof.univ.dr.ing., CP I Gheorghe ILIA  
Institute of Chemistry of the Romanian Academy, Timisoara Branch.

## REHABILITATION OF EXISTING CONCRETE AND/OR MASONRY STRUCTURES IN SEISMIC REGIONS. A PERMANENT CHALLENGE FOR CIVIL ENGINEERS

Author: Sorin DAN

### Abstract

The assessment of the protection level of constructions generally and particularly of reinforced concrete and/or masonry structures has become a constant preoccupation of all the specialists involved in design, construction and monitoring of structures.

The habilitation thesis presents research and case studies connected to the structural rehabilitation aspects as follows:

- Introduction to: durability problems; behaviour at seismic actions; repair and strengthening of existing structures.
- Rehabilitation of existing concrete and masonry structures: experimental research; case studies.

The vulnerability of existing structures under seismic motions may be due to structural system weaknesses and specific detailing. Structural weaknesses are characterised by various irregularities and discontinuities or by general structural vulnerabilities. Specific detailing of existing structures is function of building materials: reinforced concrete; steel; masonry; wood. The rehabilitation solutions adopted in the case of deterioration of building component parts depend on the structural material.

EXISTING REINFORCED CONCRETE STRUCTURES are strengthened in order to increase its strength, stiffness and ductility. In case of reinforced concrete framed structures, these goals are to be achieved by jacketing of beams, columns and joints. The jacketing is performed by reinforced concrete, steel profiles, carbon fibres CFRP, etc. CFRP may be used for increasing ductility and slightly increased stiffness. Experimental studies were performed on the RC jacketing strengthening method. Different techniques for increasing the bond between the old (existing) and new (jacketing) concrete layers were studied and presented in the thesis.

Experimental studies were also performed for strengthening of reinforced concrete framed structures in seismic zones by using Carbon Fiber Reinforced Polymers (CFRP). The main system's advantages as rehabilitation solution are: increase of load-carrying capacity; structures designed at gravity loads will be able to withstand seismic loads.

The reinforced concrete structures' rehabilitation case studies presented are: Western University of Timisoara; tanks supporting



structure; office building; Palace Building; apartment house affected by a gas explosion; reinforced concrete silos; industrial building; frame structure at the Timisoreana Brewery; block of flats.

EXISTING MASONRY STRUCTURES present some important vulnerability in seismic zones: the overall lateral stiffness values along the two main axes are different; lack of seismic joints to divide building parts having different dynamic characteristics; lack of reinforced concrete straps at each level; defects of wall connections at corners, crossings and ramifications as well as the presence of cracks; inadequate bearing capacity at normal forces on the walls.

Experimental research was performed on modern rehabilitation solution known as Near-Surface-Mounted Reinforcement (NSMR), which implies that steel bars/rods mainly of CFRP are bonded in sawn grooves in the masonry or concrete cover. The main advantages of this technology are: no requirement for surface preparation work, no change of the existing structure dimensions.

The masonry structures' rehabilitation solutions presented are: Banatul Museum, Timisoara – by classic solution; historical structures – by modern solution; tower structure – by modern solutions.

The full abstract at:

[http://www.upt.ro/img/files/2016-2017/doctorat/abilitare/dan/Rezumat\\_habilitation\\_thesis\\_en\\_Sorin\\_Dan.pdf](http://www.upt.ro/img/files/2016-2017/doctorat/abilitare/dan/Rezumat_habilitation_thesis_en_Sorin_Dan.pdf)

### Habilitation Commission

Prof. Nicolae TARANU  
"Gheorghe Asachi" Technical University of Iasi;  
Prof. Zoltan KISS  
Technical University of Cluj-Napoca;  
Prof. Daniel DAN  
"Politehnica" University Timisoara.

## NETWORK SCIENCE IN COMPUTER ENGINEERING AND INFORMATION TECHNOLOGY

Author: Mihai UDRESCU-MILOSAN

### Abstract

Since the beginning of the new Millennia, we have witnessed the emergence of the New Science of Complex Networks, which encompasses multiple elements from physics, mathematics, and computer science. Specifically, Complex Networks describe the structure and behavior of complex systems that can be modelled as graphs, namely mathematical structures consisting of objects, nodes, or vertices, which are connected by lines, links, or edges. As opposed to conventional graph theory, complex networks have many nodes (up to several millions) and complex irregular interconnection topology. The field of Complex Networks bridges the gap between complexity and algorithmic models, which in turn pave the way for innovative computer applications in fields such as biology, medicine, economy, social sciences, or physics.

The overarching field of Information Technology includes various approaches where computer algorithms and applications are used for the advancement of biology, medicine, pharmacology, or social physics. Indeed, the last decade has witnessed significant progress in personalized or precision medicine, based on big data techniques and computer technologies such as Complex Network Analysis, Machine Learning (including Deep Learning). Moreover, the advance in social system physics has gain a lot of momentum since the global dissemination of Online Social Networks.

Our approach to using complex networks in information technology is twofold. First, we propose new computer-based models for simulating the dynamics of opinion in social networks. Further, we validate our tolerance-based opinion diffusion model against social behavior detected in real-world data from Twitter, Facebook and Yelp. We also analyze and confirm our hypotheses by providing a comprehensive probabilistic interpretation of our tolerance-based computational model. Second, we apply a dual complex network clustering, which relies on both modularity classes and force directed network layouts, to advance the fields of network medicine and network pharmacology. In the case of network medicine, we cluster networks of Obstructive Sleep Apnea Syndrome patients, to generate patient phenotypes that can be effectively used for managing patients according to precision medicine principles. In the case of



network pharmacology, we use our dual clustering methodology to extract pharmaceutical properties for available drugs, only from information on drug-drug interactions. To this end, we build a drug-drug interaction network and process it, by algorithmically defining functional drug communities; analyzing the generated drug communities leads to recovering previous drug repositioning examples, as well as to proposing new important repositionings. Our future research will focus on applying complex networks in computer engineering. As such, we provide an extensive overview on how network analysis can be used to optimize multi-core communication in Network-on-Chip (NoC) systems. Indeed, our initial assessment proves that – from a conceptual standpoint – fractal topologies can provide a low power, reliable and performant communication infrastructure for NoCs.

The full abstract at:

[http://www.upt.ro/img/files/2016-2017/abilitare/udrescu/Rezumat\\_teza\\_abilitare\\_en\\_Udrescu.pdf](http://www.upt.ro/img/files/2016-2017/abilitare/udrescu/Rezumat_teza_abilitare_en_Udrescu.pdf)

### Habilitation Commission

Prof. Liviu MICLEA  
Technical University of Cluj-Napoca;  
Prof. Lucian VINȚAN  
“Lucian Blaga” University of Sibiu;  
Prof. Mircea VLĂDUȚIU  
Politehnica University of Timișoara.



## NANOSTRUCTURED OXIDE MATERIALS AND FUNCTIONALIZED MATERIALS WITH APPLICATIONS IN ENVIRONMENTAL PROTECTION

Author: Cornelia-Veronica MUNTEAN

### Abstract

The habilitation thesis is structured in two parts, and is based on 28 personal scientific papers (14 as lead author), of which 24 published in ISI ranked journals and 4 published in journals indexed in other international databases.

In the first part of the thesis are presented the main professional, scientific and academic achievements obtained after the candidate defended the PhD thesis in 2004.

The scientific research activity that is the subject of this thesis was directed towards the synthesis and characterization of two types of materials: nanostructured oxide materials and materials functionalized by impregnation with various extractants. Some of the materials obtained have been tested in environmental applications. These have been successfully used for the adsorption of dyes and metallic ions from dilute aqueous solutions, in view of applying these processes either for treating wastewater or for recovering valuable chemical species.

For the synthesis of nanostructured oxide materials, the thermal decomposition of carboxylate complexes (precursor) was used. This method produces oxide powders with nanometric particles at relatively low temperatures, with a yield of practically 100 %. Carboxylate precursors were obtained by the redox reaction between metal nitrates and polyols. The decomposition of carboxylates at relatively low temperatures (300-350°C) led to single/mixed oxide mixtures with high reactivity. By calcining them at suitable temperatures, the oxide systems with the desired compositions were obtained. With this new method, several spinel oxide systems with nanometric particles were prepared: ferrites  $MFe_2O_4$  ( $M = Co, Cu, Ni, Zn$ ), maghemite  $\gamma-Fe_2O_3$  and zinc aluminate  $ZnAl_2O_4$ .  $ZnO-Zn_2SiO_4-SiO_2$  nanocomposites having different compositions and properties were prepared by the sol-gel method modified by an original procedure, involving the thermal decomposition of Zn (II) carboxylates dispersed in the pores of silica gel. Cobalt, copper, nickel and zinc ferrites have been tested for adsorption of Congo red dye from aqueous solutions, and have proven to be materials with remarkable adsorbent properties.



In view of improving their adsorbent properties, magnesium silicate and Amberlite XAD7 resin have been functionalized with extractants containing nitrogen, phosphorus and sulfur functional groups (tetrabutylammonium dihydrogen phosphate, tetraethylammonium bromide, sodium  $\beta$ -glycerophosphate, and thiourea), which are considered "green", being environmentally friendly. The so-functionalized materials were used for the adsorption from aqueous solutions of rare metals ions: Eu (III), La (III) and Nd (III). Experimental results have shown that these are effective adsorbent materials, with remarkable efficiency. Moreover, these materials have the advantage that they have been obtained by easy and non-polluting methods.

In the second part of the habilitation thesis are presented the plan of evolution and development of the professional, scientific and academic career, the proposed objectives and the future research directions.

The full abstract at:

[http://www.upt.ro/img/files/2016-2017/abilitare/muntean/Rezumat\\_teza\\_abilitare\\_en\\_Muntean.pdf](http://www.upt.ro/img/files/2016-2017/abilitare/muntean/Rezumat_teza_abilitare_en_Muntean.pdf)

### Habilitation Commission

Prof.dr.ing. Rodica PODE  
Politehnica University Timisoara;  
Prof.dr.ing. Adelina-Carmen IANCULESCU  
Politehnica University Bucharest;  
Prof.dr.ing. CS1 Gheorghe ILIA  
Institute of Chemistry Timisoara of Romanian Academy.

## FROM NANOSCALE EFFECTS TO MACROSCOPIC QUANTITIES BEHAVIOR: EFFECTS OF ELECTRIC AND MAGNETIC FIELDS ON TWO-PHASE MEDIA

Author: Floriana - Daniela STOIAN

### Abstract

This thesis presents the contributions to the main research themes that continued and developed from my PhD studies, starting 1998. These main research themes are: (i) study of the liquid – vapour phase transition control by electric fields and (ii) magnetic nanofluids: heat transfer control by magnetic fields and thermal properties.

The first theme was approached in 1999, with the aim of understanding the basics of phase-change phenomena at nanoscale and how manifest at macroscopic scale in change of measurable quantities. In order to accomplish these goals, I used molecular dynamics method to study the near-critical point phase transition in either two-dimensional or three-dimensional systems, of hundreds up to one thousand molecules, interacting via Lennard – Jones potential. The study was extended to the effects of external electric fields on the structure and thermodynamic properties of these molecular systems. The results of this study matched the macroscopic observations of the electric field effect on the liquid – vapor phase transition in microgravity.

The second theme is comprising the main results in terms of my scientific contributions to three subsequent research topics concerning the use of a special class of smart materials in heat transfer related problems, which were studied in a multidisciplinary team, at the Research Center for Complex Fluid Systems Engineering, Politehnica University Timisoara, in framework of several national and international projects. The first topic envisaged the possibilities of using magnetic nanofluids as cooling agents in microgravity thermal management systems. A fundamental study was carried out with respect to the dependence of characteristic parameters of nucleate boiling with the applied magnetic field and the magnetic nanofluid magnetic properties. The second topic envisaged also fundamental aspects regarding the natural convection in water based magnetic nanofluids, in view of their use in cooling applications for automotive engineering. The third topic had both fundamental aspects as well as application-oriented, the targets being related to the use of transformer oil based magnetic nanofluids in electric transformers,



either as cooling and insulating medium in power transformers or as magnetic liquid core in high frequency planar transformers. The results of the research reported in this thesis were disseminated in 9 ISI articles and 7 ISI proceedings papers. Also, part of the scientific contributions to the second theme are included into two national patents awarded by OSIM.

The full abstract at:

[http://www.upt.ro/img/files/2016-2017/abilitare/stoian/Rezumat\\_habilitation\\_thesis\\_en\\_Stoian.pdf](http://www.upt.ro/img/files/2016-2017/abilitare/stoian/Rezumat_habilitation_thesis_en_Stoian.pdf)

### Habilitation Commission

Professor Alexandru MOREGA  
Corresponding member of the Romanian Academy,  
University Politehnica Bucharest;  
Professor Ion BOLDEA  
Member of the Romanian Academy,  
Politehnica University Timișoara;  
Professor Viorel BĂDESCU  
Member of the Romanian Academy,  
University Politehnica Bucharest.

## PROCESSES AND MATERIALS IN ELECTROCHEMICAL ENERGY SYSTEMS

**Author: Andrea KELLENBERGER**

### Abstract

The habilitation thesis entitled "Processes and materials in electrochemical energy systems" presents the main scientific, professional and academic achievements of the author after defending the PhD thesis at the Politehnica University Timisoara, together with future plans for evolution and development of the research and university career. The main research directions of the author are part of the broad area of electrochemical energy systems, with special emphasis on electrocatalysis of hydrogen evolution reaction and electrochemical synthesis of conducting polymer films and study of charge transport mechanism within such films. The entire research activity is reflected in 71 publications, of which 29 papers published in ISI ranked journals (h-index 11), author and co-author of 3 books, co-author of 1 national patent, project leader of 3 research grants and member of 1 international and 10 national research projects. The electrocatalysis of hydrogen evolution reaction is a research direction initiated in the Laboratory for Electrochemistry, Corrosion and Electrochemical Engineering of UPT. The investigations aimed at accelerating the hydrogen evolution reaction by using electrocatalysts added in the solution. These catalysts, also called proton carriers, have the ability to increase the proton concentration in the electric double layer from the metal-solution interface by transporting protons from the bulk of the solution to the interface. Various aromatic or aliphatic amines were investigated as proton carriers, since the ability to carry protons is given by the lone pair of electrons of the nitrogen atom. The originality of our work reside in that we have shown that the catalytic effect of the proton carriers is manifested not only for electrode materials with high hydrogen overpotential, such as copper, but, more important from a practical point of view, even for electrodes with low hydrogen overpotential, namely gold and platinum. Also, we have explained the catalytic effect of the amines based on their molecular parameters obtained by modeling, the most important being the dipole moment and the surface coverage degree. Thus, the highest catalytic effect was obtained for amines with a low surface coverage, which is equivalent to a larger number of molecules present at the interface, so an



increased proton concentration, and respectively for a large dipole moment, which indicates a favorable orientation of the molecules at the interface, namely with the nitrogen atom and the attached proton directed towards the metal, where the charge transfer is greatly facilitated. Considering the expertise in electrocatalysis of hydrogen evolution reaction, our research group is partner and work package leader in a HORIZON 2020 project approved for financing from 2018: "Novel modular stack design for high pressure PEM water electrolyzer technology with wide operation range and reduced cost".

The full abstract at:

[http://www.upt.ro/img/files/2016-2017/abilitare/kellenberger/Rezumat\\_teza\\_abilitare\\_en\\_Kellenberger.pdf](http://www.upt.ro/img/files/2016-2017/abilitare/kellenberger/Rezumat_teza_abilitare_en_Kellenberger.pdf)

### Habilitation Commission

Prof.univ.dr.ing. Petru ILEA  
Babeş-Bolyai University, Cluj-Napoca;  
Prof.univ.dr.ing. Rodica PODE  
Politehnica University Timișoara;  
Prof.univ.dr.ing. Dănuț-Ionel VĂIREANU  
University Politehnica of Bucharest.

## NEW GENERATION OF MATERIALS WITH APPLICATIONS IN METAL IONS REMOVAL FROM WATER

**Author: Elvira Mihaela CIOPEC**

### Abstract

Habilitation thesis entitled “New generation of materials with applications in metal ions removal from water” summarizes scientific and research activity carried out after defending my PhD thesis. Habilitation thesis was structured into three main parts: Part one – Scientific, professional and academic achievements; Part II – Proposal of professional, scientific and academic career evolution and development and Part III – References, based on 31 Thompson Reuters (ISI) indexed research papers plus 10 papers indexed in other national and international data bases. First part of habilitation thesis is shortly presenting my main professional, scientific and academic achievements from the moment when I defended my PhD thesis (2007) until present. Research directions developed and deepened during postdoctoral period are conducted in close relation with chemical engineering and environmental protection areas. Main objective of the scientific and research activity, in which I was involved was represented by preparation of a new generation of materials used in environmental protection, and especially for metal ions removal from water by using adsorption. Starting from the fact that metal ions water pollution represents one of the greatest environmental problem, a major concern is represented by their removal from water, which impose development of physical, chemical, physical-chemical and biological methods in order selective elimination of pollutants. The most eloquent method forms the economical and efficiency point of view is adsorption. Starting from these premises habilitation thesis follows the projection and development of an experimental model for production of new generation materials, whose adsorptive properties are improved through functionalization with nitrogen, phosphorus and sulfur. Two functionalization methods were used: physical (impregnation) using SIR- Solvent-Impregnated-Resin methods and chemical (synthesis) using „One–Pot” Kabatachnik–Fields reaction.

Into studies performed, in addition to classical material bearing by impregnation, also studied and mentioned in research papers, was developed a new functionalization method in dynamic regime, on the column. After obtaining and characterization of materials, these



were tested to establish their adsorption capacities for metal ions removal from water.

In this sense were performed thermodynamic, kinetic and equilibrium studies.

From studies presented was demonstrated that all obtained materials present representative performance for metal ions removal from water by adsorption and the process efficiency is higher in the case of materials obtained by the physical functionalization method – Solvent- Impregnated- Resin- SIR.

Second part of habilitation thesis present the development plan of didactic, research and academic career.

The references are included in the third part of habilitation thesis, these are 186.

The full abstract at:

[http://www.upt.ro/img/files/2016-2017/abilitare/ciopec/Mihaela\\_Ciopec-Teza\\_abilitare\\_ro.pdf](http://www.upt.ro/img/files/2016-2017/abilitare/ciopec/Mihaela_Ciopec-Teza_abilitare_ro.pdf)

### Habilitation Commission

Prof.PhD.Eng. Nicolae VASZILCSIN  
University Politehnica of Timisoara;  
Prof.PhD.Eng. Silvia CURTEANU  
“Gheorghe Asachi” Technical University of Iași;  
Prof.PhD.Eng. Dănuț-Ionel VĂIREANU  
University Politehnica of Bucharest.

## CONTRIBUTIONS TO CONTINUOUS AND DISCRETE DYNAMICAL SYSTEMS

**Author: Gheorghe TIGAN**

### Abstract

The results described in the habilitation thesis are grouped in four sections.

1) The first section describes the results we obtained on periodic, homoclinic and heteroclinic orbits in several three-dimensional differential systems, namely in Chen, Lu, T and Shimizu-Morioka systems. For the first three systems we used a method based on Lyapunov-like functions and showed that the systems under some constraints of their parameters have neither homoclinic nor closed orbits but they have heteroclinic orbits. We showed that the Chen system has two symmetrical homoclinic orbits. For the T system we studied also periodic orbits arising from Bautin bifurcation. For the Shimizu-Morioka system used a different method, namely a method based on detecting the traces left by the separatrices of a saddle point on certain surfaces. With this method we could prove the existence of homoclinic orbits in the Shimizu-Morioka system.

2) In the second section we give details about the results we obtained on nonsmooth dynamical systems. We have studied a two-dimensional discrete non-smooth system (map), which is continuous but non-differentiable with respect to one of the variables. The map generalizes in some sense the so-called Nordmark map, which is related to one-dimensional impact oscillators near grazing points. Examples of impact oscillators range from simple to complex phenomena such as, a ball bouncing on a vibrating table and a charged particle moving in strong magnetic fields in tokamaks.

3) The third section presents the results we obtained on perturbed Hamiltonian systems. We studied firstly a one-and-a-half degrees of freedom perturbed Hamiltonian system with a quartic unperturbed part and broad perturbation spectrum. An approximate interpolating Hamiltonian system was firstly studied. We pointed out results on the behavior of the Poincaré-Birkhoff dimerised chains in their routes to reconnection when the perturbation parameter varies. A discrete system associated to the full Hamiltonian system was constructed and studied.



4) In the fourth section we present details on the results we obtained on degenerate fold-Hopf bifurcations. We studied degenerate with respect to parameters fold-Hopf bifurcations in three-dimensional differential systems. Such degeneracies arise when the transformations between parameters leading to a normal form are not regular at some points in the parametric space. The fold-Hopf bifurcation (or zero-Hopf) occurs in smooth differential systems of minimum dimension three and having minimum two independent parameters. The hallmark of the bifurcation is that at certain values of the parameters the linearized system has an eigenvalue equals to zero and two purely complex eigenvalues. We obtained new generic results for the dynamics of the systems in such a degenerate framework.

The full abstract at:

<http://iosud.utcluj.ro/teze-de-abilitare.html>

### Habilitation Commission

Prof. dr. Petru JEBELEAN  
Universitatea de Vest din Timișoara;  
Prof. dr. Csaba VARGA  
Universitatea „Babeș-Bolyai” din Cluj-Napoca;  
Prof. dr. Dorian POPA  
Universitatea Tehnică din Cluj-Napoca.

# PhD THESIS



## EVOLUTION OF PhD THESIS DEFENDED IN PUT 2013 - 2017

PhD students of PUT are those with a high degree of personal motivation that stems from their natural curiosity and love of intellectual pursuits. It is expected that after they obtain their degree they will metamorphose into scholars for whom also the temptation of researching new and exciting subjects is irresistible, or at least preferable to all other choices.

Doctoral programs usually encompass intensive training in research methods, including interviewing, surveys, questionnaires, clinical trials and laboratory experiments; later, those skills are put into practice when the doctoral candidate conducts fieldwork for his dissertation. Skills gained in qualitative and quantitative research methodology and statistical analysis are transferable to non-academic research environments, particularly for industrial research. In addition, employers outside of academia seek individuals with sound research skills to carry out projects at think tanks and research institutes in both the private and government sectors.

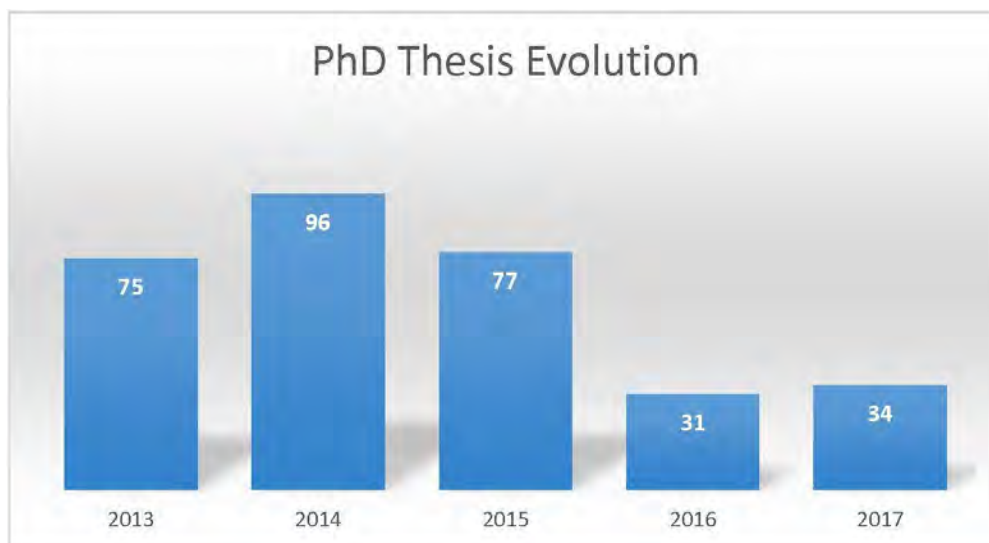

In this chapter we present a list of the PhD Thesis defended in Politehnica University of Timisoara during 2017.





## Architecture

**Mihai-Corneliu POPOVICI-DONICI**  
PhD adviser prof. T. O. GHEORGHIU

*Arhitectura neolitică și eneolitică timpurie din cultura Vinca, cultura Banatului și grupului cultural Foeni, reconstituiri arhitecturale din siturile de la Uivar, Parța și Foeni*  
( Early neolithic and eneolithic architecture in the Vinca culture, Banat culture and the Foeni cultural group. Architectural recasts for the Uivar, Parța and Foeni sites )

**Cristian MĂRĂCINEANU**  
PhD adviser prof. S. M. BICA

*Contribuții cu privire la eficiența energetică a construcțiilor rezidențiale noi în contextul dezvoltării durabile*  
( Contributions regarding the new residential constructions energy efficiency in the context of sustainable development )

**Maria TĂMĂȘAN**  
PhD adviser prof. S. M. BICA

*Muzealizarea - o modalitate de punere în valoare a patrimoniului medieval din mediul rural. Propuneri pentru județul Arad*  
( Musealisation - a way of highlighting the medieval heritage in rural areas. Proposals for Arad county )

**Daniela NEGRÎȘANU**  
PhD adviser prof. T. O. GHEORGHIU

*Locuirea ca introiecție a familiei*  
( Dwelling as an introjection of the family )

**Irina FEIER**  
PhD adviser prof. C. DUMITRESCU

*Malluri demallabile reziliență în arhitectura comercială*  
( Demallishable malls resilience in commercial architecture )

**Ștefana BĂDESCU**  
PhD adviser prof. T. O. GHEORGHIU

*Locuirea colectivă în spațiul urban contemporan. Antecedente, realități actuale, perspective*  
( Collective housing within the contemporary urban space precedents, presentday context perspectives )

## Computers and Information Technology

**Ildikó-Angelica SZŐKE**  
PhD adviser prof. V. STOICU-TIVADAR

*Contribuții la compresia imaginilor medicale digitale*  
( Contributions to the digital medical images compression )

**Florica BALOG**  
PhD adviser prof. H. CIOCĂRLIE

*Schema de distribuție a datelor în cazul stimulărilor numerice paralele de înaltă performanță alicate pentru controlul energiilor eoliene la viteză variabilă a vântului*  
( Data distribution scheme in case of the high performance parallel numeric simulations applied for the wind systems control at variable wind speed )

**Răzvan-Mihai ACIU**  
PhD adviser prof. H. CIOCĂRLIE

*Infrastructuri integrate pentru procesare distribuită*  
( Integrated frameworks for distributed computing )

**Ioan VIRAG**  
PhD adviser prof. L. STOICU-TIVADAR

*Contribuții la procesul de vizualizare și manipulare al imaginilor pseudo-holografice*  
( Contributions to the visualization process and manipulation of pseudo-holographic images )

## Systems Engineering

**Loredana GHIORGHIONI (GHORMEZ)**  
PhD adviser prof. O. PROȘTEAN

*Modelarea, identificarea și conducerea sistemelor cu arc electric. Aplicații privind cuptorul cu arc electric*  
( Modeling, identification and controlling of the systems with electric arc. Applications regarding the electric arc furnace )

## Chemical Engineering

**Roxana - Georgeta ISTRATIE**  
PhD adviser prof. C. PĂCURARIU

*Materiale avansate obținute prin metode neconvenționale cu aplicații în industrie și protecția mediului*  
( Advanced materials obtained by unconventional methods with application industrial and environmental protection )

**Monica Mariana PARASCHIVA IHOȘ**  
PhD adviser prof. R. PODE

*Degradarea electrochimică avansată a compușilor farmaceutici de tipul antiinflamatoarelor nesteroidiene - poluanți emergenți din apă, utilizând anodi cu dimensiuni stabile*  
( Advanced electrochemical degradation of nonsteroidal anti-inflammatory drugs-emergent pollutants from water, using dimensionally stable anodes )

## Chemistry

**Alexandra-Carmen GRIGORIE**  
PhD adviser prof. M. ȘTEFĂNESCU

*Sinteza și caracterizarea unor compuși oxidici nanocristalini simpli, miști și în amestec cu SiO<sub>2</sub> din azotați metalici și polioli*  
( Synthesis and characterization of simple, mixed and in mixture with SiO<sub>2</sub> nanocrystalline oxide compounds from metal nitrates and polyols )

## Civil Engineering and Building Services

**Dorin RADU**  
PhD adviser prof. R. BĂNCILĂ  
PhD adviser prof. A. SEDMAK

*Evaluarea critică a structurilor metalice cilindrice tip curbe subțiri (Shell)*  
( Engineering critical assessment of the cylindrical shell steel structures )

**Mircea MĂRGINEAN**  
PhD adviser prof. D. DUBINĂ

*Studiul robusteții structurilor în cadre metalice prin aplicarea scenariilor de cedare a stâlpilor*  
( Robustness of moment steel frames under column loss scenarios )

**Lothar BECKER-DAUGHERTY**  
PhD adviser prof. M. MARIN

*Consecințele tehnice ale exploatării miniere din Saarland, Germania*  
( Technical consequences of mining in Saarland, GERMANY )

**Remus V. CHENDEȘ**  
PhD adviser prof. C. BOB

*Determinări experimentale privind reutilizarea betoanelor rezultate din demolarea construcțiilor*  
( Experimental research on recycled concrete aggregates )

**Mihai FOFIU**  
PhD adviser prof. V. STOIAN

*Reabilitarea panourilor din beton armat prefabricate folosind lamele din CFRP aplicate pe exterior*  
( Retrofitting the precast RC wall panels using externally bonded CFRP laminates )

## Electrical Engineering

**Simona ILIE**  
PhD adviser prof. D. TOADER

*Optimizarea unei centrale termosolare cu lentilă Fresnel și motor Stirling*  
( Optimization of a thermosolar power plant with Fresnel lens and Stirling engine )

## Engineering and Management

**Andra Elena BADEA**  
PhD adviser prof. G. PROȘTEAN

*Considerații privind colaborarea verigilor lanțului logistic. Cazul proiectelor din resurse de energii regenerabile, în regim izolat*  
( Considerations regarding supply chain collaboration. The case of renewable energy resources projects, in isolated regime )

**Francisco Xavier PUJOL**  
PhD adviser prof. M. L. MOCAN

*Cum să devii o fabrică de nivel mondial: eficiență operațională, productivitatea angajaților și cultură organizațională puternică în industria auto competitivă*  
( How To Become a World Class Manufacturing Plant: Operational Efficiency, Employee Productivity And Strong Organizational Culture In The Competitive Automotive Industry )

## Materials Engineering

**Lavinia Mădălina MICU**  
PhD adviser prof. I. MITELEA  
PhD adviser prof. I. BORDEAȘU

*Comportarea la eroziune prin cavitație a oțelurilor inoxidabile Duplex*  
( Cavitation erosion behavior of Duplex stainless steels )

**Carmen-Valentina IRINA-MOISESCU**  
PhD adviser prof. I. GROZESCU

*Oxizi și nanocompozite core/shell cu diferite configurații, în sistemul TiO<sub>2</sub>-ZnO, pentru aplicații în energetică solară*  
( Oxides and different configurations of TiO<sub>2</sub>-ZnO based core/shell nanocomposites for the use in solar energetics applications )

**Dragoș Toader PASCAL**  
PhD adviser prof. V. A. ȘERBAN  
PhD adviser prof. W. BRANDL

*Dezvoltarea unor straturi funcționale compozite de tip WC-Co-NiP prin metoda brazării în vid*  
( Development of high temperature vacuum brazed WC-Co-NiP functional composite coatings )

**Cristian GHERA**  
PhD adviser prof. I. MITELEA  
PhD adviser prof. I. BORDEAȘU

*Rolul tratamentelor duplex în creșterea rezistenței la cavitație a oțelurilor pentru aparatura sistemelor hidraulice*  
( The role of duplex treatment to increasing the cavitation erosion resistance for steels used in manufacturing hydraulic equipment )

## Industrial Engineering

**Daniel CARSENTI**  
PhD adviser prof. C. D. DUMITRESCU

*Aspecte privind relația: Strategie - Managementul calității - Performanțele produsului ( cu aplicație la compania NETAFIM )*  
( Aspects of the relationship: strategy - quality management - product performances ( with application to the NETAFIM COMPANY ) )

**George Cătălin CRIȘAN**  
PhD adviser prof. D. ȚUCU

*Optimizarea sistemelor de securitate și sănătate în muncă specifice IMM din agricultură*  
( Optimising of the safety and health systems at work specific to the SME in agriculture )

## Mechanical Engineering

**Ștefan-Eusebiu KATONA**

PhD adviser prof. I. BORDEAȘU

PhD adviser prof. I. MITELEA

*Eroziunea cavitațională a oțelurilor inoxidabile cu transformare martensitică indirectă*  
( The cavitation erosion of stainless steels with indirect martensitic transformation )

**Bianca-Cristina LENGYEL**

PhD adviser prof. N. FAUR

*Cercetări privind durabilitatea înlocuitorilor de piele*  
( Researchs on the durability of leather substitutes )

**Doru Ionuț PETRESCU**

PhD adviser prof. L. BERETEU

*Studii și cercetări privind optimizarea sistemelor eoliene*  
( Research and studies regarding the optimization of wind systems )

**Geza Mihai ERDODI**

PhD adviser prof. L. BERETEU

*Cercetări în dinamica agregatelor aeroelectrice*  
( Research regarding the dynamics of aeroelectric aggregates )

**Cornelia Laura SĂLCIANU**

PhD adviser prof. I. BORDEAȘU

PhD adviser prof. I. MITELEA

*Curgerea în vanele fluture și eroziunea prin cavitație a componentelor din oțeluri inoxidabile austenitice*  
( The flow by the butterfly valves and the cavitation erosion to components by austenitic stainless steels )

**Lucian Alexandru ȘANDRU**

PhD adviser prof. V. DOLGA

*Demonstratoare mecatronice pentru robotică*  
( Mechatronics demonstrators for robotics )

# SCIENTIFIC CONFERENCES



## EVOLUTION OF SCIENTIFIC CONFERENCES 2013 - 2017

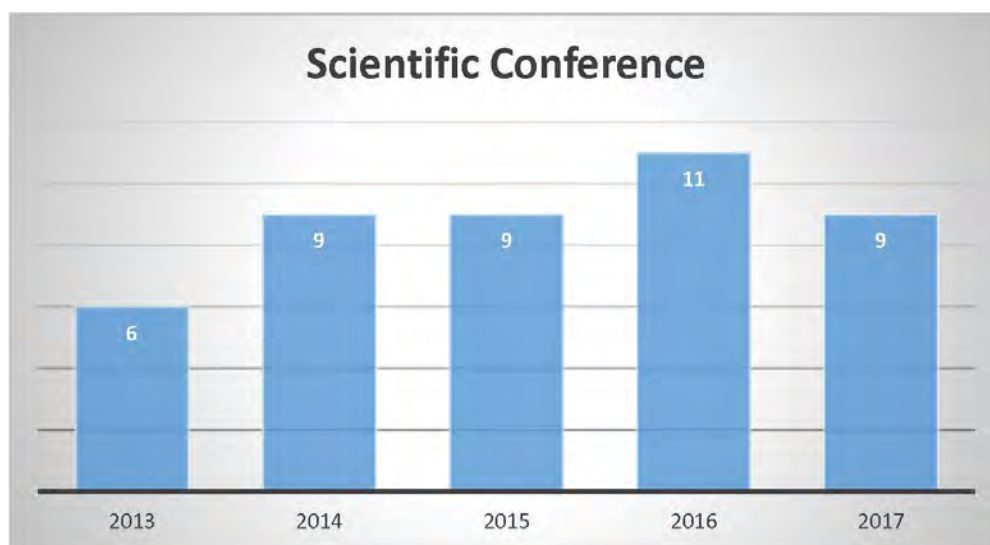







## PCTS10 – Professional Communication and Translation Studies

March 30–31, 2017, Timisoara, Romania

**Organizer:** Department of Communication and Foreign Languages, Politehnica University of Timișoara

<http://sc.upt.ro/ro/pcts10>

The international conference Professional Communication and Translation Studies has been organized by the Department of Communication and Foreign Languages since 2001. The conference aims to develop the exchange of ideas on the following topics: Communication and public relations: theoretical and didactic problems and solutions; Linguistic insights into professional communication; Translation theory and translation didactics: their roles in communication; Foreign language teaching.

The 10<sup>th</sup> anniversary edition of the conference aimed to continue the exchange of ideas on the impact of new technologies on communication, to highlight the evolution of humanities and social sciences in conjunction with technological innovation, and to identify (new) trends in the language industry in the post web 2.0 era.

Selected papers were published in the volume Professional Communication and Translation Studies (peer-reviewed, indexed by CEEOL, EBSCO, Google Scholar, Index Copernicus, MLA, ULRICH'S and WorldCat) and in the Scientific Bulletin of Politehnica University of Timisoara, Transactions on Modern Languages (peer-reviewed, indexed by CEEOL, EBSCO, ERIHPLUS, Europeana, Google Scholar, MLA, ULRICH'S and WorldCat). Languages of publication: English, French and German.



## International Conference on Applied Sciences ICAS2017

May 10–12, 2017, Hunedoara, Romania

**Organizers:** University Politehnica Timisoara & University of Banja Luka

in cooperation with: Academy of Romanian Scientists,  
Academy of Sciences Republic of Srpska,  
Academy of Technical Sciences of Romania – Timisoara Branch,  
General Association of Romanian Engineers – Hunedoara Branch

<http://www.fih.upt.ro/v4/ICAS2017/index.htm>

The conference is focused on several fields of application, operation and influence of the applied sciences and technologies on industry.

Topics of the conference covers a comprehensive spectrum of issues from:

1. Materials Science: Metallic Materials, Composite Materials, Metal Alloys, Metallurgy, Heat Transfer, and others ...
2. Mechatronics: Mechanical Engineering, Robotic Systems Engineering, Control Engineering, Reliability, and others ...
3. Electrical Engineering: Circuits and Systems, Signal Processing, Electric Motors, and others ...
4. Computers Engineering: Modeling and Simulation, Computational Methods in Engineering, Software Engineering, Data Bases, and others ...
5. Fundamental Sciences: Numerical approximation and analysis, Interdisciplinary applications of mathematics and physics, Chemistry, and others ...

Publication of papers:

- Proceedings of ICAS2017: published in IOP Conference Series: Materials Science and Engineering vol. 294 (2018)
- Proceedings of ICAS2016: published in IOP Conference Series: Materials Science and Engineering vol. 163 (2017)

indexed by Thomson Reuters – Web of Sciences and Scopus

- Proceedings of ICAS2015: published in IOP Conference Series: Materials Science and Engineering vol. 106 (2016)

indexed by Thomson Reuters – Web of Sciences and Scopus

Participation is open to all persons interested in this conference. For registered speakers who have no possibility to travel at the conference location, there has been organized a Video-conference session.

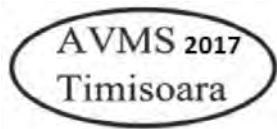

## 14<sup>th</sup> International Conference "Acoustics and Vibration of Mechanical Structures" – AVMS-2017

May 25 – 26, 2017, Timisoara, Romania

- Organizers:** a) University Politehnica Timisoara – Acoustics and Vibration Laboratory  
b) Romanian Academy, Branch of Timisoara  
– Center for Fundamental and Advanced Technical Research  
c) University of Nis, Serbia, Noise and Vibration Laboratory  
d) Romanian Acoustical Society  
e) AGIR, Branch of Timisoara

[www.mec.upt.ro/meca/avms/main.php](http://www.mec.upt.ro/meca/avms/main.php)

- AVMS-2017 Conference was intended to serve as a platform for researchers, engineers, academicians, as well as professionals from industry to present and discuss their latest research results in the field of noise and vibration.
- AVMS-2017 conference focuses on Noise and vibration control Noise and vibration generation and propagation; Effects of noise and vibration; Condition monitoring and vibration testing; Nonlinear acoustics and vibration; Analytical, numerical and experimental techniques for noise and vibration; Modeling, prediction and simulations of noise and vibration; Environmental and occupational noise and vibration; Noise and vibration attenuators; Regulations requirements and quality assurance systems related to acoustics/vibration; Biomechanics and bioacoustics

Publication of papers:

Accepted papers after review were published by "Springer Proceedings in Physics", ISSN 0930-8989

<https://link.springer.com/book/10.1007/978-3-319-69823-6>



## The 17<sup>th</sup> IEEE International Conference on Advanced Learning Technologies – ICALT 2017

July 3 – 7, 2017, eLearning Center, Timisoara, Romania

- Organizers:** IEEE Computer Society  
IEEE Technical Committee on Learning Technologies

[www.ieee-icalt.org](http://www.ieee-icalt.org), <http://icalt.elearning.upt.ro/>

The 17<sup>th</sup> IEEE International Conference on Advanced Learning Technologies (ICALT2017) was held in Timisoara, Romania.

ICALT is an annual international conference on Advanced Learning Technologies and Technology-enhanced Learning organized by the IEEE Computer Society and the IEEE Technical Committee on Learning Technology. After its kick-off as IWALT in Palmerston North, New Zealand (2000), ICALT has been held in Madison, USA (2001), Kazan, Russia (2002), Athens, Greece (2003), Joensuu, Finland (2004), Kaohsiung, Taiwan (2005), Kerkade, The Netherlands (2006), Niigata, Japan (2007), Santander, Spain (2008), Riga, Latvia (2009), Sousse, Tunisia (2010), Athens, Georgia, USA (2011), Rome, Italy (2012), Beijing, China (2013), Athens, Greece (2014), Hualien, Taiwan (2015) and Austin, Texas, USA (2016).

Publication of papers:

Conference Proceedings were published by the IEEE Computer Society Conference Publishing Services, as a volume "IEEE 17th International Conference on Advanced Learning Technologies".

ICALT 2017 received 252 papers from 53 countries. All submissions were peer-reviewed in a double-blind review process by an international panel of at least three international expert referees and decisions were taken based on assessing research quality. The quality of the submissions this year turned out to be very high. A total of 55 papers were accepted as full papers in the ICALT conference; that is a 28.40% acceptance rate. Furthermore, 85 papers were selected for presentation as short papers, 40 as posters and 7 papers were selected for the Doctoral Consortium.



## 19<sup>th</sup> Central and Eastern European NMR Symposium & Bruker Users' Meeting - CEUM 2017

September 5 - 8, 2017, Timișoara, Romania

**Organizers:** Bruker Biospin  
Politehnica University of Timisoara  
Research Institute for Renewable Energy

<http://ceum2017.upt.ro/>

The Central and Eastern European NMR Symposium and Bruker Users' Meetings is an annually symposium and in 2017 took place in Timisoara, for the second time in Romania. As previous meeting of these series, this symposium was focused on the recent progress in NMR spectroscopy, offering multiple opportunities to exchange information about novel aspects and applications of experimental NMR technique.

Over 90 Scientists from 11 European countries: Austria, Belgium, Bulgaria, Croatia, Germany, Hungary, Moldova, Poland, Portugal, Serbia and Romania participated at this meeting.

Publication of papers:

The scientific results were presented as 17 oral presentations and 32 poster presentations and 41 of them were published as abstracts in the Book of Abstracts of the Conference.



## 21<sup>st</sup> International Conference on System Theory, Control and Computing (ICSTCC 2017)

October 19 - 21, 2017, Timișoara, Romania

**Organizers:** Faculty of Automation, Computers and Electronics from University of Craiova; Faculty of Automatic Control and Computer Engineering from "Gheorghe Asachi" Technical University of Iasi; Faculty of Control Systems, Computers, Electrical and Electronics Engineering from "Dunarea de Jos" University of Galati; Faculty of Automation and Computers, Department of Automation and Applied Informatics and Department of Computers and Information Technology from Politehnica University of Timisoara

<http://www.icstcc2017.ac.tuiasi.ro/>

ICSTCC 2017 has featured several kinds of presentations, including invited talks, contributed papers, posters and special sessions. The outcome of ICSTCC 2017 is a better understanding of some leading research areas, as already System Theory, Control and Computing have demonstrated.

ICSTCC 2017 has welcomed papers on the following topics:

- Automation and Robotics: Linear and Nonlinear Control System Design, System Identification and Process Modelling, Robust and Adaptive Control, Robotics and Intelligent Control, Applications and Case Studies in Automation and Robotics, Embedded Systems;
- Computer Science and Engineering: Distributed Systems and Software Engineering, Databases, Systems of Programs and Expert Systems, Web services, Internet Security, Software Tools and Methods, Grid Computing, Artificial Intelligence, Computer Architectures;
- Electronics and Instrumentation: Modelling, Simulation and CAD Tools, Signal Processing and Communication Systems, Linear and Nonlinear Circuits and Systems, Evolutionary Electronics.

Publication of papers:

IEEE Xplore Digital Library, please visit <http://ieeexplore.ieee.org/search/searchresult.jsp?newsearch=true&queryText=ICSTCC%202017>



## SIM 2017 - 14<sup>th</sup> International Symposium on Management

“Challenges and Innovation in Management and Entrepreneurship”

October 27 - 28, 2017, Timisoara, Romania

**Organizers:** Politehnica University of Timișoara & West University of Timișoara

<http://trivent.hu/2017/sim2017/>

The 14<sup>th</sup> International Symposium on Management (SIM 2017) took place in Timisoara (Romania) between 27-28 October 2017 and ran under the topic of “Challenges and Innovation in Management and Entrepreneurship.” The SIM conference takes place every two years and is organized jointly by Timisoara’s two major universities, the Politehnica University of Timisoara and the West University of Timisoara. With over 80 participants, SIM 2017 welcomed a significant number of international participants from countries as varied as Hungary, Ecuador, France, Israel, the United States of America, Slovenia, Finland, Germany, Poland, Russia.

The four keynote speakers delighted the audience with lively presentations on challenges in educating the millennials (by Ronny Adhikarya, World Bank and ex-United Nations Representative, USA); on the leader as synergy-broker (by Gyula Bakácsi, Corvinus University, Hungary); on strategic thinking in turbulent times (by Constantin Brătianu, Bucharest University of Economic Studies, Romania); and on the use of management within a multinational company (by Samuel Cires from Heraeus Romania).

Attention was focused on, but not limited to: crisis management, management of innovation, business process management, entrepreneurship and innovation, financial management and financial governance, strategic management, organizational development and change management, logistics and supply chain, operations management, quality management, sustainable management, management in third sector organisations and social entrepreneurship, quantitative and qualitative methods in management, global management, responsible leadership.

Publication of papers:

All papers submitted to SIM go through a rigorous peer reviewing process and as a result the previous two editions of the conference, published open access by Elsevier “Procedia - Social and Behavioral Sciences”, were indexed in Thomson Reuters. The 2017 edition will also be published by Elsevier and sent for evaluation in Thomson Reuters.

# SCIENTIFIC JOURNALS





## Transactions on Hydrotechnics

Volume 62 (76), Issue 1, Issue 2 , 2017

<http://www.ct.upt.ro/buletinhidro/index.htm>

- The Scientific Bulletin of the Politehnica University of Timisoara, Transactions on Hydrotechnics is coordinated since 1992 by the Faculty of Hydrotechnical Engineering. Published papers in the journal focus on engineering sciences, civil engineering, theoretical and applied hydraulic, mathematics and numerical modeling, hydrology and water management, hydrotechnical developments and constructions, land improvement (irrigations, drainage, erosion control), engineering and sustainable rural development, water supply and sewerage systems, wastewater treatment, hydraulic structures and technologies.
- The Journal is published entirely in English, with abstracts and keywords, with international exposure.
- The revue is known for experts from home and abroad, is included in the database (Viniti, Russia) and international catalogs (SUWECO, Czech Republic). The Bulletin is broadcast in 26 foreign institutions and foreign publications received in exchange are in number of 19.



## Transactions on Mathematics and Physics

Volume 62 (76), Issue 1, 2017

[http://www.upt.ro/cercetare/mate\\_fizica.php](http://www.upt.ro/cercetare/mate_fizica.php)

- The journal "Bulletin Scientifique de l'Ecole Polytechnique de Timisoara" was founded in 1923, when the head of the Polytechnical School of Timișoara was mathematicians Victor Vâlcovici (1885-1970).
- The first two issues appeared in 1925, respectively in 1926. In the first years, the journal has been contained mostly the mathematical articles (the authors being some famous national and foreign mathematicians as well V. Alaci, G. Alexich, M. Ghermănescu, D. Pompeiu, Ch. Brunold, G. Bouligand). This fact confer to actual journal "Transactions on Mathematics and Physics" of the Scientific Bulletin of "Politehnica" University of Timisoara, Romania the justification to realize the continuity of the old "Bulletin Scientifique".
- The Transactions on Mathematics and Physics is indexed CNCIS , B+.





## Transactions on Modern Languages Volume 16, Issue 1, 2017

<http://www.cls.upt.ro/publicatii/buletinul-stiintific>

- The Transactions on Modern languages, published by the Department of Communication and Foreign Languages, has its origin in The Social Science and Humanities Series, started in 1991 under ISSN 1223-1959.
- The Transactions of Modern Languages publishes original papers in all areas of theoretical and applied linguistics: Linguistics, Translation and Interpreting Studies, Discourse Analysis, Pragmatics, Rhetoric, Terminology, LSP, Foreign Language Teaching.
- The journal is included in the CEEOL, Fabula and EBSCO data bases.

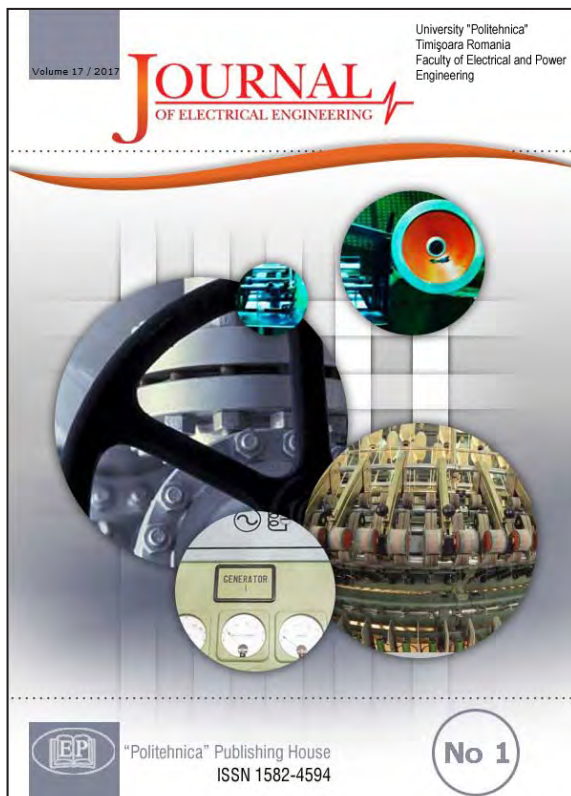

## Journal of Electrical Engineering Volume 17, Issue 1, Issue 2, Issue 3, Issue 4, 2017

<http://www.jee.ro/index.php>

- JEE continues the prestigious "Scientific Bulletin" of the Politehnica University of Timisoara, Electrotechnical section, but in electronic form.
- It also aims to become a fully international archival journal.
- Its scope includes all issues of widespread generic interest to engineers who work in the field of electrical engineering.
- The **Journal of Electrical Engineering** is indexed by Scopus and IEE INSPEC.



## Acta Technica Corviniensis - Bulletin of Engineering Volume 10, Issue 1, Issue 2, Issue 3, Issue 4, 2017

<http://acta.fih.upt.ro/>

- ACTA TECHNICA CORVINIENSIS - Bulletin of Engineering is an international and interdisciplinary journal of the Faculty of Engineering Hunedoara.
- The Journal is focused on engineering sciences and other innovative allied research areas, in all fields of science and technology on the basis of its originality, importance and timeliness.
- ACTA TECHNICA CORVINIENSIS - Bulletin of Engineering is accredited and ranked in the "B+" CATEGORY Journal by CNCIS, and is indexed by Index Copernicus, Google Scholar, EBSCO Publishing, DOAJ, SCIRUS, EVISA, ProQuest, DRJI, CAS, BASE, ULRICHswab - Global serials directory, Directory Indexing of International Research Journals, Electronic Journals Library etc.



## Annals of Faculty Engineering Hunedoara International Journal of Engineering Volume 15, Issue 1, Issue 2, Issue 3, Issue 4, 2017

<http://annals.fih.upt.ro/>

- The Journal is a multi-disciplinary journal which covers all aspects of scientific, engineering and technical disciplines including applications of scientific inventions for engineering, technological and industrial purposes, advances in engineering, technology and science.
- The Journal is accredited and ranked in the B+ category by The National University Research Council's Classification of Romanian Journals, CNCIS, and is indexed by Index Copernicus, Google Scholar, EBSCO Publishing, DOAJ, SCIRUS, EVISA, ProQuest, DRJI, CAS, BASE etc.

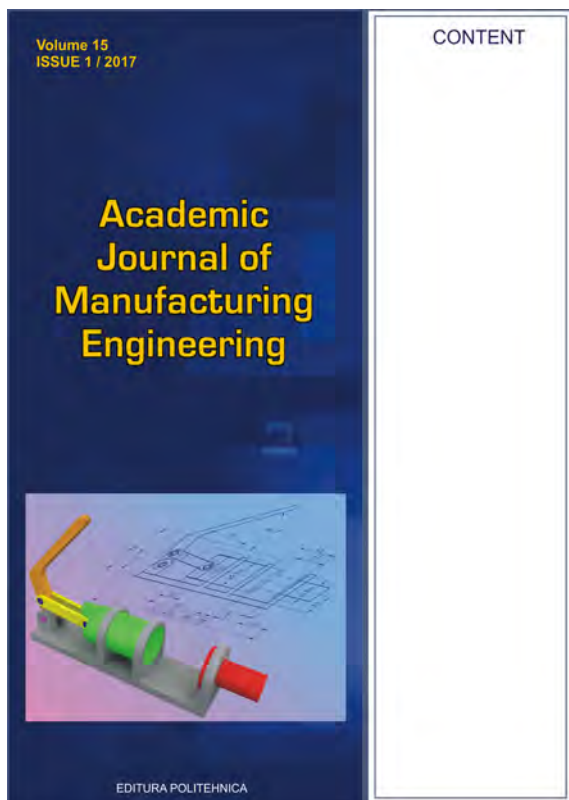

Academic Journal of Manufacturing Engineering  
Volume 15, Issue 1, Issue 2, Issue 3, Issue 4, 2017

<http://www.auif.utcluj.ro/en/>

- The Academic Journal of Manufacturing Engineering intends to provide the specialists in the manufacturing engineering field a possibility for sharing and exchanging results and information by publishing the results of their work.
- Academic Journal of Manufacturing Engineering is recognized as a B+ journal by the Romanian National Council of Scientific Research and indexed by Index Copernicus international database.

# ISI PAPERS



## EVOLUTION OF ISI PAPERS UNDER AFFILIATIONS OF PUT 2013 - 2017

Scientific writing and publication marks the endpoint of research that has been performed, completed, peer reviewed and accepted, and complements teaching and training.

In this chapter we present the publications/papers written by our professors, PhD students, researchers etc. These publications can be: papers published in ISI Journals or papers presented at Conference and indexed in ISI Proceedings.

The number of papers presented in the below figures is greater than the number of papers presented in previous Research Reports. This number varies from year to year because annually it increases the number of publications indexed in the ISI Clarivate Analytics database.

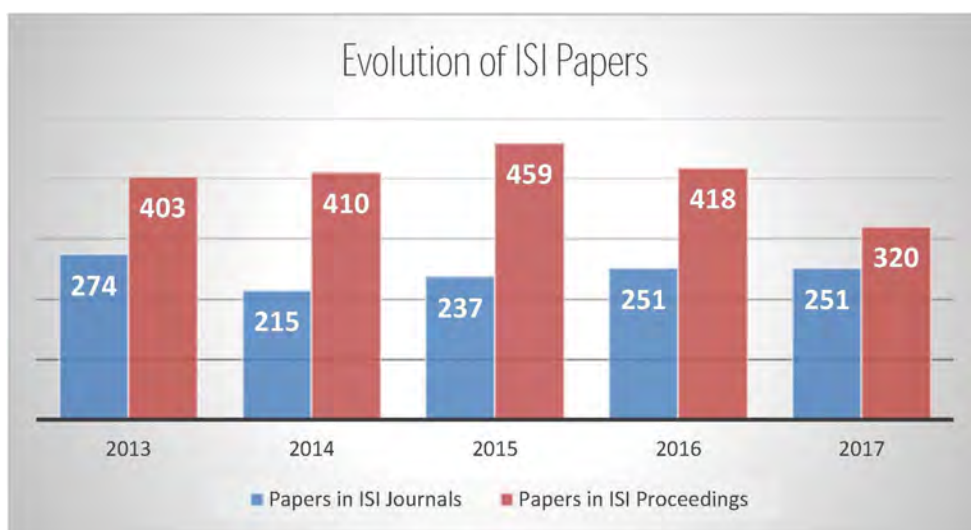
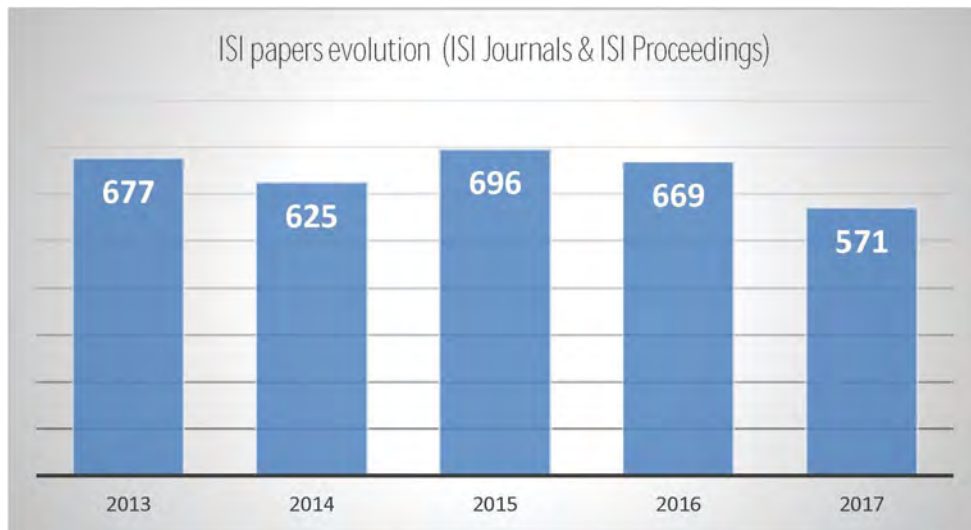

\* The data was obtained from Web of Science - Clarivate Analytics in 26 June 2018



## *ISI Papers in highlight*





## Web of Science - Clarivate Analytics Highly Cited Papers

Selected from the most recent 10 years of data, Highly Cited Papers reflect the top 1% of papers by field and publication year. Highly Cited Papers help identify breakthrough research within a research field and are used within Web of Science to identify and refine the most influential research papers.

Precup, R.E., Hellendoorn, H. A survey on industrial applications of fuzzy control, *COMPUTERS IN INDUSTRY*, Volume: 62, Issue: 3, Pages: 213-226, ISSN: 0166-3615, eISSN: 1872-6194, 2011;  
Times Cited in Web of Science Core Collection: 222



Marinca, V., Herisanu, N. Application of Optimal Homotopy Asymptotic Method for solving nonlinear equations arising in heat transfer, *INTERNATIONAL COMMUNICATIONS IN HEAT AND MASS TRANSFER*, Volume: 35, Issue: 6, Pages: 710-715, ISSN: 0735-1933, 2008;  
Times Cited in Web of Science Core Collection: 173



Marinca, V., Herisanu, N., Bota, C., Marinca, B. An optimal homotopy asymptotic method applied to the steady flow of a fourth-grade fluid past a porous plate, *APPLIED MATHEMATICS LETTERS*, Volume: 22, Issue: 2, Pages: 245-251, ISSN: 0893-9659, 2009;  
Times Cited in Web of Science Core Collection: 140



Cadariu, L., Radu, V. Fixed point methods for the generalized stability of functional equations in a single variable, *FIXED POINT THEORY AND APPLICATIONS*, Article Number: 749392, ISSN: 1687-1820, 2008;  
Times Cited in Web of Science Core Collection: 113



Sarbu, I., Sebarchievici, C. General review of ground-source heat pump systems for heating and cooling of buildings, *ENERGY AND BUILDINGS*, Volume: 70, Pages: 441-454, ISSN: 0378-7788, eISSN: 1872-6178, 2014;  
Times Cited in Web of Science Core Collection: 111



Gheju, M., Balcu, I. Removal of chromium from Cr(VI) polluted wastewaters by reduction with scrap iron and subsequent precipitation of resulted cations, *JOURNAL OF HAZARDOUS MATERIALS*, Volume: 196, Pages: 131-138, PubMed ID: 21955659, ISSN: 0304-3894, 2011.  
Times Cited in Web of Science Core Collection: 103



Highly Cited Papers received enough citations as of January/December 2017 to place them in the top 1% of their academic fields based on a highly cited threshold for the field and publication year.

\*The data was obtained from Web of Science - Clarivate Analytics in 18 May 2018

## Web of Science - Clarivate Analytics Highly Cited Paper

As of January/December 2017, this highly cited paper received enough citations to place it in the top 1% of the academic field of **Computer Science** based on a highly cited threshold for the field and publication year.

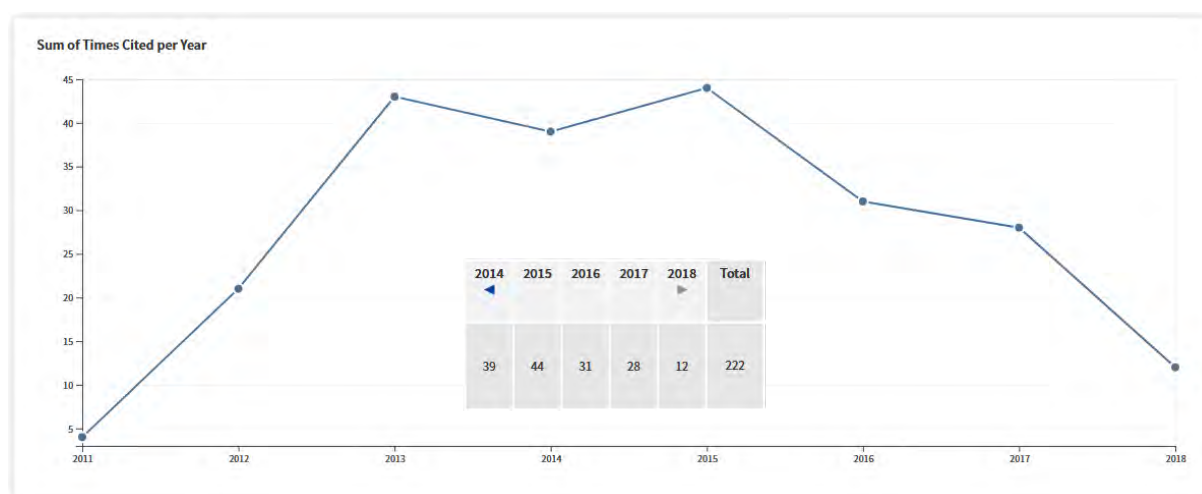

Precup, R.E., Hellendoorn, H. A survey on industrial applications of fuzzy control, *COMPUTERS IN INDUSTRY*, Volume: 62, Issue: 3, Pages: 213-226, ISSN: 0166-3615, eISSN: 1872-6194, 2011;  
Times Cited in Web of Science Core Collection: 222

**Abstract:** Fuzzy control has long been applied to industry with several important theoretical results and successful results. Originally introduced as model-free control design approach, model-based fuzzy control has gained widespread significance in the past decade.

This paper presents a survey on recent developments of analysis and design of fuzzy control systems focused on industrial applications reported after 2000.

## Web of Science - Clarivate Analytics Highly Cited Paper

As of January/December 2017, this highly cited paper received enough citations to place it in the top 1% of the academic field of **Engineering** based on a highly cited threshold for the field and publication year.

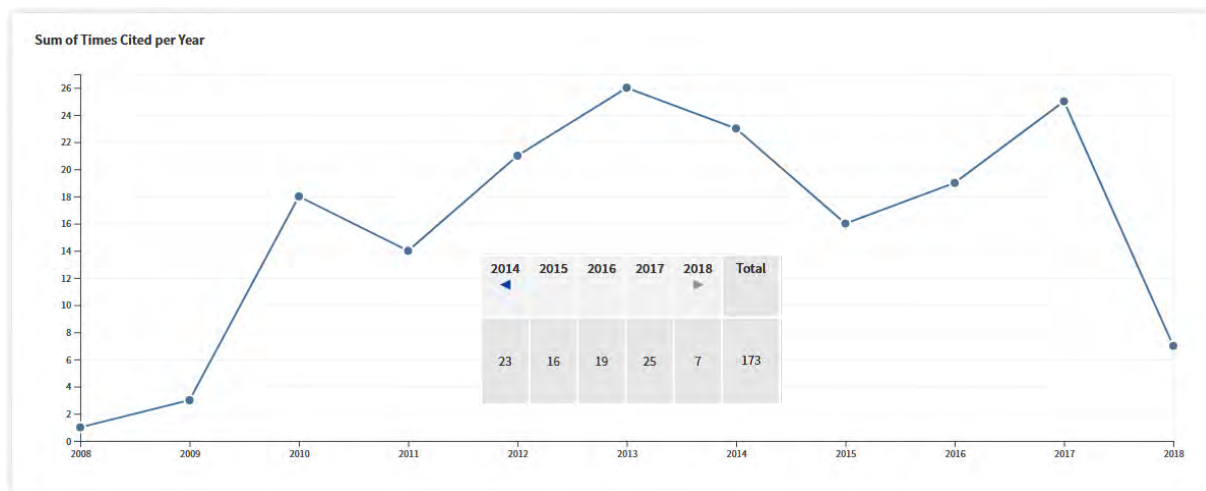

Marinca, V., Herisanu, N. Application of Optimal Homotopy Asymptotic Method for solving nonlinear equations arising in heat transfer, INTERNATIONAL COMMUNICATIONS IN HEAT AND MASS TRANSFER, Volume: 35, Issue: 6, Pages: 710-715, ISSN: 0735-1933, 2008;  
Times Cited in Web of Science Core Collection: 173

**Abstract:** We consider one of the newest analytical methods, the Optimal Homotopy Asymptotic Method (OHAM), to solve nonlinear equations arising in heat transfer. Two specific applications are considered: cooling of a lumped system with variable specific heat and the temperature distribution equation in a thick rectangular fin radiation to free space. Results obtained by OHAM, which does not need small

parameters are compared with numerical results and a very good agreement was found. This method provides us with a convenient way to control the convergence of approximation series and adjust convergence regions when necessary. The results reveal that the proposed method is explicit, effective and easy to use.

## Web of Science - Clarivate Analytics Highly Cited Paper

As of January/December 2017, this highly cited paper received enough citations to place it in the top 1% of the academic field of **Mathematics** based on a highly cited threshold for the field and publication year.

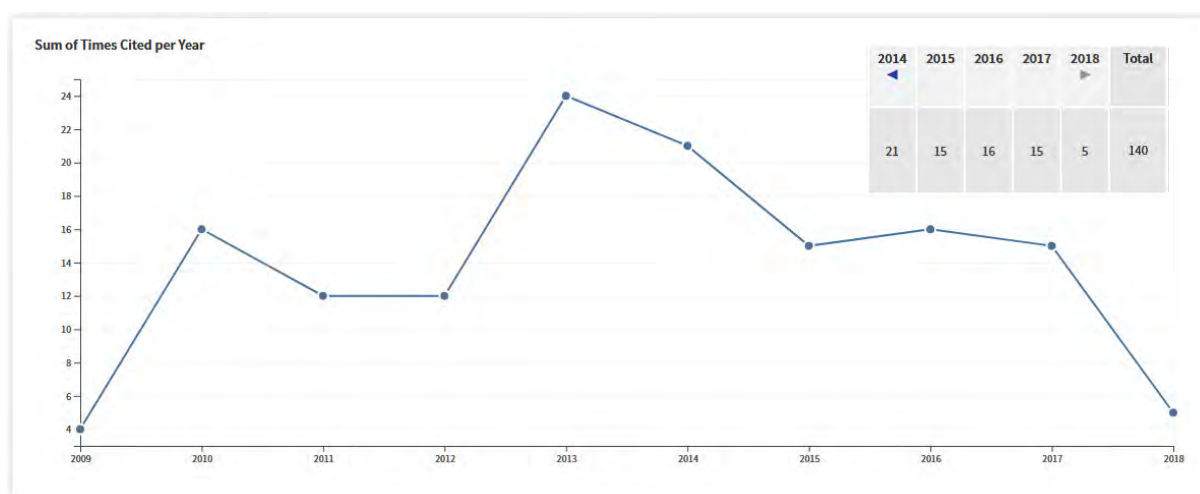

Marinca, V., Herisanu, N., Bota, C., Marinca, B. An optimal homotopy asymptotic method applied to the steady flow of a fourth-grade fluid past a porous plate, *APPLIED MATHEMATICS LETTERS*, Volume: 22, Issue: 2, Pages: 245-251, ISSN: 0893-9659, 2009;  
Times Cited in Web of Science Core Collection: 140

**Abstract:** A new analytic approximate technique for addressing non-linear problems, namely the Optimal Homotopy Asymptotic Method (OHAM), is proposed and used in an application to the steady flow of a fourth-grade fluid. This approach does not depend upon any small/large parameters. This method provides us with a convenient way to

control the convergence of approximation series and adjust convergence regions when necessary. The series solution is developed and the recurrence relations are given explicitly. The results reveal that the proposed method is effective and easy to use.

## Web of Science - Clarivate Analytics Highly Cited Paper

As of January/December 2017, this highly cited paper received enough citations to place it in the top 1% of the academic field of **Mathematics** based on a highly cited threshold for the field and publication year.

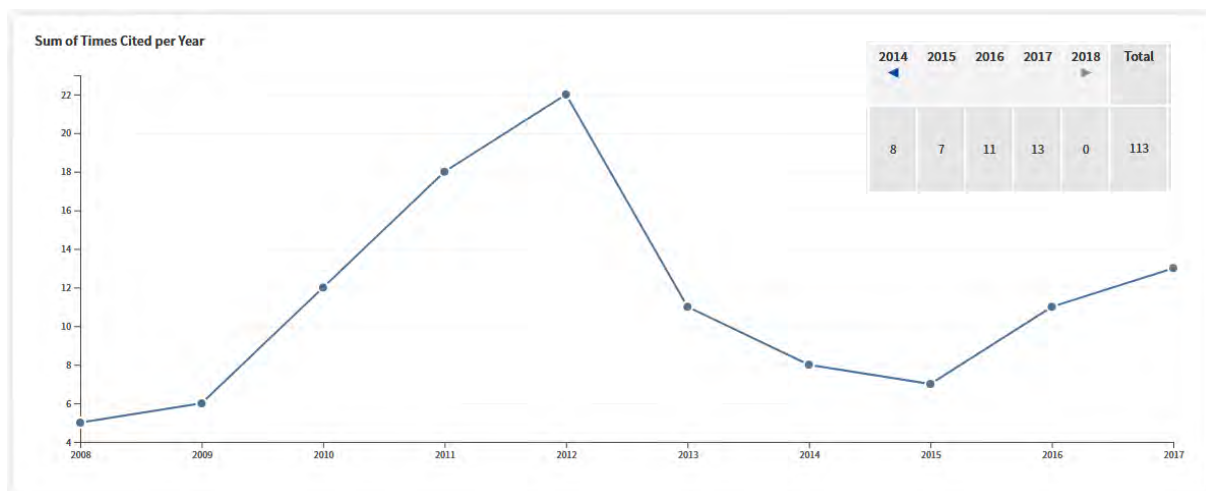

Cadariu, L., Radu, V. Fixed point methods for the generalized stability of functional equations in a single variable, *FIXED POINT THEORY AND APPLICATIONS*, Article Number: 749392, ISSN: 1687-1820, 2008;  
Times Cited in Web of Science Core Collection: 113

Abstract: We discuss on the generalized Ulam-Hyers stability for functional equations in a single variable, including the nonlinear functional equations, the linear functional equations, and a generalization of functional equation for the square root spiral. The stability results

have been obtained by a fixed point method. This method introduces a metrical context and shows that the stability is related to some fixed point of a suitable operator.

## Web of Science - Clarivate Analytics Highly Cited Paper

As of January/December 2017, this highly cited paper received enough citations to place it in the top 1% of the academic field of **Engineering** based on a highly cited threshold for the field and publication year.

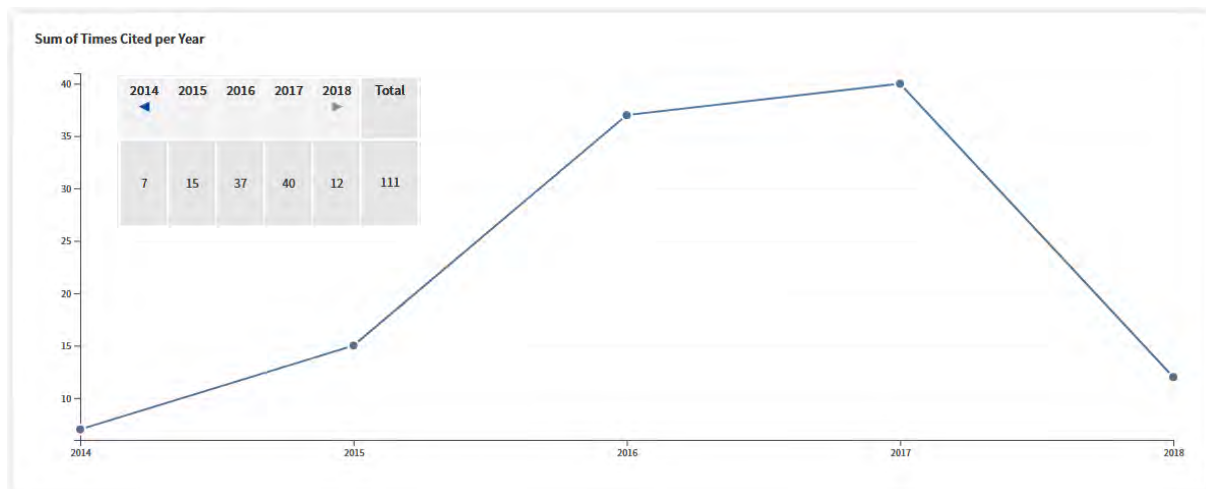

Sarbu, I., Sebarchievici, C. General review of ground-source heat pump systems for heating and cooling of buildings, *ENERGY AND BUILDINGS*, Volume: 70, Pages: 441-454, ISSN: 0378-7788, eISSN: 1872-6178, 2014;  
Times Cited in Web of Science Core Collection: 111

**Abstract:** A large number of ground-source heat pumps (GSHP) systems have been used in residential and commercial buildings throughout the world due to the attractive advantages of high energy and environmental performances. The GSHPs are proven renewable energy technology for space heating and cooling. This paper provides a detailed literature review of the GSHP systems, and their recent advances. The operation principle and energy efficiency of a heat pump are defined first. Then, a general introduction on the GSHPs and its development, and a detailed description of the surface water (SWHP), ground-water (GWHP), and ground-couplet (GCHP) heat pumps are performed. The most typical simulation and ground thermal response

test models for the vertical ground heat exchangers currently available are summarized including the heat transfer processes outside and inside the boreholes. Also, some information about a new GWHP using a heat exchanger with special construction, and the possibility to obtain the better energy efficiency with combined heating and cooling by GCHP are presented. The various hybrid GCHP systems for cooling or heating-dominated buildings are well described. Finally, the energy, economic and environmental performance of a closed-loop GCHP system is also briefly reviewed. It is found that the GSHP technology can be used both in cold and hot weather areas and the energy saving potential is significant.

## Web of Science - Clarivate Analytics Highly Cited Paper

As of January/December 2017, this highly cited paper received enough citations to place it in the top 1% of the academic field of **Engineering** based on a highly cited threshold for the field and publication year.

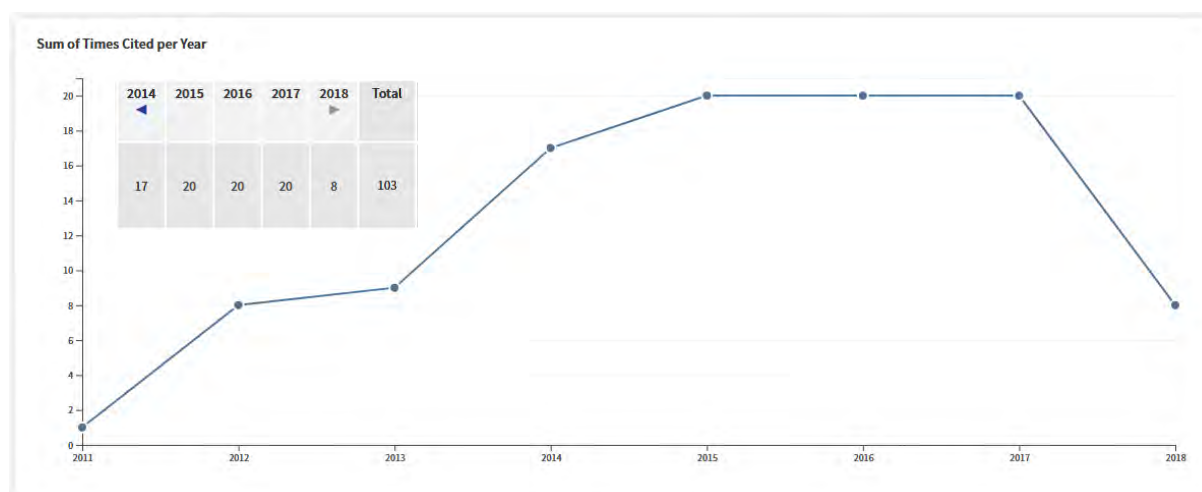

Gheju, M., Balcu, I. Removal of chromium from Cr(VI) polluted wastewaters by reduction with scrap iron and subsequent precipitation of resulted cations, *JOURNAL OF HAZARDOUS MATERIALS*, Volume: 196, Pages: 131-138, PubMed ID: 21955659, ISSN: 0304-3894, 2011;  
Times Cited in Web of Science Core Collection: 103

**Abstract:** This work presents investigations on the total removal of chromium from Cr(VI) aqueous solutions by reduction with scrap iron and subsequent precipitation of the resulted cations with NaOH. The process was detrimentally affected by a compactly passivation film occurred at scrap iron surface, mainly composed of Cr(III) and Fe(III). Maximum removal efficiency of the Cr(total) and Fe(total) achieved in the clarifier under circumneutral and alkaline (pH 9.1) conditions was 98.5% and 100%, respectively. The optimum precipitation pH range which resulted from this study is 7.6-8.0. Fe(total) and Cr(total) were

almost entirely removed in the clarifier as Fe(III) and Cr(III) species: however, after Cr(VI) breakthrough in column effluent, chromium was partially removed in the clarifier also as Cr(VI), by coprecipitation with cationic species. As long the column effluent was free of Cr(VI), the average Cr(total) removal efficiency of the packed column and clarifier was 10.8% and 78.8%, respectively. Our results clearly indicated that Cr(VI) contaminated wastewater can be successfully treated by combining reduction with scrap iron and chemical precipitation with NaOH.





No.	Article	2016 Impact Factor / Quartile in Category
1.	Abdullah, A.D., Popescu, I., Dastgheib, A., van der Zaag, P., Masih, I., Karim, U.F.A. Analysis of Possible Actions to Manage the Longitudinal Changes of Water Salinity in a Tidal River, WATER RESOURCES MANAGEMENT, Volume: 31, Issue: 7, Pages: 2157-2171, ISSN: 0920-4741, eISSN: 1573-1650, 2017;	2.848 / Q1
2.	Ancuti, C.O., Ancuti, C., De Vleeschouwer, C., Bovik, A.C. Single-Scale Fusion: An Effective Approach to Merging Images, IEEE TRANSACTIONS ON IMAGE PROCESSING, Volume: 26, Issue: 1, Pages: 65-78, PubMed ID: 27810821, ISSN: 1057-7149, eISSN: 1941-0042, 2017;	4.828 / Q1
3.	Baciu, A., Manea, F., Pop, A., Pode, R., Schoonman, L. Simultaneous voltammetric detection of ammonium and nitrite from groundwater at silver-electrodecorated carbon nanotube electrode, PROCESS SAFETY AND ENVIRONMENTAL PROTECTION, Volume: 108, Special Issue: SI, Pages: 18-25, ISSN: 0957-5820, eISSN: 1744-3598, 2017;	2.905 / Q1
4.	Baloi, M.A., Crucean, C. Fermion production by a dependent of time electric field in de Sitter universe, INTERNATIONAL JOURNAL OF MODERN PHYSICS A, Volume: 32, Issue: 36, Special Issue: SI, Article Number: 1750208, ISSN: 0217-751X, eISSN: 1793-656X, 2017	1.597 / Q2
5.	Banica, R., Ursu, D., Nyari, T., Kellenberger, A. Two step polyol-solvothermal growth of thick silver nanowires, MATERIALS LETTERS, Volume: 194, Pages: 181-184, ISSN: 0167-577X, eISSN: 1873-4979, 2017;	2.572 / Q2
6.	Beiu, R.M., Beiu, V., Duma, V.F. Fiber optic mechanical deformation sensors employing perpendicular photonic crystals, OPTICS EXPRESS, Volume: 25, Issue: 19, Pages: 23388-23398, PubMed ID: 29041640, ISSN: 1094-4087, 2017;	3.307 / Q1
7.	Belega, D., Petri, D. Effect of noise and harmonics on sine-wave frequency estimation by interpolated DFT algorithms based on few observed cycles, SIGNAL PROCESSING, Volume: 140, Pages: 207-218, ISSN: 0165-1684, eISSN: 1879-2677, 2017;	3.11 / Q1
8.	Bento, A.J.G., Lupa, N., Megan, M., Silva, C.M. INTEGRAL CONDITIONS FOR NONUNIFORM $\mu$ -DICHOTOMY ON THE HALF-LINE, DISCRETE AND CONTINUOUS DYNAMICAL SYSTEMS-SERIES B, Volume: 22, Issue: 8, Special Issue: SI, Pages: 3063-3077, ISSN: 1531-3492, eISSN: 1553-524X, 2017;	0.994 / Q2
9.	Bera, S., Sarac, B., Balakin, S., Ramasamy, P., Stoica, M., Calin, M., Eckert, J. Micro-patterning by thermoplastic forming of Ni-free Ti-based bulk metallic glasses, MATERIALS & DESIGN, Volume: 120, Pages: 204-211, ISSN: 0264-1275, eISSN: 1873-4197, 2017;	4.364 / Q1
10.	Biliuta, G., Sacarescu, L., Socoliuc, V., Iacob, M., Gheorghe, L., Negru, D., Coseri, S. Carboxylated Polysaccharides Decorated with Ultrasmall Magnetic Nanoparticles with Antibacterial and MRI Properties, MACROMOLECULAR CHEMISTRY AND PHYSICS, Volume: 218, Issue: 10, Article Number: 1700062, ISSN: 1022-1352, eISSN: 1521-3935, 2017;	2.5 / Q2
11.	Binzar, T., Lazureanu, C. On the Wold-Type Decompositions for n-Tuples of Commuting Isometric Semigroups, FILOMAT, Volume: 31, Issue: 5, Pages: 1251-1264, ISSN: 0354-5180, 2017;	0.695 / Q2
12.	Bistrrian, D.A., Navon, I.M. The method of dynamic mode decomposition in shallow water and a swirling flow problem, INTERNATIONAL JOURNAL FOR NUMERICAL METHODS IN FLUIDS, Volume: 83, Issue: 1, Pages: 73-89, ISSN: 0271-2091, eISSN: 1097-0363, 2017;	1.652 / Q2
13.	Bistrrian, D.A., Navon, I.M. Randomized dynamic mode decomposition for nonintrusive reduced order modelling, INTERNATIONAL JOURNAL FOR NUMERICAL METHODS IN ENGINEERING, Volume: 112, Issue: 1, Pages: 3-25, ISSN: 0029-5981, eISSN: 1097-0207, 2017;	2.162 / Q1

No.	Article	2016 Impact Factor / Quartile in Category
14.	Bota, C., Caruntu, B., Lazureanu, C. THE LEAST SQUARE HOMOTOPY PERTURBATION METHOD FOR BOUNDARY VALUE PROBLEMS, APPLIED AND COMPUTATIONAL MATHEMATICS, Volume: 16, Issue: 1, Pages: 39-47, ISSN: 1683-3511, eISSN: 1683-6154, 2017;	1.333 / Q2
15.	Bota, C., Caruntu, B. Analytical approximate solutions for quadratic Riccati differential equation of fractional order using the Polynomial Least Squares Method, CHAOS SOLITONS & FRACTALS, Volume: 102, Pages: 339-345, ISSN: 0960-0779, eISSN: 1873-2887, 2017;	1.455 / Q2
16.	Bota, C., Caruntu, B. ANALYTIC APPROXIMATE SOLUTIONS FOR A CLASS OF VARIABLE ORDER FRACTIONAL DIFFERENTIAL EQUATIONS USING THE POLYNOMIAL LEAST SQUARES METHOD, FRACTIONAL CALCULUS AND APPLIED ANALYSIS, Volume: 20, Issue: 4, Pages: 1043-1050, ISSN: 1311-0454, eISSN: 1314-2224, 2017;	2.034 / Q1
17.	Bota, C., Caruntu, B. Approximate analytical solutions of nonlinear differential equations using the Least Squares Homotopy Perturbation Method, JOURNAL OF MATHEMATICAL ANALYSIS AND APPLICATIONS, Volume: 448, Issue: 1, Pages: 401-408, ISSN: 0022-247X, eISSN: 1096-0813, 2017;	1.064 / Q1
18.	Bota, C. The approximation of solutions for second order nonlinear oscillators using the polynomial least square method, JOURNAL OF NONLINEAR SCIENCES AND APPLICATIONS, Volume: 10, Issue: 1, Pages: 234-242, ISSN: 2008-1898, eISSN: 2008-1901, 2017;	1.34 / Q1
19.	Casu, I., Lazureanu, C. Stability and Integrability Aspects for the Maxwell - Bloch Equations with the Rotating Wave Approximation, REGULAR & CHAOTIC DYNAMICS, Volume: 22, Issue: 2, Pages: 109-121, ISSN: 1560-3547, eISSN: 1468-4845, 2017;	1.562 / Q1
20.	Cebucean, D., Cebucean, V., Ionel, I., Spliethoff, H. Performance of two iron-based syngas-fueled chemical looping systems for hydrogen and/or electricity generation combined with carbon capture, CLEAN TECHNOLOGIES AND ENVIRONMENTAL POLICY, Volume: 19, Issue: 2, Pages: 451-470, ISSN: 1618-954X, eISSN: 1618-9558, 2017;	3.331 / Q2
21.	Cioabla, A.E., Pop, N., Trif-Tordai, G., Calinoiu, D.G. Comparative analysis of agricultural materials influenced by anaerobic fermentation for biogas production in terms of ash melting behavior, JOURNAL OF THERMAL ANALYSIS AND CALORIMETRY, Volume: 127, Issue: 1, Pages: 515-523, ISSN: 1388-6150, eISSN: 1588-2926, 2017;	1.953 / Q2
22.	Cioca, L.I., Ivascu, L. Risk Indicators and Road Accident Analysis for the Period 2012-2016, SUSTAINABILITY, Volume: 9, Issue: 9, Article Number: 1530, ISSN: 2071-1050, 2017;	1.789 / Q2
23.	Cioca, M., Ivascu, L., Cioca, L.I. SAFETY PERFORMANCE INDICATORS IN THE METALLURGICAL INDUSTRY USING WEB PROGRAMMING, METALURGIJA, Volume: 56, Issue: 1-2, Pages: 272-274, ISSN: 0543-5846, eISSN: 1334-2576, 2017;	0.959 / Q2
24.	Coricovac, D.E., Moaca, E.A., Pinzaru, I., Citu, C., Soica, C., Mihali, C.V., Pacurariu, C., Tutelyan, V.A., Tsatsakis, A., Dehelean, C.A. Biocompatible Colloidal Suspensions Based on Magnetic Iron Oxide Nanoparticles: Synthesis, Characterization and Toxicological Profile, FRONTIERS IN PHARMACOLOGY Volume: 8 Article Number: UNSP 154, PubMed ID: 28400730, ISSN: 1663-9812, 2017;	4.4 / Q1
25.	Cornea, O., Andreescu, G.D., Muntean, N., Hulea, D. Bidirectional Power Flow Control in a DC Microgrid Through a Switched-Capacitor Cell Hybrid DC-DC Converter, IEEE TRANSACTIONS ON INDUSTRIAL ELECTRONICS, Volume: 64, Issue: 4, Pages: 3012-3022, ISSN: 0278-0046, eISSN: 1557-9948, 2017;	7.168 / Q1
26.	Craciunescu, I., Petran, A., Liebscher, J., Vekas, L., Turcu, R. Synthesis and characterization of size-controlled magnetic clusters functionalized with polymer layer for wastewater depollution, MATERIALS CHEMISTRY AND PHYSICS, Volume: 185, Pages: 91-97, ISSN: 0254-0584, eISSN: 1879-3312, 2017;	2.084 / Q2

No.	Article	2016 Impact Factor / Quartile in Category
27.	Dinu, F., Marginean, I., Dubina, D. Experimental testing and numerical modelling of steel moment-frame connections under column loss, ENGINEERING STRUCTURES, Volume: 151, Pages: 861-878, ISSN: 0141-0296, eISSN: 1873-7323, 2017;	2.258 / Q1
28.	Dogariu, A.I., Dubina, D. STRENGTHENING OF MASONRY SHEAR WALLS BASED ON METAL SOLUTIONS. PART II: FE-MODEL FOR THE PERFORMANCE EVALUATION, PROCEEDINGS OF THE ROMANIAN ACADEMY SERIES A-MATHEMATICS PHYSICS TECHNICAL SCIENCES INFORMATION SCIENCE, Volume: 18, Issue: 2, Pages: 158-165, ISSN: 1454-9069, 2017;	1.623 / Q2
29.	Dogariu, A.I., Dubina, D. STRENGTHENING OF MASONRY SHEAR WALLS BASED ON METAL SOLUTIONS. PART I: EXPERIMENTAL INVESTIGATION, PROCEEDINGS OF THE ROMANIAN ACADEMY SERIES A-MATHEMATICS PHYSICS TECHNICAL SCIENCES INFORMATION SCIENCE, Volume: 18, Issue: 1, Pages: 81-88, ISSN: 1454-9069, 2017;	1.623 / Q2
30.	Duma, V.F. POLYGONAL MIRROR LASER SCANNING HEADS: CHARACTERISTIC FUNCTIONS, PROCEEDINGS OF THE ROMANIAN ACADEMY SERIES A-MATHEMATICS PHYSICS TECHNICAL SCIENCES INFORMATION SCIENCE, Volume: 18, Issue: 1, Pages: 25-33, ISSN: 1454-9069, 2017;	1.623 / Q2
31.	Dumitru, R., Manea, F., Lupa, L., Pacurariu, C., Ianculescu, A., Baciu, A., Negrea, S. Synthesis, characterization of nanosized CoAl <sub>2</sub> O <sub>4</sub> and its electrocatalytic activity for enhanced sensing application, JOURNAL OF THERMAL ANALYSIS AND CALORIMETRY, Volume: 128, Issue: 3, Pages: 1305-1312, ISSN: 1388-6150, eISSN: 1588-2926, 2017;	1.953 / Q2
32.	Elfimova, E.A., Ivanov, A.O., Popescu, L.B., Socoliuc, V. Transverse magneto-optical anisotropy in bidisperse ferrofluids with long range particle correlations, JOURNAL OF MAGNETISM AND MAGNETIC MATERIALS, Volume: 431, Pages: 54-58, ISSN: 0304-8853, eISSN: 1873-4766, 2017;	2.63 / Q2
33.	Fagadar-Cosma, E., Badea, V., Fagadar-Cosma, G., Palade, A., Lascu, A., Fringu, I., Birdeanu, M. Trace Oxygen Sensitive Material Based on Two Porphyrin Derivatives in a Heterodimeric Complex, MOLECULES, Volume: 22, Issue: 10, Article Number: 1787, ISSN: 1420-3049, 2017;	2.861 / Q2
34.	Feniser, C., Burz, G., Mocan, M., Ivascu, L., Gherhes, V., Otel, C.C. The Evaluation and Application of the TRIZ Method for Increasing Eco-Innovative Levels in SMEs, SUSTAINABILITY, Volume: 9, Issue: 7, Article Number: 1125, ISSN: 2071-1050, 2017;	1.789 / Q2
35.	Filip, I., Szeidert, I. Tuning the control penalty factor of a minimum variance adaptive controller, EUROPEAN JOURNAL OF CONTROL, Volume: 37, Pages: 16-26, ISSN: 0947-3580, eISSN: 1435-5671, 2017;	1.944 / Q2
36.	Filip-Vacarescu, N., Vulcu, C., Dubina, D. NUMERICAL STUDY OF A HYBRID DAMPING SYSTEM COMPOSED OF A BUCKLING RESTRAINED BRACE WITH A MAGNETO RHEOLOGICAL DAMPER, PROCEEDINGS OF THE ROMANIAN ACADEMY SERIES A-MATHEMATICS PHYSICS TECHNICAL SCIENCES INFORMATION SCIENCE, Volume: 18, Issue: 3, Pages: 273-280, ISSN: 1454-9069, 2017;	1.623 / Q2
37.	Filippov, S.N., Magadov, K.Y., Jivulescu, M.A. Absolutely separating quantum maps and channels, NEW JOURNAL OF PHYSICS, Volume: 19, Article Number: 083010, ISSN: 1367-2630, 2017;	3.786 / Q1
38.	Foroughi, A., Ashuri, H., Tavakoli, R., Stoica, M., Sopa, D., Eckert, J. Structural modification through pressurized sub-T-g annealing of metallic glasses, JOURNAL OF APPLIED PHYSICS, Volume: 122, Issue: 21, Article Number: 215106, ISSN: 0021-8979, eISSN: 1089-7550, 2017;	2.068 / Q2
39.	Frandes, M., Deiac, A.V., Timar, B., Lungeanu, D. Instrument for assessing mobile technology acceptability in diabetes self-management: a validation and reliability study, PATIENT PREFERENCE AND ADHERENCE, Volume: 11, Pages: 259-269, PubMed ID: 28243069, ISSN: 1177-889X, 2017;	1.798 / Q2

No.	Article	2016 Impact Factor / Quartile in Category
40.	Gabor, A., Davidescu, C.M., Negrea, A., Ciopec, M., Grozav, I., Negrea, P., Duteanu, N. Optimizing the lanthanum adsorption process onto chemically modified biomaterials using factorial and response surface design, JOURNAL OF ENVIRONMENTAL MANAGEMENT, Volume: 204, Special Issue: SI, Pages: 839-844, PubMed ID: 28148453, ISSN: 0301-4797, eISSN: 1095-8630, 2017;	4.01 / Q1
41.	Gabor, A., Davidescu, C.M., Negrea, A., Ciopec, M., Muntean, C., Negrea, P., Ianasi, C., Butnariu, M. Magnesium silicate doped with environmentally friendly extractants used for rare earth elements adsorption, DESALINATION AND WATER TREATMENT, Volume: 63, Pages: 124-134, ISSN: 1944-3994, eISSN: 1944-3986, 2017;	1.631 / Q2
42.	Gheju, M., Balcu, I. Assisted green remediation of chromium pollution, JOURNAL OF ENVIRONMENTAL MANAGEMENT, Volume: 203, Special Issue: SI, Pages: 920-924, Part: 3, PubMed ID: 28479231, ISSN: 0301-4797, eISSN: 1095-8630, 2017;	4.01 / Q1
43.	Gheju, M., Balcu, I., Enache, A., Flueraș, A. A kinetic approach on hexavalent chromium removal with metallic iron, JOURNAL OF ENVIRONMENTAL MANAGEMENT, Volume: 203, Special Issue: SI, Pages: 937-941, Part: 3, PubMed ID: 28318824, ISSN: 0301-4797, eISSN: 1095-8630, 2017;	4.01 / Q1
44.	Grigorie, A.C., Muntean, C., Vlase, T., Locovei, C., Stefanescu, M. ZnO-SiO <sub>2</sub> based nanocomposites prepared by a modified sol-gel method, MATERIALS CHEMISTRY AND PHYSICS, Volume: 186, Pages: 399-406, ISSN: 0254-0584, eISSN: 1879-3312, 2017;	2.084 / Q2
45.	Hadaruga, D.I., Birau, C.L., Gruia, A.T., Paunescu, V., Bandur, G.N., Hadaruga, N.G. Moisture evaluation of beta-cyclodextrin/fish oils complexes by thermal analyses: A data review on common barbel ( <i>Barbus barbus</i> L.), Pontic shad ( <i>Alosa immaculata</i> Bennett), European wels catfish ( <i>Silurus glanis</i> L.), and common bleak ( <i>Alburnus alburnus</i> L.) living in Danube river, FOOD CHEMISTRY, Volume: 236, Pages: 49-58, PubMed ID: 28624089, ISSN: 0308-8146, eISSN: 1873-7072, 2017;	4.529 / Q1
46.	Herban, I.S., Vilceanu, C.B., Grecea, C. Road-Structure Monitoring with Modern Geodetic Technologies, JOURNAL OF SURVEYING ENGINEERING, Volume: 143, Issue: 4, Article Number: 05017004, ISSN: 0733-9453, eISSN: 1943-5428, 2017;	1.667 / Q2
47.	Ianos, R., Babuta, R., Pacurariu, C., Lazau, R., Istratie, R., Butaciu, C. Combustion synthesis of ZnAl <sub>2</sub> O <sub>4</sub> powders with tuned surface area, CERAMICS INTERNATIONAL, Volume: 43, Issue: 12, Pages: 8975-8981, ISSN: 0272-8842, eISSN: 1873-3956, 2017;	2.986 / Q1
48.	Ianos, R., Muntean, E., Pacurariu, C., Lazau, R., Bendas, C., Delinescu, G. Combustion synthesis of a blue Co-doped zinc aluminate near-infrared reflective pigment, DYES AND PIGMENTS, Volume: 142, Pages: 24-31, ISSN: 0143-7208, eISSN: 1873-3743, 2017;	3.473 / Q1
49.	Ianos, R., Muntean, E., Babuta, R., Lazau, R., Pacurariu, C., Bendas, C. Combustion synthesis of pink chromium-doped alumina with excellent near-infrared reflective properties, CERAMICS INTERNATIONAL, Volume: 43, Issue: 2, Pages: 2568-2572, ISSN: 0272-8842, eISSN: 1873-3956, 2017;	2.986 / Q1
50.	Iliă, R., Liatsou, I., Savva, I., Vasile, E., Vekas, L., Marinica, O., Mpekris, F., Pashalidis, I., Krasia-Christoforou, T. Magneto-responsive polymer networks as adsorbents for the removal of U (VI) ions from aqueous media, EUROPEAN POLYMER JOURNAL, Volume: 97, Pages: 138-146, ISSN: 0014-3057, eISSN: 1873-1945, 2017;	3.531 / Q1
51.	Ionescu, D., Kovaci, M. IMPROVING THE DATA STORAGE PERFORMANCES WITH LAYERED NANOWIRES FOR SYNTHETIC ANTIFERROMAGNETIC RACETRACK MEMORIES, ROMANIAN REPORTS IN PHYSICS, Volume: 69, Issue: 1, Article Number: 501, ISSN: 1221-1451, eISSN: 1841-8759, 2017;	1.467 / Q2

No.	Article	2016 Impact Factor / Quartile in Category
52.	Istratie, R., Babuta, R., Popa, A., Pacurariu, C., Stoia, M. Enhanced Adsorption of p-Nitrophenol from Aqueous Solutions Using a Functionalized Styrene-Divinylbenzene Copolymer, WATER AIR AND SOIL POLLUTION, Volume: 228, Issue: 8, Article Number: 276, ISSN: 0049-6979, eISSN: 1573-2932, 2017;	1.702 / Q2
53.	Jivulescu, M.A., Nechita, I., Gavruta, P. On symmetric decompositions of positive operators, JOURNAL OF PHYSICS A-MATHEMATICAL AND THEORETICAL Volume: 50 Issue: 16 Article Number: 165303, ISSN: 1751-8113, eISSN: 1751-8121, 2017;	1.865 / Q1
54.	Lascu, C., Jafarzadeh, S., Fadali, M.S., Blaabjerg, F. Direct Torque Control With Feedback Linearization for Induction Motor Drives, IEEE TRANSACTIONS ON POWER ELECTRONICS, Volume: 32, Issue: 3, Pages: 2072-2080, ISSN: 0885-8993, eISSN: 1941-0107, 2017;	7.151 / Q1
55.	Lazureanu, C. The Real-Valued Maxwell-Bloch Equations with Controls: From a Hamilton-Poisson System to a Chaotic One, INTERNATIONAL JOURNAL OF BIFURCATION AND CHAOS, Volume: 27, Issue: 9, Article Number: 1750143, ISSN: 0218-1274, eISSN: 1793-6551, 2017;	1.329 / Q2
56.	Linul, E., Serban, D.A., Marsavina, L., Kovacik, J. Low-cycle fatigue behaviour of ductile closed-cell aluminium alloy foam, FATIGUE & FRACTURE OF ENGINEERING MATERIALS & STRUCTURES, Volume: 40, Issue: 4, Pages: 597-604, ISSN: 8756-758X, eISSN: 1460-2695, 2017;	2.335 / Q1
57.	Linul, E., Movahedi, N., Marsavina, L. The temperature effect on the axial quasi-static compressive behavior of ex-situ aluminum foam-filled tubes, COMPOSITE STRUCTURES, Volume: 180, Pages: 709-722, ISSN: 0263-8223, eISSN: 1879-1085, 2017;	3.858 / Q1
58.	Linul, E., Marsavina, L., Kovacik, J., Sadowski, T. DYNAMIC AND QUASI-STATIC COMPRESSION TESTS OF CLOSED-CELL ALUMINIUM ALLOY FOAMS, PROCEEDINGS OF THE ROMANIAN ACADEMY SERIES A-MATHEMATICS PHYSICS TECHNICAL SCIENCES INFORMATION SCIENCE, Volume: 18, Issue: 4, Pages: 361-369, ISSN: 1454-9069, 2017;	1.623 / Q2
59.	Linul, E., Serban, D.A., Marsavina, L., Sadowski, T. Assessment of collapse diagrams of rigid polyurethane foams under dynamic loading conditions, ARCHIVES OF CIVIL AND MECHANICAL ENGINEERING, Volume: 17, Issue: 3, Pages: 457-466, ISSN: 1644-9665, eISSN: 2083-3318, 2017;	2.216 / Q1
60.	Linul, E., Marsavina, L., Kovacik, J. Collapse mechanisms of metal foam matrix composites under static and dynamic loading conditions, MATERIALS SCIENCE AND ENGINEERING A-STRUCTURAL MATERIALS PROPERTIES MICROSTRUCTURE AND PROCESSING, Volume: 690, Pages: 214-224, ISSN: 0921-5093, eISSN: 1873-4936, 2017;	3.094 / Q1
61.	Lovasz, E.C., Margineanu, D.T., Ciupe, V., Maniu, I., Gruescu, C.M., Zabava, E.S., Stan, S.D. Design and control solutions for haptic elbow exoskeleton module used in space telerobotics, MECHANISM AND MACHINE THEORY, Volume: 107, Pages: 384-398, ISSN: 0094-114X, 2017;	2.577 / Q1
62.	Lupa, L., Popa, A., Dragan, E.S., Ciopec, M., Negrea, A., Negrea, P. Adsorption performance of the organic solid support impregnated with ionic liquid in the removal process of T1(1) from aqueous solutions, PROCESS SAFETY AND ENVIRONMENTAL PROTECTION, Volume: 108, Special Issue: SI, Pages: 67-73, ISSN: 0957-5820, eISSN: 1744-3598, 2017;	2.905 / Q1
63.	Madescu, G., Biriescu, M., Tutelea, L.N., Mot, M., Svoboda, M., Boldea, I. Experimental Investigation of Rotor Currents Distribution in the Healthy and Faulty Cage of Induction Motors at Standstill, IEEE TRANSACTIONS ON INDUSTRIAL ELECTRONICS, Volume: 64, Issue: 7, Pages: 5305-5313, ISSN: 0278-0046, eISSN: 1557-9948, 2017;	7.168 / Q1
64.	Maierean, S.M., Serban, M.C., Sahebkar, A., Ursoniu, S., Serban, A., Penson, P., Banach, M. The effects of cinnamon supplementation on blood lipid concentrations: A systematic review and meta-analysis, JOURNAL OF CLINICAL LIPIDOLOGY, Volume: 11, Issue: 6, Pages: 1393-1406, PubMed ID: 28887086, ISSN: 1933-2874, eISSN: 1876-4789, 2017;	5.812 / Q1

No.	Article	2016 Impact Factor / Quartile in Category
65.	Marinca, B., Marinca, V. NEW EXACT AND EXPLICIT SOLUTIONS OF THE ZAKHAROV EQUATIONS AND GENERALIZED ZAKHAROV EQUATIONS BY THE QUOTIENT TRIGONOMETRIC FUNCTION EXPANSION METHOD, PROCEEDINGS OF THE ROMANIAN ACADEMY SERIES A-MATHEMATICS PHYSICS TECHNICAL SCIENCES INFORMATION SCIENCE, Volume: 18, Issue: 2, Pages: 166-173, ISSN: 1454-9069, 2017;	1.623 / Q2
66.	Marinica, O.M. Study of Static Magnetic Properties of Transformer Oil Based Magnetic Fluids for Various Technical Applications Using Demagnetizing Field Correction, JOURNAL OF NANOMATERIALS, Article Number: 5407679, ISSN: 1687-4110, eISSN: 1687-4129, 2017;	1.871 / Q2
67.	Marsavina, L., Berto, F., Negru, R., Serban, D.A., Linul, E. An engineering approach to predict mixed mode fracture of PUR foams based on ASED and micromechanical modelling, THEORETICAL AND APPLIED FRACTURE MECHANICS, Volume: 91, Special Issue: SI, Pages: 148-154, ISSN: 0167-8442, eISSN: 1872-7638, 2017;	2.659 / Q1
68.	Martian, V., Albetel, S., David, E., Nagi, M. Heat transfer and hydraulic performance models for a family of aluminum plate heat exchanger with transversal offset strip fins, EXPERIMENTAL HEAT TRANSFER, Volume: 30, Issue: 6, Pages: 530-543, ISSN: 0891-6152, eISSN: 1521-0480, 2017;	1.522 / Q2
69.	Mazilescu, C.A., Gangloff, B. Value Assigned to Employees Who Preserve the Social and Organizational Environment, SUSTAINABILITY, Volume: 9, Issue: 2, Article Number: 170, ISSN: 2071-1050, 2017;	1.789 / Q2
70.	Melita, N.T., Holban, S. dGAsellID: An R Package for Selecting a Variable Number of Features in High Dimensional Data, R JOURNAL, Volume: 9, Issue: 2, Pages: 18-34, ISSN: 2073-4859, 2017;	1.075 / Q2
71.	Micea, M.V., Stangaciu, C.S., Stangaciu, V., Curiac, D.I. Novel Hybrid Scheduling Technique for Sensor Nodes with Mixed Criticality Tasks, SENSORS, Volume: 17, Issue: 7, Article Number: 1504, ISSN: 1424-8220, 2017;	2.677 / Q1
72.	Mihaicuta, S., Udrescu, M., Topirceanu, A., Udrescu, L. Network science meets respiratory medicine for OSAS phenotyping and severity prediction, PEERJ, Volume: 5, Article Number: e3289, PubMed ID: 28503375, ISSN: 2167-8359, 2017;	2.177 / Q2
73.	Mnerie, C., Preitl, S., Duma, V.F. Galvanometer-Based Scanners: Mathematical Model and Alternative Control Structures for Improved Dynamics and Immunity to Disturbances, INTERNATIONAL JOURNAL OF STRUCTURAL STABILITY AND DYNAMICS, Volume: 17, Issue: 5, Special Issue: SI, Article Number: 1740006, ISSN: 0219-4554, eISSN: 1793-6764, 2017;	1.617 / Q2
74.	Moisa, M.E., Spelmezan, C.G., Paul, C., Bartha-Vari, J.H., Bencz, L.C., Irimie, F.D., Paizs, C., Peter, F., Tosa, M.I. Tailored sol-gel immobilized lipase preparates for the enzymatic kinetic resolution of heteroaromatic alcohols in batch and continuous flow systems, RSC ADVANCES, Volume: 7, Issue: 83, Pages: 52977-52987, ISSN: 2046-2069, 2017;	3.108 / Q2
75.	Moro, A.J., Parola, A.J., Pina, F., Pana, A.M., Badea, V., Pausescu, I., Shova, S., Cseh, L. 2,2'-Spirobis[chromene] Derivatives Chemistry and Their Relation with the Multistate System of Anthocyanins, JOURNAL OF ORGANIC CHEMISTRY, Volume: 82, Issue: 10, Pages: 5301-5309, PubMed ID: 28441475, ISSN: 0022-3263, 2017;	4.849 / Q1
76.	Mosoarca, M., Keller, A.I., Petrus, C., Racolta, A. Failure analysis of historical buildings due to climate change, ENGINEERING FAILURE ANALYSIS, Volume: 82, Pages: 666-680, ISSN: 1350-6307, eISSN: 1873-1961, 2017;	1.676 / Q2
77.	Movahedi, N., Linul, E. Quasi-static compressive behavior of the ex-situ aluminum-alloy foam-filled tubes under elevated temperature conditions, MATERIALS LETTERS, Volume: 206, Pages: 182-184, ISSN: 0167-577X, eISSN: 1873-4979, 2017;	2.572 / Q2



No.	Article	2016 Impact Factor / Quartile in Category
78.	Nagy, Z., Gilia, L., Neagu, C. EXPERIMENTAL INVESTIGATIONS OF COLD-FORMED JOINTS FOR MULTI-STOREY STEEL FRAMED STRUCTURES, PROCEEDINGS OF THE ROMANIAN ACADEMY SERIES A-MATHEMATICS PHYSICS TECHNICAL SCIENCES INFORMATION SCIENCE, Volume: 18, Issue: 3, Pages: 256-264, ISSN: 1454-9069, 2017;	1.623 / Q2
79.	Nani, V.M. Complex phenomena study in dielectric fluid from gap during the W-EDM processing in ultrasonic field, INTERNATIONAL JOURNAL OF ADVANCED MANUFACTURING TECHNOLOGY, Volume: 92, Issue: 1-4, Pages: 197-215, ISSN: 0268-3768, eISSN: 1433-3015, 2017;	2.209 / Q2
80.	Nani, V.M. Effect of wire electrode's ultrasonic vibration on erosive capacity to W-EDM machine, INTERNATIONAL JOURNAL OF ADVANCED MANUFACTURING TECHNOLOGY, Volume: 88, Issue: 1-4, Pages: 425-441, ISSN: 0268-3768, eISSN: 1433-3015, 2017;	2.209 / Q2
81.	Nani, V.M. The ultrasound effect on technological parameters for increase in performances of W-EDM machines, INTERNATIONAL JOURNAL OF ADVANCED MANUFACTURING TECHNOLOGY, Volume: 88, Issue: 1-4, Pages: 519-528, ISSN: 0268-3768, eISSN: 1433-3015, 2017;	2.209 / Q2
82.	Nani, V.M. Ultrasound influence on the erosive capacity at the electrodischarge processing with ultrasonic activated wire electrode in a single point, MECCANICA, Volume: 52, Issue: 6, Pages: 1459-1474, ISSN: 0025-6455, eISSN: 1572-9648, 2017;	2.196 / Q2
83.	Nani, V.M., Cires, I. The vibrations' study to the burn gas exhaust fan from a thermoelectric power plant, APPLIED MATHEMATICAL MODELLING, Volume: 43, Pages: 454-463, ISSN: 0307-904X, eISSN: 1872-8480, 2017;	2.35 / Q1
84.	Nanu, S., Ionel, R., Dughir, C., Ionel, I. Automation of a prototype for cutting, sorting and bundling of SRC crops for planting purposes, MEASUREMENT, Volume: 95, Pages: 201-209, ISSN: 0263-2241, eISSN: 1873-412X, 2017;	2.359 / Q1
85.	Nicoara, M., Raduta, A., Locovei, C., Buzdugan, D., Stoica, M. About thermostability of biocompatible Ti-Zr-Ta-Si amorphous alloys, JOURNAL OF THERMAL ANALYSIS AND CALORIMETRY, Volume: 127, Issue: 1, Pages: 107-113, ISSN: 1388-6150, eISSN: 1588-2926, 2017;	1.953 / Q2
86.	Nicoara, M., Locovei, C., Opris, C., Ursu, D., Vasiu, R., Stoica, M. Optimizing the parameters for in situ fabrication of hybrid Al-Al <sub>2</sub> O <sub>3</sub> composites, JOURNAL OF THERMAL ANALYSIS AND CALORIMETRY, Volume: 127, Issue: 1, Pages: 115-122, ISSN: 1388-6150, eISSN: 1588-2926, 2017;	1.953 / Q2
87.	Niyonzima, S., Ilie, S., Pop, N., Mezei, J.Z., Chakrabarti, K., Morel, V., Peres, B., Little, D.A., Hassouni, K., Larson, A., Orel, A.E., Benredjem, D., Bultel, A., Tennyson, J., Reiter, D., Schneider, I.F. Low-energy collisions between electrons and BeH <sup>+</sup> : Cross sections and rate coefficients for all the vibrational states of the ion, ATOMIC DATA AND NUCLEAR DATA TABLES, Volume: 115, Pages: 287-308, ISSN: 0092-640X, eISSN: 1090-2090, 2017;	1.689 / Q2
88.	Oncioiu, I., Petrescu, A.G., Grecu, E., Petrescu, M. Optimizing the Renewable Energy Potential: Myth or Future Trend in Romania, ENERGIES, Volume: 10, Issue: 6, ISSN: 1996-1073, 2017;	2.262 / Q2
89.	Orha, C., Pode, R., Manea, F., Lazau, C., Bandas, C. Titanium dioxide-modified activated carbon for advanced drinking water treatment, PROCESS SAFETY AND ENVIRONMENTAL PROTECTION, Volume: 108, Special Issue: SI, Pages: 26-33, ISSN: 0957-5820, eISSN: 1744-3598, 2017;	2.905 / Q1
90.	Osaci, M., Cacciola, M. Study about the nanoparticle agglomeration in a magnetic nanofluid by the Langevin dynamics simulation model using an effective Verlet-type algorithm, MICROFLUIDICS AND NANOFUIDICS, Volume: 21, Issue: 2, Article Number: 19, ISSN: 1613-4982, eISSN: 1613-4990, 2017;	2.344 / Q2
91.	Pacurariu, C., Lazau, I., Lazau, R. Kinetic studies of the dehydroxylation and crystallization of raw kaolinite and fluorides-modified kaolinite, JOURNAL OF THERMAL ANALYSIS AND CALORIMETRY, Volume: 127, Issue: 1, Pages: 239-246, ISSN: 1388-6150, eISSN: 1588-2926, 2017;	1.953 / Q2



No.	Article	2016 Impact Factor / Quartile in Category
92.	Pater, F. SOME INEQUALITIES ON POWER BOUNDED OPERATORS ACTING ON LOCALLY CONVEX SPACES, JOURNAL OF MATHEMATICAL INEQUALITIES, Volume: 11, Issue: 2, Pages: 485-494, ISSN: 1846-579X, 2017;	0.777 / Q2
93.	Paulescu, M., Pop, N., Stefu, N., Paulescu, E., Boata, R., Calinoiu, D. SEASONAL MODELING OF HOURLY SOLAR IR-RADIATION SERIES, ROMANIAN JOURNAL OF PHYSICS, Volume: 62, Issue: 7-8, Article Number: 813, ISSN: 1221-146X, 2017;	1.758 / Q2
94.	Pop, A., Manea, F., Flueras, A., Schoonman, J. Simultaneous Voltammetric Detection of Carbaryl and Paraquat Pesticides on Graphene-Modified Boron-Doped Diamond Electrode, SENSORS, Volume: 17, Issue: 9, Article Number: 2033, ISSN: 1424-8220, 2017;	2.677 / Q1
95.	Popa, S., Iliescu, S., Iliu, G., Plesu, N., Popa, A., Visa, A., Macarie, L. Solid polymer electrolytes based on phosphorus containing polymers for lithium polymer batteries, EUROPEAN POLYMER JOURNAL, Volume: 94, Pages: 286-298, ISSN: 0014-3057, eISSN: 1873-1945, 2017;	3.531 / Q1
96.	Popov, D. ON SOME PROPERTIES OF THE K-COHERENT STATES, PROCEEDINGS OF THE ROMANIAN ACADEMY SERIES A-MATHEMATICS PHYSICS TECHNICAL SCIENCES INFORMATION SCIENCE, Volume: 18, Issue: 4, Pages: 323-330, ISSN: 1454-9069, 2017;	1.623 / Q2
97.	Pozna, C., Precup, R.E. On a translated frame-based approach to geometric modeling of robots, ROBOTICS AND AUTONOMOUS SYSTEMS, Volume: 91, Pages: 49-58, ISSN: 0921-8890, eISSN: 1872-793X, 2017;	1.95 / Q2
98.	Precup, R.E., Radac, M.B., Roman, R.C., Petriu, E.M. Model-free sliding mode control of nonlinear systems: Algorithms and experiments, INFORMATION SCIENCES, Volume: 381, Pages: 176-192, ISSN: 0020-0255, eISSN: 1872-6291, 2017;	4.832 / Q1
99.	Precup, R.E., David, R.C., Petriu, E.M. Grey Wolf Optimizer Algorithm-Based Tuning of Fuzzy Control Systems With Reduced Parametric Sensitivity, IEEE TRANSACTIONS ON INDUSTRIAL ELECTRONICS, Volume: 64, Issue: 1, Pages: 527-534, ISSN: 0278-0046, eISSN: 1557-9948, 2017;	7.168 / Q1
100.	Racuciu, M., Iftode, C., Miclaus, S. ULTRAHIGH FREQUENCY-LOW POWER ELECTROMAGNETIC FIELD IMPACT ON PHYSIOLOGICAL PARAMETERS OF TWO TYPES OF CEREALS, ROMANIAN REPORTS IN PHYSICS, Volume: 69, Issue: 4, Article Number: 712, ISSN: 1221-1451, eISSN: 1841-8759, 2017;	1.467 / Q2
101.	Radac, M.B., Precup, R.E., Roman, R.C. Model-Free control performance improvement using virtual reference feedback tuning and reinforcement Q-learning, INTERNATIONAL JOURNAL OF SYSTEMS SCIENCE, Volume: 48, Issue: 5, Pages: 1071-1083, ISSN: 0020-7721, eISSN: 1464-5319, 2017;	2.285 / Q1
102.	Ramasamy, P., Stoica, M., Bera, S., Calin, M., Eckert, J. Effect of replacing Nb with (Mo and Zr) on glass forming ability, magnetic and mechanical properties of FeCoBSiNb bulk metallic glass, JOURNAL OF ALLOYS AND COMPOUNDS, Volume: 707, Pages: 78-81, ISSN: 0925-8388, eISSN: 1873-4669, 2017;	3.133 / Q1
103.	Sarac, B., Bernasconi, A., Wright, J., Stoica, M., Spieckermann, F., Muhlbacher, M., Keckes, J., Bian, X., Wang, G., Eckert, J. Structural modifications in sub-T-g annealed CuZr-based metallic glass, MATERIALS SCIENCE AND ENGINEERING A-STRUCTURAL MATERIALS PROPERTIES MICROSTRUCTURE AND PROCESSING, Volume: 707, Pages: 245-252, ISSN: 0921-5093, eISSN: 1873-4936, 2017;	3.094 / Q1
104.	Sarac, B., Bera, S., Spieckermann, F., Balakin, S., Stoica, M., Calin, M., Eckert, J. Micropatterning kinetics of different glass-forming systems investigated by thermoplastic net-shaping, SCRIPTA MATERIALIA, Volume: 137, Pages: 127-131, ISSN: 1359-6462, 2017;	3.747 / Q1

No.	Article	2016 Impact Factor / Quartile in Category
105.	Sarac, B., Bera, S., Balakin, S., Stoica, M., Calin, M., Eckert, J. Hierarchical surface patterning of Ni- and Be-free Ti- and Zr-based bulk metallic glasses by thermoplastic net-shaping, MATERIALS SCIENCE & ENGINEERING C-MATERIALS FOR BIOLOGICAL APPLICATIONS, Volume: 73, Pages: 398-405, PubMed ID: 28183624, ISSN: 0928-4931, eISSN: 1873-0191, 2017;	4.164 / Q2
106.	Stefan, D., Rudolf, P., Muntean, S., Susan-Resiga, R. Proper Orthogonal Decomposition of Self-Induced Instabilities in Decelerated Swirling Flows and Their Mitigation Through Axial Water Injection, JOURNAL OF FLUIDS ENGINEERING-TRANSACTIONS OF THE ASME, Volume: 139, Issue: 8, Article Number: 081101, ISSN: 0098-2202, eISSN: 1528-901X, 2017;	1.437 / Q2
107.	Stoia, M., Muntean, E., Pacurariu, C., Mihali, C. Thermal behavior of MnFe <sub>2</sub> O <sub>4</sub> and MnFe <sub>2</sub> O <sub>4</sub> /C nanocomposite synthesized by a solvothermal method, THERMOCHIMICA ACTA, Volume: 652, Pages: 1-8, ISSN: 0040-6031, eISSN: 1872-762X, 2017;	2.236 / Q2
108.	Stoia, M., Muntean, C., Militaru, B. MnFe <sub>2</sub> O <sub>4</sub> nanoparticles as new catalyst for oxidative degradation of phenol by peroxydisulfate, JOURNAL OF ENVIRONMENTAL SCIENCES, Volume: 53, Pages: 269-277, PubMed ID: 28372751, ISSN: 1001-0742, eISSN: 1878-7320, 2017;	2.865 / Q2
109.	Stoia, M., Barvinschi, P., Barbu-Tudoran, L., Bunoiu, M. Influence of polyols on the formation of nanocrystalline nickel ferrite inside silica matrices, JOURNAL OF CRYSTAL GROWTH, Volume: 457, Special Issue: SI, Pages: 294-301, ISSN: 0022-0248, eISSN: 1873-5002, 2017;	1.751 / Q2
110.	Stoia, M., Pacurariu, C., Muntean, E.C., Thermal stability of the solvothermal-synthesized MnFe <sub>2</sub> O <sub>4</sub> nanopowder, JOURNAL OF THERMAL ANALYSIS AND CALORIMETRY, Volume: 127, Issue: 1, Pages: 155-162, ISSN: 1388-6150, eISSN: 1588-2926, 2017;	1.953 / Q2
111.	Susan-Resiga, D., Vekas, L. Ferrofluid based composite fluids: Magnetorheological properties correlated by Mason and Casson numbers, JOURNAL OF RHEOLOGY, Volume: 61, Issue: 3, Pages: 401-408, ISSN: 0148-6055, 2017;	3.136 / Q1
112.	Tigan, G., Llibre, J., Ciurdariu, L. Degenerate Fold-Hopf Bifurcations in a Rossler-Type System, INTERNATIONAL JOURNAL OF BIFURCATION AND CHAOS, Volume: 27, Issue: 5, Article Number: 1750068, ISSN: 0218-1274, eISSN: 1793-6551, 2017;	1.329 / Q2
113.	Tigan, G. DEGENERATE WITH RESPECT TO PARAMETERS FOLD-HOPF BIFURCATIONS, DISCRETE AND CONTINUOUS DYNAMICAL SYSTEMS, Volume: 37, Issue: 4, Pages: 2115-2140, ISSN: 1078-0947, eISSN: 1553-5231, 2017;	1.099 / Q1
114.	Tigan, G. Using Melnikov functions of any order for studying limit cycles, JOURNAL OF MATHEMATICAL ANALYSIS AND APPLICATIONS, Volume: 448, Issue: 1, Pages: 409-420, ISSN: 0022-247X, eISSN: 1096-0813, 2017;	1.064 / Q1
115.	Tiwari, A.K., Albulescu, C.T., Yoon, S.M. A multifractal detrended fluctuation analysis of financial market efficiency: Comparison using Dow Jones sector ETF indices, PHYSICA A-STATISTICAL MECHANICS AND ITS APPLICATIONS, Volume: 483, Pages: 182-192, ISSN: 0378-4371, eISSN: 1873-2119, 2017;	2.243 / Q1
116.	Topirceanu, A. Breaking up friendships in exams: A case study for minimizing student cheating in higher education using social network analysis, COMPUTERS & EDUCATION, Volume: 115, Pages: 171-187, ISSN: 0360-1315, eISSN: 1873-782X, 2017;	3.819 / Q1
117.	Topirceanu, A., Udrescu, M. Statistical fidelity: a tool to quantify the similarity between multi-variable entities with application in complex networks, INTERNATIONAL JOURNAL OF COMPUTER MATHEMATICS, Volume: 94, Issue: 9, Pages: 1787-1805, ISSN: 0020-7160, eISSN: 1029-0265, 2017;	0.971 / Q2

No.	Article	2016 Impact Factor / Quartile in Category
118.	Totorean, A.F., Hudrea, C.I., Bosioc, A.I., Bernad, S.I. FLOW FIELD EVOLUTION IN STENTED VERSUS STENOSED CORONARY ARTERY, PROCEEDINGS OF THE ROMANIAN ACADEMY SERIES A-MATHEMATICS PHYSICS TECHNICAL SCIENCES INFORMATION SCIENCE, Volume: 18, Issue: 3, Pages: 248-255, ISSN: 1454-9069, 2017;	1.623 / Q2
119.	Tudoran, R.M., Girban, A. Bifurcations of limit cycles of perturbed completely integrable systems, NONLINEARITY, Volume: 30, Issue: 3, Pages: 1058-1088, ISSN: 0951-7715, eISSN: 1361-6544, 2017;	1.767 / Q1
120.	Ungurean, L., Carstoiu, G., Micea, M.V., Groza, V. Battery state of health estimation: a structured review of models, methods and commercial devices, INTERNATIONAL JOURNAL OF ENERGY RESEARCH, Volume: 41, Issue: 2, Pages: 151-181, ISSN: 0363-907X, eISSN: 1099-114X, 2017;	2.598 / Q1
121.	Utu, I.D., Marginean, G. Effect of electron beam remelting on the characteristics of HVOF sprayed Al <sub>2</sub> O <sub>3</sub> -TiO <sub>2</sub> coatings deposited on titanium substrate, COLLOIDS AND SURFACES A-PHYSICOCHEMICAL AND ENGINEERING ASPECTS, Volume: 526, Special Issue: SI, Pages: 70-75, ISSN: 0927-7757, eISSN: 1873-4359, 2017;	2.714 / Q2
122.	Vlazan, P., Stoia, M., Poienar, M., Sfirloaga, P. Phase transition behaviour and physicochemical properties of KNbO <sub>3</sub> ceramics, CERAMICS INTERNATIONAL, Volume: 43, Issue: 8, Pages: 5963-5967, ISSN: 0272-8842, eISSN: 1873-3956, 2017;	2.986 / Q1
123.	Vulcu, C., Stratan, A., Ciutina, A., Dubina, D. Beam-to-CFT High-Strength Joints with External Diaphragm. II: Numerical Simulation of Joint Behavior, JOURNAL OF STRUCTURAL ENGINEERING, Volume: 143, Issue: 5, Article Number: 04017002, ISSN: 0733-9445, eISSN: 1943-541X, 2017;	2.021 / Q2
124.	Vulcu, C., Stratan, A., Ciutina, A., Dubina, D. Beam-to-CFT High-Strength Joints with External Diaphragm. I: Design and Experimental Validation, JOURNAL OF STRUCTURAL ENGINEERING, Volume: 143, Issue: 5, Article Number: 04017001, ISSN: 0733-9445, eISSN: 1943-541X, 2017;	2.021 / Q2
125.	Zhang, L., He, Z.Y., Tan, J., Zhang, Y.Q., Stoica, M., Calin, M., Prashanth, K.G., Cordill, M.J., Jiang, Y.H., Zhou, R., Eckert, J. Designing a novel functional-structural NiTi/hydroxyapatite composite with enhanced mechanical properties and high bioactivity, INTERMETALLICS, Volume: 84, Pages: 35-41, ISSN: 0966-9795, eISSN: 1879-0216, 2017;	3.14 / Q1
126.	Zhang, L., He, Z.Y., Tan, J., Zhang, Y.Q., Stoica, M., Prashanth, K.G., Cordill, M.J., Jiang, Y.H., Zhou, R., Eckert, J. Rapid fabrication of function-structure-integrated NiTi alloys: Towards a combination of excellent superelasticity and favorable bioactivity, INTERMETALLICS, Volume: 82, Pages: 1-13, ISSN: 0966-9795, eISSN: 1879-0216, 2017;	3.14 / Q1

# Papers in ISI Journals



1. Abdullah, A.D., Popescu, I., Dastgheib, A., van der Zaag, P., Masih, I., Karim, U.F.A. Analysis of Possible Actions to Manage the Longitudinal Changes of Water Salinity in a Tidal River, *WATER RESOURCES MANAGEMENT*, Volume: 31, Issue: 7, Pages: 2157-2171, ISSN: 0920-4741, eISSN: 1573-1650, 2017;
2. Albulescu, C.T., Oros, C., Tiwari, A.K. Is there any convergence in health expenditures across EU countries?, *ECONOMICS BULLETIN*, Volume: 37, Issue: 3, Pages: 2095-2101, ISSN: 1545-2921, 2017;
3. Albulescu, C.T., Goyeau, D., Tiwari, A.K. Co-movements and contagion between international stock index futures markets, *EMPIRICAL ECONOMICS*, Volume: 52, Issue: 4, Pages: 1529-1568, ISSN: 0377-7332, eISSN: 1435-8921, 2017;
4. Albulescu, C.T., Oros, C., Tiwari, A.K. Oil price-inflation pass-through in Romania during the inflation targeting regime, *APPLIED ECONOMICS*, Volume: 49, Issue: 15, Pages: 1527-1542, ISSN: 0003-6846, eISSN: 1466-4283, 2017;
5. Albulescu, C.T., Aubin, C., Goyeau, D. Stock prices, inflation and inflation uncertainty in the US: testing the long-run relationship considering Dow Jones sector indexes, *APPLIED ECONOMICS*, Volume: 49, Issue: 18, Pages: 1794-1807, ISSN: 0003-6846, eISSN: 1466-4283, 2017;
6. Albulescu, C.T. UK business cycle synchronization with Germany and the US: New evidence from time-frequency domain and structure of economic growth, *APPLIED ECONOMICS LETTERS*, Volume: 24, Issue: 1, Pages: 67-71, ISSN: 1350-4851, eISSN: 1466-4291, 2017;
7. Amaricai, A., Sicoe, O., Boncalo, O. On the Redundant Representation of Partial Remainders in Radix-4 SRT Dividers, *JOURNAL OF CIRCUITS SYSTEMS AND COMPUTERS*, Volume: 26, Issue: 6, Article Number: 1750097, ISSN: 0218-1266, eISSN: 1793-6454, 2017;
8. Amaricai, A. Design Trade-offs in Configurable FPGA Architectures for K-Means Clustering, *STUDIES IN INFORMATICS AND CONTROL*, Volume: 26, Issue: 1, Pages: 43-48, ISSN: 1220-1766, 2017;
9. Ancusa, V.M., Ban, O., Cornea, M. An Intelligent Method to Process Romanian Language Internet Reviews, *BRAIN-BROAD RESEARCH IN ARTIFICIAL INTELLIGENCE AND NEUROSCIENCE*, Volume: 8, Issue: 3, Pages: 77-84, ISSN: 2067-3957, 2017;
10. Ancusa, V.M., Dragoie, C.M. Cursor Movement - a Valuable Indicator in Intelligent System Design, *BRAIN-BROAD RESEARCH IN ARTIFICIAL INTELLIGENCE AND NEUROSCIENCE*, Volume: 8, Issue: 2, Pages: 45-55, ISSN: 2067-3957, 2017;
11. Ancuti, C.O., Ancuti, C., De Vleeschouwer, C., Bovik, A.C. Single-Scale Fusion: An Effective Approach to Merging Images, *IEEE TRANSACTIONS ON IMAGE PROCESSING*, Volume: 26, Issue: 1, Pages: 65-78, PubMed ID: 27810821, ISSN: 1057-7149, eISSN: 1941-0042, 2017;
12. Anghel, I., Lalu, O., Codescu, S., Pescic, D.J., Branisteanu, B., Popa, C. EXPERIMENTAL INVESTIGATION ON THE CHARACTERISTICS OF FIRES IN A REDUCED 1/10 SCALE ROAD TUNNEL USING DIFFERENT COMBUSTIBLE LIQUID POOLS, *ACTA TECHNICA NAPOCENSIS SERIES-APPLIED MATHEMATICS MECHANICS AND ENGINEERING*, Volume: 60, Issue: 2, Pages: 217-226, ISSN: 1221-5872, 2017;
13. Ardelean, E., Socalici, A., Pascu, L., Putan, V., Heput, T. Laboratory Researches Regarding Wear of the Composite Materials for Making Brake Shoes, *MATERIALE PLASTICE*, Volume: 54, Issue: 2, Pages: 203-206, ISSN: 0025-5289, 2017;
14. Ardelean, M., Manea, F., Pop, A., Pode, R., Schoonman, J. ELECTROCHEMICAL DETECTION OF FLUOXETINE IN WATER USING A SILVER MODIFIED ZEOLITE-CARBON NANOFIBER ELECTRODE, *ENVIRONMENTAL ENGINEERING AND MANAGEMENT JOURNAL*, Volume: 16, Issue: 4, Pages: 829-836, ISSN: 1582-9596, eISSN: 1843-3707, 2017;
15. Babau, C., Marcu, M., Tihu, M., Telbis, D., Cretu, V. A Personalized Multi-Path and Multi-User Traffic Analysis and Visualization Tool, *ACTA CYBERNETICA*, Volume: 23, Issue: 2, Pages: 441-470, ISSN: 0324-721X, 2017;
16. Baci, A., Manea, F., Pop, A., Pode, R., Schoonman, L. Simultaneous voltammetric detection of ammonium and nitrite from groundwater at silver-electrodecorated carbon nanotube electrode, *PROCESS SAFETY AND ENVIRONMENTAL PROTECTION*, Volume: 108, Special Issue: SI, Pages: 18-25, ISSN: 0957-5820, eISSN: 1744-3598, 2017;
17. Baloi, M.A., Crucean, C. Fermion production by a dependent of time electric field in de Sitter universe, *INTERNATIONAL JOURNAL OF MODERN PHYSICS A*, Volume: 32, Issue: 36, Special Issue: SI, Article Number: 1750208, ISSN: 0217-751X, eISSN: 1793-656X, 2017;
18. Banica, R., Ursu, D., Nyari, T., Kellenberger, A. Polyol synthesis of silver nanowires in the presence of silver chloride, *JOURNAL OF OPTOELECTRONICS AND ADVANCED MATERIALS*, Volume: 19, Issue: 3-4, Pages: 266-271, ISSN: 1454-4164, eISSN: 1841-7132, 2017;
19. Banica, R., Ursu, D., Nyari, T., Kellenberger, A. Two step polyol-solvothermal growth of thick silver nanowires, *MATERIALS LETTERS*, Volume: 194, Pages: 181-184, ISSN: 0167-577X, eISSN: 1873-4979, 2017;

20. Barna, L., Lelea, D. LOW PRESSURE INJECTION OF OXYHYDROGEN IN TURBOCHARGED COMPRESSION IGNITION ENGINES, *TEHNICKI VJESNIK-TECHNICAL GAZETTE*, Volume: 24, Pages: 287-294, Supplement: 2, ISSN: 1330-3651, eISSN: 1848-6339, 2017;
21. Beilicci, E., David, I., Beilicci, R., Visescu, M. MATHEMATICAL MODEL FOR CALCULATION OF SOIL LOSS ON WATERSHED SLOPES, *ENVIRONMENTAL ENGINEERING AND MANAGEMENT JOURNAL*, Volume: 16, Issue: 10, Pages: 2211-2218, ISSN: 1582-9596, eISSN: 1843-3707, 2017;
22. Beiu, R.M., Beiu, V., Duma, V.F. Fiber optic mechanical deformation sensors employing perpendicular photonic crystals, *OPTICS EXPRESS*, Volume: 25, Issue: 19, Pages: 23388-23398, PubMed ID: 29041640, ISSN: 1094-4087, 2017;
23. Belega, D., Petri, D. Effect of noise and harmonics on sine-wave frequency estimation by interpolated DFT algorithms based on few observed cycles, *SIGNAL PROCESSING*, Volume: 140, Pages: 207-218, ISSN: 0165-1684, eISSN: 1879-2677, 2017;
24. Bento, A.J.G., Lupa, N., Megan, M., Silva, C.M. INTEGRAL CONDITIONS FOR NONUNIFORM  $\mu$ -DICHOTOMY ON THE HALF-LINE, DISCRETE AND CONTINUOUS DYNAMICAL SYSTEMS-SERIES B, Volume: 22, Issue: 8, Special Issue: SI, Pages: 3063-3077, ISSN: 1531-3492, eISSN: 1553-524X, 2017;
25. Bera, S., Sarac, B., Balakin, S., Ramasamy, P., Stoica, M., Calin, M., Eckert, J. Micro-patterning by thermoplastic forming of Ni-free Ti-based bulk metallic glasses, *MATERIALS & DESIGN*, Volume: 120, Pages: 204-211, ISSN: 0264-1275, eISSN: 1873-4197, 2017;
26. Biliuta, G., Sacarescu, L., Socoliuc, V., Iacob, M., Gheorghe, L., Negru, D., Coseri, S. Carboxylated Polysaccharides Decorated with Ultrasmall Magnetic Nanoparticles with Antibacterial and MRI Properties, *MACROMOLECULAR CHEMISTRY AND PHYSICS*, Volume: 218, Issue: 10, Article Number: 1700062, ISSN: 1022-1352, eISSN: 1521-3935, 2017;
27. Binzar, T., Lazureanu, C. On the Wold-Type Decompositions for n-Tuples of Commuting Isometric Semigroups, *FILOMAT*, Volume: 31, Issue: 5, Pages: 1251-1264, ISSN: 0354-5180, 2017;
28. Bistran, D.A., Navon, I.M. The method of dynamic mode decomposition in shallow water and a swirling flow problem, *INTERNATIONAL JOURNAL FOR NUMERICAL METHODS IN FLUIDS*, Volume: 83, Issue: 1, Pages: 73-89, ISSN: 0271-2091, eISSN: 1097-0363, 2017;
29. Bistran, D.A., Navon, I.M. Randomized dynamic mode decomposition for nonintrusive reduced order modelling, *INTERNATIONAL JOURNAL FOR NUMERICAL METHODS IN ENGINEERING*, Volume: 112, Issue: 1, Pages: 3-25, ISSN: 0029-5981, eISSN: 1097-0207, 2017;
30. Bizerea-Spiridon, O., Nartita, R., Rogobete, A.F., Negrea, A., Stroescu, R., Bizerea, T.O., Ilie, C., Marginean, O. Spectrophotometric Determination of Selenium Through Triiodide Anion, *CLINICAL LABORATORY*, Volume: 63, Issue: 5-6, Pages: 887-899, PubMed ID: 28627816, ISSN: 1433-6510, 2017;
31. Bogdan, R. Integrating MOOCs in Embedded Systems Blended Courses, *BRAIN-BROAD RESEARCH IN ARTIFICIAL INTELLIGENCE AND NEUROSCIENCE*, Volume: 8, Issue: 3, Pages: 101-107, ISSN: 2067-3957, 2017;
32. Bogdan, R. Sentiment Analysis on Embedded Systems Blended Courses, *BRAIN-BROAD RESEARCH IN ARTIFICIAL INTELLIGENCE AND NEUROSCIENCE*, Volume: 8, Issue: 1, Pages: 17-23, ISSN: 2067-3957, 2017;
33. Bojan-Dragos, C.A., Precup, R.E., Tomescu, M.L., Preitl, S., Tanasoiu, O.M., Hergane, S. Proportional-Integral-Derivative Gain-Scheduling Control of a Magnetic Levitation System, *INTERNATIONAL JOURNAL OF COMPUTERS COMMUNICATIONS & CONTROL*, Volume: 12, Issue: 5, Pages: 599-611, ISSN: 1841-9836, eISSN: 1841-9844, 2017;
34. Boran, S., Nitu, S. Synthesis and Characterization of Some Ester-type Biolubricants of Soiabean Fatty Acids, *MATERIALE PLASTICE*, Volume: 54, Issue: 2, Pages: 386-389, ISSN: 0025-5289, 2017;
35. Bordeasu, I., Mitelea, I., Lazar, I., Micu, L.M., Karancsi, O. Cavitation Erosion Behaviour of Cooper Base Layers Deposited by HVOF Thermal Spraying, *REVISTA DE CHIMIE*, Volume: 68, Issue: 12, Pages: 2914-2917, ISSN: 0034-7752, 2017;
36. Borlea, I.D., Precup, R.E., Dragan, F., Borlea, A.B. Centroid Update Approach to K-Means Clustering, *ADVANCES IN ELECTRICAL AND COMPUTER ENGINEERING*, Volume: 17, Issue: 4, Pages: 3-10, ISSN: 1582-7445, eISSN: 1844-7600, 2017;
37. Boros, I., Tanasa, C., Stoian, V., Dan, D. LIFE CYCLE ASSESSMENT AND LIFE CYCLE COST ANALYSIS OF A NEARLY ZERO ENERGY RESIDENTIAL BUILDING - A CASE STUDY, *ENVIRONMENTAL ENGINEERING AND MANAGEMENT JOURNAL*, Volume: 16, Issue: 3, Pages: 695-704, ISSN: 1582-9596, eISSN: 1843-3707, 2017;
38. Bota, C., Caruntu, B., Lazureanu, C. THE LEAST SQUARE HOMOTOPY PERTURBATION METHOD FOR BOUNDARY VALUE PROBLEMS, *APPLIED AND COMPUTATIONAL MATHEMATICS*, Volume: 16, Issue: 1, Pages: 39-47, ISSN: 1683-3511, eISSN: 1683-6154, 2017;

39. Bota, C., Caruntu, B. Analytical approximate solutions for quadratic Riccati differential equation of fractional order using the Polynomial Least Squares Method, *CHAOS SOLITONS & FRACTALS*, Volume: 102, Pages: 339-345, ISSN: 0960-0779, eISSN: 1873-2887, 2017;
40. Bota, C., Caruntu, B. ANALYTIC APPROXIMATE SOLUTIONS FOR A CLASS OF VARIABLE ORDER FRACTIONAL DIFFERENTIAL EQUATIONS USING THE POLYNOMIAL LEAST SQUARES METHOD, *FRACTIONAL CALCULUS AND APPLIED ANALYSIS*, Volume: 20, Issue: 4, Pages: 1043-1050, ISSN: 1311-0454, eISSN: 1314-2224, 2017;
41. Bota, C., Caruntu, B. Approximate analytical solutions of nonlinear differential equations using the Least Squares Homotopy Perturbation Method, *JOURNAL OF MATHEMATICAL ANALYSIS AND APPLICATIONS*, Volume: 448, Issue: 1, Pages: 401-408, ISSN: 0022-247X, eISSN: 1096-0813, 2017;
42. Bota, C. The approximation of solutions for second order nonlinear oscillators using the polynomial least square method, *JOURNAL OF NON-LINEAR SCIENCES AND APPLICATIONS*, Volume: 10, Issue: 1, Pages: 234-242, ISSN: 2008-1898, eISSN: 2008-1901, 2017;
43. Broasca, L., Ancusa, V.M., Ciocarlie, H. Social Media as Medical Validator, *BRAIN-BROAD RESEARCH IN ARTIFICIAL INTELLIGENCE AND NEUROSCIENCE*, Volume: 8, Issue: 3, Pages: 47-56, ISSN: 2067-3957, 2017;
44. Buncianu, D., Tessier-Doyen, N., Courreges, F., Absi, J. Effect of thermal treatment of a clay-based raw material on porosity and thermal conductivity: experimental approach, image processing and numerical simulation, *EUROPEAN JOURNAL OF ENVIRONMENTAL AND CIVIL ENGINEERING*, Volume: 21, Issue: 10, Pages: 1270-1284, ISSN: 1964-8189, eISSN: 2116-7214, 2017;
45. Buse, C., O'Regan, D., Saierli, O. An inequality concerning the growth bound of an evolution family and the norm of a convolution operator, *SEMIGROUP FORUM*, Volume: 94, Issue: 3, Pages: 618-631, ISSN: 0037-1912, eISSN: 1432-2137, 2017;
46. Butnar, L.A., Basarman, A.P., Tranisan, D.I., Groza, I. FEA Deformations Analysing of the Polyurethane Armchair Seat, *MATERIALE PLASTICE*, Volume: 54, Issue: 3, Pages: 593-595, ISSN: 0025-5289, 2017;
47. Calinoiu, D.G., Trif-Tordai, G., Ionel, I. REVIEW OF SOLAR IRRADIANCE MODEL UNDER CLEAR SKY CONDITION, *JOURNAL OF ENVIRONMENTAL PROTECTION AND ECOLOGY*, Volume: 18, Issue: 1, Pages: 158-167, ISSN: 1311-5065, 2017;
48. Casu, I., Lazureanu, C. Stability and Integrability Aspects for the Maxwell - Bloch Equations with the Rotating Wave Approximation, *REGULAR & CHAOTIC DYNAMICS*, Volume: 22, Issue: 2, Pages: 109-121, ISSN: 1560-3547, eISSN: 1468-4845, 2017;
49. Cebrucean, D., Cebrucean, V., Ionel, I., Spliethoff, H. Performance of two iron-based syngas-fueled chemical looping systems for hydrogen and/or electricity generation combined with carbon capture, *CLEAN TECHNOLOGIES AND ENVIRONMENTAL POLICY*, Volume: 19, Issue: 2, Pages: 451-470, ISSN: 1618-954X, eISSN: 1618-9558, 2017;
50. Cernescu, A. The influence of crack tip shielding on fatigue crack propagation, *FRATTURA ED INTEGRITA STRUTTURALE*, Issue: 41, Pages: 307-313, ISSN: 1971-8993, 2017;
51. Chirila, C.B. Auto-generative Learning Objects in Online Assessment of Data Structures Disciplines, *BRAIN-BROAD RESEARCH IN ARTIFICIAL INTELLIGENCE AND NEUROSCIENCE*, Volume: 8, Issue: 1, Pages: 24-34, ISSN: 2067-3957, 2017;
52. Cioabla, A.E., Djuric, A., Dumitrel, G.A., Chirila, D., Pode, V. BIOGAS PRODUCTION USING WASTE WATERS - INFLUENCE OF PROCESS PARAMETERS FOR TEST RIG AT LABORATORY SCALE, *STUDIA UNIVERSITATIS BABES-BOLYAI CHEMIA*, Volume: 62, Issue: 1, Pages: 51-60, ISSN: 1224-7154, 2017;
53. Cioabla, A.E., Dumitrel, G.A., Ionel, I. Evaluation by Kinetic Models of Anaerobe Digestion Performances for Various Substrates and Co-substrates, *REVISTA DE CHIMIE*, Volume: 68, Issue: 11, Pages: 2614-2617, ISSN: 0034-7752, 2017;
54. Cioabla, A.E., Pop, N., Trif-Tordai, G., Calinoiu, D.G. Comparative analysis of agricultural materials influenced by anaerobic fermentation for biogas production in terms of ash melting behavior, *JOURNAL OF THERMAL ANALYSIS AND CALORIMETRY*, Volume: 127, Issue: 1, Pages: 515-523, ISSN: 1388-6150, eISSN: 1588-2926, 2017;
55. Ciobanu, M., Naaji, A., Dascal, I., Virag, I. Pseudo-holographic Displays as Teaching Tools in Mathematics, *BRAIN-BROAD RESEARCH IN ARTIFICIAL INTELLIGENCE AND NEUROSCIENCE*, Volume: 8, Issue: 3, Pages: 108-118, ISSN: 2067-3957, 2017;
56. Cioca, L.I., Ivascu, L. Risk Indicators and Road Accident Analysis for the Period 2012-2016, *SUSTAINABILITY*, Volume: 9, Issue: 9, Article Number: 1530, ISSN: 2071-1050, 2017;



57. Cioca, M., Ivascu, L., Cioca, L.I. SAFETY PERFORMANCE INDICATORS IN THE METALLURGICAL INDUSTRY USING WEB PROGRAMMING, METAL-URGIJA, Volume: 56, Issue: 1-2, Pages: 272-274, ISSN: 0543-5846, eISSN: 1334-2576, 2017;
58. Ciurdariu, L. SOME APPLICATIONS OF YOUNG-TYPE INEQUALITIES FOR OPERATORS AND MATRICES, JOURNAL OF SCIENCE AND ARTS, Issue: 4, Pages: 631-640, ISSN: 1844-9581, 2017;
59. Corici, L.N., Shova, S., Badea, V., Aparaschivei, D., Costisor, O., Cseh, L. Investigations on the photochromic properties of 2,6-bis(5-bromo-2-hydroxybenzylidene)cyclohexanone, PHOTOCHEMICAL & PHOTOBIOLOGICAL SCIENCES, Volume: 16, Issue: 6, Pages: 946-953, PubMed ID: 28443924, ISSN: 1474-905X, eISSN: 1474-9092, 2017;
60. Coricovac, D.E., Moaca, E.A., Pinzaru, I., Citu, C., Soica, C., Mihali, C.V., Pacurariu, C., Tutelyan, V.A., Tsatsakis, A., Dehelean, C.A. Biocompatible Colloidal Suspensions Based on Magnetic Iron Oxide Nanoparticles: Synthesis, Characterization and Toxicological Profile, FRONTIERS IN PHARMACOLOGY Volume: 8 Article Number: UNSP 154, PubMed ID: 28400730, ISSN: 1663-9812, 2017;
61. Cornea, O., Andreescu, G.D., Muntean, N., Hulea, D. Bidirectional Power Flow Control in a DC Microgrid Through a Switched-Capacitor Cell Hybrid DC-DC Converter, IEEE TRANSACTIONS ON INDUSTRIAL ELECTRONICS, Volume: 64, Issue: 4, Pages: 3012-3022, ISSN: 0278-0046, eISSN: 1557-9948, 2017;
62. Craciunescu, I., Petran, A., Liebscher, J., Vekas, L., Turcu, R. Synthesis and characterization of size-controlled magnetic clusters functionalized with polymer layer for wastewater depollution, MATERIALS CHEMISTRY AND PHYSICS, Volume: 185, Pages: 91-97, ISSN: 0254-0584, eISSN: 1879-3312, 2017;
63. Davidescu, C.M., Gabor, A., Negrea, A., Ciopec, M., Negrea, P., Motoc, M. Novel Adsorbent Used for Cesium Removal from Aqueous Solutions, REVISTA DE CHIMIE, Volume: 68, Issue: 3, Pages: 470-473, ISSN: 0034-7752, 2017;
64. De Sabata, A., Matekovits, L., Lipan, O. Band pattern of commensurate modulated periodic structures, IET MICROWAVES ANTENNAS & PROPAGATION, Volume: 11, Issue: 9, Pages: 1303-1307, ISSN: 1751-8725, eISSN: 1751-8733, 2017;
65. Dinu, F., Marginean, I., Dubina, D. Experimental testing and numerical modelling of steel moment-frame connections under column loss, ENGINEERING STRUCTURES, Volume: 151, Pages: 861-878, ISSN: 0141-0296, eISSN: 1873-7323, 2017;
66. Dogariu, A.I., Dubina, D. STRENGTHENING OF MASONRY SHEAR WALLS BASED ON METAL SOLUTIONS. PART II: FE-MODEL FOR THE PERFORMANCE EVALUATION, PROCEEDINGS OF THE ROMANIAN ACADEMY SERIES A-MATHEMATICS PHYSICS TECHNICAL SCIENCES INFORMATION SCIENCE, Volume: 18, Issue: 2, Pages: 158-165, ISSN: 1454-9069, 2017;
67. Dogariu, A.I., Dubina, D. STRENGTHENING OF MASONRY SHEAR WALLS BASED ON METAL SOLUTIONS. PART I: EXPERIMENTAL INVESTIGATION, PROCEEDINGS OF THE ROMANIAN ACADEMY SERIES A-MATHEMATICS PHYSICS TECHNICAL SCIENCES INFORMATION SCIENCE, Volume: 18, Issue: 1, Pages: 81-88, ISSN: 1454-9069, 2017;
68. Dorin, R., Feier, A., Petzek, E., Bancila, R. Refurbishment of Existing Steel Structures - an Actual Problem, PERIODICA POLYTECHNICA-CIVIL ENGINEERING, Volume: 61, Issue: 3, Pages: 621-631, ISSN: 0553-6626, 2017;
69. Dubar, I.G., Bogdan, R., Popa, M. External Rapid Prototyping Validation System for the Automotive Development Cycle, ACTA POLYTECHNICA HUNGARICA, Volume: 14, Issue: 6, Pages: 41-57, ISSN: 1785-8860, 2017;
70. Duca, D.A., Dan, M.L., Vaszilcsin, N. REUSE OF EXPIRED CEFORT DRUG IN NICKEL ELECTRODEPOSITION FROM WATTS BATH, CHEMISTRY JOURNAL OF MOLDOVA, Volume: 12, Issue: 1, Pages: 87-94, ISSN: 1857-1727, eISSN: 2345-1688, 2017;
71. Duma, V.F. POLYGONAL MIRROR LASER SCANNING HEADS: CHARACTERISTIC FUNCTIONS, PROCEEDINGS OF THE ROMANIAN ACADEMY SERIES A-MATHEMATICS PHYSICS TECHNICAL SCIENCES INFORMATION SCIENCE, Volume: 18, Issue: 1, Pages: 25-33, ISSN: 1454-9069, 2017;
72. Dumitrel, G.A., Glevitzky, M., Popa, M., Chirila, D., Palea, A. MONITORING OF LEAD, COPPER AND CADMIUM CONTAMINATION LEVEL OF SOIL FROM ZLATNA REGION ROMANIA, JOURNAL OF ENVIRONMENTAL PROTECTION AND ECOLOGY, Volume: 18, Issue: 1, Pages: 55-62, ISSN: 1311-5065, 2017;
73. Dumitrel, G.A., Cioabla, A.E., Ionel, I., Varga, L.A. Experimental and Modelling Approach of Biogas Production by Anaerobic Digestion of Agricultural Resources, REVISTA DE CHIMIE, Volume: 68, Issue: 6, Pages: 1294-1297, ISSN: 0034-7752, 2017;

74. Dumitru, R., Manea, F., Lupa, L., Pacurariu, C., Ianculescu, A., Baci, A., Negrea, S. Synthesis, characterization of nanosized CoAl<sub>2</sub>O<sub>4</sub> and its electrocatalytic activity for enhanced sensing application, *JOURNAL OF THERMAL ANALYSIS AND CALORIMETRY*, Volume: 128, Issue: 3, Pages: 1305-1312, ISSN: 1388-6150, eISSN: 1588-2926, 2017;
75. Elfimova, E.A., Ivanov, A.O., Popescu, L.B., Socoliuc, V. Transverse magneto-optical anisotropy in bidisperse ferrofluids with long range particle correlations, *JOURNAL OF MAGNETISM AND MAGNETIC MATERIALS*, Volume: 431, Pages: 54-58, ISSN: 0304-8853, eISSN: 1873-4766, 2017;
76. Enache, A., Dan, M., Kellenberger, A., Vaszilcsin, N. Anodic oxidation of sulphite in alkaline aqueous solution on graphite electrode, *BULGARIAN CHEMICAL COMMUNICATIONS*, Volume: 49, Special Issue: C, Pages: 139-146, ISSN: 0324-1130, 2017;
77. Enache, A.F., Dan, M.L., Vaszilcsin, N. ANODIC OXIDATION OF SULPHITE IN ALKALINE MEDIA ON PLATINUM NANOPARTICLES MODIFIED NICKEL ELECTRODE, *CHEMISTRY JOURNAL OF MOLDOVA*, Volume: 12, Issue: 1, Pages: 102-109, ISSN: 1857-1727, eISSN: 2345-1688, 2017;
78. Ene, R.D., Pop, C. Some new remarks on MHD Jeffery-Hamel fluid flow problem, *OPEN PHYSICS*, Volume: 15, Issue: 1, Pages: 819-826, ISSN: 2391-5471, 2017;
79. Enslin, J.H., Blaabjerg, F., Tan, D. The Future of Electronic Power Processing and Conversion Highlights from FEPPCON IX, *IEEE POWER ELECTRONICS MAGAZINE*, Volume: 4, Issue: 3, Pages: 28-32, ISSN: 2329-9207, eISSN: 2329-9215, 2017;
80. Fagadar-Cosma, E., Badea, V., Fagadar-Cosma, G., Palade, A., Lascu, A., Fringu, I., Birdeanu, M. Trace Oxygen Sensitive Material Based on Two Porphyrin Derivatives in a Heterodimeric Complex, *MOLECULES*, Volume: 22, Issue: 10, Article Number: 1787, ISSN: 1420-3049, 2017;
81. Feier, F., Silea, I., Angelescu, C., Sacala, I.S., Moisescu, M.A. Sound Analysis System of Newborn Cry during Blood Draw with Cerebral Oximetry Monitoring, *CONTROL ENGINEERING AND APPLIED INFORMATICS*, Volume: 19, Issue: 2, Pages: 11-19, ISSN: 1454-8658, 2017;
82. Feniser, C., Burz, G., Mocan, M., Ivascu, L., Gherhes, V., Otel, C.C. The Evaluation and Application of the TRIZ Method for Increasing Eco-Innovative Levels in SMEs, *SUSTAINABILITY*, Volume: 9, Issue: 7, Article Number: 1125, ISSN: 2071-1050, 2017;
83. Filip, I., Szeidert, I. Tuning the control penalty factor of a minimum variance adaptive controller, *EUROPEAN JOURNAL OF CONTROL*, Volume: 37, Pages: 16-26, ISSN: 0947-3580, eISSN: 1435-5671, 2017;
84. Filip-Vacarescu, N., Vulcu, C., Dubina, D. NUMERICAL STUDY OF A HYBRID DAMPING SYSTEM COMPOSED OF A BUCKLING RESTRAINED BRACE WITH A MAGNETO RHEOLOGICAL DAMPER, *PROCEEDINGS OF THE ROMANIAN ACADEMY SERIES A-MATHEMATICS PHYSICS TECHNICAL SCIENCES INFORMATION SCIENCE*, Volume: 18, Issue: 3, Pages: 273-280, ISSN: 1454-9069, 2017;
85. Filipovici, A., Tucu, D., Bialowiec, A., Bukowski, P., Crisan, G.C., Lica, S., Pulka, J., Dyjakon, A., Debowski, M. Effect of Temperature and Heating Rate on the Char Yield in Sorghum and Straw Slow Pyrolysis, *REVISTA DE CHIMIE*, Volume: 68, Issue: 3, Pages: 576-580, ISSN: 0034-7752, 2017;
86. Filippov, S.N., Magadov, K.Y., Jivulescu, M.A. Absolutely separating quantum maps and channels, *NEW JOURNAL OF PHYSICS*, Volume: 19, Article Number: 083010, ISSN: 1367-2630, 2017;
87. Foroughi, A., Ashuri, H., Tavakoli, R., Stoica, M., Soppu, D., Eckert, J. Structural modification through pressurized sub-T-g annealing of metallic glasses, *JOURNAL OF APPLIED PHYSICS*, Volume: 122, Issue: 21, Article Number: 215106, ISSN: 0021-8979, eISSN: 1089-7550, 2017;
88. Frandes, M., Deiac, A.V., Timar, B., Lungeanu, D. Instrument for assessing mobile technology acceptability in diabetes self-management: a validation and reliability study, *PATIENT PREFERENCE AND ADHERENCE*, Volume: 11, Pages: 259-269, PubMed ID: 28243069, ISSN: 1177-889X, 2017;
89. Fuicu, S., Popa, M., Dobrilovic, D., Marcu, M., Bogdam, R. Developing Distance Learning Environments in the Context of Cross-Border Cooperation, *BRAIN-BROAD RESEARCH IN ARTIFICIAL INTELLIGENCE AND NEUROSCIENCE*, Volume: 8, Issue: 1, Pages: 52-58, ISSN: 2067-3957, 2017;
90. Gabor, A., Davidescu, C.M., Negrea, A., Ciopec, M., Grozav, I., Negrea, P., Duteanu, N. Optimizing the lanthanum adsorption process onto chemically modified biomaterials using factorial and response surface design, *JOURNAL OF ENVIRONMENTAL MANAGEMENT*, Volume: 204, Special Issue: SI, Pages: 839-844, PubMed ID: 28148453, ISSN: 0301-4797, eISSN: 1095-8630, 2017;
91. Gabor, A., Davidescu, C.M., Negrea, A., Ciopec, M., Muntean, C., Negrea, P., Ianasi, C., Butnariu, M. Magnesium silicate doped with environmentally friendly extractants used for rare earth elements adsorption, *DESALINATION AND WATER TREATMENT*, Volume: 63, Pages: 124-134, ISSN: 1944-3994, eISSN: 1944-3986, 2017;

92. Ganea, G., Verebi, I., Marinescu, R. Continuous quality assessment with inCode, SCIENCE OF COMPUTER PROGRAMMING, Volume: 134, Special Issue: SI, Pages: 19-36, ISSN: 0167-6423, eISSN: 1872-7964, 2017;
93. Gheju, M., Balcu, I. Assisted green remediation of chromium pollution, JOURNAL OF ENVIRONMENTAL MANAGEMENT, Volume: 203, Special Issue: SI, Pages: 920-924, Part: 3, PubMed ID: 28479231, ISSN: 0301-4797, eISSN: 1095-8630, 2017;
94. Gheju, M., Balcu, I., Enache, A., Flueraș, A. A kinetic approach on hexavalent chromium removal with metallic iron, JOURNAL OF ENVIRONMENTAL MANAGEMENT, Volume: 203, Special Issue: SI, Pages: 937-941, Part: 3, PubMed ID: 28318824, ISSN: 0301-4797, eISSN: 1095-8630, 2017;
95. Gherhes, V., Obrad, C. Social Responsibility and Ecological Behaviors towards Selective Waste Collection, MATERIALE PLASTICE, Volume: 54, Issue: 3, Pages: 430-432, ISSN: 0025-5289, 2017;
96. Gillich, E.V., Mocan, M., Mituletu, I.C., Korca, Z.I. Process Monitoring in Precision Machining using Optical Sensors, ROMANIAN JOURNAL OF ACOUSTICS AND VIBRATION, Volume: 14, Issue: 1, Pages: 50-53, ISSN: 1584-7284, 2017;
97. Grigore, A., Szuhaneck, C., Onisei, D., Cernescu, A. A Comparative Study Regarding the Deformation Values of Orthodontic Aligners, MATERIALE PLASTICE, Volume: 54, Issue: 3, Pages: 572-573, ISSN: 0025-5289, 2017;
98. Grigorie, A.C., Muntean, C., Vlase, T., Locovei, C., Stefanescu, M. ZnO-SiO<sub>2</sub> based nanocomposites prepared by a modified sol-gel method, MATERIALS CHEMISTRY AND PHYSICS, Volume: 186, Pages: 399-406, ISSN: 0254-0584, eISSN: 1879-3312, 2017;
99. Groza, B., Murvay, S., Van Herrewēge, A., Verbauwhe, I. LiBrA-CAN: Lightweight Broadcast Authentication for Controller Area Networks, ACM TRANSACTIONS ON EMBEDDED COMPUTING SYSTEMS, Volume: 16, Issue: 3, Special Issue: SI, Article Number: 90, ISSN: 1539-9087, eISSN: 1558-3465, 2017;
100. Hadaruga, D.I., Birau, C.L., Gruia, A.T., Paunescu, V., Bandur, G.N., Hadaruga, N.G. Moisture evaluation of beta-cyclodextrin/fish oils complexes by thermal analyses: A data review on common barbel (*Barbus barbus* L.), Pontic shad (*Alosa immaculata* Bennett), European wels catfish (*Silurus glanis* L.), and common bleak (*Alburnus alburnus* L.) living in Danube river, FOOD CHEMISTRY, Volume: 236, Pages: 49-58, PubMed ID: 28624089, ISSN: 0308-8146, eISSN: 1873-7072, 2017;
101. Haidu, D., Negrea, A., Ianasi, C., Antal, D., Sfirloaga, P., Kurunzi, L. CONTRADICTION ASPECTS OF BIOACCUMULATION. ICP-MS, AN APPROACHABLE METHOD FOR ELEMENTAL CHARACTERIZATION OF CROP MEDICINAL PLANTS, DIGEST JOURNAL OF NANOMATERIALS AND BIOSTRUCTURES, Volume: 12, Issue: 2, Pages: 391-400, ISSN: 1842-3582, 2017;
102. Hajaj, T., Talpos, S., Ianes, E., Candea, A., Neagu, A., Szuhaneck, C., Negru, R., Negrutiu, M.L., Sinescu, C. Detecting the Implant in vitro Microleakage Using Spectrophotometry and Neutral Red Dye, REVISTA DE CHIMIE, Volume: 68, Issue: 9, Pages: 2151-2154, ISSN: 0034-7752, 2017;
103. Hatiegan, C., Padureanu, I., Jurcu, M.R., Biriescu, M., Raduca, M., Dilerte, F. The evaluation of the insulation performances of the stator coil for the high power vertical synchronous hydro-generators by monitoring the level of partial discharges, ELECTRICAL ENGINEERING, Volume: 99, Issue: 3, Pages: 1013-1020, ISSN: 0948-7921, eISSN: 1432-0487, 2017;
104. Herban, I.S., Vilceanu, C.B., Grecea, C. Road-Structure Monitoring with Modern Geodetic Technologies, JOURNAL OF SURVEYING ENGINEERING, Volume: 143, Issue: 4, Article Number: 05017004, ISSN: 0733-9453, eISSN: 1943-5428, 2017;
105. Holotescu, C., Gotiu, L.O.L., Andone, D., Cismariu, L., Grosseck, G., Slavici, T. Entrepreneurship Learning Ecosystem for Smart Cities through MOOCs, BRAIN-BROAD RESEARCH IN ARTIFICIAL INTELLIGENCE AND NEUROSCIENCE, Volume: 8, Issue: 2, Pages: 33-43, ISSN: 2067-3957, 2017;
106. Ianos, R., Babuta, R., Pacurariu, C., Lazau, R., Istratie, R., Butaciu, C. Combustion synthesis of ZnAl<sub>2</sub>O<sub>4</sub> powders with tuned surface area, CERAMICS INTERNATIONAL, Volume: 43, Issue: 12, Pages: 8975-8981, ISSN: 0272-8842, eISSN: 1873-3956, 2017;
107. Ianos, R., Muntean, E., Pacurariu, C., Lazau, R., Bandas, C., Delinescu, G. Combustion synthesis of a blue Co-doped zinc aluminate near-infrared reflective pigment, DYES AND PIGMENTS, Volume: 142, Pages: 24-31, ISSN: 0143-7208, eISSN: 1873-3743, 2017;
108. Ianos, R., Muntean, E., Babuta, R., Lazau, R., Pacurariu, C., Bandas, C. Combustion synthesis of pink chromium-doped alumina with excellent near-infrared reflective properties, CERAMICS INTERNATIONAL, Volume: 43, Issue: 2, Pages: 2568-2572, ISSN: 0272-8842, eISSN: 1873-3956, 2017;

109. Iliu, R., Liatsou, I., Savva, I., Vasile, E., Vekas, L., Marinica, O., Mpekris, F., Pashalidis, I., Krasia-Christoforou, T. Magneto-responsive polymer networks as adsorbents for the removal of U (VI) ions from aqueous media, EUROPEAN POLYMER JOURNAL, Volume: 97, Pages: 138-146, ISSN: 0014-3057, eISSN: 1873-1945, 2017;
110. Ionel, I., Makra, L., Bisorca, D., Bodnar, K., Tusnady, G., Calinoiu, D.G., Balogh, R.M., St Lontis, N. METHOD TO DEPICT THE BEST AVAILABLE POSITION, WHEN RELOCATING MONITORING STATIONS, JOURNAL OF ENVIRONMENTAL PROTECTION AND ECOLOGY, Volume: 18, Issue: 1, Pages: 1-9, ISSN: 1311-5065, 2017;
111. Ionescu, D., Kovaci, M. IMPROVING THE DATA STORAGE PERFORMANCES WITH LAYERED NANOWIRES FOR SYNTHETIC ANTIFERROMAGNETIC RACETRACK MEMORIES, ROMANIAN REPORTS IN PHYSICS, Volume: 69, Issue: 1, Article Number: 501, ISSN: 1221-1451, eISSN: 1841-8759, 2017;
112. Istratie, R., Babuta, R., Popa, A., Pacurariu, C., Stoia, M. Enhanced Adsorption of p-Nitrophenol from Aqueous Solutions Using a Functionalized Styrene-Divinylbenzene Copolymer, WATER AIR AND SOIL POLLUTION, Volume: 228, Issue: 8, Article Number: 276, ISSN: 0049-6979, eISSN: 1573-2932, 2017;
113. Ivan, A., Herman, H., Balta, C., Hadaruga, D.I., Mihali, C.V., Ardelean, A., Hermenean, A. Berberis vulgaris extract/beta-cyclodextrin complex increases protection of hepatic cells via suppression of apoptosis and lipogenesis pathways, EXPERIMENTAL AND THERAPEUTIC MEDICINE, Volume: 13, Issue: 5, Pages: 2143-2150, PubMed ID: 28565821, ISSN: 1792-0981, eISSN: 1792-1015, 2017;
114. Jivulescu, M.A., Nechita, I., Gavruta, P. On symmetric decompositions of positive operators, JOURNAL OF PHYSICS A-MATHEMATICAL AND THEORETICAL Volume: 50 Issue: 16 Article Number: 165303, ISSN: 1751-8113, eISSN: 1751-8121, 2017;
115. Keller, A., Chieffo, N., Opritescu, E., Mosoarca, M., Formisano, A. RESILIENCE OF HISTORIC CITIES AND ADAPTATION TO CLIMATE CHANGE, URBANISM ARCHITECTURE CONSTRUCTIONS, Volume: 8, Issue: 1, Pages: 15-26, ISSN: 2069-0509, eISSN: 2069-6469, 2017;
116. Lascu, C., Fajarzadeh, S., Fadali, M.S., Blaabjerg, F. Direct Torque Control With Feedback Linearization for Induction Motor Drives, IEEE TRANSACTIONS ON POWER ELECTRONICS, Volume: 32, Issue: 3, Pages: 2072-2080, ISSN: 0885-8993, eISSN: 1941-0107, 2017;
117. Lazareanu, C. The Real-Valued Maxwell-Bloch Equations with Controls: From a Hamilton-Poisson System to a Chaotic One, INTERNATIONAL JOURNAL OF BIFURCATION AND CHAOS, Volume: 27, Issue: 9, Article Number: 1750143, ISSN: 0218-1274, eISSN: 1793-6551, 2017;
118. Lazareanu, C. On the Hamilton-Poisson realizations of the integrable deformations of the Maxwell-Bloch equations, COMPTES RENDUS MATHÉMATIQUE, Volume: 355, Issue: 5, Pages: 596-600, ISSN: 1631-073X, eISSN: 1778-3569, 2017;
119. Lazareanu, C. Hamilton-Poisson Realizations of the Integrable Deformations of the Rikitake System, ADVANCES IN MATHEMATICAL PHYSICS, Article Number: 4596951, ISSN: 1687-9120, eISSN: 1687-9139, 2017;
120. Lazareanu, C., Binzar, T. Symmetries and Properties of the Energy-Casimir Mapping in the Ball-Plate Problem, ADVANCES IN MATHEMATICAL PHYSICS, Article Number: 5164602, ISSN: 1687-9120, eISSN: 1687-9139, 2017;
121. Lazareanu, C. On a Hamilton-Poisson Approach of the Maxwell-Bloch Equations with a Control, MATHEMATICAL PHYSICS ANALYSIS AND GEOMETRY, Volume: 20, Issue: 3, Article Number: 20, ISSN: 1385-0172, eISSN: 1572-9656, 2017;
122. Lemle, L.D. ON THE APPROXIMATION OF C-0-SEMIGROUPS ON THE DUAL OF A BANACH SPACE, OPERATORS AND MATRICES, Volume: 11, Issue: 4, Pages: 1047-1056, ISSN: 1846-3886, 2017;
123. Linul, E., Serban, D.A., Marsavina, L., Kovacic, J. Low-cycle fatigue behaviour of ductile closed-cell aluminium alloy foam, FATIGUE & FRACTURE OF ENGINEERING MATERIALS & STRUCTURES, Volume: 40, Issue: 4, Pages: 597-604, ISSN: 8756-758X, eISSN: 1460-2695, 2017;
124. Linul, E., Movahedi, N., Marsavina, L. The temperature effect on the axial quasi-static compressive behavior of ex-situ aluminum foam-filled tubes, COMPOSITE STRUCTURES, Volume: 180, Pages: 709-722, ISSN: 0263-8223, eISSN: 1879-1085, 2017;
125. Linul, E., Marsavina, L., Kovacic, J., Sadowski, T. DYNAMIC AND QUASI-STATIC COMPRESSION TESTS OF CLOSED-CELL ALUMINIUM ALLOY FOAMS, PROCEEDINGS OF THE ROMANIAN ACADEMY SERIES A-MATHEMATICS PHYSICS TECHNICAL SCIENCES INFORMATION SCIENCE, Volume: 18, Issue: 4, Pages: 361-369, ISSN: 1454-9069, 2017;
126. Linul, E., Serban, D.A., Marsavina, L., Sadowski, T. Assessment of collapse diagrams of rigid polyurethane foams under dynamic loading conditions, ARCHIVES OF CIVIL AND MECHANICAL ENGINEERING, Volume: 17, Issue: 3, Pages: 457-466, ISSN: 1644-9665, eISSN: 2083-3318, 2017;

127. Linul, E., Marsavina, L., Kovacic, J. Collapse mechanisms of metal foam matrix composites under static and dynamic loading conditions, *MATERIALS SCIENCE AND ENGINEERING A-STRUCTURAL MATERIALS PROPERTIES MICROSTRUCTURE AND PROCESSING*, Volume: 690, Pages: 214-224, ISSN: 0921-5093, eISSN: 1873-4936, 2017;
128. Lontis, N.S., Mihon, N.L., Vetres, I. NUMERICAL SIMULATION STUDY OF A HYBRID ROAD VEHICLE REGARDING FUEL ECONOMY AND AMBIENT EMISSION DELIVERY, *INGINERIA AUTOMOBILULUI*, Issue: 43, Pages: 10-15, ISSN: 1842-4074, 2017;
129. Lovasz, E.C., Margineanu, D.T., Ciupe, V., Maniu, I., Gruescu, C.M., Zabava, E.S., Stan, S.D. Design and control solutions for haptic elbow exoskeleton module used in space telerobotics, *MECHANISM AND MACHINE THEORY*, Volume: 107, Pages: 384-398, ISSN: 0094-114X, 2017;
130. Lupa, L., Popa, A., Dragan, E.S., Ciopec, M., Negrea, A., Negrea, P. Adsorption performance of the organic solid support impregnated with ionic liquid in the removal process of T1(1) from aqueous solutions, *PROCESS SAFETY AND ENVIRONMENTAL PROTECTION*, Volume: 108, Special Issue: SI, Pages: 67-73, ISSN: 0957-5820, eISSN: 1744-3598, 2017;
131. Lupa, N., Popescu, L.H. A complete characterization of exponential stability for discrete dynamics, *JOURNAL OF DIFFERENCE EQUATIONS AND APPLICATIONS*, Volume: 23, Issue: 12, Pages: 2072-2092, ISSN: 1023-6198, eISSN: 1563-5120, 2017;
132. Madescu, G., Biriescu, M., Tutelea, L.N., Mot, M., Svoboda, M., Boldea, I. Experimental Investigation of Rotor Currents Distribution in the Healthy and Faulty Cage of Induction Motors at Standstill, *IEEE TRANSACTIONS ON INDUSTRIAL ELECTRONICS*, Volume: 64, Issue: 7, Pages: 5305-5313, ISSN: 0278-0046, eISSN: 1557-9948, 2017;
133. Maierean, S.M., Serban, M.C., Sahebkar, A., Ursoniu, S., Serban, A., Penson, P., Banach, M. The effects of cinnamon supplementation on blood lipid concentrations: A systematic review and meta-analysis, *JOURNAL OF CLINICAL LIPIDOLOGY*, Volume: 11, Issue: 6, Pages: 1393-1406, PubMed ID: 28887086, ISSN: 1933-2874, eISSN: 1876-4789, 2017;
134. Makra, L., Ionel, I., Bodnar, K., Sumeghy, Z., Tusnady, G. ENVIRONMENTAL OBJECTIVE ANALYSIS, RANKING AND CLUSTERING OF HUNGARIAN CITIES, *JOURNAL OF ENVIRONMENTAL PROTECTION AND ECOLOGY*, Volume: 18, Issue: 1, Pages: 202-224, ISSN: 1311-5065, 2017;
135. Marian, E., Duteanu, N., Vicas, L., Tita, B., Sfirloaga, P., Jurca, T. Purity Determination of Fusidic Acid Using Physico-chemical Methods, *REVISTA DE CHIMIE*, Volume: 68, Issue: 7, Pages: 1435-1437, ISSN: 0034-7752, 2017;
136. Marinca, B., Marinca, V. NEW EXACT AND EXPLICIT SOLUTIONS OF THE ZAKHAROV EQUATIONS AND GENERALIZED ZAKHAROV EQUATIONS BY THE QUOTIENT TRIGONOMETRIC FUNCTION EXPANSION METHOD, *PROCEEDINGS OF THE ROMANIAN ACADEMY SERIES A-MATHEMATICS PHYSICS TECHNICAL SCIENCES INFORMATION SCIENCE*, Volume: 18, Issue: 2, Pages: 166-173, ISSN: 1454-9069, 2017;
137. Marinca, V., Ene, R.D. Optimal homotopy perturbation method for nonlinear differential equations governing MHD Jeffery-Hamel flow with heat transfer problem, *OPEN PHYSICS*, Volume: 15, Issue: 1, Pages: 42-57, ISSN: 2391-5471, 2017;
138. Marinca, V., Ene, R.D., Bereteu, L. Application of the optimal homotopy asymptotic method to nonlinear Bingham fluid dampers, *OPEN PHYSICS*, Volume: 15, Issue: 1, Special Issue: SI, Pages: 620-626, ISSN: 2391-5471, 2017;
139. Marinescu, R., Antoniac, V.I., Stoia, D.I., Liptoiu, D.C. Clavicle anatomical osteosynthesis plate breakage - failure analysis report based on patient morphological parameters, *ROMANIAN JOURNAL OF MORPHOLOGY AND EMBRYOLOGY*, Volume: 58, Issue: 2, Pages: 593-598, PubMed ID: 28730248, ISSN: 1220-0522, 2017;
140. Marinica, O.M. Study of Static Magnetic Properties of Transformer Oil Based Magnetic Fluids for Various Technical Applications Using Demagnetizing Field Correction, *JOURNAL OF NANOMATERIALS*, Article Number: 5407679, ISSN: 1687-4110, eISSN: 1687-4129, 2017;
141. Maris, S., Slavici, T., Nenu, P., Baci, L. Artificial Intelligence as a Decision-making Tool in Planning the Research, *BRAIN-BROAD RESEARCH IN ARTIFICIAL INTELLIGENCE AND NEUROSCIENCE*, Volume: 8, Issue: 3, Pages: 69-76, ISSN: 2067-3957, 2017;
142. Maroiu, A.C., Sinescu, C., Negru, R., Marsavina, L., Bretean, I.D., Duma, V.F., Rominu, M., Bortun, C.M., Negru, M.L. Evaluation of the Adhesion of a Novel Design of Veneers to Dental Materials, *REVISTA DE CHIMIE*, Volume: 68, Issue: 9, Pages: 2125-2128, ISSN: 0034-7752, 2017;
143. Marsavina, L., Berto, F., Negru, R., Serban, D.A., Linul, E. An engineering approach to predict mixed mode fracture of PUR foams based on ASED and micromechanical modelling, *THEORETICAL AND APPLIED FRACTURE MECHANICS*, Volume: 91, Special Issue: SI, Pages: 148-154, ISSN: 0167-8442, eISSN: 1872-7638, 2017;



144. Martian, V., Albetel, S., David, E., Nagi, M. Heat transfer and hydraulic performance models for a family of aluminum plate heat exchanger with transversal offset strip fins, *EXPERIMENTAL HEAT TRANSFER*, Volume: 30, Issue: 6, Pages: 530-543, ISSN: 0891-6152, eISSN: 1521-0480, 2017;
145. Masu, S., Grecu, E., Popa, M., Oncioiu, I. ASPECTS in situ OIL POLLUTED SOIL PHYTOREMEDIATION WITH PASTURE PLANTS, *JOURNAL OF ENVIRONMENTAL PROTECTION AND ECOLOGY*, Volume: 18, Issue: 4, Pages: 1398-1402, ISSN: 1311-5065, 2017;
146. Mazilescu, C.A., Gangloff, B. Value Assigned to Employees Who Preserve the Social and Organizational Environment, *SUSTAINABILITY*, Volume: 9, Issue: 2, Article Number: 170, ISSN: 2071-1050, 2017;
147. Medeleanu, M., Pop, R., Andoni, M., Diudea, M.V. THE INFLUENCE OF AZA-SUBSTITUTION ON THE AROMATICITY OF SUMANENE, *STUDIA UNIVERSITATIS BABES-BOLYAI CHEMIA*, Volume: 62, Issue: 4, Pages: 105-119, ISSN: 1224-7154, 2017;
148. Melita, N.T., Holban, S. dGAsellID: An R Package for Selecting a Variable Number of Features in High Dimensional Data, *R JOURNAL*, Volume: 9, Issue: 2, Pages: 18-34, ISSN: 2073-4859, 2017;
149. Menyhardt, K., Nagy, R. Control Signal Assessment for Vibration Testing Equipment, *JOURNAL OF VIBRATION ENGINEERING & TECHNOLOGIES*, Volume: 5, Issue: 4, Pages: 285-291, ISSN: 2321-3558, 2017;
150. Micea, M.V., Stangaciu, C.S., Stangaciu, V., Curiac, D.I. Novel Hybrid Scheduling Technique for Sensor Nodes with Mixed Criticality Tasks, *SENSORS*, Volume: 17, Issue: 7, Article Number: 1504, ISSN: 1424-8220, 2017;
151. Micu, L.M., Bordeasu, I., Popoviciu, M.O. A New Model for the Equation Describing the Cavitation Mean Depth Erosion Rate Curve, *REVISTA DE CHIMIE*, Volume: 68, Issue: 4, Pages: 894-898, ISSN: 0034-7752, 2017;
152. Mihaicuta, S., Udrescu, M., Topirceanu, A., Udrescu, L. Network science meets respiratory medicine for OSAS phenotyping and severity prediction, *PEERJ*, Volume: 5, Article Number: e3289, PubMed ID: 28503375, ISSN: 2167-8359, 2017;
153. Mihon, N.L., Erdodi, G.M., Lontis, N.S. DIAGNOSIS OF THE UNIT INJECTION PUMP'S ELEMENTS, *INGINERIA AUTOMOBILULUI*, Issue: 42, Pages: 23-26, ISSN: 1842-4074, 2017;
154. Mitelea, I., Bordeasu, I., Varzaru, N., Utu, I.D. Research of the Thermal Gradient and Quality of Welded Joints from PVC Thermoplastics Foils at High Frequency Symmetric Welding, *MATERIALE PLASTICE*, Volume: 54, Issue: 3, Pages: 461-465, ISSN: 0025-5289, 2017;
155. Mitelea, I., Utu, I.D., Urlan, S.D., Craciunescu, C.M. The effect of the solution treatment onto the microstructure and mechanical properties of MAG pulsed welded joints from X2CrNiMoN22-5-3 Duplex stainless steels, *MATERIALWISSENSCHAFT UND WERKSTOFFTECHNIK*, Volume: 48, Issue: 11, Pages: 1040-1048, ISSN: 0933-5137, eISSN: 1521-4052, 2017;
156. Mitelea, I., Bordeasu, I., Katona, S.E., Craciunescu, C.M. Cavitation erosion of 17-4 PH stainless steels following sub-zero treatment, *INTERNATIONAL JOURNAL OF MATERIALS RESEARCH*, Volume: 108, Issue: 12, Pages: 1099-1102, ISSN: 1862-5282, eISSN: 2195-8556, 2017;
157. Mitelea, I., Bordeasu, I., Micu, L.M., Craciunescu, C.M. Microstructure and Cavitation Erosion Resistance of the X2CrNiMoN22-5-3 Duplex Stainless Steel Subjected to Laser Nitriding, *REVISTA DE CHIMIE*, Volume: 68, Issue: 12, Pages: 2992-2996, ISSN: 0034-7752, 2017;
158. Mitelea, I., Utu, I.D., Urlan, S.D., Karanci, O. Microstructure characterization and corrosion testing of MAG pulsed duplex stainless steel welds, *MATERIALS TESTING*, Volume: 59, Issue: 7-8, Pages: 642-646, ISSN: 0025-5300, 2017;
159. Mnerie, C., Preitl, S., Duma, V.F. Galvanometer-Based Scanners: Mathematical Model and Alternative Control Structures for Improved Dynamics and Immunity to Disturbances, *INTERNATIONAL JOURNAL OF STRUCTURAL STABILITY AND DYNAMICS*, Volume: 17, Issue: 5, Special Issue: SI, Article Number: 1740006, ISSN: 0219-4554, eISSN: 1793-6764, 2017;
160. Mocofan, M., Ternauciu, A. TrainCoDe - A study case of the management changes as a result of the lifelong learning, *INTERACTION DESIGN AND ARCHITECTURES*, Issue: 32, Special Issue: SI, Pages: 173-188, ISSN: 1826-9745, eISSN: 2283-2998, 2017;
161. Moga, T.V., Popescu, A., Sporea, I., Danila, M., David, C., Gui, V., Iacob, N., Miclaus, G., Sirli, R. Is Contrast Enhanced Ultrasonography a useful tool in a beginner's hand? How much can a Computer Assisted Diagnosis prototype help in characterizing the malignancy of focal liver lesions?, *MEDICAL ULTRASONOGRAPHY*, Volume: 19, Issue: 3, Pages: 252-258, PubMed ID: 28845489, ISSN: 1844-4172, eISSN: 2066-8643, 2017;

162. Moisa, M.E., Spelmezan, C.G., Paul, C., Bartha-Vari, J.H., Bencz, L.C., Irimie, F.D., Paizs, C., Peter, F., Tosa, M.I. Tailored sol-gel immobilized lipase prepartes for the enzymatic kinetic resolution of heteroaromatic alcohols in batch and continuous flow systems, *RSC ADVANCES*, Volume: 7, Issue: 83, Pages: 52977-52987, ISSN: 2046-2069, 2017;
163. Moro, A.J., Parola, A.J., Pina, F., Pana, A.M., Badea, V., Pausescu, I., Shova, S., Cseh, L. 2,2'-Spirobis[chromene] Derivatives Chemistry and Their Relation with the Multistate System of Anthocyanins, *JOURNAL OF ORGANIC CHEMISTRY*, Volume: 82, Issue: 10, Pages: 5301-5309, PubMed ID: 28441475, ISSN: 0022-3263, 2017;
164. Mosoarca, M., Keller, A.I., Petrus, C., Racolta, A. Failure analysis of historical buildings due to climate change, *ENGINEERING FAILURE ANALYSIS*, Volume: 82, Pages: 666-680, ISSN: 1350-6307, eISSN: 1873-1961, 2017;
165. Movahedi, N., Linul, E. Quasi-static compressive behavior of the ex-situ aluminum-alloy foam-filled tubes under elevated temperature conditions, *MATERIALS LETTERS*, Volume: 206, Pages: 182-184, ISSN: 0167-577X, eISSN: 1873-4979, 2017;
166. Muntean, R., Pascal, D.T., Marginean, G., Vaszilcsin, N. Carbon Nanofibers Decorated with Pt-Co Alloy Nanoparticles as Catalysts for Electrochemical Cell Applications. I. Synthesis and Structural Characterization, *INTERNATIONAL JOURNAL OF ELECTROCHEMICAL SCIENCE*, Volume: 12, Issue: 5, Pages: 4597-4609, ISSN: 1452-3981, 2017;
167. Nagy, Z., Gilia, L., Neagu, C. EXPERIMENTAL INVESTIGATIONS OF COLD-FORMED JOINTS FOR MULTI-STOREY STEEL FRAMED STRUCTURES, *PROCEEDINGS OF THE ROMANIAN ACADEMY SERIES A-MATHEMATICS PHYSICS TECHNICAL SCIENCES INFORMATION SCIENCE*, Volume: 18, Issue: 3, Pages: 256-264, ISSN: 1454-9069, 2017;
168. Nani, V.M. Complex phenomena study in dielectric fluid from gap during the W-EDM processing in ultrasonic field, *INTERNATIONAL JOURNAL OF ADVANCED MANUFACTURING TECHNOLOGY*, Volume: 92, Issue: 1-4, Pages: 197-215, ISSN: 0268-3768, eISSN: 1433-3015, 2017;
169. Nani, V.M. Effect of wire electrode's ultrasonic vibration on erosive capacity to W-EDM machine, *INTERNATIONAL JOURNAL OF ADVANCED MANUFACTURING TECHNOLOGY*, Volume: 88, Issue: 1-4, Pages: 425-441, ISSN: 0268-3768, eISSN: 1433-3015, 2017;
170. Nani, V.M. The ultrasound effect on technological parameters for increase in performances of W-EDM machines, *INTERNATIONAL JOURNAL OF ADVANCED MANUFACTURING TECHNOLOGY*, Volume: 88, Issue: 1-4, Pages: 519-528, ISSN: 0268-3768, eISSN: 1433-3015, 2017;
171. Nani, V.M. Ultrasound influence on the erosive capacity at the electrodischarge processing with ultrasonic activated wire electrode in a single point, *MECCANICA*, Volume: 52, Issue: 6, Pages: 1459-1474, ISSN: 0025-6455, eISSN: 1572-9648, 2017;
172. Nani, V.M., Cires, I. The vibrations' study to the burn gas exhaust fan from a thermoelectric power plant, *APPLIED MATHEMATICAL MODELING*, Volume: 43, Pages: 454-463, ISSN: 0307-904X, eISSN: 1872-8480, 2017;
173. Nanu, S., Ionel, R., Dughir, C., Ionel, I. Automation of a prototype for cutting, sorting and bundling of SRC crops for planting purposes, *MEASUREMENT*, Volume: 95, Pages: 201-209, ISSN: 0263-2241, eISSN: 1873-412X, 2017;
174. Negrea, A., Lupa, L., Ciopec, M., Dragomir, I., Negrea, P. USE OF ZINC ASH FROM GALVANIZATION AS A SOURCE OF ZINC OXIDE, *ENVIRONMENTAL ENGINEERING AND MANAGEMENT JOURNAL*, Volume: 16, Issue: 11, Pages: 2461-2468, ISSN: 1582-9596, eISSN: 1843-3707, 2017;
175. Nicoara, M., Raduta, A., Locovei, C., Buzdugan, D., Stoica, M. About thermostability of biocompatible Ti-Zr-Ta-Si amorphous alloys, *JOURNAL OF THERMAL ANALYSIS AND CALORIMETRY*, Volume: 127, Issue: 1, Pages: 107-113, ISSN: 1388-6150, eISSN: 1588-2926, 2017;
176. Nicoara, M., Locovei, C., Opris, C., Ursu, D., VasIU, R., Stoica, M. Optimizing the parameters for in situ fabrication of hybrid Al-Al<sub>2</sub>O<sub>3</sub> composites, *JOURNAL OF THERMAL ANALYSIS AND CALORIMETRY*, Volume: 127, Issue: 1, Pages: 115-122, ISSN: 1388-6150, eISSN: 1588-2926, 2017;
177. Niyonzima, S., Ilie, S., Pop, N., Mezei, J.Z., Chakrabarti, K., Morel, V., Peres, B., Little, D.A., Hassouni, K., Larson, A., Orel, A.E., Benredjem, D., Bultel, A., Tennyson, J., Reiter, D., Schneider, I.F. Low-energy collisions between electrons and BeH<sup>+</sup>: Cross sections and rate coefficients for all the vibrational states of the ion, *ATOMIC DATA AND NUCLEAR DATA TABLES*, Volume: 115, Pages: 287-308, ISSN: 0092-640X, eISSN: 1090-2090, 2017;
178. Oncioiu, I., Petrescu, A.G., Grecu, E., Petrescu, M. Optimizing the Renewable Energy Potential: Myth or Future Trend in Romania, *ENERGIES*, Volume: 10, Issue: 6, ISSN: 1996-1073, 2017;

179. Orha, C., Pode, R., Manea, F., Lazau, C., Bandas, C. Titanium dioxide-modified activated carbon for advanced drinking water treatment, *PROCESS SAFETY AND ENVIRONMENTAL PROTECTION*, Volume: 108, Special Issue: SI, Pages: 26–33, ISSN: 0957-5820, eISSN: 1744-3598, 2017;
180. Osaci, M., Cacciola, M. Study about the nanoparticle agglomeration in a magnetic nanofluid by the Langevin dynamics simulation model using an effective Verlet-type algorithm, *MICROFLUIDICS AND NANOFUIDICS*, Volume: 21, Issue: 2, Article Number: 19, ISSN: 1613-4982, eISSN: 1613-4990, 2017;
181. Oucif, C., Ouzaa, K., Stoian, V., Descu, C.A. Numerical Modeling of Reinforced Concrete Strengthened Columns Under Cyclic Loading, *ARABIAN JOURNAL FOR SCIENCE AND ENGINEERING*, Volume: 42, Issue: 9, Pages: 3933–3944, ISSN: 2193-567X, eISSN: 2191-4281, 2017;
182. Pacurariu, C., Lazau, I., Lazau, R. Kinetic studies of the dehydroxylation and crystallization of raw kaolinite and fluorides-modified kaolinite, *JOURNAL OF THERMAL ANALYSIS AND CALORIMETRY*, Volume: 127, Issue: 1, Pages: 239–246, ISSN: 1388-6150, eISSN: 1588-2926, 2017;
183. Pana, A.M., Pausescu, I., Shova, S., Badea, V., Tudose, R., Silion, M., Costisor, O., Cseh, L. pH dependent structural interconversion of 2-(2-hydroxy-benzylidene)-cyclohexan-1-one: Crystal structures and spectroscopic investigation, *JOURNAL OF MOLECULAR STRUCTURE*, Volume: 1137, Pages: 9–16, ISSN: 0022-2860, eISSN: 1872-8014, 2017;
184. Pana, A.M., Popa, M., Silion, M., Sfirloaga, P., Bandur, G., Duchatel, L., Rusnac, L.M. Novel semi-interpenetrating network hydrogels based on monosaccharide oligomers with itaconic moiety: synthesis and properties, *IRANIAN POLYMER JOURNAL*, Volume: 26, Issue: 10, Pages: 743–751, ISSN: 1026-1265, eISSN: 1735-5265, 2017;
185. Pascu, A., Stanciu, E.M., Roata, I.C., Hulka, I., Utu, D., Maior, I. INFLUENCE OF THE LASER CLADDING. PARAMETERS AND SOLAR HEAT TREATMENT ON THE PROPERTIES OF BIOCOMPATIBLE INCONEL 718 COATINGS, *REVISTA ROMANA DE MATERIALE-ROMANIAN JOURNAL OF MATERIALS*, Volume: 47, Issue: 2, Pages: 157–165, ISSN: 1583-3186, 2017;
186. Pater, F. SOME INEQUALITIES ON POWER BOUNDED OPERATORS ACTING ON LOCALLY CONVEX SPACES, *JOURNAL OF MATHEMATICAL INEQUALITIES*, Volume: 11, Issue: 2, Pages: 485–494, ISSN: 1846-579X, 2017;
187. Paulescu, M., Pop, N., Stefu, N., Paulescu, E., Boata, R., Calinoiu, D. SEASONAL MODELING OF HOURLY SOLAR IRRADIATION SERIES, *ROMANIAN JOURNAL OF PHYSICS*, Volume: 62, Issue: 7–8, Article Number: 813, ISSN: 1221-146X, 2017;
188. Peron, M., Razavi, S.M.J., Berto, F., Torgersen, J., Marsavina, L. Local strain energy density for the fracture assessment of polyurethane specimens weakened by notches of different shape, *FRATTURA ED INTEGRITA STRUTTURALE*, Issue: 42, Pages: 214–222, ISSN: 1971-8993, 2017;
189. Pop, A., Manea, F., Flueraș, A., Schoonman, J. Simultaneous Voltammetric Detection of Carbaryl and Paraquat Pesticides on Graphene-Modified Boron-Doped Diamond Electrode, *SENSORS*, Volume: 17, Issue: 9, Article Number: 2033, ISSN: 1424-8220, 2017;
190. Pop, A., Baci, A., Wanko, G., Bodor, K., Vlaicu, I., Manea, F. ASSESSMENT OF ELECTROCOAGULATION PROCESS. APPLICATION IN ARSENIC REMOVAL FROM DRINKING WATER, *ENVIRONMENTAL ENGINEERING AND MANAGEMENT JOURNAL*, Volume: 16, Issue: 4, Pages: 821–828, ISSN: 1582-9596, eISSN: 1843-3707, 2017;
191. Popa, M., Glevitzky, I., Dumitrel, G.A., Glevitzky, M., Popa, D. STUDY ON PEROXIDE VALUES FOR DIFFERENT OILS AND FACTORS AFFECTING THE QUALITY OF SUNFLOWER OIL, *SCIENTIFIC PAPERS-SERIES E-LAND RECLAMATION EARTH OBSERVATION & SURVEYING ENVIRONMENTAL ENGINEERING*, Volume: 6, Pages: 137–140, ISSN: 2285-6064, 2017;
192. Popa, S., Boran, S. QUANTITATIVE MEASUREMENT OF THE LEATHER DEGREE OF SWELLING, *STUDIA UNIVERSITATIS BABES-BOLYAI CHEMIA*, Volume: 62, Issue: 4, Pages: 391–396, ISSN: 1224-7154, 2017;
193. Popa, S., Iliescu, S., Iliă, G., Plesu, N., Popa, A., Visa, A., Macarie, L. Solid polymer electrolytes based on phosphorus containing polymers for lithium polymer batteries, *EUROPEAN POLYMER JOURNAL*, Volume: 94, Pages: 286–298, ISSN: 0014-3057, eISSN: 1873-1945, 2017;
194. Popa, S., Boran, S., Simulescu, V. Collagen Films Obtained from Collagen Solutions Characterized by Rheology, *MATERIALE PLASTICE*, Volume: 54, Issue: 2, Pages: 359–361, ISSN: 0025-5289, 2017;
195. Popa, S., Boran, S. CIELAB and Thermal Properties of Sesame Food Oil Under Antocyanin and UV Influence, *REVISTA DE CHIMIE*, Volume: 68, Issue: 6, Pages: 1401–1405, ISSN: 0034-7752, 2017;
196. Popa, S., Boran, S. GLASS PACKING MATERIALS USED FOR INTENSIFICATION OF HEAT TRANSFER AT BOILING ON TUBULAR SURFACES, *THERMAL SCIENCE*, Volume: 21, Issue: 5, Pages: 2031–2037, ISSN: 0354-9836, eISSN: 2334-7163, 2017;



197. Popescu, D., Popescu, C., Dragomirescu, A., Barglazan, M. EXPERIMENTAL INVESTIGATION AND COMPUTATIONAL FLUID DYNAMICS (CFD) ANALYSIS OF AN ECO-FRIENDLY TURBINE, ENVIRONMENTAL ENGINEERING AND MANAGEMENT JOURNAL, Volume: 16, Issue: 4, Pages: 979-988, ISSN: 1582-9596, eISSN: 1843-3707, 2017;
198. Popov, D. ON SOME PROPERTIES OF THE K-COHERENT STATES, PROCEEDINGS OF THE ROMANIAN ACADEMY SERIES A-MATHEMATICS PHYSICS TECHNICAL SCIENCES INFORMATION SCIENCE, Volume: 18, Issue: 4, Pages: 323-330, ISSN: 1454-9069, 2017;
199. Popov, D. A Unitary Coherent States Approach for Linear Spectra, JOURNAL OF ADVANCED PHYSICS, Volume: 6, Issue: 3, Pages: 434-440, ISSN: 2168-1996, eISSN: 2168-2003, 2017;
200. Potra, S.A., Izvercian, M., Pugna, A.P., Dahlgaard, J.J. The HWWP, a refined IVA-Kano model for designing new delightful products or services, TOTAL QUALITY MANAGEMENT & BUSINESS EXCELLENCE, Volume: 28, Issue: 1-2, Pages: 104-117, ISSN: 1478-3363, eISSN: 1478-3371, 2017;
201. Pozna, C., Precup, R.E. On a translated frame-based approach to geometric modeling of robots, ROBOTICS AND AUTONOMOUS SYSTEMS, Volume: 91, Pages: 49-58, ISSN: 0921-8890, eISSN: 1872-793X, 2017;
202. Precup, R.E., Preitl, S., Bojan-Dragos, C.A., Radac, M.B., Szedlak-Stinean, A.I., Hedrea, E.L., Roman, R.C. AUTOMOTIVE APPLICATIONS OF EVOLVING TAKAGI-SUGENO-KANG FUZZY MODELS, FACTA UNIVERSITATIS-SERIES MECHANICAL ENGINEERING, Volume: 15, Issue: 2, Pages: 231-244, ISSN: 0354-2025, eISSN: 2335-0164, 2017;
203. Precup, R.E., David, R.C., Szedlak-Stinean, A.I., Petriu, E.M., Dragan, F. An Easily Understandable Grey Wolf Optimizer and Its Application to Fuzzy Controller Tuning, ALGORITHMS, Volume: 10, Issue: 2, Article Number: 68, ISSN: 1999-4893, 2017;
204. Precup, R.E., Radac, M.B., Roman, R.C., Petriu, E.M. Model-free sliding mode control of nonlinear systems: Algorithms and experiments, INFORMATION SCIENCES, Volume: 381, Pages: 176-192, ISSN: 0020-0255, eISSN: 1872-6291, 2017;
205. Precup, R.E., David, R.C., Petriu, E.M. Grey Wolf Optimizer Algorithm-Based Tuning of Fuzzy Control Systems With Reduced Parametric Sensitivity, IEEE TRANSACTIONS ON INDUSTRIAL ELECTRONICS, Volume: 64, Issue: 1, Pages: 527-534, ISSN: 0278-0046, eISSN: 1557-9948, 2017;
206. Racuciu, M., Iftode, C., Miclaus, S. ULTRAHIGH FREQUENCY-LOW POWER ELECTROMAGNETIC FIELD IMPACT ON PHYSIOLOGICAL PARAMETERS OF TWO TYPES OF CEREALS, ROMANIAN REPORTS IN PHYSICS, Volume: 69, Issue: 4, Article Number: 712, ISSN: 1221-1451, eISSN: 1841-8759, 2017;
207. Radac, M.B., Precup, R.E., Roman, R.C. Model-Free control performance improvement using virtual reference feedback tuning and reinforcement Q-learning, INTERNATIONAL JOURNAL OF SYSTEMS SCIENCE, Volume: 48, Issue: 5, Pages: 1071-1083, ISSN: 0020-7721, eISSN: 1464-5319, 2017;
208. Ramasamy, P., Stoica, M., Bera, S., Calin, M., Eckert, J. Effect of replacing Nb with (Mo and Zr) on glass forming ability, magnetic and mechanical properties of FeCoBSiNb bulk metallic glass, JOURNAL OF ALLOYS AND COMPOUNDS, Volume: 707, Pages: 78-81, ISSN: 0925-8388, eISSN: 1873-4669, 2017;
209. Roman, R.C., Radac, M.B., Precup, R.E., Petriu, E.M. Virtual Reference Feedback Tuning of Model-Free Control Algorithms for Servo Systems, MACHINES, Volume: 5, Issue: 4, Article Number: 25, ISSN: 2075-1702, 2017;
210. Rusu, D., Stratul, S.I., Festila, D., Surlin, P., Kasaj, A., Baderca, F., Boariu, M., Jentsch, H., Locovei, C., Calenic, B. Histology and surface ultrastructure during early healing after gingival augmentation with a three-dimensional collagen matrix: A report of six cases, QUINTESSENCE INTERNATIONAL, Volume: 48, Issue: 1, Pages: 57-67, PubMed ID: 27822571, ISSN: 0033-6572, eISSN: 1936-7163, 2017;
211. Sarac, B., Bernasconi, A., Wright, J., Stoica, M., Spieckermann, F., Muhlbacher, M., Keckes, J., Bian, X., Wang, G., Eckert, J. Structural modifications in sub-T-g annealed CuZr-based metallic glass, MATERIALS SCIENCE AND ENGINEERING A-STRUCTURAL MATERIALS PROPERTIES MICROSTRUCTURE AND PROCESSING, Volume: 707, Pages: 245-252, ISSN: 0921-5093, eISSN: 1873-4936, 2017;
212. Sarac, B., Bera, S., Spieckermann, F., Balakin, S., Stoica, M., Calin, M., Eckert, J. Micropatterning kinetics of different glass-forming systems investigated by thermoplastic net-shaping, SCRIPTA MATERIALIA, Volume: 137, Pages: 127-131, ISSN: 1359-6462, 2017;
213. Sarac, B., Bera, S., Balakin, S., Stoica, M., Calin, M., Eckert, J. Hierarchical surface patterning of Ni- and Be-free Ti- and Zr-based bulk metallic glasses by thermoplastic net-shaping, MATERIALS SCIENCE & ENGINEERING C-MATERIALS FOR BIOLOGICAL APPLICATIONS, Volume: 73, Pages: 398-405, PubMed ID: 28183624, ISSN: 0928-4931, eISSN: 1873-0191, 2017;

214. Sarbu, I., Iosif, A. Numerical Simulation of the Laminar Forced Convective Heat Transfer between Two Concentric Cylinders, *COMPUTATION*, Volume: 5, Issue: 2, Article Number: 25, ISSN: 2079-3197, 2017;
215. Sinescu, C., Bradu, A., Duma, V.F., Topala, F., Negrutiu, M., Podoleanu, A.G. Effects of Temperature Variations during Sintering of Metal Ceramic Tooth Prostheses Investigated Non-Destructively with Optical Coherence Tomography, *APPLIED SCIENCES-BASEL*, Volume: 7, Issue: 6, Article Number: 552, ISSN: 2076-3417, 2017;
216. Socalici, A., Ardelean, E., Pascu, L., Putan, V. Friction and Wear Behaviour of Composite Materials Containing Organic Components, *MATERIALE PLASTICE*, Volume: 54, Issue: 2, Pages: 269-273, ISSN: 0025-5289, 2017;
217. Stefan, D., Rudolf, P., Muntean, S., Susan-Resiga, R. Proper Orthogonal Decomposition of Self-Induced Instabilities in Decelerated Swirling Flows and Their Mitigation Through Axial Water Injection, *JOURNAL OF FLUIDS ENGINEERING-TRANSACTIONS OF THE ASME*, Volume: 139, Issue: 8, Article Number: 081101, ISSN: 0098-2202, eISSN: 1528-901X, 2017;
218. Stefanu, M.N., Cata, A., Rosu, D., Milea, M., Ienascu, I.M.C. NANO-HYDROXYAPATITE COMPOSITES FOR DENTAL USE, *REVUE ROUMAINE DE CHIMIE*, Volume: 62, Issue: 6-7, Pages: 481-487, 3rd International Conference on Analytical Chemistry (RO-ICAC), AUG 28-31, 2016, Iasi, ROMANIA, ISSN: 0035-3930, Published: 2017;
219. Stefu, N., Paulescu, M., Gravila, P., Paulescu, E., Pop, N., Boata, R. MODEL FOR THE UV BIOLOGICALLY EFFECTIVE DOSE AND APPLICATION UNDER FUTURE CLIMATE CONDITIONS, *ENVIRONMENTAL ENGINEERING AND MANAGEMENT JOURNAL*, Volume: 16, Issue: 1, Pages: 225-234, ISSN: 1582-9596, eISSN: 1843-3707, 2017;
220. Stoia, M., Muntean, E., Pacurariu, C., Mihali, C. Thermal behavior of MnFe<sub>2</sub>O<sub>4</sub> and MnFe<sub>2</sub>O<sub>4</sub>/C nanocomposite synthesized by a solvothermal method, *THERMOCHIMICA ACTA*, Volume: 652, Pages: 1-8, ISSN: 0040-6031, eISSN: 1872-762X, 2017;
221. Stoia, M., Muntean, C., Militaru, B. MnFe<sub>2</sub>O<sub>4</sub> nanoparticles as new catalyst for oxidative degradation of phenol by peroxydisulfate, *JOURNAL OF ENVIRONMENTAL SCIENCES*, Volume: 53, Pages: 269-277, PubMed ID: 28372751, ISSN: 1001-0742, eISSN: 1878-7320, 2017;
222. Stoia, M., Barvinschi, P., Barbu-Tudoran, L., Bunoiu, M. Influence of polyols on the formation of nanocrystalline nickel ferrite inside silica matrices, *JOURNAL OF CRYSTAL GROWTH*, Volume: 457, Special Issue: SI, Pages: 294-301, ISSN: 0022-0248, eISSN: 1873-5002, 2017;
223. Stoia, M., Pacurariu, C., Muntean, E.C., Thermal stability of the solvothermal-synthesized MnFe<sub>2</sub>O<sub>4</sub> nanopowder, *JOURNAL OF THERMAL ANALYSIS AND CALORIMETRY*, Volume: 127, Issue: 1, Pages: 155-162, ISSN: 1388-6150, eISSN: 1588-2926, 2017;
224. Susan-Resiga, D., Vekas, L. Ferrofluid based composite fluids: Magnetorheological properties correlated by Mason and Casson numbers, *JOURNAL OF RHEOLOGY*, Volume: 61, Issue: 3, Pages: 401-408, ISSN: 0148-6055, 2017;
225. Suta, L.M., Tudor, A., Sandulovici, C.R., Stelea, L., Hadaruga, D., Mircioiu, C., Balint, G.S. Multivariate Statistical Analysis Regarding the Formulation of Oxicam-Based Pharmaceutical Hydrogels, *REVISTA DE CHIMIE*, Volume: 68, Issue: 4, Pages: 726-731, ISSN: 0034-7752, 2017;
226. Szerb, E.I., Cseh, L., Pana, A.M., Banica, R., Linul, P., Lazarovici, M., Cretu, C., Demetrovici, L., Locovei, C., Simu, G.M., Strimbeanu, N., Costisor, O. SYNTHESIS AND CHARACTERIZATION OF COPPER NANOCUBES FROM WASTE COMPLEX CATALYST, *REVUE ROUMAINE DE CHIMIE*, Volume: 62, Issue: 4-5, Pages: 433-438, ISSN: 0035-3930, 2017;
227. Tenescu, A., Precup, R.E., Minculete, N. Evolving Fuzzy Models for Automated Translation, *ACTA POLYTECHNICA HUNGARICA*, Volume: 14, Issue: 2, Pages: 27-46, ISSN: 1785-8860, 2017;
228. Tigan, G., Llibre, J., Ciurdariu, L. Degenerate Fold-Hopf Bifurcations in a Rossler-Type System, *INTERNATIONAL JOURNAL OF BIFURCATION AND CHAOS*, Volume: 27, Issue: 5, Article Number: 1750068, ISSN: 0218-1274, eISSN: 1793-6551, 2017;
229. Tigan, G. DEGENERATE WITH RESPECT TO PARAMETERS FOLD-HOPF BIFURCATIONS, *DISCRETE AND CONTINUOUS DYNAMICAL SYSTEMS*, Volume: 37, Issue: 4, Pages: 2115-2140, ISSN: 1078-0947, eISSN: 1553-5231, 2017;
230. Tigan, G. Using Melnikov functions of any order for studying limit cycles, *JOURNAL OF MATHEMATICAL ANALYSIS AND APPLICATIONS*, Volume: 448, Issue: 1, Pages: 409-420, ISSN: 0022-247X, eISSN: 1096-0813, 2017;
231. Tiwari, A.K., Albulescu, C.T., Yoon, S.M. A multifractal detrended fluctuation analysis of financial market efficiency: Comparison using Dow Jones sector ETF indices, *PHYSICA A-STATISTICAL MECHANICS AND ITS APPLICATIONS*, Volume: 483, Pages: 182-192, ISSN: 0378-4371, eISSN: 1873-2119, 2017;

232. Topirceanu, A. Breaking up friendships in exams: A case study for minimizing student cheating in higher education using social network analysis, *COMPUTERS & EDUCATION*, Volume: 115, Pages: 171-187, ISSN: 0360-1315, eISSN: 1873-782X, 2017;
233. Topirceanu, A., Udrescu, M. Statistical fidelity: a tool to quantify the similarity between multi-variable entities with application in complex networks, *INTERNATIONAL JOURNAL OF COMPUTER MATHEMATICS*, Volume: 94, Issue: 9, Pages: 1787-1805, ISSN: 0020-7160, eISSN: 1029-0265, 2017;
234. Totorean, A.F., Hudrea, C.I., Bosioc, A.I., Bernad, S.I. FLOW FIELD EVOLUTION IN STENTED VERSUS STENOSED CORONARY ARTERY, *PROCEEDINGS OF THE ROMANIAN ACADEMY SERIES A-MATHEMATICS PHYSICS TECHNICAL SCIENCES INFORMATION SCIENCE*, Volume: 18, Issue: 3, Pages: 248-255, ISSN: 1454-9069, 2017;
235. Tudoran, R.M., Girban, A. Bifurcations of limit cycles of perturbed completely integrable systems, *NONLINEARITY*, Volume: 30, Issue: 3, Pages: 1058-1088, ISSN: 0951-7715, eISSN: 1361-6544, 2017;
236. Ungurean, L., Carstoiu, G., Micea, M.V., Groza, V. Battery state of health estimation: a structured review of models, methods and commercial devices, *INTERNATIONAL JOURNAL OF ENERGY RESEARCH*, Volume: 41, Issue: 2, Pages: 151-181, ISSN: 0363-907X, eISSN: 1099-114X, 2017;
237. Urechescu, H., Pricop, M., Pricop, C., Mateas, M., Natanael, S., Galatanu, S.V. Thermoplastic Materials Used for Fabrication of Maxillary Obturator Prostheses Experimental compression and traction tests, *MATERIALE PLASTICE*, Volume: 54, Issue: 3, Pages: 477-480, ISSN: 0025-5289, 2017;
238. Utu, I.D., Marginean, G. Effect of electron beam remelting on the characteristics of HVOF sprayed Al<sub>2</sub>O<sub>3</sub>-TiO<sub>2</sub> coatings deposited on titanium substrate, *COLLOIDS AND SURFACES A-PHYSICO-CHEMICAL AND ENGINEERING ASPECTS*, Volume: 526, Special Issue: SI, Pages: 70-75, ISSN: 0927-7757, eISSN: 1873-4359, 2017;
239. Vaduva, A.O., Glameanu, C., Negrea, R., Muntean, M.D., Dema, A.L.C. In vivo confocal microscopy quantification of reactive oxygen species: a working model in rat kidney, *ROMANIAN JOURNAL OF MORPHOLOGY AND EMBRYOLOGY*, Volume: 58, Issue: 3, Pages: 953-960, PubMed ID: 29250674, ISSN: 1220-0522, 2017;
240. Vancea, C., Gheju, M., Mosoarca, G. INERTIZATION IN VITREOUS MATRIX OF EXHAUSTED REACTIVE MIXTURES RESULTED FROM THE REMOVAL OF Cr(VI) WITH Fe-0 IN CONTINUOUS-FLOW SYSTEM, *REVISTA ROMANA DE MATERIALE-ROMANIAN JOURNAL OF MATERIALS*, Volume: 47, Issue: 4, Pages: 435-441, ISSN: 1583-3186, 2017;
241. Vasilevska, D., Rivza, B., Bogdan, R. Evaluation of Readiness for Distance Education of Students in European Universities, *BRAIN-BROAD RESEARCH IN ARTIFICIAL INTELLIGENCE AND NEUROSCIENCE*, Volume: 8, Issue: 1, Pages: 35-41, ISSN: 2067-3957, 2017;
242. Vaszilcsin, N., Vaireanu, D.I. Could one achieve a self-recharging double layer capacitor?, *BULGARIAN CHEMICAL COMMUNICATIONS*, Volume: 49, Special Issue: C, Pages: 263-269, ISSN: 0324-1130, 2017;
243. Vintila, T., Gherman, V.D., Popa, N., Popescu, D., Buzatu, C., Motoc, M. Influence of Enzymatic Cocktails on Conversion of Agricultural Lignocellulose to Fermentable Sugars, *REVISTA DE CHIMIE*, Volume: 68, Issue: 2, Pages: 373-377, ISSN: 0034-7752, 2017;
244. Vlazan, P., Stoia, M., Poienu, M., Sfirloaga, P. Phase transition behaviour and physicochemical properties of KNbO<sub>3</sub> ceramics, *CERAMICS INTERNATIONAL*, Volume: 43, Issue: 8, Pages: 5963-5967, ISSN: 0272-8842, eISSN: 1873-3956, 2017;
245. Vulcu, C., Stratan, A., Ciutina, A., Dubina, D. Beam-to-CFT High-Strength Joints with External Diaphragm. II: Numerical Simulation of Joint Behavior, *JOURNAL OF STRUCTURAL ENGINEERING*, Volume: 143, Issue: 5, Article Number: 04017002, ISSN: 0733-9445, eISSN: 1943-541X, 2017;
246. Vulcu, C., Stratan, A., Ciutina, A., Dubina, D. Beam-to-CFT High-Strength Joints with External Diaphragm. I: Design and Experimental Validation, *JOURNAL OF STRUCTURAL ENGINEERING*, Volume: 143, Issue: 5, Article Number: 04017001, ISSN: 0733-9445, eISSN: 1943-541X, 2017;
247. Xydis, G., Mihet-Popa, L. Wind energy integration via residential appliances, *ENERGY EFFICIENCY*, Volume: 10, Issue: 2, Pages: 319-329, ISSN: 1570-646X, eISSN: 1570-6478, 2017;

248. Zhang, L., He, Z.Y., Tan, J., Zhang, Y.Q., Stoica, M., Calin, M., Prashanth, K.G., Cordill, M.J., Jiang, Y.H., Zhou, R., Eckert, J. Designing a novel functional-structural NiTi/hydroxyapatite composite with enhanced mechanical properties and high bioactivity, INTERMETALLICS, Volume: 84, Pages: 35-41, ISSN: 0966-9795, eISSN: 1879-0216, 2017;
249. Zhang, L., He, Z.Y., Tan, J., Zhang, Y.Q., Stoica, M., Prashanth, K.G., Cordill, M.J., Jiang, Y.H., Zhou, R., Eckert, J. Rapid fabrication of function-structure-integrated NiTi alloys: Towards a combination of excellent superelasticity and favorable bioactivity, INTERMETALLICS, Volume: 82, Pages: 1-13, ISSN: 0966-9795, eISSN: 1879-0216, 2017;
250. Zhong, J.Y., Zhang, L.M., Tigan, G. Bifurcations of a discrete-time neuron model, JOURNAL OF DIFFERENCE EQUATIONS AND APPLICATIONS, Volume: 23, Issue: 9, Pages: 1508-1528, ISSN: 1023-6198, eISSN: 1563-5120, 2017;
251. Zhou, Z.M., Tigan, G., Yu, Z.H. Hopf bifurcations in an extended Lorenz system, ADVANCES IN DIFFERENCE EQUATIONS, Article Number: 28, ISSN: 1687-1847, 2017.



# Papers in ISI Proceedings



1. Abrudean, C. Simulation of electrical and thermal fields in a multimode microwave oven using software written in C plus, INNOVATIVE IDEAS IN SCIENCE 2016, Book Series: IOP Conference Series–Materials Science and Engineering, Volume: 200, Article Number: UNSP 012053, Conference on Innovative Ideas in Science, NOV 10–11, 2016, Baia Mare, ROMANIA, ISSN: 1757-8981, Published: 2017;
2. Alexa, V., Ratiu, S.A., Kiss, I., Cioata, V.G. Modelling pressure rolling of asymmetric rolling process, INNOVATIVE IDEAS IN SCIENCE 2016, Book Series: IOP Conference Series–Materials Science and Engineering, Volume: 200, Article Number: UNSP 012038, Conference on Innovative Ideas in Science, NOV 10–11, 2016, Baia Mare, ROMANIA, ISSN: 1757-8981, Published: 2017;
3. Alexa, V., Ratiu, S.A., Kiss, I., Cioata, C.G. Research on the rolling moment in the symmetrical and asymmetrical rolling process, INTERNATIONAL CONFERENCE ON APPLIED SCIENCES (ICAS2016), Book Series: IOP Conference Series–Materials Science and Engineering, Volume: 163, Article Number: UNSP 012047, International Conference on Applied Sciences (ICAS), MAY 25–27, 2016, Hunedoara, ROMANIA, ISSN: 1757-8981, Published: 2017;
4. Alionescu, A., Bala, A.C., Brebu, F.M., Moscovici, A.M. Creating 3D Models of Historical Buildings Using Geospatial Data, PROCEEDINGS OF THE INTERNATIONAL CONFERENCE ON NUMERICAL ANALYSIS AND APPLIED MATHEMATICS 2016 (ICNAAM–2016), Book Series: AIP Conference Proceedings, Volume: 1863, Article Number: UNSP 430002–1, International Conference on Numerical Analysis and Applied Mathematics (ICNAAM), SEP 19–25, 2016, Rhodes, GREECE, ISSN: 0094-243X, ISBN: 978-0-7354-1538-6, Published: 2017;
5. Ambrus, R., Izvercian, M., Ivascu, L., Artene, A. THE LINK BETWEEN COMPETITIVENESS AND SUSTAINABILITY OF ENTERPRISES, 4TH BECI INTERNATIONAL CONFERENCE ON BUSINESS AND ECONOMICS 2017, Book Series: European Proceedings of Multidisciplinary Sciences, Volume: 1, Pages: 39–47, 4th International Conference on Business and Economics (BE-ci), JUN 05–07, 2017, Brno, CZECH REPUBLIC, ISSN: 2421-826X, Published: 2017;
6. Ambrus, R., Izvercian, M., Artene, A., Ivascu, L. REGENERATIVE MANAGEMENT ACCOUNTING IN THE CONTEXT OF CIRCULAR ECONOMY, 4TH BECI INTERNATIONAL CONFERENCE ON BUSINESS AND ECONOMICS 2017, Book Series: European Proceedings of Multidisciplinary Sciences, Volume: 1, Pages: 59–65, 4th International Conference on Business and Economics (BE-ci), JUN 05–07, 2017, Brno, CZECH REPUBLIC, ISSN: 2421-826X, Published: 2017;
7. Ancuti, C.O., Ancuti, C., De Vleeschouwer, C., Garcia, R. Locally Adaptive Color Correction for Underwater Image Dehazing and Matching, 2017 IEEE CONFERENCE ON COMPUTER VISION AND PATTERN RECOGNITION WORKSHOPS (CVPRW), Book Series: IEEE Computer Society Conference on Computer Vision and Pattern Recognition Workshops, Pages: 997–1005, 30th IEEE/CVF Conference on Computer Vision and Pattern Recognition Workshops (CVPRW), Honolulu, HI, ISSN: 2160-7508, ISBN: 978-1-5386-0733-6, Published: 2017;
8. Ancuti, C.O., Ancuti, C., De Vleeschouwer, C., Neumann, L., Garcia, R. COLOR TRANSFER FOR UNDERWATER DEHAZING AND DEPTH ESTIMATION, 2017 24TH IEEE INTERNATIONAL CONFERENCE ON IMAGE PROCESSING (ICIP), Book Series: IEEE International Conference on Image Processing ICIP, Pages: 695–699, 24th IEEE International Conference on Image Processing (ICIP), SEP 17–20, 2017, Beijing, PEOPLES R CHINA, ISSN: 1522-4880, ISBN: 978-1-5090-2175-8, Published: 2017;
9. Andone, D., Ternauciu, A., Vasii, R. Using Open Education Tools for a Higher Education Virtual Campus, 2017 IEEE 17TH INTERNATIONAL CONFERENCE ON ADVANCED LEARNING TECHNOLOGIES (ICALT), Book Series: IEEE International Conference on Advanced Learning Technologies, Pages: 26–30, 17th IEEE International Conference on Advanced Learning Technologies (ICALT), JUL 03–07, 2017, Timisoara, ROMANIA, ISSN: 2161-3761, ISBN: 978-1-5386-3870-5, Published: 2017;
10. Andone, D., Vasii, R., Ternauciu, A. UniCampus: the First Courses in a Romanian MOOC, PROCEEDINGS OF 2017 IEEE GLOBAL ENGINEERING EDUCATION CONFERENCE (EDUCON2017), Book Series: IEEE Global Engineering Education Conference, Pages: 1210–1214, 8th IEEE Global Engineering Education Conference (EDUCON), APR 25–28, 2017, Athens, GREECE, ISSN: 2165-9567, ISBN: 978-1-5090-5467-1, Published: 2017;
11. Apostol, I., Mosoarca, M., Stoian, V. Modern Consolidation Solutions for Buildings with Historical Value. Part I: Reinforced Concrete Structures, MODERN TECHNOLOGIES FOR THE 3RD MILLENNIUM, Pages: 111–116, 16th National Technical-Scientific Conference on Modern Technologies for the 3rd Millennium, MAR 23–24, 2017, Oradea, ROMANIA, ISBN: 978-88-87729-41-2, Published: 2017;
12. Ardelean, E., Socalici, A., Ardelean, M., Serban, S., Vatasescu, M. The analysis of the steel deoxidation process in a vacuum installation, INTERNATIONAL CONFERENCE ON APPLIED SCIENCES (ICAS2016), Book Series: IOP Conference Series–Materials Science and Engineering, Volume: 163, Article Number: UNSP 012025, International Conference on Applied Sciences (ICAS), MAY 25–27, 2016, Hunedoara, ROMANIA, ISSN: 1757-8981, Published: 2017;



13. Armas, A., Beilicci, R., Beilicci, E. Numerical Limitations of 1D Hydraulic Models Using MIKE11 or HEC-RAS software – Case study of Baraolt River, Romania, WORLD MULTIDISCIPLINARY CIVIL ENGINEERING-ARCHITECTURE-URBAN PLANNING SYMPOSIUM – WMCAUS, Book Series: IOP Conference Series-Materials Science and Engineering, Volume: 245, Article Number: UNSP 072010, World Multidisciplinary Civil Engineering-Architecture-Urban Planning Symposium (WMCAUS), JUN 12-16, 2017, Prague, CZECH REPUBLIC, ISSN: 1757-8981, Published: 2017;
14. Avram, S., Plotenco, V., Paven, L.N. Design and Development of an Electricity Meter Test Equipment, 2017 INTERNATIONAL CONFERENCE ON OPTIMIZATION OF ELECTRICAL AND ELECTRONIC EQUIPMENT (OPTIM) & 2017 INTL AEGEAN CONFERENCE ON ELECTRICAL MACHINES AND POWER ELECTRONICS (ACEMP), Pages: 96-101, International Conference on Optimization of Electrical and Electronic Equipment (OPTIM) / Intl Aegean Conference on Electrical Machines and Power Electronics (ACEMP), MAY 25-27, 2017, Brasov, ROMANIA, ISBN: 978-1-5090-4489-4, Published: 2017;
15. Avram, S., Safta, A.M., Căleanu, C.D., Vasiu, R. Hardware and Software Implementation of an Embedded Metering Webserver, 2017 40TH INTERNATIONAL CONFERENCE ON TELECOMMUNICATIONS AND SIGNAL PROCESSING (TSP), Pages: 43-46, 40th International Conference on Telecommunications and Signal Processing (TSP), JUL 05-07, 2017, Barcelona, SPAIN, ISBN: 978-1-5090-3982-1, Published: 2017;
16. Băciu, I., Cuntan, C.D. Single-phase frequency converter, INTERNATIONAL CONFERENCE ON APPLIED SCIENCES (ICAS2016), Book Series: IOP Conference Series-Materials Science and Engineering, Volume: 163, Article Number: UNSP 012036, International Conference on Applied Sciences (ICAS), MAY 25-27, 2016, Hunedoara, ROMANIA, ISSN: 1757-8981, Published: 2017;
17. Băciu, I., Ghiormez, L., Vasar, C. Study for the electric arc of alternative current at the single phase welding machine using the Matlab/Simulink environment, INTERNATIONAL CONFERENCE ON APPLIED SCIENCES (ICAS2016), Book Series: IOP Conference Series-Materials Science and Engineering, Volume: 163, Article Number: UNSP 012027, International Conference on Applied Sciences (ICAS), MAY 25-27, 2016, Hunedoara, ROMANIA, ISSN: 1757-8981, Published: 2017;
18. Bădea, A., Prostean, G., Tamasila, M., Vartosu, A. Collaborative decision-making on wind power projects based on AHP method, INTERNATIONAL CONFERENCE ON APPLIED SCIENCES (ICAS2016), Book Series: IOP Conference Series-Materials Science and Engineering, Volume: 163, Article Number: UNSP 012017, International Conference on Applied Sciences (ICAS), MAY 25-27, 2016, Hunedoara, ROMANIA, ISSN: 1757-8981, Published: 2017;
19. Balaj, C.I., Man, T.E., Paulescu, M. Performance Assessment of a Direct-Coupled PV Water Pumping System, TIM15-16 PHYSICS CONFERENCE, Book Series: AIP Conference Proceedings, Volume: 1796, Article Number: UNSP 040012, TIM15-16 Physics Conference, MAY 26-28, 2016, Timisoara, ROMANIA, ISSN: 0094-243X, ISBN: 978-0-7354-1462-4, Published: 2017;
20. Balint, C., De Sabata, A., Bechet, P., Miclaus, S. Joint Spectrum Availability Measurement in the 4.5-10.5 MHz HF Band, 2017 14TH INTERNATIONAL CONFERENCE ON ENGINEERING OF MODERN ELECTRIC SYSTEMS (EMES), Pages: 232-235, 14th International Conference on Engineering of Modern Electric Systems (EMES), JUN 01-02, 2017, ORADEA, ROMANIA, ISBN: 978-1-5090-6073-3, Published: 2017;
21. Baloi, M.A. Probability of Fermion Pair Production in External Electric Field, TIM17 PHYSICS CONFERENCE, Book Series: AIP Conference Proceedings, Volume: 1916, Article Number: UNSP 020012, 17th Physics Conference, MAY 25-27, 2017, Timisoara, ROMANIA, ISSN: 0094-243X, ISBN: 978-0-7354-1608-6, Published: 2017;
22. Banciu, F.V. An approach to support entries for a design failure modes and effects analysis, 4TH INTERNATIONAL CONFERENCE ON COMPUTING AND SOLUTIONS IN MANUFACTURING ENGINEERING 2016 - COSME'16, Book Series: MATEC Web of Conferences, Volume: 94, Article Number: UNSP 05001, 4th International Conference on Computing and Solutions in Manufacturing Engineering (CoSME), NOV 03-04, 2016, Brasov, ROMANIA, ISSN: 2261-236X, Published: 2017;
23. Barna, L., Lelea, D. The Influence of Magnetic Field on Low Pressure Injection of Oxyhydrogen in Turbocharged Compression Ignition Engines, 10TH INTERNATIONAL CONFERENCE INTERDISCIPLINARITY IN ENGINEERING, INTER-ENG 2016, Book Series: Procedia Engineering, Volume: 181, Pages: 718-724, 10th International Conference on Interdisciplinarity in Engineering (INTER-ENG), OCT 06-07, 2016, Tirgu Mures, ROMANIA, ISSN: 1877-7058, Published: 2017;
24. Barz, C., Latinovic, T., Deaconu, S., Preradovic, D., Pop, P.P., Pop-Vadean, A. Using Moeller PLC in automation of an artesian fountains, INTERNATIONAL CONFERENCE ON APPLIED SCIENCES (ICAS2016), Book Series: IOP Conference Series-Materials Science and Engineering, Volume: 163, Article Number: UNSP 012052, International Conference on Applied Sciences (ICAS), MAY 25-27, 2016, Hunedoara, ROMANIA, ISSN: 1757-8981, Published: 2017;

25. Beiu, V., Daus, L., Rohatinovici, N.O.C., Balas, V.E. Transport Reliability on Axonal Cytoskeleton, 2017 14TH INTERNATIONAL CONFERENCE ON ENGINEERING OF MODERN ELECTRIC SYSTEMS (EMES), Pages: 160-163, 14th International Conference on Engineering of Modern Electric Systems (EMES), JUN 01-02, 2017, ORADEA, ROMANIA, ISBN: 978-1-5090-6073-3, Published: 2017;
26. Belega, D., Petri, D., Dallet, D. A Frequency-Domain Linear Least-Squares Approach for Complex Sine-wave Amplitude and Phase Estimation, 2017 IEEE INTERNATIONAL INSTRUMENTATION AND MEASUREMENT TECHNOLOGY CONFERENCE (I2MTC), Pages: 105-110, IEEE International Instrumentation and Measurement Technology Conference (I2MTC), MAY 22-27, 2017, Torino, ITALY, ISBN: 978-1-5090-3596-0, Published: 2017;
27. Belgiu, G., Carasu, C., Serban, D., Turc, C.G. Product management of making large pieces through Rapid Prototyping PolyJet((R)) technology, MODTECH INTERNATIONAL CONFERENCE - MODERN TECHNOLOGIES IN INDUSTRIAL ENGINEERING V, Book Series: IOP Conference Series-Materials Science and Engineering, Volume: 227, Article Number: UNSP 012015, 5th International Conference on Modern Technologies in Industrial Engineering (ModTech), JUN 14-17, 2017, Sibiu, ROMANIA, ISSN: 1757-8981, Published: 2017;
28. Bena, T., Mitelea, I., Bordeasu, I., Utu, I.D., Craciunescu, C.M. THE QUENCHING - TEMPERING HEAT TREATMENT AND CAVITATION EROSION RESISTANCE OF NODULAR CAST IRON WITH FERRITE - PEARLITE MICROSTRUCTURE, METAL 2017: 26TH INTERNATIONAL CONFERENCE ON METALLURGY AND MATERIALS, Pages: 731-736, 26th International Conference on Metallurgy and Materials (METAL), MAY 24-26, 2017, Brno, CZECH REPUBLIC, ISBN: 978-80-87294-79-6, Published: 2017;
29. Benea, L.M. Capture and storage of Carbon dioxide: a method for countering climatic changes, INTERNATIONAL CONFERENCE ON APPLIED SCIENCES (ICAS2016), Book Series: IOP Conference Series-Materials Science and Engineering, Volume: 163, Article Number: UNSP 012045, International Conference on Applied Sciences (ICAS), MAY 25-27, 2016, Hunedoara, ROMANIA, ISSN: 1757-8981, Published: 2017;
30. Berdie, A.D., Osaci, M., Muscalagiu, I., Barz, C. A combined approach of AHP and TOPSIS methods applied in the field of integrated software systems, INNOVATIVE IDEAS IN SCIENCE 2016, Book Series: IOP Conference Series-Materials Science and Engineering, Volume: 200, Article Number: UNSP 012041, Conference on Innovative Ideas in Science, NOV 10-11, 2016, Baia Mare, ROMANIA, ISSN: 1757-8981, Published: 2017;
31. Berghian, A.B., Vasiu, T., Abrudean, C. Experiments assigned to determine the acceleration of 8000kN shear laboratory model elements, INTERNATIONAL CONFERENCE ON APPLIED SCIENCES (ICAS2016), Book Series: IOP Conference Series-Materials Science and Engineering, Volume: 163, Article Number: UNSP 012021, International Conference on Applied Sciences (ICAS), MAY 25-27, 2016, Hunedoara, ROMANIA, ISSN: 1757-8981, Published: 2017;
32. Bernad, E., Bernad, S., Petre, I. Ultrasound Evaluation of the Umbilical Artery Blood Flow, 13TH CONFERENCE OF THE ROMANIAN-GERMAN SOCIETY OF OBSTETRICS AND GYNECOLOGY, Pages: 39-43, 13th Conference of the Romanian-German-Society-of-Obstetrics-and-Gynecology, SEP 14-16, 2017, Timisoara, ROMANIA, ISBN: 978-88-95922-95-9, Published: 2017;
33. Bernad, I.S., Moza, A., Petre, I., Bernad, E. Hemodynamic Evaluation of the Umbilical Cord, 13TH CONFERENCE OF THE ROMANIAN-GERMAN SOCIETY OF OBSTETRICS AND GYNECOLOGY, Pages: 49-53, 13th Conference of the Romanian-German-Society-of-Obstetrics-and-Gynecology, SEP 14-16, 2017, Timisoara, ROMANIA, ISBN: 978-88-95922-95-9, Published: 2017;
34. Bernad, I.S., Moza, A., Craina, M., Bernad, S.E. Antenatal Ultrasound Umbilical Cord Coiling Evaluation, 5TH ROMANIAN CONGRESS OF THE ROMANIAN SOCIETY OF ULTRASOUND IN OBSTETRICS AND GYNECOLOGY, Pages: 73-77, 5th Romanian Congress of the Romanian-Society-of-Ultrasound-in-Obstetrics-and-Gynecology, APR 20-22, 2017, Targu Mures, ROMANIA, ISBN: 978-88-95922-88-1, Published: 2017;
35. Bernad, S.E., Craina, M., Bernad, I.S., Moza, A. Ultrasound Evaluation of the Placenta and its Influence on the Fetal Wellbeing at the Moment of Birth, 5TH ROMANIAN CONGRESS OF THE ROMANIAN SOCIETY OF ULTRASOUND IN OBSTETRICS AND GYNECOLOGY, Pages: 78-82, 5th Romanian Congress of the Romanian-Society-of-Ultrasound-in-Obstetrics-and-Gynecology, APR 20-22, 2017, Targu Mures, ROMANIA, ISBN: 978-88-95922-88-1, Published: 2017;
36. Bernad, S.E., Bernad, S.I., Moza, A., Craina, M. Risk Factors Association to Pregnancies Induced Hypertension, 5TH ROMANIAN CONGRESS OF THE ROMANIAN SOCIETY OF ULTRASOUND IN OBSTETRICS AND GYNECOLOGY, Pages: 83-87, 5th Romanian Congress of the Romanian-Society-of-Ultrasound-in-Obstetrics-and-Gynecology, APR 20-22, 2017, Targu Mures, ROMANIA, ISBN: 978-88-95922-88-1, Published: 2017;

37. Bernad, S.E., Moza, A., Bernad, I.S., Craina, M. Ultrasound Assessment of the Umbilical Cord Knot, 5TH ROMANIAN CONGRESS OF THE ROMANIAN SOCIETY OF ULTRASOUND IN OBSTETRICS AND GYNECOLOGY, Pages: 88-92, 5th Romanian Congress of the Romanian-Society-of-Ultrasound-in-Obstetrics-and-Gynecology, APR 20-22, 2017, Targu Mures, ROMANIA, ISBN: 978-88-95922-88-1, Published: 2017;
38. Bernad, S.I., Bosioc, A.I., Totorean, A.F., Petre, I., Bernad, E.S. Wall Shear Stress Evolution in Carotid Artery Bifurcation, PROCEEDINGS OF THE INTERNATIONAL CONFERENCE ON NUMERICAL ANALYSIS AND APPLIED MATHEMATICS 2016 (ICNAAM-2016), Book Series: AIP Conference Proceedings, Volume: 1863, Article Number: UNSP 30020-1, International Conference on Numerical Analysis and Applied Mathematics (ICNAAM), SEP 19-25, 2016, Rhodes, GREECE, ISSN: 0094-243X, ISBN: 978-0-7354-1538-6, Published: 2017;
39. Berto, F., Marsavina, L., Razavi, S.M.J., Ayatollahi, M.R. On the fracture behavior of polyurethane notched components, XXIV ITALIAN GROUP OF FRACTURE CONFERENCE, 2017, Book Series: Procedia Structural Integrity, Volume: 3, Pages: 144-152, 24th Italian-Group-of-Fracture (IGF) Conference, MAR 01-03, 2017, Urbino, ITALY, ISSN: 2452-3216, Published: 2017;
40. Biba, D.R., Musuroi, S., Svoboda, M. A New Approach to Lifetime and Loading Stress Level Estimation for Multilayer Ceramic Capacitors in Electronic Control Units, 2017 INTERNATIONAL CONFERENCE ON OPTIMIZATION OF ELECTRICAL AND ELECTRONIC EQUIPMENT (OPTIM) & 2017 INTL AEGEAN CONFERENCE ON ELECTRICAL MACHINES AND POWER ELECTRONICS (ACEMP), Pages: 37-42, International Conference on Optimization of Electrical and Electronic Equipment (OPTIM) / Intl Aegean Conference on Electrical Machines and Power Electronics (ACEMP), MAY 25-27, 2017, Brasov, ROMANIA, ISBN: 978-1-5090-4489-4, Published: 2017;
41. Bindean, I.A., Fofiu, M., Stoian, V. Energy Dissipation of retrofitted Precast Reinforced Concrete Walls subjected to seismic loading, MODERN TECHNOLOGIES FOR THE 3RD MILLENNIUM, Pages: 123-126, 16th National Technical-Scientific Conference on Modern Technologies for the 3rd Millennium, MAR 23-24, 2017, Oradea, ROMANIA, ISBN: 978-88-87729-41-2, Published: 2017;
42. Birdeanu, M., Vaida, M., Ursu, D., Fagadar-Cosma, E. Obtaining and Characterization of Zn3V2O8 and Mg3V2O8 Pseudo Binary Oxide Nanomaterials by Hydrothermal Method, TIM15-16 PHYSICS CONFERENCE, Book Series: AIP Conference Proceedings, Volume: 1796, Article Number: UNSP 030006-1, TIM15-16 Physics Conference, MAY 26-28, 2016, Timisoara, ROMANIA, ISSN: 0094-243X, ISBN: 978-0-7354-1462-4, Published: 2017;
43. Birtok-Baneasa, C., Ratiu, S.A., Alexa, V., Craciun, A.L., Josan, A., Budiul-Berghian, A. Reducing emissions by using special air filters for internal combustion engines, INNOVATIVE IDEAS IN SCIENCE 2016, Book Series: IOP Conference Series-Materials Science and Engineering, Volume: 200, Article Number: UNSP 012011, Conference on Innovative Ideas in Science, NOV 10-11, 2016, Baia Mare, ROMANIA, ISSN: 1757-8981, Published: 2017;
44. Birtok-Baneasa, C., Ratiu, S., Heput, T. Influence of intake air temperature on internal combustion engine operation, INTERNATIONAL CONFERENCE ON APPLIED SCIENCES (ICAS2016), Book Series: IOP Conference Series-Materials Science and Engineering, Volume: 163, Article Number: UNSP 012039, International Conference on Applied Sciences (ICAS), MAY 25-27, 2016, Hunedoara, ROMANIA, ISSN: 1757-8981, Published: 2017;
45. Birtok-Baneasa, C., Ratiu, S.A., Heput, T. Calculation of Thermal Conductivity for New Materials used in Intake Systems of Internal Combustion Engines, PROCEEDINGS OF THE INTERNATIONAL CONFERENCE ON NUMERICAL ANALYSIS AND APPLIED MATHEMATICS 2016 (ICNAAM-2016), Book Series: AIP Conference Proceedings, Volume: 1863, Article Number: UNSP 130008-1, International Conference on Numerical Analysis and Applied Mathematics (ICNAAM), SEP 19-25, 2016, Rhodes, GREECE, ISSN: 0094-243X, ISBN: 978-0-7354-1538-6, Published: 2017;
46. Blaj, C., Toader, D., Maghet, A., Pop, O. Electro-mechanic Transient on Starting DC Electrical Machine Using a Semi-controlled Rectifier, 2017 14TH INTERNATIONAL CONFERENCE ON ENGINEERING OF MODERN ELECTRIC SYSTEMS (EMES), Pages: 99-102, 14th International Conference on Engineering of Modern Electric Systems (EMES), JUN 01-02, 2017, ORADEA, ROMANIA, ISBN: 978-1-5090-6073-3, Published: 2017;
47. Blidariu, C., Giurea, D. TETRAPOLIS - an exercise in building the complexities of proximity space, ERPA INTERNATIONAL CONGRESSES ON EDUCATION 2017 (ERPA 2017), Book Series: SHS Web of Conferences, Volume: 37, Article Number: 01009, ERPA International Congresses on Education (ERPA), MAY 18-21, 2017, Budapest, HUNGARY, ISSN: 2261-2424, Published: 2017;
48. Bodin, F., Mnerie, D., Tucu, D., Nagy, V. ELEMENTS TO OPTIMIZE OF THE EDUCATIONAL AND FORMATIVE MANAGEMENT OF ENGINEERS SPECIALIZED FOR JOBS IN THE AGRICULTURE'S MECHANIZATION, ACTUAL TASKS ON AGRICULTURAL ENGINEERING, Book Series: Actual Tasks on Agricultural Engineering-Zagreb, Volume: 45, Pages: 623-629, 45th International Symposium on Agricultural Engineering, FEB 21-24, 2017, Opatija, CROATIA, ISSN: 1848-4425, Published: 2017;

49. Boita, I.E., Dan, D., Stoian, V.A., Florut, S.C., Todea, V.C. Composite Steel Fibber Reinforced Concrete Shear Walls with Vertical Steel Encased Profiles. Experimental Study, MODERN TECHNOLOGIES FOR THE 3RD MILLENNIUM, Pages: 127-132, 16th National Technical-Scientific Conference on Modern Technologies for the 3rd Millennium, MAR 23-24, 2017, Oradea, ROMANIA, ISBN: 978-88-87729-41-2, Published: 2017;
50. Boita, I.E., Dan, D., Stoian, V. Seismic Behaviour of Composite Steel Fibre Reinforced Concrete Shear Walls, WORLD MULTIDISCIPLINARY CIVIL ENGINEERING-ARCHITECTURE-URBAN PLANNING SYMPOSIUM – WMCAUS, Book Series: IOP Conference Series-Materials Science and Engineering, Volume: 245, Article Number: UNSP 022006, World Multidisciplinary Civil Engineering-Architecture-Urban Planning Symposium (WMCAUS), JUN 12-16, 2017, Prague, CZECH REPUBLIC, ISSN: 1757-8981, Published: 2017;
51. Bojan-Dragos, C.A., Precup, R.E., Hergane, S., Teban, T.A., Petriu, E.M. Fuzzy Logic-Based Adaptive Control Scheme for Magnetic Levitation Systems, 2017 IEEE 5TH INTERNATIONAL SYMPOSIUM ON ROBOTICS AND INTELLIGENT SENSORS (IRIS), Pages: 160-165, 5th IEEE International Symposium on Robotics and Intelligent Sensors (IEEE IRIS), OCT 05-07, 2017, Ottawa, CANADA, ISBN: 978-1-5386-1342-9, Published: 2017;
52. Bojan-Dragos, C.A., Precup, R.E., Preitl, S., Radac, M.B., Matei, D.A., Tanasoiu, O., Petriu, E.M. Combined Control Solution for an Advanced Mechatronics Application, 2017 21ST INTERNATIONAL CONFERENCE ON SYSTEM THEORY, CONTROL AND COMPUTING (ICSTCC), Book Series: International Conference on System Theory Control and Computing, Pages: 629-634, 21st International Conference on System Theory, Control and Computing (ICSTCC), OCT 19-21, 2017, Sinaia, ROMANIA, ISSN: 2372-1618, ISBN: 978-1-5386-3842-2, Published: 2017;
53. Boldea, I., Popa, A., Tutelea, L. Large wind generators design, performance and control: an overview, 2017 INTERNATIONAL SYMPOSIUM ON POWER ELECTRONICS (EE), 19th International Symposium on Power Electronics (Ee), OCT 19-21, 2017, NOVI SAD, SERBIA, ISBN: 978-1-5386-3502-5, Published: 2017;
54. Boldea, I., Tutelea, L.N., Hulea, D., Muntean, N. A step capacitor controlled 1 phase a.c. autonomous PM generator, with experiments, 2017 INTERNATIONAL CONFERENCE ON OPTIMIZATION OF ELECTRICAL AND ELECTRONIC EQUIPMENT (OPTIM) & 2017 INTL AEGEAN CONFERENCE ON ELECTRICAL MACHINES AND POWER ELECTRONICS (ACEMP), Pages: 253-260, International Conference on Optimization of Electrical and Electronic Equipment (OPTIM) / Intl Aegean Conference on Electrical Machines and Power Electronics (ACEMP), MAY 25-27, 2017, Brasov, ROMANIA, ISBN: 978-1-5090-4489-4, Published: 2017;
55. Boncalo, O., Savin, V., Amaricai, A. Unrolled Layered Architectures For Non-Surjective Finite Alphabet Iterative Decoders, 2017 IEEE NORDIC CIRCUITS AND SYSTEMS CONFERENCE (NORCAS): NORCHIP AND INTERNATIONAL SYMPOSIUM OF SYSTEM-ON-CHIP (SOC), IEEE Nordic Circuits and Systems Conference (NORCAS) / NORCHIP and International Symposium of System-on-Chip (SoC), OCT 23-25, 2017, Linkoping, SWEDEN, ISBN: 978-1-5386-2844-7, Published: 2017;
56. Bordeasu, I., Popoviciu, M.O., Salcianu, L.C., Ghera, C., Micu, L.M., Badarau, R., Iosif, A., Pirvulescu, L.D., Podoleanu, C.E. A new concept for stainless steels ranking upon the resistance to cavitation erosion, INTERNATIONAL CONFERENCE ON APPLIED SCIENCES (ICAS2016), Book Series: IOP Conference Series-Materials Science and Engineering, Volume: 163, Article Number: UNSP 012002, International Conference on Applied Sciences (ICAS), MAY 25-27, 2016, Hunedoara, ROMANIA, ISSN: 1757-8981, Published: 2017;
57. Bosioc, A.I., Stuparu, A., Susan-Resiga, R. Numerical Analysis of Temperature and Torque in A Magneto-Rheological Clutch, PROCEEDINGS OF THE INTERNATIONAL CONFERENCE ON NUMERICAL ANALYSIS AND APPLIED MATHEMATICS 2016 (ICNAAM-2016), Book Series: AIP Conference Proceedings, Volume: 1863, Article Number: UNSP 030015-1, International Conference on Numerical Analysis and Applied Mathematics (ICNAAM), SEP 19-25, 2016, Rhodes, GREECE, ISSN: 0094-243X, ISBN: 978-0-7354-1538-6, Published: 2017;
58. Both, I., Marginean, I., Neagu, C., Dinu, F., Dubina, D., Zaharia, R. EXPERIMENTAL RESEARCH ON T-STUBS UNDER ELEVATED TEMPERATURES, APPLICATIONS OF STRUCTURAL FIRE ENGINEERING, Book Series: Applications of Structural Fire Engineering-Series, International Conference on Applications of Structural Fire Engineering, OCT 15-16, 2015, Dubrovnik, CROATIA, ISSN: 2336-7318, ISBN: 978-80-01-06194-7, Published: 2017;
59. Branea, A.M., Gaman, M., Badescu, S. Social, Spatial and Legislative Strategy to Shift Urban Mobility Patterns, WORLD MULTIDISCIPLINARY CIVIL ENGINEERING-ARCHITECTURE-URBAN PLANNING SYMPOSIUM – WMCAUS, Book Series: IOP Conference Series-Materials Science and Engineering, Volume: 245, Article Number: UNSP 082016, World Multidisciplinary Civil Engineering-Architecture-Urban Planning Symposium (WMCAUS), JUN 12-16, 2017, Prague, CZECH REPUBLIC, ISSN: 1757-8981, Published: 2017;

60. Branea, A.M., Gaman, M.S., Badescu, S. Network of Green Areas within Collective Housing Communities - Case Study from Timisoara, Romania, WORLD MULTIDISCIPLINARY CIVIL ENGINEERING-ARCHITECTURE-URBAN PLANNING SYMPOSIUM – WMCAUS, Book Series: IOP Conference Series-Materials Science and Engineering, Volume: 245, Article Number: UNSP 082018, World Multidisciplinary Civil Engineering-Architecture-Urban Planning Symposium (WMCAUS), JUN 12-16, 2017, Prague, CZECH REPUBLIC, ISSN: 1757-8981, Published: 2017;
61. Branea, A.M., Gaman, M., Badescu, S. Urban Mobility Analysis on Efficiency and Sustainability by Means of Transportation, WORLD MULTIDISCIPLINARY CIVIL ENGINEERING-ARCHITECTURE-URBAN PLANNING SYMPOSIUM - WMCAUS, Book Series: IOP Conference Series-Materials Science and Engineering, Volume: 245, Article Number: UNSP 082020, World Multidisciplinary Civil Engineering-Architecture-Urban Planning Symposium (WMCAUS), JUN 12-16, 2017, Prague, CZECH REPUBLIC, ISSN: 1757-8981, Published: 2017;
62. Brata, S., Cotorobai, V., Brata, S., Tanasa, C. Thermal Performances of a Ground-Air Heat Exchanger Integrated in a Mechanical Ventilation System of a Residential Building - Daily and Hourly Models, MODERN TECHNOLOGIES FOR THE 3RD MILLENNIUM, Pages: 133-138, 16th National Technical-Scientific Conference on Modern Technologies for the 3rd Millennium, MAR 23-24, 2017, Oradea, ROMANIA, ISBN: 978-88-87729-41-2, Published: 2017;
63. Bujor, M. Proof of concept mathematical model of a modulation breaking the Shannon limit, 2017 IEEE 23RD INTERNATIONAL SYMPOSIUM FOR DESIGN AND TECHNOLOGY IN ELECTRONIC PACKAGING (SIITME), Pages: 304-308, 23rd IEEE International Symposium for Design and Technology in Electronic Packaging (SIITME), OCT 26-29, 2017, Constanta, ROMANIA, ISBN: 978-1-5386-1626-0, Published: 2017;
64. Bularka, S., Gontean, A. Dynamic PV Array Reconfiguration under Suboptimal Conditions in Hybrid Solar Energy Harvesting Systems, 2017 IEEE 23RD INTERNATIONAL SYMPOSIUM FOR DESIGN AND TECHNOLOGY IN ELECTRONIC PACKAGING (SIITME), Pages: 419-422, 23rd IEEE International Symposium for Design and Technology in Electronic Packaging (SIITME), OCT 26-29, 2017, Constanta, ROMANIA, ISBN: 978-1-5386-1626-0, Published: 2017;
65. Bularka, S., Gontean, A. Hybrid-loop Controlled Solar Tracker for Hybrid Solar Energy Harvester, 2017 25TH TELECOMMUNICATION FORUM (TELFOR), Pages: 581-584, 25th Telecommunication Forum (TELFOR), NOV 21-22, 2017, Belgrade, SERBIA, ISBN: 978-1-5386-3073-0, Published: 2017;
66. Bumb, C., Radac, M.B., Precup, R.E., Roman, R.C. Data-Driven Nonlinear VRFT for Dead-Zone Compensation in Servo Systems Control, 2017 21ST INTERNATIONAL CONFERENCE ON SYSTEM THEORY, CONTROL AND COMPUTING (ICSTCC), Book Series: International Conference on System Theory Control and Computing, Pages: 816-821, 21st International Conference on System Theory, Control and Computing (ICSTCC), OCT 19-21, 2017, Sinaia, ROMANIA, ISSN: 2372-1618, ISBN: 978-1-5386-3842-2, Published: 2017;
67. Burca, M., Lucaciu, I., Magda, A. TECHNOLOGICAL PARTICULARITIES REGARDING MANUAL METAL ARC WELDING USING PULSED CURRENT FOR BUTT JOINTS, METAL 2017: 26TH INTERNATIONAL CONFERENCE ON METALLURGY AND MATERIALS, Pages: 930-935, 26th International Conference on Metallurgy and Materials (METAL), MAY 24-26, 2017, Brno, CZECH REPUBLIC, ISBN: 978-80-87294-79-6, Published: 2017;
68. Busuioc, S., Ambrus, V.E., Sofonea, V. Lattice Boltzmann Simulation of Droplet Formation in T-junction Geometries, TIM15-16 PHYSICS CONFERENCE, Book Series: AIP Conference Proceedings, Volume: 1796, Article Number: UNSP 020009, TIM15-16 Physics Conference, MAY 26-28, 2016, Timisoara, ROMANIA, ISSN: 0094-243X, ISBN: 978-0-7354-1462-4, Published: 2017;
69. Buteica, D., Borbath, I., Nicolae, I.V., Turcu, R., Marinica, O., Socoliuc, V. Optimization of Multicore-Shell Fe<sub>3</sub>O<sub>4</sub>-SiO<sub>2</sub> Magnetic Nanocomposites Synthesis and Retention in Cellulose Pulp, TIM17 PHYSICS CONFERENCE, Book Series: AIP Conference Proceedings, Volume: 1916, Article Number: UNSP 040013, 17th Physics Conference, MAY 25-27, 2017, Timisoara, ROMANIA, ISSN: 0094-243X, ISBN: 978-0-7354-1608-6, Published: 2017;
70. Canda, L.R., Ardelean, E. Preliminary experimental research for silver recovery from radiographic films, INTERNATIONAL CONFERENCE ON APPLIED SCIENCES (ICAS2016), Book Series: IOP Conference Series-Materials Science and Engineering, Volume: 163, Article Number: UNSP 012024, International Conference on Applied Sciences (ICAS), MAY 25-27, 2016, Hunedoara, ROMANIA, ISSN: 1757-8981, Published: 2017;
71. Carjan, R., Idiceanu-Mathe, D., Banescu, O.A. Rural Systematization as an Instrument of Political Control of the Communist Regime in Romania, WORLD MULTIDISCIPLINARY CIVIL ENGINEERING-ARCHITECTURE-URBAN PLANNING SYMPOSIUM – WMCAUS, Book Series: IOP Conference Series-Materials Science and Engineering, Volume: 245, Article Number: UNSP 052053, World Multidisciplinary Civil Engineering-Architecture-Urban Planning Symposium (WMCAUS), JUN 12-16, 2017, Prague, CZECH REPUBLIC, ISSN: 1757-8981, Published: 2017;



72. Cebrucean, D., Cebrucean, V., Ionel, I. Efficiency Improvement of an Iron-based Syngas Fueled Chemical Looping Combustion Plant with Carbon Capture, 13TH INTERNATIONAL CONFERENCE ON GREENHOUSE GAS CONTROL TECHNOLOGIES, GHGT-13, Book Series: Energy Procedia, Volume: 114, Pages: 309-316, 13th International Conference on Greenhouse Gas Control Technologies (GHGT), NOV 14-18, 2016, Lausanne, SWITZERLAND, ISSN: 1876-6102, Published: 2017;
73. Chatterjee, S., Dzitac, S., Sen, S., Rohatinovici, N.C., Dey, N., Ashour, A.S., Balas, V.E. Hybrid Modified Cuckoo Search-Neural Network in Chronic Kidney Disease Classification, 2017 14TH INTERNATIONAL CONFERENCE ON ENGINEERING OF MODERN ELECTRIC SYSTEMS (EMES), Pages: 164-167, 14th International Conference on Engineering of Modern Electric Systems (EMES), JUN 01-02, 2017, ORADEA, ROMANIA, ISBN: 978-1-5090-6073-3, Published: 2017;
74. Chilnicean, G.A., Sprancenatu, R., Zhao, X.K., Craciunescu, C.M. Development of Ti-Nb-Zr Shape Memory Alloys, TIM17 PHYSICS CONFERENCE, Book Series: AIP Conference Proceedings, Volume: 1916, Article Number: UNSP 040008, 17th Physics Conference, MAY 25-27, 2017, Timisoara, ROMANIA, ISSN: 0094-243X, ISBN: 978-0-7354-1608-6, Published: 2017;
75. Chioncel, C.P., Tirian, G.O., Gillich, N., Hatiegan, C., Elisabeta, S. Overview of the wind energy market and renewable energy policy in Romania, INTERNATIONAL CONFERENCE ON APPLIED SCIENCES (ICAS2016), Book Series: IOP Conference Series-Materials Science and Engineering, Volume: 163, Article Number: UNSP 012009, International Conference on Applied Sciences (ICAS), MAY 25-27, 2016, Hunedoara, ROMANIA, ISSN: 1757-8981, Published: 2017;
76. Chirita, M., Kiss, M.L., Banica, R., Ieta, A. Obtaining of 3D Nanostructured alpha-Fe<sub>2</sub>O<sub>3</sub>/Ag Nanosheets Ensembles, TIM15-16 PHYSICS CONFERENCE, Book Series: AIP Conference Proceedings, Volume: 1796, Article Number: UNSP 030005-1, TIM15-16 Physics Conference, MAY 26-28, 2016, Timisoara, ROMANIA, ISSN: 0094-243X, ISBN: 978-0-7354-1462-4, Published: 2017;
77. Cioabla, A.E., Dumitrele, G.A., Popescu, F., Lelea, D., Trif-Tordai, G. Biogas Production Using Residual Waters in Co-fermentation Processes, MATERIALS TODAY-PROCEEDINGS, Volume: 4, Issue: 7, Pages: 6757-6763, Part: 1, 13th International Conference on Nanosciences and Nanotechnologies (NN) / 9th International Symposium on Flexible Organic Electronics (ISFOE), JUL 04-07, 2016, Thessaloniki, GREECE, ISSN: 2214-7853, Published: 2017;
78. Cioata, V.G., Kiss, I., Alexa, V., Ratiu, S.A. The optimization of the position and the magnitude of the clamping forces in machining fixtures, INNOVATIVE IDEAS IN SCIENCE 2016, Book Series: IOP Conference Series-Materials Science and Engineering, Volume: 200, Article Number: UNSP 012015, Conference on Innovative Ideas in Science, NOV 10-11, 2016, Baia Mare, ROMANIA, ISSN: 1757-8981, Published: 2017;
79. Cioata, V.G., Kiss, I., Alexa, V., Ratiu, S.A. Mechanical and thermal analysis of the internal combustion engine piston using Ansys, INTERNATIONAL CONFERENCE ON APPLIED SCIENCES (ICAS2016), Book Series: IOP Conference Series-Materials Science and Engineering, Volume: 163, Article Number: UNSP 012043, International Conference on Applied Sciences (ICAS), MAY 25-27, 2016, Hunedoara, ROMANIA, ISSN: 1757-8981, Published: 2017;
80. Ciupe, V., Margineanu, D., Lovasz, E.C. Scaled Test Stand Simulation for Studying the Behavior of Anti-lock Brake Systems on Bumpy Roads, NEW ADVANCES IN MECHANISMS, MECHANICAL TRANSMISSIONS AND ROBOTICS, Book Series: Mechanisms and Machine Science, Volume: 46, Pages: 197-205, Joint International Conference of the 12th International Conference on Mechanisms and Mechanical Transmissions (MTM) / 23rd International Conference on Robotics (Robotics), OCT 26-27, 2016, Aachen, GERMANY, ISSN: 2211-0984, ISBN: 978-3-319-45450-4; 978-3-319-45449-8, Published: 2017;
81. Coccoeanu, A.L., Cretan, I.A., Cojocinescu, M.I., Man, T.E., Pelea, G.N. Water Wells Monitoring Using SCADA System for Water Supply Network, Case Study: Water Treatment Plant Urseni, Timis County, Romania, WORLD MULTIDISCIPLINARY CIVIL ENGINEERING-ARCHITECTURE-URBAN PLANNING SYMPOSIUM – WMCAUS, Book Series: IOP Conference Series-Materials Science and Engineering, Volume: 245, Article Number: UNSP 022025, World Multidisciplinary Civil Engineering-Architecture-Urban Planning Symposium (WMCAUS), JUN 12-16, 2017, Prague, CZECH REPUBLIC, ISSN: 1757-8981, Published: 2017;
82. Cosnita, R., Caba, C., Nafornta, I. Radio Network Planning using a Design-Build-Operate Model, 2017 INTERNATIONAL SYMPOSIUM ON SIGNALS, CIRCUITS AND SYSTEMS (ISSCS), International Symposium on Signals, Circuits and Systems (ISSCS), JUL 13-14, 2017, Iasi, ROMANIA, ISBN: 978-1-5386-0674-2, Published: 2017;
83. Craciun, A.L., Pinca-Bretotean, C., Birtok-Baneasa, C., Josan, A. Composites materials for friction and braking application, INNOVATIVE IDEAS IN SCIENCE 2016, Book Series: IOP Conference Series-Materials Science and Engineering, Volume: 200, Article Number: UNSP 012009, Conference on Innovative Ideas in Science, NOV 10-11, 2016, Baia Mare, ROMANIA, ISSN: 1757-8981, Published: 2017;

84. Craciun, A.L., Pinca-Bretotean, C., Utu, D., Josan, A. Tribological properties of nonasbestos brake pad material by using coconut fiber, INTERNATIONAL CONFERENCE ON APPLIED SCIENCES (ICAS2016), Book Series: IOP Conference Series-Materials Science and Engineering, Volume: 163, Article Number: UNSP 012014, International Conference on Applied Sciences (ICAS), MAY 25-27, 2016, Hunedoara, ROMANIA, ISSN: 1757-8981, Published: 2017;
85. Cretan, I.A., Nemes, N. Measuring Air Quality in a Construction Site Biotope Using the AQM-65 Analyser, WORLD MULTIDISCIPLINARY CIVIL ENGINEERING-ARCHITECTURE-URBAN PLANNING SYMPOSIUM – WMCAUS, Book Series: IOP Conference Series-Materials Science and Engineering, Volume: 245, Article Number: UNSP 052019, World Multidisciplinary Civil Engineering-Architecture-Urban Planning Symposium (WMCAUS), JUN 12-16, 2017, Prague, CZECH REPUBLIC, ISSN: 1757-8981, Published: 2017;
86. Crisan, A., Ivan, A., Handabut, A. Dynamic Analysis of Internal Wind Pressure on Non-Structural Elements, MODERN TECHNOLOGIES FOR THE 3RD MILLENNIUM, Pages: 147-152, 16th National Technical-Scientific Conference on Modern Technologies for the 3rd Millennium, MAR 23-24, 2017, Oradea, ROMANIA, ISBN: 978-88-87729-41-2, Published: 2017;
87. Crisan, G.C., Tucu, D., Boboescu, R. IMPROVEMENT OF SAFE & HEALTHY WORK SYSTEMS IN AGRICULTURAL SME'S, ACTUAL TASKS ON AGRICULTURAL ENGINEERING, Book Series: Actual Tasks on Agricultural Engineering-Zagreb, Volume: 45, Pages: 657-663, 45th International Symposium on Agricultural Engineering, FEB 21-24, 2017, CROATIA, ISSN: 1848-4425, Published: 2017;
88. Crisan-Vida, M., Jura, D., Stoicu-Tivadar, L., Moza, A., Bernad, E. Communication between Hospital Departments Using Standards, 13TH CONFERENCE OF THE ROMANIAN-GERMAN SOCIETY OF OBSTETRICS AND GYNECOLOGY, Pages: 54-59, 13th Conference of the Romanian-German-Society-of-Obstetrics-and-Gynecology, SEP 14-16, 2017, Timisoara, ROMANIA, ISBN: 978-88-95922-95-9, Published: 2017;
89. Crisan-Vida, M., Vladulescu, A., Stoicu-Tivadar, L., Moza, A., Bernad, E. ICT Solution Supporting Collaboration between Clinicians, 5TH ROMANIAN CONGRESS OF THE ROMANIAN SOCIETY OF ULTRASOUND IN OBSTETRICS AND GYNECOLOGY, Pages: 649-653, 5th Romanian Congress of the Romanian-Society-of-Ultrasound-in-Obstetrics-and-Gynecology, APR 20-22, 2017, Targu Mures, ROMANIA, ISBN: 978-88-95922-88-1, Published: 2017;
90. De Sabata, A., Balint, C., Bechet, P., Miclaus, S. USRP Based HF Spectrum Occupancy Measurements at Two Locations in Central and Western Romania, 2017 INTERNATIONAL SYMPOSIUM ON SIGNALS, CIRCUITS AND SYSTEMS (ISSCS), International Symposium on Signals, Circuits and Systems (ISSCS), JUL 13-14, 2017, Iasi, ROMANIA, ISBN: 978-1-5386-0674-2, Published: 2017;
91. Dinis, C.M., Popa, G.N., Iagar, A. Analysis of synchronous and induction generators used at hydroelectric power plant, INTERNATIONAL CONFERENCE ON APPLIED SCIENCES (ICAS2016), Book Series: IOP Conference Series-Materials Science and Engineering, Volume: 163, Article Number: UNSP 012033, International Conference on Applied Sciences (ICAS), MAY 25-27, 2016, Hunedoara, ROMANIA, ISSN: 1757-8981, Published: 2017;
92. Dinis, C.M., Popa, G.N., Iagar, A. Automation Heating and Pumping for Water Using Zelio PLC, 2017 10TH INTERNATIONAL SYMPOSIUM ON ADVANCED TOPICS IN ELECTRICAL ENGINEERING (ATEE), Book Series: International Symposium on Advanced Topics in Electrical Engineering, Pages: 903-908, 10th International Symposium on Advanced Topics in Electrical Engineering (ATEE), MAR 23-25, 2017, Bucharest, ROMANIA, ISSN: 1843-8571, ISBN: 978-1-5090-5160-1, Published: 2017;
93. Dobrean, C., Greconici, M., Madescu, G., Mot, M., Biriescu, M. FEM Analysis of a Synchronous Generator with Inset Permanent Magnet Rotor, 2017 INTERNATIONAL CONFERENCE ON OPTIMIZATION OF ELECTRICAL AND ELECTRONIC EQUIPMENT (OPTIM) & 2017 INTL AEGEAN CONFERENCE ON ELECTRICAL MACHINES AND POWER ELECTRONICS (ACEMP), Pages: 395-400, International Conference on Optimization of Electrical and Electronic Equipment (OPTIM) / Intl Aegean Conference on Electrical Machines and Power Electronics (ACEMP), MAY 25-27, 2017, Brasov, ROMANIA, ISBN: 978-1-5090-4489-4, Published: 2017;
94. Dolga, V., Dolga, L., Moldovan, C. Modelling and Simulation of Linear Actuators in Mechatronic Systems, NEW ADVANCES IN MECHANISMS, MECHANICAL TRANSMISSIONS AND ROBOTICS, Book Series: Mechanisms and Machine Science, Volume: 46, Pages: 351-358, Joint International Conference of the 12th International Conference on Mechanisms and Mechanical Transmissions (MTM) / 23rd International Conference on Robotics (Robotics), OCT 26-27, 2016, Aachen, GERMANY, ISSN: 2211-0984, ISBN: 978-3-319-45450-4; 978-3-319-45449-8, Published: 2017;

95. Draghici, I., Atanasaie, C., Bosioc, A., Muntean, S., Anton, L.E. Experimental analysis of the global performances for a pump with symmetrical suction elbow at two speeds, SUSTAINABLE SOLUTIONS FOR ENERGY AND ENVIRONMENT, EENVIRO 2016, Book Series: Energy Procedia, Volume: 112, Pages: 225-231, Conference on Sustainable Solutions for Energy and Environment (EENVIRO), OCT 26-28, 2016, Bucharest, ROMANIA, ISSN: 1876-6102, Published: 2017;
96. Draghici, S., Tean, O.P., Raduca, E., Iegan, C.H., Halalae, I., Padureanu, I., Nedeloni, M., Hatiegan, L.B. Study regarding the density evolution of messages and the characteristic functions associated of a LDPC code, INTERNATIONAL CONFERENCE ON APPLIED SCIENCES (ICAS2016), Book Series: IOP Conference Series-Materials Science and Engineering, Volume: 163, Article Number: UNSP 012032, International Conference on Applied Sciences (ICAS), MAY 25-27, 2016, Hunedoara, ROMANIA, ISSN: 1757-8981, Published: 2017;
97. Duma, M.A., Duma, V.F. Two-mirror device for laser scanning systems: Multi-parametric analysis, MODELING ASPECTS IN OPTICAL METROLOGY VI, Book Series: Proceedings of SPIE, Volume: 10330, Article Number: UNSP 1033014, Conference on Modeling Aspects in Optical Metrology VI as part of SPIE Optical Metrology Symposium, JUN 26-28, 2017, Munich, GERMANY, ISSN: 0277-786X, ISBN: 978-1-5106-1106-1; 978-1-5106-1105-4, Published: 2017;
98. Duma, V.F. Analysis of polygonal mirror scanning heads: from industrial to high-end applications in swept sources for OCT, DESIGN AND QUALITY FOR BIOMEDICAL TECHNOLOGIES X, Book Series: Proceedings of SPIE, Volume: 10056, Article Number: UNSP 100560P, Conference on Design and Quality for Biomedical Technologies X, JAN 28-29, 2017, San Francisco, CA, ISSN: 0277-786X, eISSN: 1996-756X, ISBN: 978-1-5106-0553-4; 978-1-5106-0554-1, Published: 2017;
99. Duma, V.F., Cira, O., Demian, D. Optical choppers with rotational elements: Modeling, design, and prototypes, OPTICAL SENSORS 2017, Book Series: Proceedings of SPIE, Volume: 10231, Article Number: UNSP 102311K, Conference on Optical Sensors, APR 24-27, 2017, Prague, CZECH REPUBLIC, ISSN: 0277-786X, ISBN: 978-1-5106-0963-1; 978-1-5106-0964-8, Published: 2017;
100. Duma, V.F., Demian, D., Csukas, E.S., Pop, N., Cira, O. Non-conventional optomechanical choppers: Analysis and design of novel prototypes, OPTIFAB 2017, Book Series: Proceedings of SPIE, Volume: 10448, Article Number: UNSP 104481W, Optifab Conference, OCT 16-20, 2017, Rochester, NY, ISSN: 0277-786X, eISSN: 1996-756X, ISBN: 978-1-5106-1365-2; 978-1-5106-1364-5, Published: 2017;
101. Dutescu, D.A., Radac, M.B., Precup, R.E. Model Predictive Control of a Nonlinear Laboratory Twin Rotor Aero-dynamical System, 2017 IEEE 15TH INTERNATIONAL SYMPOSIUM ON APPLIED MACHINE INTELLIGENCE AND INFORMATICS (SAMI), Pages: 37-42, 15th IEEE International Symposium on Applied Machine Intelligence and Informatics (SAMI), JAN 26-28, 2017, Herlany, SLOVAKIA, ISBN: 978-1-5090-5655-2, Published: 2017;
102. Everson, M., Duma, V.F., Dobre, G. Optical power transmission in a polygon mirror-based swept source optical coherence tomography system, DIGITAL OPTICAL TECHNOLOGIES 2017, Book Series: Proceedings of SPIE, Volume: 10335, Article Number: UNSP 1033520, Conference on Digital Optical Technologies, JUN 26-28, 2017, Munich, GERMANY, ISSN: 0277-786X, eISSN: 1996-756X, ISBN: 978-1-5106-1116-0; 978-1-5106-1115-3, Published: 2017;
103. Everson, M., Duma, V.F., Dobre, G. Geometric & Radiometric Vignetting Associated with a 72-Facet, Off-Axis, Polygon Mirror for Swept Source Optical Coherence Tomography (SS-OCT), TIM15-16 PHYSICS CONFERENCE, Book Series: AIP Conference Proceedings, Volume: 1796, Article Number: 040004, TIM15-16 Physics Conference, MAY 26-28, 2016, Timisoara, ROMANIA, ISSN: 0094-243X, ISBN: 978-0-7354-1462-4, Published: 2017;
104. Farkas, A.Z., Mateas, M., Argesanu, V., Mateas, I. New Methods and Means to Assist the Probation Officers During the Probationer Interview, INTERNATIONAL CONFERENCE MULTIDISCIPLINARY PERSPECTIVES IN THE QUASI-COERCIVE TREATMENT OF OFFENDERS (SPECTO), 6TH EDITION, Pages: 35-40, International Conference on Multidisciplinary Perspectives in the Quasi-Coercive Treatment of Offenders, MAY 11-12, 2017, Freiburg, GERMANY, ISBN: 978-88-95922-99-7, Published: 2017;
105. Fekete-Nagy, L., Mosoarca, M., Partene, E., Diaconu, D. Reinforced Concrete Elements Designed By Alternative Procedure, MODERN TECHNOLOGIES FOR THE 3RD MILLENNIUM, Pages: 159-162, 16th National Technical-Scientific Conference on Modern Technologies for the 3rd Millennium, MAR 23-24, 2017, Oradea, ROMANIA, ISBN: 978-88-87729-41-2, Published: 2017;
106. Filip, B., Frigura-Iliasa, F.M., Dolga, L., Andea, P. Human Machine Interface for the Sluice of a Hydro Power Complex, 2017 IEEE 21ST INTERNATIONAL CONFERENCE ON INTELLIGENT ENGINEERING SYSTEMS (INES), Book Series: IEEE International Conference on Intelligent Engineering Systems, Pages: 147-150, 21st IEEE International Conference on Intelligent Engineering Systems (INES), OCT 20-23, 2017, Larnaca, CYPRUS, ISSN: 1562-5850, ISBN: 978-1-4799-7677-5, Published: 2017;



107. Flori, M., Putan, V., Vilceanu, L. Using the heat flow plate method for determining thermal conductivity of building materials, INTERNATIONAL CONFERENCE ON APPLIED SCIENCES (ICAS2016), Book Series: IOP Conference Series-Materials Science and Engineering, Volume: 163, Article Number: UNSP 012018, International Conference on Applied Sciences (ICAS), MAY 25-27, 2016, Hunedoara, ROMANIA, ISSN: 1757-8981, Published: 2017;
108. Fofiu, M., Stoian, V. Using EBR CFRP Strips only on Failure Cracks to Retrofit a Reinforced Concrete Wall Panel Subjected to Seismic Actions, MODERN TECHNOLOGIES FOR THE 3RD MILLENNIUM, Pages: 163-168, 16th National Technical-Scientific Conference on Modern Technologies for the 3rd Millennium, MAR 23-24, 2017, Oradea, ROMANIA, ISBN: 978-88-87729-41-2, Published: 2017;
109. Frigura-Iliasa, M., Cazacu, E., Frigura-Iliasa, F.M. Educational Perspective of Low Voltage Power Quality In Modern Electric Installations, 2017 16TH INTERNATIONAL CONFERENCE ON INFORMATION TECHNOLOGY BASED HIGHER EDUCATION AND TRAINING (ITHET), Book Series: International Conference on Information Technology Based Higher Education and Training, 16th International Conference on Information Technology Based Higher Education and Training (ITHET), JUL 10-12, 2017, Ohrid, MACEDONIA, ISSN: 2380-1603, ISBN: 978-1-5386-3968-9, Published: 2017;
110. Frigura-Iliasa, M., Cazacu, E., Petrescu, L., Frigura-Iliasa, F.M. Computer Aided Study of the Hard-Magnetic Materials Anisotropy, 2017 IEEE 21ST INTERNATIONAL CONFERENCE ON INTELLIGENT ENGINEERING SYSTEMS (INES), Book Series: IEEE International Conference on Intelligent Engineering Systems, Pages: 109-112, 21st IEEE International Conference on Intelligent Engineering Systems (INES), OCT 20-23, 2017, Larnaca, CYPRUS, ISSN: 1562-5850, ISBN: 978-1-4799-7677-5, Published: 2017;
111. Frioui, M., Shamsyan, M., Gaceu, L., Oprea, O.B., Mnerie, D. RHEOLOGICAL INFLUENCE OF (1-3)(1-6) MUSHROOMS beta-GLUCAN, USED AS FLOUR SUBSTITUTION IN BAKERY INDUSTRY, ACTUAL TASKS ON AGRICULTURAL ENGINEERING, Book Series: Actual Tasks on Agricultural Engineering-Zagreb, Volume: 45, Pages: 377-384, 45th International Symposium on Agricultural Engineering, FEB 21-24, 2017, Opatija, CROATIA, ISSN: 1848-4425, Published: 2017;
112. Frydenberg, M., Andone, D. Collaborative Learning about Augmented Reality from Technology and Business Perspectives, 2017 IEEE 17TH INTERNATIONAL CONFERENCE ON ADVANCED LEARNING TECHNOLOGIES (ICALT), Book Series: IEEE International Conference on Advanced Learning Technologies, Pages: 493-495, 17th IEEE International Conference on Advanced Learning Technologies (ICALT), JUL 03-07, 2017, Timisoara, ROMANIA, ISSN: 2161-3761, ISBN: 978-1-5386-3870-5, Published: 2017;
113. Fulga, S., Davidescu, A., Effenberger, I. Conceptual approach for an in-line quality control system in Additive Manufacturing Powder Bed Fusion processes, 4TH INTERNATIONAL CONFERENCE ON COMPUTING AND SOLUTIONS IN MANUFACTURING ENGINEERING 2016 - COSME'16, Book Series: MATEC Web of Conferences, Volume: 94, Article Number: UNSP 03006, 4th International Conference on Computing and Solutions in Manufacturing Engineering (CoSME), NOV 03-04, 2016, Brasov, ROMANIA, ISSN: 2261-236X, Published: 2017;
114. Fulga, S., Davidescu, A., Effenberger, I. Identification of in-line defects and failures during Additive Manufacturing Powder Bed Fusion processes, 4TH INTERNATIONAL CONFERENCE ON COMPUTING AND SOLUTIONS IN MANUFACTURING ENGINEERING 2016 - COSME'16, Book Series: MATEC Web of Conferences, Volume: 94, Article Number: UNSP 03005, 4th International Conference on Computing and Solutions in Manufacturing Engineering (CoSME), NOV 03-04, 2016, Brasov, ROMANIA, ISSN: 2261-236X, Published: 2017;
115. Gal-Nadasan, N., Gal-Nadasan, E.G., Stoicu-Tivadar, V., Poenaru, D.V., Popa-Andrei, D. Measuring the Negative Impact of Long Sitting Hours at High School Students Using the Microsoft Kinect, HEALTH INFORMATICS MEETS EHEALTH: DIGITAL INSIGHT - INFORMATION-DRIVEN HEALTH & CARE, Book Series: Studies in Health Technology and Informatics, Volume: 236, Pages: 383-388, PubMed ID: 28508821, 11th Annual Conference on Health Informatics Meets eHealth (eHealth), MAY 23-24, 2017, Schloss Schonbrunn, AUSTRIA, ISSN: 0926-9630, eISSN: 1879-8365, ISBN: 978-1-61499-759-7; 978-1-61499-758-0, Published: 2017;
116. Ganea, G. Hindsight: Revealing the Evolution of Dependencies to Developers, 2017 IEEE 24TH INTERNATIONAL CONFERENCE ON SOFTWARE ANALYSIS, EVOLUTION, AND REENGINEERING (SANER), Pages: 511-515, 24th IEEE International Conference on Software Analysis, Evolution and Reengineering (SANER), FEB 20-24, 2017, Klagenfurt, AUSTRIA, ISBN: 978-1-5090-5501-2, Published: 2017;
117. Georgescu, M., Ungureanu, V., Grecea, D., Petran, I. Conversion of a Temporary Tent with Steel Frame into a Permanent Warehouse, WORLD MULTIDISCIPLINARY CIVIL ENGINEERING-ARCHITECTURE-URBAN PLANNING SYMPOSIUM - WMCAUS, Book Series: IOP Conference Series-Materials Science and Engineering, Volume: 245, Article Number: UNSP 022056, World Multidisciplinary Civil Engineering-Architecture-Urban Planning Symposium (WMCAUS), JUN 12-16, 2017, Prague, CZECH REPUBLIC, ISSN: 1757-8981, Published: 2017;

118. Gheju, M., Balcu, I. Cheap metallic iron source for hexavalent chromium removal, 4TH INTERNATIONAL CONFERENCE ON ENERGY AND ENVIRONMENT RESEARCH, ICEER 2017, Book Series: Energy Procedia, Volume: 136, Pages: 133-138, 4th International Conference on Energy and Environment Research (ICEER), JUL 17-20, 2017, Porto, PORTUGAL, ISSN: 1876-6102, Published: 2017;
119. Ghiormez, L., Prostean, O., Panoiu, M., Panoiu, C. GUI for studying the parameters influence of the electric arc model for a three-phase electric arc furnace, INTERNATIONAL CONFERENCE ON APPLIED SCIENCES (ICAS2016), Book Series: IOP Conference Series-Materials Science and Engineering, Volume: 163, Article Number: UNSP 012026, International Conference on Applied Sciences (ICAS), MAY 25-27, 2016, Hunedoara, ROMANIA, ISSN: 1757-8981, Published: 2017;
120. Ghitescu, M.A., Lazar, G., Constantin, A.T., Nicoara, S.V. Numerical Model of Transitory Flood Flow in 2005 on River Timis, WORLD MULTIDISCIPLINARY CIVIL ENGINEERING-ARCHITECTURE-URBAN PLANNING SYMPOSIUM – WMCAUS, Book Series: IOP Conference Series-Materials Science and Engineering, Volume: 245, Article Number: UNSP 022078, World Multidisciplinary Civil Engineering-Architecture-Urban Planning Symposium (WMCAUS), JUN 12-16, 2017, Prague, CZECH REPUBLIC, ISSN: 1757-8981, Published: 2017;
121. Giurea, D., Blidariu, C. Working with mass and light: A challenge for architecture students, ERPA INTERNATIONAL CONGRESSES ON EDUCATION 2017 (ERPA 2017), Book Series: SHS Web of Conferences, Volume: 37, Article Number: 01010, ERPA International Congresses on Education (ERPA), MAY 18-21, 2017, Budapest, HUNGARY, ISSN: 2261-2424, Published: 2017;
122. Greculescu, A., Todorescu, L.L. ENGLISH TEACHER'S CLASSROOM LANGUAGE – AN EMPOWERING TOOL FOR ENGINEERING STUDENTS, 2ND CENTRAL & EASTERN EUROPEAN LUMEN INTERNATIONAL CONFERENCE – MULTIDIMENSIONAL EDUCATION & PROFESSIONAL DEVELOPMENT. ETHICAL VALUES (MEPDEV), 2ND EDITION, Book Series: European Proceedings of Social and Behavioural Sciences, Volume: 27, Pages: 277-282, 2nd Central and Eastern European LUMEN International Conference on Multidimensional Education and Professional Development, Ethical Values (MEPDEV), NOV 17-19, 2016, Targoviste, ROMANIA, ISSN: 2357-1330, Published: 2017;
123. Gridan, M.R., David, V. Digital Terrain Model Draw Up Using Photogrammetry, MODERN TECHNOLOGIES FOR THE 3RD MILLENNIUM, Pages: 23-28, 16th National Technical-Scientific Conference on Modern Technologies for the 3rd Millennium, MAR 23-24, 2017, Oradea, ROMANIA, ISBN: 978-88-87729-41-2, Published: 2017;
124. Gridan, M.R., Herban, S., Grecea, O. Mathematical Support for Surveying Measurements in Order to Obtain the Draft Tube Three-Dimensional Model, PROCEEDINGS OF THE INTERNATIONAL CONFERENCE ON NUMERICAL ANALYSIS AND APPLIED MATHEMATICS 2016 (ICNAAM-2016), Book Series: AIP Conference Proceedings, Volume: 1863, Article Number: UNSP 430003-1, International Conference on Numerical Analysis and Applied Mathematics (ICNAAM), SEP 19-25, 2016, Rhodes, GREECE, ISSN: 0094-243X, ISBN: 978-0-7354-1538-6, Published: 2017;
125. Grigorescu, S.M., Lovasz, E.C., Margineanu, D.T., Pop, C., Pop, F. Dimensional Synthesis of Planar Parallel Manipulator Using Geared Linkages with Linear Actuation as Kinematic Chains, NEW ADVANCES IN MECHANISMS, MECHANICAL TRANSMISSIONS AND ROBOTICS, Book Series: Mechanisms and Machine Science, Volume: 46, Pages: 77-85, Joint International Conference of the 12th International Conference on Mechanisms and Mechanical Transmissions (MTM) / 23rd International Conference on Robotics (Robotics), OCT 26-27, 2016, Aachen, GERMANY, ISSN: 2211-0984, ISBN: 978-3-319-45450-4; 978-3-319-45449-8, Published: 2017;
126. Grozav, A., Beilicci, R., Beilicci, E. Modelling of Sediment Transport of the Mehadica River, Caras Severin County, Romania, WORLD MULTIDISCIPLINARY CIVIL ENGINEERING-ARCHITECTURE-URBAN PLANNING SYMPOSIUM – WMCAUS, Book Series: IOP Conference Series-Materials Science and Engineering, Volume: 245, Article Number: UNSP 032030, World Multidisciplinary Civil Engineering-Architecture-Urban Planning Symposium (WMCAUS), JUN 12-16, 2017, Prague, CZECH REPUBLIC, ISSN: 1757-8981, Published: 2017;
127. Gruicin, I., Popa, M. Airify – A mobile solution for monitoring air quality in urban areas, 2017 25TH TELECOMMUNICATION FORUM (TELFOR), Pages: 705-708, 25th Telecommunication Forum (TELFOR), NOV 21-22, 2017, Belgrade, SERBIA, ISBN: 978-1-5386-3073-0, Published: 2017;
128. Halbac-Cotoara-Zamfir, R., Herban, S., Petursdottir, T., Finger, D.C. APPLIED HYDROTECHNICS IN AGRICULTURE – AN ANSWER TO WATER SCARCITY, ACTUAL TASKS ON AGRICULTURAL ENGINEERING, Book Series: Actual Tasks on Agricultural Engineering-Zagreb, Volume: 45, Pages: 81-86, 45th International Symposium on Agricultural Engineering, FEB 21-24, 2017, Opatija, CROATIA, ISSN: 1848-4425, Published: 2017;

129. Halbac-Cotoara-Zamfir, R., Herban, S., Petursdottir, T., Finger, D.C. INNOVATIVE SUSTAINABLE LAND MANAGEMENT PRACTICES FOR LANDSCAPES UNDER CLIMATE CHANGES THREATS, ACTUAL TASKS ON AGRICULTURAL ENGINEERING, Book Series: Actual Tasks on Agricultural Engineering-Zagreb, Volume: 45, Pages: 17-23, 45th International Symposium on Agricultural Engineering, FEB 21-24, 2017, Opatija, CROATIA, ISSN: 1848-4425, Published: 2017;
130. Halbac-Cotoara-Zamfir, R., Herban, S., Stolte, J., Bozan, C. Integrated Water Hazards Engineering Based on Mapping, Nature-Based and Technical Solutions, WORLD MULTIDISCIPLINARY CIVIL ENGINEERING-ARCHITECTURE-URBAN PLANNING SYMPOSIUM – WMCAUS, Book Series: IOP Conference Series-Materials Science and Engineering, Volume: 245, Article Number: UNSP 022030, World Multidisciplinary Civil Engineering-Architecture-Urban Planning Symposium (WMCAUS), JUN 12-16, 2017, Prague, CZECH REPUBLIC, ISSN: 1757-8981, Published: 2017;
131. Hatiegan, C., Chioncel, C.P., Raduca, E., Popescu, C., Padureanu, I., Jurcu, M.R., Bordeasu, D., Trocaru, S., Dilerteza, F., Badescu, O., Terfaloaga, I.M., Bara, A., Hatiegan, L.B. Determining the operating performance through electrical measurements of a hydro generator, INTERNATIONAL CONFERENCE ON APPLIED SCIENCES (ICAS2016), Book Series: IOP Conference Series-Materials Science and Engineering, Volume: 163, Article Number: UNSP 012031, International Conference on Applied Sciences (ICAS), MAY 25-27, 2016, Hunedoara, ROMANIA, ISSN: 1757-8981, Published: 2017;
132. Hedrea, L.E., Bojan-Dragos, C.A., Precup, R.E., Roman, R.C., Petriu, E.M., Hedrea, C. Tensor Product-Based Model Transformation for Position Control of Magnetic Levitation Systems, 2017 IEEE 26TH INTERNATIONAL SYMPOSIUM ON INDUSTRIAL ELECTRONICS (ISIE), Book Series: Proceedings of the IEEE International Symposium on Industrial Electronics, Pages: 1141-1146, 26th IEEE International Symposium on Industrial Electronics (ISIE), JUN 18-21, 2017, Edinburgh, SCOTLAND, ISSN: 2163-5137, ISBN: 978-1-5090-1412-5, Published: 2017;
133. Hedrea, E.L., Bojan-Dragos, C.A., Precup, R.E., Teban, T.A. Tensor Product-Based Model Transformation for Level Control of Vertical Three Tank Systems, 2017 IEEE 21ST INTERNATIONAL CONFERENCE ON INTELLIGENT ENGINEERING SYSTEMS (INES), Book Series: IEEE International Conference on Intelligent Engineering Systems, Pages: 113-118, 21st IEEE International Conference on Intelligent Engineering Systems (INES), OCT 20-23, 2017, Larnaca, CYPRUS, ISSN: 1562-5850, ISBN: 978-1-4799-7677-5, Published: 2017;
134. Herisanu, N. Optimal Homotopy Asymptotic Approaches to Nonlinear Dynamical Systems in Engineering, PROCEEDINGS OF THE INTERNATIONAL CONFERENCE ON NUMERICAL ANALYSIS AND APPLIED MATHEMATICS 2016 (ICNAAM-2016), Book Series: AIP Conference Proceedings, Volume: 1863, Article Number: UNSP 460001-1, International Conference on Numerical Analysis and Applied Mathematics (ICNAAM), SEP 19-25, 2016, Rhodes, GREECE, ISSN: 0094-243X, ISBN: 978-0-7354-1538-6, Published: 2017;
135. Herisanu, N., Marinca, V., Madescu, G. Nonlinear Dynamics of a Wind Turbine Permanent Magnet Generator System in Different Wind Profile Conditions, PROCEEDINGS OF THE INTERNATIONAL CONFERENCE ON NUMERICAL ANALYSIS AND APPLIED MATHEMATICS 2016 (ICNAAM-2016), Book Series: AIP Conference Proceedings, Volume: 1863, Article Number: UNSP 460002-1, International Conference on Numerical Analysis and Applied Mathematics (ICNAAM), SEP 19-25, 2016, Rhodes, GREECE, ISSN: 0094-243X, ISBN: 978-0-7354-1538-6, Published: 2017;
136. Hutiu, G., Duma, V.F., Demian, D., Bradu, A., Podoleanu, A.G. Analysis of the fractures of metallic materials using optical coherence tomography, OPTICAL MEASUREMENT SYSTEMS FOR INDUSTRIAL INSPECTION X, Book Series: Proceedings of SPIE, Volume: 10329, Article Number: UNSP 103292D, Conference on Optical Measurement Systems for Industrial Inspection X part of the SPIE Optical Metrology Symposium, JUN 26-29, 2017, Munich, GERMANY, ISSN: 0277-786X, eISSN: 1996-756X, ISBN: 978-1-5106-1104-7; 978-1-5106-1103-0, Published: 2017;
137. Iacobici, N.L., Andea, P., Frigura-Iliasa, F.M., Frigura-Iliasa, M. A New Computer Based Design for a 145 kV SF6 Switch, 2017 IEEE 15TH INTERNATIONAL SYMPOSIUM ON APPLIED MACHINE INTELLIGENCE AND INFORMATICS (SAMI), Pages: 207-212, 15th IEEE International Symposium on Applied Machine Intelligence and Informatics (SAMI), JAN 26-28, 2017, Herlany, SLOVAKIA, ISBN: 978-1-5090-5655-2, Published: 2017;
138. Iacobici, N.L., Frigura-Iliasa, F.M., Vatau, D., Andea, P. Command and Control Interface for a Navigation Lock at a Hydro Power Dam, 2017 INTERNATIONAL CONFERENCE ON INFORMATION AND DIGITAL TECHNOLOGIES (IDT), Pages: 142-145, International Conference on Information and Digital Technologies (IDT), JUL 05-07, 2017, Zilina, SLOVAKIA, ISBN: 978-1-5090-5689-7, Published: 2017;
139. Iagar, A., Dinis, C.M., Popa, G.N. Experimental analysis of direct current corona discharge, INTERNATIONAL CONFERENCE ON APPLIED SCIENCES (ICAS2016), Book Series: IOP Conference Series-Materials Science and Engineering, Volume: 163, Article Number: UNSP 012035, International Conference on Applied Sciences (ICAS), MAY 25-27, 2016, Hunedoara, ROMANIA, ISSN: 1757-8981, Published: 2017;

140. Iagar, A., Popa, G.N., Dinis, C.M. Study of electromagnetic radiation produced by household equipment, INNOVATIVE IDEAS IN SCIENCE 2016, Book Series: IOP Conference Series–Materials Science and Engineering, Volume: 200, Article Number: UNSP 012014, Conference on Innovative Ideas in Science, NOV 10–11, 2016, Baia Mare, ROMANIA, ISSN: 1757–8981, Published: 2017;
141. Iagar, A., Popa, G.N., Dinis, C.M. Investigation of Power Quality Problems at a Wood-Based Panels Plant, 2017 10TH INTERNATIONAL SYMPOSIUM ON ADVANCED TOPICS IN ELECTRICAL ENGINEERING (ATEE), Book Series: International Symposium on Advanced Topics in Electrical Engineering, Pages: 579–584, 10th International Symposium on Advanced Topics in Electrical Engineering (ATEE), MAR 23–25, 2017, Bucharest, ROMANIA, ISSN: 1843–8571, ISBN: 978–1–5090–5160–1, Published: 2017;
142. Idiceanu–Mathe, D., Carjan, R. Marasti Village, 1918–1924 ... A Neo–Romanian Experiment, WORLD MULTIDISCIPLINARY CIVIL ENGINEERING–ARCHITECTURE–URBAN PLANNING SYMPOSIUM – WMCAUS, Book Series: IOP Conference Series–Materials Science and Engineering, Volume: 245, Article Number: UNSP 052039, World Multidisciplinary Civil Engineering–Architecture–Urban Planning Symposium (WMCAUS), JUN 12–16, 2017, Prague, CZECH REPUBLIC, ISSN: 1757–8981, Published: 2017;
143. Ionascu, M.E., Marcu, M. Energy Profiling for Different Bluetooth Low Energy Designs, PROCEEDINGS OF THE 2017 9TH IEEE INTERNATIONAL CONFERENCE ON INTELLIGENT DATA ACQUISITION AND ADVANCED COMPUTING SYSTEMS: TECHNOLOGY AND APPLICATIONS (IDAACS), VOL 2, Pages: 1032–1036, 9th IEEE International Conference on Intelligent Data Acquisition and Advanced Computing Systems – Technology and Applications (IDAACS), SEP 21–23, 2017, Bucharest, ROMANIA, ISBN: 978–1–5386–0697–1, Published: 2017;
144. Ionel, I., Makra, L., Bisorca, D., Calinoiu, D.G., Balogh, R.M. From Theory to Practice Concerning Air Quality Monitoring, TIM15–16 PHYSICS CONFERENCE, Book Series: AIP Conference Proceedings, Volume: 1796, Article Number: UNSP 040002–1, TIM15–16 Physics Conference, MAY 26–28, 2016, Timisoara, ROMANIA, ISSN: 0094–243X, ISBN: 978–0–7354–1462–4, Published: 2017;
145. Isfanuti, A.S., Tutelea, L.N., Boldea, I., Staudt, T. Small–power 4 stator–pole stator–ferrite PMSM single–phase self–starting motor drive: FEM–based optimal design and controlled dynamics, 2017 INTERNATIONAL CONFERENCE ON OPTIMIZATION OF ELECTRICAL AND ELECTRONIC EQUIPMENT (OPTIM) & 2017 INTL AEGEAN CONFERENCE ON ELECTRICAL MACHINES AND POWER ELECTRONICS (ACEMP), Pages: 517–522, International Conference on Optimization of Electrical and Electronic Equipment (OPTIM) / Intl Aegean Conference on Electrical Machines and Power Electronics (ACEMP), MAY 25–27, 2017, Brasov, ROMANIA, ISBN: 978–1–5090–4489–4, Published: 2017;
146. Isvoran, A., Roman, M., Roman, D.L., Ciorsac, A., Ostafe, V. Exploring structural characteristics of chitin deacetylases and chitin oligosaccharide deacetylases, EUROPEAN BIOPHYSICS JOURNAL WITH BIOPHYSICS LETTERS, Meeting Abstract: P–185, Volume: 46, Pages: S163–S163, Supplement: 1, 19th IUPAB Congress / 11th EBSA Congress, JUL 16–20, 2017, Edinburgh, SCOTLAND, ISSN: 0175–7571, eISSN: 1432–1017, Published: 2017;
147. Iures, L., Popa, R., Bob, C., Chendes, R. Practical Use of Steel Fibre Reinforced Concretes for Roads, MODERN TECHNOLOGIES FOR THE 3RD MILLENNIUM, Pages: 169–172, 16th National Technical–Scientific Conference on Modern Technologies for the 3rd Millennium, MAR 23–24, 2017, Oradea, ROMANIA, ISBN: 978–88–87729–41–2, Published: 2017;
148. Ivascu, L., Tamasila, M., Taucean, I., Cioca, L.I., Izvercian, M. EDUCATION FOR SUSTAINABILITY: CURRENT STATUS, PROSPECTS, AND DIRECTIONS, ICCSBS 2017 – THE ANNUAL INTERNATIONAL CONFERENCE ON COGNITIVE – SOCIAL, AND BEHAVIOURAL SCIENCES, Book Series: European Proceedings of Social and Behavioural Sciences, Volume: 20, Pages: 259–267, 5th Annual International Conference on Cognitive – Social, and Behavioural Sciences, JAN 09–11, 2017, Brno, CZECH REPUBLIC, ISSN: 2357–1330, Published: 2017;
149. Ivascu, L., Cioca, L.I., Tamasila, M., Taucean, I., Bigan, C. Risk Management and an Approach for Introducing Functional Safety in the Development of Automotive E/E Systems, SUSTAINABLE ECONOMIC GROWTH, EDUCATION EXCELLENCE, AND INNOVATION MANAGEMENT THROUGH VISION 2020, VOLS I–VII, Pages: 2595–2601, 29th International–Business–Information–Management–Association Conference, MAY 03–04, 2017, Vienna, AUSTRIA, ISBN: 978–0–9860419–7–6, Published: 2017;
150. Jivet, I. An EIT Belt Reference Design with Active Electrodes and Digital Output, INTERNATIONAL CONFERENCE ON ADVANCEMENTS OF MEDICINE AND HEALTH CARE THROUGH TECHNOLOGY, MEDITECH 2016, Book Series: IFMBE Proceedings, Volume: 59, Pages: 73–76, 5th International Conference on Advancements of Medicine and Health Care through Technology (MEDITECH), OCT 12–15, 2016, Cluj Napoca, ROMANIA, ISSN: 1680–0737, ISBN: 978–3–319–52875–5; 978–3–319–52874–8, Published: 2017;

151. Josan, A., Bretotean, C.P., Ratiu, S., Ardelean, E., Ardelean, M. Research on the influence of moulding-casting technology on the quality of castings, INNOVATIVE IDEAS IN SCIENCE 2016, Book Series: IOP Conference Series-Materials Science and Engineering, Volume: 200, Article Number: UNSP 012010, Conference on Innovative Ideas in Science, NOV 10-11, 2016, Baia Mare, ROMANIA, ISSN: 1757-8981, Published: 2017;
152. Josan, A., Bretotean, C.P. Using the anti-adherence paints to manufacturing of the moulds intended for iron castings, INTERNATIONAL CONFERENCE ON APPLIED SCIENCES (ICAS2016), Book Series: IOP Conference Series-Materials Science and Engineering, Volume: 163, Article Number: UNSP 012020, International Conference on Applied Sciences (ICAS), MAY 25-27, 2016, Hunedoara, ROMANIA, ISSN: 1757-8981, Published: 2017;
153. Kazamer, N., Pascal, D.T., Marginean, G., Serban, V.A., Brandl, W. Valean, P.C. ASPECTS CONCERNING THE WEAR AND CORROSION BEHAVIOR OF WC-CO-CR COATINGS AND RESPECTIVELY DLC/WC-CO-CR SYSTEMS, 8TH INTERNATIONAL CONFERENCE ON NANOMATERIALS - RESEARCH & APPLICATION (NANOCON 2016), Pages: 383-388, 8th International Conference on Nanomaterials - Research and Application (NANOCON), OCT 19-21, 2016, Brno, CZECH REPUBLIC, ISBN: 978-80-87294-71-0, Published: 2017;
154. Keller, A., Mosoarca, M. Modern Historic Timber Structure Consolidation Technologies - A State of the Art Review, MODERN TECHNOLOGIES FOR THE 3RD MILLENNIUM, Pages: 179-184, 16th National Technical-Scientific Conference on Modern Technologies for the 3rd Millennium, MAR 23-24, 2017, Oradea, ROMANIA, ISBN: 978-88-87729-41-2, Published: 2017;
155. Kiss, I., Cioata, V.G., Alexa, V., Ratiu, S.A. Multivariate research in areas of phosphorus cast-iron brake shoes manufacturing using the statistical analysis and the multiple regression equations, INNOVATIVE IDEAS IN SCIENCE 2016, Book Series: IOP Conference Series-Materials Science and Engineering, Volume: 200, Article Number: UNSP 012022, Conference on Innovative Ideas in Science, NOV 10-11, 2016, Baia Mare, ROMANIA, ISSN: 1757-8981, Published: 2017;
156. Kiss, I., Alexa, V., Cioata, V.G. Statistical analysis using the multiple regression research in areas of the indefinite chilled cast-iron rolls manufacturing, INNOVATIVE IDEAS IN SCIENCE 2016, Book Series: IOP Conference Series-Materials Science and Engineering, Volume: 200, Article Number: UNSP 012021, Conference on Innovative Ideas in Science, NOV 10-11, 2016, Baia Mare, ROMANIA, ISSN: 1757-8981, Published: 2017;
157. Korodi, A., Silea, I. Achieving Interoperability Using Low-Cost Middleware OPC UA Wrapping Structure. Case Study in the Water Industry, 2017 IEEE 15TH INTERNATIONAL CONFERENCE ON INDUSTRIAL INFORMATICS (INDIN), Book Series: IEEE International Conference on Industrial Informatics INDIN, Pages: 1223-1228, 15th IEEE International Conference on Industrial Informatics (INDIN), JUL 24-26, 2017, Emden, GERMANY, ISSN: 1935-4576, ISBN: 978-1-5386-0837-1, Published: 2017;
158. Kuczapski, A.M., Andreescu, G.D. New Autocorrelation based Self-Learning Method to Detect Sound Spectral Components in Cochlear Nerve Firing Patterns in Case of Cochlear Implants, 2017 40TH INTERNATIONAL CONFERENCE ON TELECOMMUNICATIONS AND SIGNAL PROCESSING (TSP), Pages: 429-434, 40th International Conference on Telecommunications and Signal Processing (TSP), JUL 05-07, 2017, Barcelona, SPAIN, ISBN: 978-1-5090-3982-1, Published: 2017;
159. Lacrama, D.L., Alexa, F., Pinteau, F.A., Zinca, P.G. Expert System for Infrared Heating Panel Optimization, 2017 25TH TELECOMMUNICATION FORUM (TELFOR), Pages: 777-780, 25th Telecommunication Forum (TELFOR), NOV 21-22, 2017, Belgrade, SERBIA, ISBN: 978-1-5386-3073-0, Published: 2017;
160. Lălu, O., Anghel, I., Serban, M., Mocioi, I.A., Branisteanu, B. Experimental researches on determining the fire action response of improved exterior cladding systems provided with incombustible barriers, SUSTAINABLE SOLUTIONS FOR ENERGY AND ENVIRONMENT, EENVIRO 2016, Book Series: Energy Procedia, Volume: 112, Pages: 287-295, Conference on Sustainable Solutions for Energy and Environment (EENVIRO), OCT 26-28, 2016, Bucharest, ROMANIA, ISSN: 1876-6102, Published: 2017;
161. Lazarescu, E., Alexa, F., Vatau, D., Frigura-Iliasa, F.M. The Assessment of the Antenna Circuit of a RF Wheel Unit, 2017 24TH IEEE INTERNATIONAL CONFERENCE ON ELECTRONICS, CIRCUITS AND SYSTEMS (ICECS), Book Series: IEEE International Conference on Electronics Circuits and Systems, Pages: 116-119, 24th IEEE International Conference on Electronics, Circuits and Systems (ICECS), DEC 05-08, 2017, Batumi, GEORGIA, ISBN: 978-1-5386-1911-7, Published: 2017;



162. Lazarescu, E., Frigura-Iliasa, F.M., Frigura-Iliasa, M., Andea, P., Vatau, D. A new Approach to Predictive Maintenance of High Voltage Switching Devices, PROCEEDINGS OF THE 2017 18TH INTERNATIONAL SCIENTIFIC CONFERENCE ON ELECTRIC POWER ENGINEERING (EPE), Book Series: International Scientific Conference on Electric Power Engineering, Pages: 337-340, 18th International Scientific Conference on Electric Power Engineering (EPE), MAY 17-19, 2017, Kouty nad Desnou, CZECH REPUBLIC, ISSN: 2376-5623, ISBN: 978-1-5090-6406-9, Published: 2017;
163. Lica, S., Gurbina, M., Lascu, D., Pop-Calimanu, I.M., Ciresan, A. A Novel Stacked Step-Down Switching Converter, 2017 INTERNATIONAL CONFERENCE ON OPTIMIZATION OF ELECTRICAL AND ELECTRONIC EQUIPMENT (OPTIM) & 2017 INTL AEGEAN CONFERENCE ON ELECTRICAL MACHINES AND POWER ELECTRONICS (ACEMP), Pages: 549-554, International Conference on Optimization of Electrical and Electronic Equipment (OPTIM) / Intl Aegean Conference on Electrical Machines and Power Electronics (ACEMP), MAY 25-27, 2017, Brasov, ROMANIA, ISBN: 978-1-5090-4489-4, Published: 2017;
164. Lica, S., Pop-Calimanu, I.M., Lascu, D., Ciresan, A., Gurbina, M. A New Stacked Step-Up Converter, 2017 40TH INTERNATIONAL CONFERENCE ON TELECOMMUNICATIONS AND SIGNAL PROCESSING (TSP), Pages: 315-319, 40th International Conference on Telecommunications and Signal Processing (TSP), JUL 05-07, 2017, Barcelona, SPAIN, ISBN: 978-1-5090-3982-1, Published: 2017;
165. Linul, E., Marsavina, L. Experimental Determination of Mixed-Mode Fracture Toughness for Rigid Polyurethane Foams, FRACTURE AT ALL SCALES, Book Series: Lecture Notes in Mechanical Engineering, Pages: 221-237, International Conference on Fatigue and Fracture at All Scales (NTZF), SEP 15-18, 2014, Belgrade, SERBIA, ISSN: 2195-4356, ISBN: 978-3-319-32634-4; 978-3-319-32633-7, Published: 2017;
166. Lovasz, E.C., Mesaros-Anghel, V., Gruescu, C.M., Moldovan, C.E., Ceccarelli, M. General Algorithm for Computing the Theoretical Centering Precision of the Gripping Devices, ADVANCES IN MECHANISM DESIGN II, Book Series: Mechanisms and Machine Science, Volume: 44, Pages: 15-21, 12th International Conference on the Theory of Machines and Mechanisms, SEP 06-08, 2016, Liberec, CZECH REPUBLIC, ISSN: 2211-0984, ISBN: 978-3-319-44087-3; 978-3-319-44086-6, Published: 2017;
167. Madescu, G., Biriescu, M., Tutelea, L.N., Mot, M., Boldea, I. Fast Computation of Bar Over-currents in the Faulty Cage of Induction Motors with Experimental Validation, 2017 INTERNATIONAL CONFERENCE ON OPTIMIZATION OF ELECTRICAL AND ELECTRONIC EQUIPMENT (OPTIM) & 2017 INTL AEGEAN CONFERENCE ON ELECTRICAL MACHINES AND POWER ELECTRONICS (ACEMP), Pages: 388-394, International Conference on Optimization of Electrical and Electronic Equipment (OPTIM) / Intl Aegean Conference on Electrical Machines and Power Electronics (ACEMP), MAY 25-27, 2017, Brasov, ROMANIA, ISBN: 978-1-5090-4489-4, Published: 2017;
168. Maduta, C., Brata, S., Pescari, S., Tanasa, C., Stoian, V. Renovation Solutions for Collective Residential Buildings - Case Study, MODERN TECHNOLOGIES FOR THE 3RD MILLENNIUM, Pages: 185-190, 16th National Technical-Scientific Conference on Modern Technologies for the 3rd Millennium, MAR 23-24, 2017, Oradea, ROMANIA, ISBN: 978-88-87729-41-2, Published: 2017;
169. Magaon, M., Ardelean, E., Serban, S., Putan, V. Mathematical Modeling of the Removal Efficiency of Hydrogen from Steels Treated in Vacuum Facilities, PROCEEDINGS OF THE INTERNATIONAL CONFERENCE ON NUMERICAL ANALYSIS AND APPLIED MATHEMATICS 2016 (ICNAAM-2016), Book Series: AIP Conference Proceedings, Volume: 1863, Article Number: UNSP 130006-1, International Conference on Numerical Analysis and Applied Mathematics (ICNAAM), SEP 19-25, 2016, Rhodes, GREECE, ISSN: 0094-243X, ISBN: 978-0-7354-1538-6, Published: 2017;
170. Magaon, M., Serban, S., Heput, T. Research on the reduction of the hydrogen content in steels treated in vacuum, INTERNATIONAL CONFERENCE ON APPLIED SCIENCES (ICAS2016), Book Series: IOP Conference Series-Materials Science and Engineering, Volume: 163, Article Number: UNSP 012015, International Conference on Applied Sciences (ICAS), MAY 25-27, 2016, Hunedoara, ROMANIA, ISSN: 1757-8981, Published: 2017;
171. Magaon, M., Vatasescu, M., Heput, T., Crisan, E. The Optimization of the Removal Process of Nitrogen Content from Steels Treated in Vacuum Facilities, PROCEEDINGS OF THE INTERNATIONAL CONFERENCE ON NUMERICAL ANALYSIS AND APPLIED MATHEMATICS 2016 (ICNAAM-2016), Book Series: AIP Conference Proceedings, Volume: 1863, Article Number: UNSP 130007, International Conference on Numerical Analysis and Applied Mathematics (ICNAAM), SEP 19-25, 2016, Rhodes, GREECE, ISSN: 0094-243X, ISBN: 978-0-7354-1538-6, Published: 2017;
172. Marcu, M., Darie, M., Cernazanu-Glavan, C. Component Level Energy Accounting and Fault Detection on Electrical Devices Using Power Signatures, 2017 IEEE INTERNATIONAL INSTRUMENTATION AND MEASUREMENT TECHNOLOGY CONFERENCE (I2MTC), Pages: 1264-1269, IEEE International Instrumentation and Measurement Technology Conference (I2MTC), MAY 22-27, 2017, Torino, ITALY, ISBN: 978-1-5090-3596-0, Published: 2017;

173. Marginean, I., Both, I., Dogariu, A., Zaharia, R. Advanced Calculation Models in Thermo-Mechanical Analysis, MODERN TECHNOLOGIES FOR THE 3RD MILLENNIUM, Pages: 191-196, 16th National Technical-Scientific Conference on Modern Technologies for the 3rd Millennium, MAR 23-24, 2017, Oradea, ROMANIA, ISBN: 978-88-87729-41-2, Published: 2017;
174. Margineanu, D., Sticlaru, C., Davidescu, A., Margineanu, E. Analytic and FEM Study of Load Distribution on the Length of Spline Joints Under Pure Torque, NEW ADVANCES IN MECHANISMS, MECHANICAL TRANSMISSIONS AND ROBOTICS, Book Series: Mechanisms and Machine Science, Volume: 46, Pages: 69-76, Joint International Conference of the 12th International Conference on Mechanisms and Mechanical Transmissions (MTM) / 23rd International Conference on Robotics (Robotics), OCT 26-27, 2016, Aachen, GERMANY, ISSN: 2211-0984, ISBN: 978-3-319-45450-4; 978-3-319-45449-8, Published: 2017;
175. Marinca, V., Herisanu, N. Approximate Analytic Solutions for Steady MHD Flow and Heat Transfer of a Third Grade Fluid in Wire Coating Process with Constant Viscosity, PROCEEDINGS OF THE INTERNATIONAL CONFERENCE ON NUMERICAL ANALYSIS AND APPLIED MATHEMATICS 2016 (ICNAAM-2016), Book Series: AIP Conference Proceedings, Volume: 1863, Article Number: UNSP 460003-1, International Conference on Numerical Analysis and Applied Mathematics (ICNAAM), SEP 19-25, 2016, Rhodes, GREECE, ISSN: 0094-243X, ISBN: 978-0-7354-1538-6, Published: 2017;
176. Maris, S., Nenu, P.F., Maris, S.A., Slavici, T. ESTIMATING THE CALORIFIC VALUE OF PELLETS FROM DIFFERENT BLENDS OF BIOMASS, ACTUAL TASKS ON AGRICULTURAL ENGINEERING, Book Series: Actual Tasks on Agricultural Engineering-Zagreb, Volume: 45, Pages: 459-464, 45th International Symposium on Agricultural Engineering, FEB 21-24, 2017, Opatija, CROATIA, ISSN: 1848-4425, Published: 2017;
177. Maris, S.A., Tucu, D., Banabatsas, T., Nagy, V., Maris, S., Nenu, P.F. POSSIBILITIES OF USING THE ROBOTS IN GREENHOUSES, ACTUAL TASKS ON AGRICULTURAL ENGINEERING, Book Series: Actual Tasks on Agricultural Engineering-Zagreb, Volume: 45, Pages: 531-537, 45th International Symposium on Agricultural Engineering, FEB 21-24, 2017, Opatija, CROATIA, ISSN: 1848-4425, Published: 2017;
178. Mateas, M., Mateas, I. New Measurement Procedures to Improve the Supervision Risk Assessment, INTERNATIONAL CONFERENCE MULTIDISCIPLINARY PERSPECTIVES IN THE QUASI-COERCIVE TREATMENT OF OFFENDERS (SPECTO), 6TH EDITION, Pages: 47-52, International Conference on Multidisciplinary Perspectives in the Quasi-Coercive Treatment of Offenders, MAY 11-12, 2017, Freiburg, GERMANY, ISBN: 978-88-95922-99-7, Published: 2017;
179. Mesaros-Anghel, V., Lovasz, E.C., Gruescu, C.M., Moldovan, C.E. Optimal Design of a Grasping Device Through Simplified Pose Synthesis of a Four-Bar Linkage, NEW ADVANCES IN MECHANISMS, MECHANICAL TRANSMISSIONS AND ROBOTICS, Book Series: Mechanisms and Machine Science, Volume: 46, Pages: 3-13, Joint International Conference of the 12th International Conference on Mechanisms and Mechanical Transmissions (MTM) / 23rd International Conference on Robotics (Robotics), OCT 26-27, 2016, Aachen, GERMANY, ISSN: 2211-0984, ISBN: 978-3-319-45450-4; 978-3-319-45449-8, Published: 2017;
180. Miclau, M., Miclau, N., Banica, R., Ursu, D. Effect of polymorphism on photovoltaic performance of CuAlO<sub>2</sub> delafossite nanomaterials for p-type dye-sensitized solar cells application, MATERIALS TODAY-PROCEEDINGS, Volume: 4, Issue: 7, Pages: 6975-6981, Part: 1, 13th International Conference on Nanosciences and Nanotechnologies (NN) / 9th International Symposium on Flexible Organic Electronics (ISFOE), JUL 04-07, 2016, Thessaloniki, GREECE, ISSN: 2214-7853, Published: 2017;
181. Miklos, I.Z., Miklos, C., Alic, C. Dynamic simulation of road vehicle door window regulator mechanism of cross arm type, INTERNATIONAL CONFERENCE ON APPLIED SCIENCES (ICAS2016), Book Series: IOP Conference Series-Materials Science and Engineering, Volume: 163, Article Number: UNSP 012019, International Conference on Applied Sciences (ICAS), MAY 25-27, 2016, Hunedoara, ROMANIA, ISSN: 1757-8981, Published: 2017;
182. Mischie, S., Muntean, A. Distance estimation through stereoscopy using BeagleBoneBlack and RaspberryPi, 2017 INTERNATIONAL SYMPOSIUM ON SIGNALS, CIRCUITS AND SYSTEMS (ISSCS), International Symposium on Signals, Circuits and Systems (ISSCS), JUL 13-14, 2017, Iasi, ROMANIA, ISBN: 978-1-5386-0674-2, Published: 2017;
183. Mituletu, I.C., Borza, A., Bizau, V.I. Design and Optimization of the Cooling Process to Rapid Control a SMA-Based Wave Generator, 2017 10TH INTERNATIONAL SYMPOSIUM ON ADVANCED TOPICS IN ELECTRICAL ENGINEERING (ATEE), Book Series: International Symposium on Advanced Topics in Electrical Engineering, Pages: 872-875, 10th International Symposium on Advanced Topics in Electrical Engineering (ATEE), MAR 23-25, 2017, Bucharest, ROMANIA, ISSN: 1843-8571, ISBN: 978-1-5090-5160-1, Published: 2017;

184. Mocofan, M. IMPROVEMENT OF COURSES INTERACTIVITY USING WEB AND MOBILE TECHNOLOGIES FOR INSTANT FEEDBACK, INTED2017: 11TH INTERNATIONAL TECHNOLOGY, EDUCATION AND DEVELOPMENT CONFERENCE, Book Series: INTED Proceedings, Pages: 6649-6654, 11th International Conference on Technology, Education and Development (INTED), MAR 06-08, 2017, Valencia, SPAIN, ISSN: 2340-1079, ISBN: 978-84-617-8491-2, Published: 2017;
185. Mocofan, M., Ciuclea, C. STUDENT TECHNOLOGIES PROPOSALS TO BE USED IN THE DEVELOPMENT OF OPEN COURSES, 10TH INTERNATIONAL CONFERENCE OF EDUCATION, RESEARCH AND INNOVATION (ICERI2017), Book Series: ICERI Proceedings, Pages: 2814-2818, 10th Annual International Conference of Education, Research and Innovation (ICERI), NOV 16-18, 2017, Seville, SPAIN, ISSN: 2340-1095, ISBN: 978-84-697-6957-7, Published: 2017;
186. Modler, N., Winkler, A., Filippatos, A., Lovasz, E.C., Margineanu, D.T. Dynamic Behavior of Active Lightweight Compliant Mechanisms with Integrated Piezoceramic Actuators by Under- and Overcritical Periodic Excitation, MICROACTUATORS AND MICROMECHANISMS, MAMM-2016, Book Series: Mechanisms and Machine Science, Volume: 45, Pages: 213-225, 4th Conference on Microactuators and Micromechanisms (MAMM), OCT 05-07, 2016, Ilmenau, GERMANY, ISSN: 2211-0984, ISBN: 978-3-319-45387-3; 978-3-319-45386-6, Published: 2017;
187. Moldovan, C.E., Perju, D., Lovasz, E.C., Modler, K.H., Maniu, I. On the Kinematic Analysis of a Sixth Class Mechanism, NEW ADVANCES IN MECHANISMS, MECHANICAL TRANSMISSIONS AND ROBOTICS, Book Series: Mechanisms and Machine Science, Volume: 46, Pages: 47-57, Joint International Conference of the 12th International Conference on Mechanisms and Mechanical Transmissions (MTM) / 23rd International Conference on Robotics (Robotics), OCT 26-27, 2016, Aachen, GERMANY, ISSN: 2211-0984, ISBN: 978-3-319-45450-4; 978-3-319-45449-8, Published: 2017;
188. Molnar, L., Gontean, L. ASIC Validation Architectures Hardware versus Simulation, 2017 21ST INTERNATIONAL CONFERENCE ON SYSTEM THEORY, CONTROL AND COMPUTING (ICSTCC), Book Series: International Conference on System Theory Control and Computing, Pages: 671-676, 21st International Conference on System Theory, Control and Computing (ICSTCC), OCT 19-21, 2017, Sinaia, ROMANIA, ISSN: 2372-1618, ISBN: 978-1-5386-3842-2, Published: 2017;
189. Molnar, L., Gontean, A., Kotlar, A., Svasta, P. Simulation Model for Automotive High Pressure Fuel Pump, 2017 IEEE 23RD INTERNATIONAL SYMPOSIUM FOR DESIGN AND TECHNOLOGY IN ELECTRONIC PACKAGING (SIITME), Pages: 231-234, 23rd IEEE International Symposium for Design and Technology in Electronic Packaging (SIITME), OCT 26-29, 2017, Constanta, ROMANIA, ISBN: 978-1-5386-1626-0, Published: 2017;
190. Moscovici, A.M., Brebu, F.M., Bala, A.C. Geospatial Data Acquisitions Using 3D Laser Scanning Technology in the Context of Monitoring Mines, MODERN TECHNOLOGIES FOR THE 3RD MILLENNIUM, Pages: 33-38, 16th National Technical-Scientific Conference on Modern Technologies for the 3rd Millennium, MAR 23-24, 2017, Oradea, ROMANIA, ISBN: 978-88-87729-41-2, Published: 2017;
191. Moscovici, A.M., Grecea, C. Geomatics, Support for an Efficient Urban Planning, WORLD MULTIDISCIPLINARY CIVIL ENGINEERING-ARCHITECTURE-URBAN PLANNING SYMPOSIUM – WMCAUS, Book Series: IOP Conference Series-Materials Science and Engineering, Volume: 245, Article Number: UNSP 052041, World Multidisciplinary Civil Engineering-Architecture-Urban Planning Symposium (WMCAUS), JUN 12-16, 2017, Prague, CZECH REPUBLIC, ISSN: 1757-8981, Published: 2017;
192. Mosoarca, M., Apostol, I., Stoian, V. Modern Consolidation Solutions for Buildings with Historical Value. Part II: Masonry Structures, MODERN TECHNOLOGIES FOR THE 3RD MILLENNIUM, Pages: 209-214, 16th National Technical-Scientific Conference on Modern Technologies for the 3rd Millennium, MAR 23-24, 2017, Oradea, ROMANIA, ISBN: 978-88-87729-41-2, Published: 2017;
193. Muntean, D.M., Ungureanu, V., Petran, I., Georgescu, M. Large Prefabricated Concrete Panels Collective Dwellings from the 1970s: Context and Improvements, WORLD MULTIDISCIPLINARY CIVIL ENGINEERING-ARCHITECTURE-URBAN PLANNING SYMPOSIUM – WMCAUS, Book Series: IOP Conference Series-Materials Science and Engineering, Volume: 245, Article Number: UNSP 052050, World Multidisciplinary Civil Engineering-Architecture-Urban Planning Symposium (WMCAUS), JUN 12-16, 2017, Prague, CZECH REPUBLIC, ISSN: 1757-8981, Published: 2017;
194. Murvay, P.S., Groza, B. DoS Attacks on Controller Area Networks by Fault Injections from the Software Layer, PROCEEDINGS OF THE 12TH INTERNATIONAL CONFERENCE ON AVAILABILITY, RELIABILITY AND SECURITY (ARES 2017), Article Number: UNSP A71, 12th International Conference on Availability, Reliability and Security (ARES), AUG 29-SEP 01, 2017, Calabria, ITALY, ISBN: 978-1-4503-5257-4, Published: 2017;



195. Muscalagiu, C.G., Muscalagiu, I., Muscalagiu, D.M. The curving calculation of a mechanical device attached to a multi-storey car park, INTERNATIONAL CONFERENCE ON APPLIED SCIENCES (ICAS2016), Book Series: IOP Conference Series-Materials Science and Engineering, Volume: 163, Article Number: UNSP 012051, International Conference on Applied Sciences (ICAS), MAY 25-27, 2016, Hunedoara, ROMANIA, ISSN: 1757-8981, Published: 2017;
196. Nafornta, C., Isar, A., Matanie, N., Caba, C. Solution of a Big Data Problem. Simulator for Denoising of Single Look Complex SAR Images, 2017 INTERNATIONAL SYMPOSIUM ON SIGNALS, CIRCUITS AND SYSTEMS (ISSCS), International Symposium on Signals, Circuits and Systems (ISSCS), JUL 13-14, 2017, Iasi, ROMANIA, ISBN: 978-1-5386-0674-2, Published: 2017;
197. Nagy, V., Mnerie, G.V., Mnerie, D. Bodin, F. STUDY OF TECHNICAL AND HUMAN INFLUENCE FACTORS ON THE EFFICIENT USING OF HOG CASINGS PROCESSING EQUIPMENT, ACTUAL TASKS ON AGRICULTURAL ENGINEERING, Book Series: Actual Tasks on Agricultural Engineering-Zagreb, Volume: 45, Pages: 385-391, 45th International Symposium on Agricultural Engineering, FEB 21-24, 2017, Opatija, CROATIA, ISSN: 1848-4425, Published: 2017;
198. Negrisanu, D., Havasi, B., Florescu, D. Teaching Architecture to Children. (In) Between Metaphor and Pragmatism, EDU WORLD 7TH INTERNATIONAL CONFERENCE, Book Series: European Proceedings of Social and Behavioural Sciences, Volume: 23, Pages: 558-565, 7th International Edu World Conference (Edu World), NOV 04-05, 2016, Pitesti, ROMANIA, ISSN: 2357-1330, Published: 2017;
199. Nenu, P.F., Maris, S.A., Forgacs, L., Maris, S. USE OF BIOMASS IN COAL STEAM BOILERS, ACTUAL TASKS ON AGRICULTURAL ENGINEERING, Book Series: Actual Tasks on Agricultural Engineering-Zagreb, Volume: 45, Pages: 473-479, 45th International Symposium on Agricultural Engineering, FEB 21-24, 2017, Opatija, CROATIA, ISSN: 1848-4425, Published: 2017;
200. Nicola, S., Virag, I., Stoicu-Tivadar, L. VR Medical Gamification for Training and Education, HEALTH INFORMATICS MEETS EHEALTH: DIGITAL INSIGHT - INFORMATION-DRIVEN HEALTH & CARE, Book Series: Studies in Health Technology and Informatics, Volume: 236, Pages: 97-103, PubMed ID: 28508784, 11th Annual Conference on Health Informatics Meets eHealth (eHealth), MAY 23-24, 2017, Schloss Schonbrunn, AUSTRIA, ISSN: 0926-9630, eISSN: 1879-8365, ISBN: 978-1-61499-759-7; 978-1-61499-758-0, Published: 2017;
201. Nicolae, I.V., Socoliuc, V. High Amplitude Oscillating Magnetic Field Applicator for Remote Magnetic Nanoparticle Detection, TIM17 PHYSICS CONFERENCE, Book Series: AIP Conference Proceedings, Volume: 1916, Article Number: UNSP 040012, 17th Physics Conference, MAY 25-27, 2017, Timisoara, ROMANIA, ISSN: 0094-243X, ISBN: 978-0-7354-1608-6, Published: 2017;
202. Nicoloiu, R., Ionel, I., Voda, I. Evolution of Green Certificate Support Scheme for Promoting Renewable Energy in Romania, 2017 8TH INTERNATIONAL CONFERENCE ON ENERGY AND ENVIRONMENT (CIEM), Book Series: International Conference on Energy and Environment, Pages: 359-362, 8th International Conference on ENERGY and ENVIRONMENT (CIEM), OCT 19-20, 2017, Bucharest, ROMANIA, ISSN: 2067-0907, ISBN: 978-1-5386-3943-6, Published: 2017;
203. Nimara, S., Nandra, M., Bogdan, R. Low-Power Wireless Data Acquisition System, 2017 25TH TELECOMMUNICATION FORUM (TELFOR), Pages: 289-292, 25th Telecommunication Forum (TELFOR), NOV 21-22, 2017, Belgrade, SERBIA, ISBN: 978-1-5386-3073-0, Published: 2017;
204. Nimara, S., Popa, D.B., Bogdan, R. Automotive Instrument Cluster Screen Content Validation, 2017 25TH TELECOMMUNICATION FORUM (TELFOR), Pages: 629-632, 25th Telecommunication Forum (TELFOR), NOV 21-22, 2017, Belgrade, SERBIA, ISBN: 978-1-5386-3073-0, Published: 2017;
205. Nyiredi, A., Iacob, E.R., Iacob, D., Lihu, A., Moza, A., Ilie, C. When is the Neonate in Pain?, PROCEEDINGS OF THE 14TH NATIONAL CONGRESS OF UROGYNECOLOGY AND THE NATIONAL CONFERENCE OF THE ROMANIAN ASSOCIATION FOR THE STUDY OF PAIN, Pages: 511-514, National Conference of the Romanian-Association-for-the-Study-of-Pain, OCT 26-27, 2017, Bucharest, ROMANIA, ISBN: 978-88-95922-98-0, Published: 2017;
206. Olariu, F.A., Frigura-Iliasa, M., Frigura-Iliasa, F.M., Vatau, D., Andea, P. Experimental Study about the Concentration of Cr2O3 and MnO2 inside a New Metal Oxide Varistor Material, 2017 10TH INTERNATIONAL CONFERENCE ON ELECTRICAL AND ELECTRONICS ENGINEERING (ELECO), Pages: 402-405, 10th International Conference on Electrical and Electronics Engineering (ELECO), NOV 30-DEC 02, 2017, Bursa, TURKEY, ISBN: 978-1-5386-1723-6, Published: 2017;

207. Onchis, D., Istin, C., Real, P. Space-Variant Gabor Decomposition for Filtering 3D Medical Images, COMPUTER ANALYSIS OF IMAGES AND PATTERNS: 17TH INTERNATIONAL CONFERENCE, CAIP 2017, PT II, Book Series: Lecture Notes in Computer Science, Volume: 10425, Pages: 455-461, 17th International Conference on Computer Analysis of Images and Patterns (CAIP), AUG 22-24, 2017, Ystad, SWEDEN, ISSN: 0302-9743, eISSN: 1611-3349, ISBN: 978-3-319-64698-5; 978-3-319-64697-8, Published: 2017;
208. Oprea, O.B., Gaceu, L., Tucu, D. VALORISATION OF WINERY WASTE BY USING GSP (GRAPE SEED POWDER) AS FLOUR SUBSTITUTION IN BAKERY INDUSTRY, ACTUAL TASKS ON AGRICULTURAL ENGINEERING, Book Series: Actual Tasks on Agricultural Engineering-Zagreb, Volume: 45, Pages: 371-376, 45th International Symposium on Agricultural Engineering, FEB 21-24, 2017, Opatija, CROATIA, ISSN: 1848-4425, Published: 2017;
209. Opritoiu, F., Jurj, S.L., Vladutiu, M. Technological solutions for throughput improvement of a Secure Hash Algorithm-256 Engine, 2017 IEEE 23RD INTERNATIONAL SYMPOSIUM FOR DESIGN AND TECHNOLOGY IN ELECTRONIC PACKAGING (SIITME), Pages: 159-164, 23rd IEEE International Symposium for Design and Technology in Electronic Packaging (SIITME), OCT 26-29, 2017, Constanta, ROMANIA, ISBN: 978-1-5386-1626-0, Published: 2017;
210. Orzen, S.N., Babii, S. Data Packet Header Actions in Fault Tolerance of Persistent Routing Sessions, 2017 IEEE 15TH INTERNATIONAL SYMPOSIUM ON INTELLIGENT SYSTEMS AND INFORMATICS (SISY), Book Series: International Symposium on Intelligent Systems and Informatics, Pages: 193-196, 15th IEEE International Symposium on Intelligent Systems and Informatics (SISY), SEP 14-16, 2017, Subotica, SERBIA, ISSN: 1949-047X, ISBN: 978-1-5386-3855-2, Published: 2017;
211. Orzen, S.N., Babii, S. Network Events in the Dynamic Selection of Real-Time Session Fault Tolerant Routes, 2017 IEEE 21ST INTERNATIONAL CONFERENCE ON INTELLIGENT ENGINEERING SYSTEMS (INES), Book Series: IEEE International Conference on Intelligent Engineering Systems, Pages: 301-304, 21st IEEE International Conference on Intelligent Engineering Systems (INES), OCT 20-23, 2017, Larnaca, CYPRUS, ISSN: 1562-5850, ISBN: 978-1-4799-7677-5, Published: 2017;
212. Osaci, M., Cacciola, M. Specific loss power in superparamagnetic hyperthermia: nanofluid versus composite, INTERNATIONAL CONFERENCE ON APPLIED SCIENCES (ICAS2016), Book Series: IOP Conference Series-Materials Science and Engineering, Volume: 163, Article Number: UNSP 012008, International Conference on Applied Sciences (ICAS), MAY 25-27, 2016, Hunedoara, ROMANIA, ISSN: 1757-8981, Published: 2017;
213. Pamintas, E., Banciu, F.V. The preparation for being a researcher in Romania today, 4TH INTERNATIONAL CONFERENCE ON COMPUTING AND SOLUTIONS IN MANUFACTURING ENGINEERING 2016 - COSME'16, Book Series: MATEC Web of Conferences, Volume: 94, Article Number: UNSP 07008, 4th International Conference on Computing and Solutions in Manufacturing Engineering (CoSME), NOV 03-04, 2016, Brasov, ROMANIA, ISSN: 2261-236X, Published: 2017;
214. Pamintas, E. The tool profile and the localization of the revolution axis for irregular outline milling, 4TH INTERNATIONAL CONFERENCE ON COMPUTING AND SOLUTIONS IN MANUFACTURING ENGINEERING 2016 - COSME'16, Book Series: MATEC Web of Conferences, Volume: 94, Article Number: UNSP 05005, 4th International Conference on Computing and Solutions in Manufacturing Engineering (CoSME), NOV 03-04, 2016, Brasov, ROMANIA, ISSN: 2261-236X, Published: 2017;
215. Pana, A., Molnar-Matei, F., Baloi, A., Radulian, A., Mocioi, N., Dumitrescu, G. A Smart Solution For a Smart Grid: Unbalanced Reactive Power Compensation, 2017 ELECTRIC VEHICLES INTERNATIONAL CONFERENCE (EV), Electric Vehicles International Conference (EV), OCT 05-06, 2017, Bucharest, ROMANIA, ISBN: 978-1-5386-2382-4, Published: 2017;
216. Panoiu, C., Rob, R., Rusu-Anghel, S. Real Time System for Measuring the Pantograph Vertically Movement, 2017 IEEE 15TH INTERNATIONAL CONFERENCE ON INDUSTRIAL INFORMATICS (INDIN), Book Series: IEEE International Conference on Industrial Informatics INDIN, Pages: 957-962, 15th IEEE International Conference on Industrial Informatics (INDIN), JUL 24-26, 2017, Emden, GERMANY, ISSN: 1935-4576, ISBN: 978-1-5386-0837-1, Published: 2017;
217. Partene, E., Petrus, C., Bindean, A., Fekete-Nagy, L., Stoian, V. Shear Capacity for Masonry Walls Strengthened with FRP Materials, MODERN TECHNOLOGIES FOR THE 3RD MILLENNIUM, Pages: 221-224, 16th National Technical-Scientific Conference on Modern Technologies for the 3rd Millennium, MAR 23-24, 2017, Oradea, ROMANIA, ISBN: 978-88-87729-41-2, Published: 2017;

218. Pascal, D.T., Muntean, R., Kazamer, N., Marginean, G., Brandl, W., Serban, V.A. CHARACTERISTICS OF HIGH TEMPERATURE VACUUM BRAZED WC-Co-NiCrBSi FUNCTIONAL COMPOSITE COATINGS, 8TH INTERNATIONAL CONFERENCE ON NANOMATERIALS - RESEARCH & APPLICATION (NANOCON 2016), Pages: 775-780, 8th International Conference on Nanomaterials - Research and Application (NANOCON), OCT 19-21, 2016, Brno, CZECH REPUBLIC, ISBN: 978-80-87294-71-0, Published: 2017;
219. Pater, L., Izvercian, M., Ivascu, L. A Statistical Study on Consumer's Perception of Sustainable Products, PROCEEDINGS OF THE INTERNATIONAL CONFERENCE ON NUMERICAL ANALYSIS AND APPLIED MATHEMATICS 2016 (ICNAAM-2016), Book Series: AIP Conference Proceedings, Volume: 1863, Article Number: UNSP 430004-1, International Conference on Numerical Analysis and Applied Mathematics (ICNAAM), SEP 19-25, 2016, Rhodes, GREECE, ISSN: 0094-243X, ISBN: 978-0-7354-1538-6, Published: 2017;
220. Patrascu, C., Rat, C.L., Hulea, D., Vitan, D., Muntean, N. Mixed PV-Wind Small Power Microgrid, 2017 INTERNATIONAL CONFERENCE ON OPTIMIZATION OF ELECTRICAL AND ELECTRONIC EQUIPMENT (OPTIM) & 2017 INTL AEGEAN CONFERENCE ON ELECTRICAL MACHINES AND POWER ELECTRONICS (ACEMP), Pages: 699-704, International Conference on Optimization of Electrical and Electronic Equipment (OPTIM) / Intl Aegean Conference on Electrical Machines and Power Electronics (ACEMP), MAY 25-27, 2017, Brasov, ROMANIA, ISBN: 978-1-5090-4489-4, Published: 2017;
221. Paulescu, E., Iman, V., Dughir, C., Stefu, N., Paulescu, M. A Simplified but Accurate UV Index Model, TIM17 PHYSICS CONFERENCE, Book Series: AIP Conference Proceedings, Volume: 1916, Article Number: UNSP 040010, 17th Physics Conference, MAY 25-27, 2017, Timisoara, ROMANIA, ISSN: 0094-243X, ISBN: 978-0-7354-1608-6, Published: 2017;
222. Paulescu, M., Vizman, D., Lascu, M., Negrila, R., Stef, M. Experimental Study of Proton Irradiation Effect on Silicon Solar Cells, TIM15-16 PHYSICS CONFERENCE, Book Series: AIP Conference Proceedings, Volume: 1796, Article Number: UNSP 040010-1, TIM15-16 Physics Conference, MAY 26-28, 2016, Timisoara, ROMANIA, ISSN: 0094-243X, ISBN: 978-0-7354-1462-4, Published: 2017;
223. Paun, A.C., Vatau, D., Frigura-Iliasa, F.M., Andea, P., Frigura-Iliasa, M., Balcu, F.I. New Manufacturing Process for the Metal Oxide Varistors used on Low Voltage Surge-Arresters, PROCEEDINGS OF THE 2017 18TH INTERNATIONAL SCIENTIFIC CONFERENCE ON ELECTRIC POWER ENGINEERING (EPE), Book Series: International Scientific Conference on Electric Power Engineering, Pages: 351-354, 18th International Scientific Conference on Electric Power Engineering (EPE), MAY 17-19, 2017, Kouty nad Desnou, CZECH REPUBLIC, ISSN: 2376-5623, ISBN: 978-1-5090-6406-9, Published: 2017;
224. Paunescu, V., Calin, M., Manea, R., Moscovici, A., Salagean, T. GIS in Active Monitoring of Green Spaces, MODERN TECHNOLOGIES FOR THE 3RD MILLENNIUM, Pages: 73-78, 16th National Technical-Scientific Conference on Modern Technologies for the 3rd Millennium, MAR 23-24, 2017, Oradea, ROMANIA, ISBN: 978-88-87729-41-2, Published: 2017;
225. Petrenci, R., Frigura-Iliasa, M., Frigura-Iliasa, F.M., Mirica, M., Balcu, F. Experimental Study about the Sintering Temperature of a New Metal Oxide Varistor Material, 2017 10TH INTERNATIONAL CONFERENCE ON ELECTRICAL AND ELECTRONICS ENGINEERING (ELECO), Pages: 398-401, 10th International Conference on Electrical and Electronics Engineering (ELECO), NOV 30-DEC 02, 2017, Bursa, TURKEY, ISBN: 978-1-5386-1723-6, Published: 2017;
226. Petrus, C., Partene, E., Mosoarca, M., Stoian, V. Effect of Consolidating Materials on the Out of Plane Behaviour of Masonry Infills. A Design Approach, MODERN TECHNOLOGIES FOR THE 3RD MILLENNIUM, Pages: 225-232, 16th National Technical-Scientific Conference on Modern Technologies for the 3rd Millennium, MAR 23-24, 2017, Oradea, ROMANIA, ISBN: 978-88-87729-41-2, Published: 2017;
227. Pisleaga, M., Badaluta-Minda, C., Eles, G., Popescu, D. Hydrographic Basins Analysis Using Digital Terrain Modelling, WORLD MULTIDISCIPLINARY CIVIL ENGINEERING-ARCHITECTURE-URBAN PLANNING SYMPOSIUM - WMCAUS, Book Series: IOP Conference Series-Materials Science and Engineering, Volume: 245, Article Number: UNSP 062034, World Multidisciplinary Civil Engineering-Architecture-Urban Planning Symposium (WMCAUS), JUN 12-16, 2017, Prague, CZECH REPUBLIC, ISSN: 1757-8981, Published: 2017;
228. Pop, C., Lovasz, E.C., Pop, F., Davidescu, A., Grigorescu, S.M. Matlab GUI for SVAJ Cam Analysis Diagrams, NEW ADVANCES IN MECHANISMS, MECHANICAL TRANSMISSIONS AND ROBOTICS, Book Series: Mechanisms and Machine Science, Volume: 46, Pages: 37-45, Joint International Conference of the 12th International Conference on Mechanisms and Mechanical Transmissions (MTM) / 23rd International Conference on Robotics (Robotics), OCT 26-27, 2016, Aachen, GERMANY, ISSN: 2211-0984, ISBN: 978-3-319-45450-4; 978-3-319-45449-8, Published: 2017;

229. Pop, F., Lovasz, E.C., Pop, C., Dolga, V., Grigorescu, S.M. Trajectory Analysis for Modified Jansen Leg Mechanism Configuration, NEW ADVANCES IN MECHANISMS, MECHANICAL TRANSMISSIONS AND ROBOTICS, Book Series: Mechanisms and Machine Science, Volume: 46, Pages: 409-416, Joint International Conference of the 12th International Conference on Mechanisms and Mechanical Transmissions (MTM) / 23rd International Conference on Robotics (Robotics), OCT 26-27, 2016, Aachen, GERMANY, ISSN: 2211-0984, ISBN: 978-3-319-45450-4; 978-3-319-45449-8, Published: 2017;
230. Pop, N., Cira, O., Duma, V.F. Analytic functions of optical choppers for Gaussian laser beams, DIGITAL OPTICAL TECHNOLOGIES 2017, Book Series: Proceedings of SPIE, Volume: 10335, Article Number: UNSP 103351P, Conference on Digital Optical Technologies, JUN 26-28, 2017, Munich, GERMANY, ISSN: 0277-786X, eISSN: 1996-756X, ISBN: 978-1-5106-1116-0; 978-1-5106-1115-3, Published: 2017;
231. Pop, N., Iacob, F., Mezei, J.Z., Motapon, O., Niyonzima, S., Kashinski, D.O., Talbi, D., Hickman, A.P., Schneider, I.F. Reactive Collisions of Electrons with H-2(+), HD+, BeH+, BeD+ and SH+, TIM17 PHYSICS CONFERENCE, Book Series: AIP Conference Proceedings, Volume: 1916, Article Number: UNSP 020013, 17th Physics Conference, MAY 25-27, 2017, Timisoara, ROMANIA, ISSN: 0094-243X, ISBN: 978-0-7354-1608-6, Published: 2017;
232. Pop, N., Mezei, Z., Motapon, O., Niyonzima, S., Chakrabarti, K., Colboc, F., Boata, R., Epee, M.D.E., Schneider, I.F. Reactive Collisions of Electrons with Molecular Cations: Application to H-2(+), BeH+, BF+, TIM15-16 PHYSICS CONFERENCE, Book Series: AIP Conference Proceedings, Volume: 1796, Article Number: UNSP 020014, TIM15-16 Physics Conference, MAY 26-28, 2016, Timisoara, ROMANIA, ISSN: 0094-243X, ISBN: 978-0-7354-1462-4, Published: 2017;
233. Popa, C.A. Complex-Valued Convolutional Neural Networks for Real-Valued Image Classification, 2017 INTERNATIONAL JOINT CONFERENCE ON NEURAL NETWORKS (IJCNN), Book Series: IEEE International Joint Conference on Neural Networks (IJCNN), Pages: 816-822, International Joint Conference on Neural Networks (IJCNN), MAY 14-19, 2017, Anchorage, AK, ISSN: 2161-4393, ISBN: 978-1-5090-6182-2, Published: 2017;
234. Popa, C.A. Global Asymptotic Stability for Matrix-Valued Recurrent Neural Networks with Time Delays, 2017 INTERNATIONAL JOINT CONFERENCE ON NEURAL NETWORKS (IJCNN), Book Series: IEEE International Joint Conference on Neural Networks (IJCNN), Pages: 4474-4481, International Joint Conference on Neural Networks (IJCNN), MAY 14-19, 2017, Anchorage, AK, ISSN: 2161-4393, ISBN: 978-1-5090-6182-2, Published: 2017;
235. Popa, C.A. Octonion-Valued Bidirectional Associative Memories, 2017 INTERNATIONAL JOINT CONFERENCE ON NEURAL NETWORKS (IJCNN), Book Series: IEEE International Joint Conference on Neural Networks (IJCNN), Pages: 783-787, International Joint Conference on Neural Networks (IJCNN), MAY 14-19, 2017, Anchorage, AK, ISSN: 2161-4393, ISBN: 978-1-5090-6182-2, Published: 2017;
236. Popa, G.N., Dinis, C.M., Iagar, A., Popa, I. An experimental comparative analyse between three low capacity PLCs, INTERNATIONAL CONFERENCE ON APPLIED SCIENCES (ICAS2016), Book Series: IOP Conference Series-Materials Science and Engineering, Volume: 163, Article Number: UNSP 012034, International Conference on Applied Sciences (ICAS), MAY 25-27, 2016, Hunedoara, ROMANIA, ISSN: 1757-8981, Published: 2017;
237. Popa, G.N., Iagar, A., Dinis, C.M. Some Power Quality Issues in Power Substation from Residential and Educational Buildings, 2017 10TH INTERNATIONAL SYMPOSIUM ON ADVANCED TOPICS IN ELECTRICAL ENGINEERING (ATEE), Book Series: International Symposium on Advanced Topics in Electrical Engineering, Pages: 545-550, 10th International Symposium on Advanced Topics in Electrical Engineering (ATEE), MAR 23-25, 2017, Bucharest, ROMANIA, ISSN: 1843-8571, ISBN: 978-1-5090-5160-1, Published: 2017;
238. Pop-Calimanu, I.M., Lascu, D., Lica, S., Gurbina, M., Renken, F. A New Hybrid Boost-L Converter, 2017 INTERNATIONAL SYMPOSIUM ON POWER ELECTRONICS (EE), 19th International Symposium on Power Electronics (Ee), OCT 19-21, 2017, NOVI SAD, SERBIA, ISBN: 978-1-5386-3502-5, Published: 2017;
239. Popovici-Donici, M.C. SYSTEMATIC TYPOLOGIES OF NEOLITHIC CONSTRUCTIONS IN THE ROMANIAN BANAT, BASED ON A NEW METHOD OF ARCHITECTURAL RECASTING, 4TH INTERNATIONAL CONFERENCE ON EDUCATION AND SOCIAL SCIENCES (INTCESS 2017), Pages: 767-774, 4th International Conference on Education and Social Sciences (INTCESS), FEB 06-08, 2017, Istanbul, TURKEY, ISBN: 978-605-64453-9-2, Published: 2017;

240. Porojan, L., Porojan, S., Rusu, L., Bolos, A., Savencu, C. Experimental Analyses for The Mechanical Behavior of Pressed All-Ceramic Molar Crowns with Anatomical Design, 2017 INTERNATIONAL CONFERENCE ON MECHANICAL, AERONAUTICAL AND AUTOMOTIVE ENGINEERING (ICMAA 2017), Book Series: MATEC Web of Conferences, Volume: 108, Article Number: UNSP 02001, International Conference on Mechanical, Aeronautical and Automotive Engineering (ICMAA), FEB 25-27, 2017, Malacca, MALAYSIA, ISSN: 2261-236X, Published: 2017;
241. Potra, S. What Defines a Prosumer? An Insight in Participative Consumer Behaviour, PROCEEDINGS OF THE 5TH INTERNATIONAL CONFERENCE ON MANAGEMENT, LEADERSHIP AND GOVERNANCE (ICMLG 2017), Book Series: Proceedings of the International Conference on Management Leadership and Governance, Pages: 380-385, 5th International Conference on Management, Leadership and Governance (ICMLG), MAR 16-17, 2017, Johannesburg, SOUTH AFRICA, ISSN: 2049-6818, ISBN: 978-1-911218-27-2, Published: 2017;
242. Potra, S., Izvercian, M. Value Co-Creators in Today's Open Innovation. How Are They Like?, PROCEEDINGS OF THE 9TH EUROPEAN CONFERENCE ON INTELLECTUAL CAPITAL (ECIC 2017), Book Series: Proceedings of the European Conference on Intellectual Capital, Pages: 254-260, 9th European Conference on Intellectual Capital (ECIC), APR 06-07, 2017, Lisbon, PORTUGAL, ISSN: 2049-0933, ISBN: 978-1-911218-31-9, Published: 2017;
243. Precup, R.E., Bojan-Dragos, C.A., Hedrea, E.L., Borlea, I.D., Petriu, E.M. Evolving Fuzzy Models for Anti-lock Braking Systems, 2017 IEEE INTERNATIONAL CONFERENCE ON COMPUTATIONAL INTELLIGENCE AND VIRTUAL ENVIRONMENTS FOR MEASUREMENT SYSTEMS AND APPLICATIONS (CIVEMSA), Book Series: IEEE International Conference on Computational Intelligence and Virtual Environments for Measurement Systems and Applications, Pages: 48-53, IEEE International Conference on Computational Intelligence and Virtual Environments for Measurement Systems and Applications (CIVEMSA), JUN 26-28, 2017, Annecy, FRANCE, ISSN: 2377-9314, ISBN: 978-1-5090-4253-1, Published: 2017;
244. Precup, R.E., Bojan-Dragos, C.A., Hedrea, E.L., Rarinca, M.D., Petriu, E.M. Evolving Fuzzy Models for the Position Control of Magnetic Levitation Systems, PROCEEDINGS OF THE 2017 EVOLVING AND ADAPTIVE INTELLIGENT SYSTEMS (EAIS), Conference on Evolving and Adaptive Intelligent Systems (EAIS), MAY 31-JUN 02, 2017, Ljubljana, SLOVENIA, ISBN: 978-1-5090-6444-1, Published: 2017;
245. Prostean, G., Hutanu, A., Volker, S. Impact of agile methodologies on team capacity in automotive radio-navigation projects, INTERNATIONAL CONFERENCE ON APPLIED SCIENCES (ICAS2016), Book Series: IOP Conference Series-Materials Science and Engineering, Volume: 163, Article Number: UNSP 012013, International Conference on Applied Sciences (ICAS), MAY 25-27, 2016, Hunedoara, ROMANIA, ISSN: 1757-8981, Published: 2017;
246. Prostean, G., Volker, S., Hutanu, A. Change management methodologies trained for automotive infotainment projects, INTERNATIONAL CONFERENCE ON APPLIED SCIENCES (ICAS2016), Book Series: IOP Conference Series-Materials Science and Engineering, Volume: 163, Article Number: UNSP 012012, International Conference on Applied Sciences (ICAS), MAY 25-27, 2016, Hunedoara, ROMANIA, ISSN: 1757-8981, Published: 2017;
247. Radac, M.B., Precup, R.E., Roman, R.C. Anti-lock Braking Systems Data-Driven Control Using Q-Learning, 2017 IEEE 26TH INTERNATIONAL SYMPOSIUM ON INDUSTRIAL ELECTRONICS (ISIE), Book Series: Proceedings of the IEEE International Symposium on Industrial Electronics, Pages: 418-423, 26th IEEE International Symposium on Industrial Electronics (ISIE), JUN 18-21, 2017, Edinburgh, SCOTLAND, ISSN: 2163-5137, ISBN: 978-1-5090-1412-5, Published: 2017;
248. Radac, M.B., Precup, R.E., Roman, R.C. Multi Input-Multi Output Tank System Data-Driven Model Reference Control, 2017 13TH IEEE INTERNATIONAL CONFERENCE ON CONTROL & AUTOMATION (ICCA), Book Series: IEEE International Conference on Control and Automation ICCA, Pages: 1078-1083, 13th IEEE International Conference on Control & Automation (ICCA), JUL 03-06, 2017, Ohrid, MACEDONIA, ISSN: 1948-3449, ISBN: 978-1-5386-2679-5, Published: 2017;
249. Radu, D., Sedmak, A., Bancila, R. Structural integrity of a wind loaded cylindrical steel shell structure, 2ND INTERNATIONAL CONFERENCE ON STRUCTURAL INTEGRITY, ICSI 2017, Book Series: Procedia Structural Integrity, Volume: 5, Pages: 1213-1220, 2nd International Conference on Structural Integrity (ICSI), SEP 04-07, 2017, Funchal, PORTUGAL, ISSN: 2452-3216, Published: 2017;
250. Rallabandi, V., Taran, N., Ionel, D.M., Boldea, I.G. Axial-flux PM Synchronous Machines with Air-gap Profiling and Very High Ratio of Spoke Rotor Poles to Stator Concentrated Coils, 2017 IEEE INTERNATIONAL ELECTRIC MACHINES AND DRIVES CONFERENCE (IEMDC), IEEE International Electric Machines and Drives Conference (IEMDC), MAY 21-24, 2017, Miami, FL, ISBN: 978-1-5090-4281-4, Published: 2017;



251. Rallabandi, V., Taran, N., Ionel, D.M., Boldea, I.G. MAGNUS An Ultra-high Specific Torque PM Axial Flux Type Motor with Flux Focusing and Modulation, 2017 IEEE ENERGY CONVERSION CONGRESS AND EXPOSITION (ECCE), Book Series: IEEE Energy Conversion Congress and Exposition, Pages: 1234-1239, 2017 9th Annual IEEE Energy Conversion Congress & Exposition (ECCE), OCT 01-05, 2017, Cincinnati, OH, ISSN: 2329-3721, ISBN: 978-1-5090-2998-3, Published: 2017;
252. Ramescu, C., Frigura-Iliasa, F.M., Musuroi, S., Frigura-Iliasa, M. REFURBISHMENT PROJECT FOR COMMAND AND CONTROL OF A GRAIN TANK, ACTUAL TASKS ON AGRICULTURAL ENGINEERING, Book Series: Actual Tasks on Agricultural Engineering-Zagreb, Volume: 45, Pages: 539-545, 45th International Symposium on Agricultural Engineering, FEB 21-24, 2017, Opatija, CROATIA, ISSN: 1848-4425, Published: 2017;
253. Ratiu, S., Alexa, V., Kiss, I., Cioata, V. Experimental determination of the filling coefficient for an aspirated spark-ignition engine, INTERNATIONAL CONFERENCE ON APPLIED SCIENCES (ICAS2016), Book Series: IOP Conference Series-Materials Science and Engineering, Volume: 163, Article Number: UNSP 012038, International Conference on Applied Sciences (ICAS), MAY 25-27, 2016, Hunedoara, ROMANIA, ISSN: 1757-8981, Published: 2017;
254. Renken, F., Shen, W.S., Wang, C., Pop-Calimanu, I.M., Ciresan, A. Multiphase Hybrid Buck-Boost Converter with Wide Conversion Ratio, 2017 19TH EUROPEAN CONFERENCE ON POWER ELECTRONICS AND APPLICATIONS (EPE'17 ECCE EUROPE), Book Series: European Conference on Power Electronics and Applications, 19th European Conference on Power Electronics and Applications (EPE ECCE Europe), SEP 11-14, 2017, Warsaw, POLAND, ISSN: 2325-0313, ISBN: 978-9-0758-1527-6, Published: 2017;
255. Riemschneider, E., Bordeasu, I., Mitelea, I., Utu, I.D. CAVITATION EROSION OF GREY CAST IRON WITH PEARLITE MICROSTRUCTURE, METAL 2017: 26TH INTERNATIONAL CONFERENCE ON METALLURGY AND MATERIALS, Pages: 985-990, 26th International Conference on Metallurgy and Materials (METAL), MAY 24-26, 2017, Brno, CZECH REPUBLIC, ISBN: 978-80-87294-79-6, Published: 2017;
256. Rimescu, C., Frigura-Iliasa, F.M., Dolga, L., Filipescu, H., Nen, M. A New Solution for a Domestic Low Voltage Surge-Arrester, 2017 10TH INTERNATIONAL CONFERENCE ON ELECTRICAL AND ELECTRONICS ENGINEERING (ELECO), Pages: 394-397, 10th International Conference on Electrical and Electronics Engineering (ELECO), NOV 30-DEC 02, 2017, Bursa, TURKEY, ISBN: 978-1-5386-1723-6, Published: 2017;
257. Rob, R., Rusu-Anghel, S., Panoiu, C. Real Time System for Acquiring and Logging the Plan Position Using NI MyRIO Controller, 2017 2ND INTERNATIONAL MULTIDISCIPLINARY CONFERENCE ON COMPUTER AND ENERGY SCIENCE (SPLITECH), Pages: 58-63, 2nd International Multidisciplinary Conference on Computer and Energy Science (SpliTech), JUL 12-14, 2017, Split, CROATIA, ISBN: 978-9-5329-0071-2, Published: 2017;
258. Rob, R., Tirian, G.O., Panoiu, C. Temperature controlling system using embedded equipment, INTERNATIONAL CONFERENCE ON APPLIED SCIENCES (ICAS2016), Book Series: IOP Conference Series-Materials Science and Engineering, Volume: 163, Article Number: UNSP 012046, International Conference on Applied Sciences (ICAS), MAY 25-27, 2016, Hunedoara, ROMANIA, ISSN: 1757-8981, Published: 2017;
259. Rob, R., Tirian, G.O., Panoiu, M. LabVIEW application for motion tracking using USB camera, INNOVATIVE IDEAS IN SCIENCE 2016, Book Series: IOP Conference Series-Materials Science and Engineering, Volume: 200, Article Number: UNSP 012008, Conference on Innovative Ideas in Science, NOV 10-11, 2016, Baia Mare, ROMANIA, ISSN: 1757-8981, Published: 2017;
260. Robu, A., Crisan-Vida, M., Robu, N., Neagu, A. Management of Data Structures Generated During Simulations of the Evolution of Multicellular Systems, BIOINFORMATICS AND BIOMEDICAL ENGINEERING, IWBBIO 2017, PT II, Book Series: Lecture Notes in Bioinformatics, Volume: 10209, Pages: 325-336, 5th International Work-Conference on Bioinformatics and Biomedical Engineering (IWBBIO), APR 26-28, 2017, Granada, SPAIN, ISSN: 0302-9743, eISSN: 1611-3349, ISBN: 978-3-319-56154-7; 978-3-319-56153-0, Published: 2017;
261. Roman, D.L., Roman, M., Ciorsac, A., Ostafe, V., Isvoran, A. Prediction of the biochemical mechanisms of action and side effects of the anabolic steroids, EUROPEAN BIOPHYSICS JOURNAL WITH BIOPHYSICS LETTERS, Meeting Abstract: P-441, Volume: 46, Pages: S229-S229, Supplement: 1, 19th IUPAB Congress / 11th EBSA Congress, JUL 16-20, 2017, Edinburgh, SCOTLAND, ISSN: 0175-7571, eISSN: 1432-1017, Published: 2017;
262. Roman, R.C., Precup, R.E., Radac, M.B. Model-Free Fuzzy Control of Twin Rotor Aerodynamic Systems, 2017 25TH MEDITERRANEAN CONFERENCE ON CONTROL AND AUTOMATION (MED), Book Series: Mediterranean Conference on Control and Automation, Pages: 559-564, 25th Mediterranean Conference on Control and Automation (MED), JUL 03-06, 2017, Valletta, MALTA, ISSN: 2325-369X, ISBN: 978-1-5090-4533-4, Published: 2017;

263. Roman, R.C., Precup, R.E., Radac, M.B., Petriu, E.M. Takagi-Sugeno Fuzzy Controller Structures for Twin Rotor Aerodynamic Systems, 2017 IEEE INTERNATIONAL CONFERENCE ON FUZZY SYSTEMS (FUZZ-IEEE), Book Series: IEEE International Conference on Fuzzy Systems, IEEE International Conference on Fuzzy Systems (FUZZ-IEEE), JUL 09-12, 2017, Naples, ITALY, ISSN: 1098-7584, ISBN: 978-1-5090-6034-4, Published: 2017;
264. Rus, S., Mocan, M., Ivascu, L., Trandafir, N. THE BEHAVIOR OF CUSTOMERS REGARDING E-BANKING AND ITS IMPACT ON THE BANKING SECTOR, ICCSBS 2017 - THE ANNUAL INTERNATIONAL CONFERENCE ON COGNITIVE - SOCIAL, AND BEHAVIOURAL SCIENCES, Book Series: European Proceedings of Social and Behavioural Sciences, Volume: 20, Pages: 232-239, 5th Annual International Conference on Cognitive - Social, and Behavioural Sciences, JAN 09-11, 2017, Brno, CZECH REPUBLIC, ISSN: 2357-1330, Published: 2017;
265. Rus, S., Mocan, M., Ivascu, L., Turi, A., Artene, A., Vartolomei, M. Evaluation of Corporate Social Responsibility Activities in the Banking Industry, SUSTAINABLE ECONOMIC GROWTH, EDUCATION EXCELLENCE, AND INNOVATION MANAGEMENT THROUGH VISION 2020, VOLS I-VII, Pages: 2500-2511, 29th International-Business-Information-Management-Association Conference, MAY 03-04, 2017, Vienna, AUSTRIA, ISBN: 978-0-9860419-7-6, Published: 2017;
266. Rusu-Anghel, S., Ene, A. Influence of typical faults over the dynamic behavior of pantograph-catenary contact force in electric rail transport, INNOVATIVE IDEAS IN SCIENCE 2016, Book Series: IOP Conference Series-Materials Science and Engineering, Volume: 200, Article Number: UNSP 012056, Conference on Innovative Ideas in Science, NOV 10-11, 2016, Baia Mare, ROMANIA, ISSN: 1757-8981, Published: 2017;
267. Rusu-Anghel, S. Experimental research on mathematical modelling and unconventional control of clinker kiln in cement plants, INTERNATIONAL CONFERENCE ON APPLIED SCIENCES (ICAS2016), Book Series: IOP Conference Series-Materials Science and Engineering, Volume: 163, Article Number: UNSP 012037, International Conference on Applied Sciences (ICAS), MAY 25-27, 2016, Hunedoara, ROMANIA, ISSN: 1757-8981, Published: 2017;
268. Sabareanu, E. Assessment and Rehabilitation Issues Concerning Existing 70's Structural Stock, INTERNATIONAL CONFERENCE ON INNOVATIVE RESEARCH - ICIR EUROINVENT 2017, Book Series: IOP Conference Series-Materials Science and Engineering, Volume: 209, Article Number: 012100, International Conference on Innovative Research (ICIR Euroinvent), MAY 25-26, 2017, Iasi, ROMANIA, ISSN: 1757-8981, Published: 2017;
269. Sandru, L.A., Crainic, M.F., Savu, D., Moldovan, C., Dolga, V., Preitl, S. Robotic System Construction with Mechatronic Components Inverted Pendulum - Humanoid Robot, NINTH INTERNATIONAL CONFERENCE ON MACHINE VISION (ICMV 2016), Book Series: Proceedings of SPIE, Volume: 10341, Article Number: UNSP 103411J, 9th International Conference on Machine Vision (ICMV), NOV 18-20, 2016, Nice, FRANCE, ISSN: 0277-786X, eISSN: 1996-756X, ISBN: 978-1-5106-1132-0, Published: 2017;
270. Sarbu, I., Mirza, M., Crasmareanu, E. Performance of Radiant Heating Systems of Low-Energy Buildings, WORLD MULTIDISCIPLINARY CIVIL ENGINEERING-ARCHITECTURE-URBAN PLANNING SYMPOSIUM - WMCAUS, Book Series: IOP Conference Series-Materials Science and Engineering, Volume: 245, Article Number: UNSP 032088, World Multidisciplinary Civil Engineering-Architecture-Urban Planning Symposium (WMCAUS), JUN 12-16, 2017, CZECH REPUBLIC, ISSN: 1757-8981, Published: 2017;
271. Senila, M., Handabut, A., Crisan, A., Petran, I. Experimental Studies Regarding the Influence of the Connection between Steel and Concrete in Case of Eccentrically Braced Frames, MODERN TECHNOLOGIES FOR THE 3RD MILLENNIUM, Pages: 245-250, 16th National Technical-Scientific Conference on Modern Technologies for the 3rd Millennium, MAR 23-24, 2017, Oradea, ROMANIA, ISBN: 978-88-87729-41-2, Published: 2017;
272. Sicoe, O., Popa, M. Comparison metrics for the output of a mixed fixed point and floating point graphics pipeline, 2017 25TH TELECOMMUNICATION FORUM (TELFOR), Pages: 625-628, 25th Telecommunication Forum (TELFOR), NOV 21-22, 2017, Belgrade, SERBIA, ISBN: 978-1-5386-3073-0, Published: 2017;
273. Silaghi, A.M., Balan, C., Tolan, E., De Sabata, A. The Influence of measurement setups in Radiated Emissions testing, 2017 14TH INTERNATIONAL CONFERENCE ON ENGINEERING OF MODERN ELECTRIC SYSTEMS (EMES), Pages: 220-223, 14th International Conference on Engineering of Modern Electric Systems (EMES), JUN 01-02, 2017, ORADEA, ROMANIA, ISBN: 978-1-5090-6073-3, Published: 2017;
274. Simionescu, D., Mitelea, I., Burca, M. OPPORTUNITIES OF NARROW GAP MAG WELDING OF API 5L X65M STEEL PIPELINE, METAL 2017: 26TH INTERNATIONAL CONFERENCE ON METALLURGY AND MATERIALS, Pages: 699-704, 26th International Conference on Metallurgy and Materials (METAL), MAY 24-26, 2017, Brno, CZECH REPUBLIC, ISBN: 978-80-87294-79-6, Published: 2017;

275. Simon, N., Mitelea, I., Burca, M., Utu, I.D. PARTICULARITIES OF CMT/CMTF BRAZE - WELDING PROCESS BETWEEN GALVANIZED STEEL AND ALUMINIUM ALLOY, METAL 2017: 26TH INTERNATIONAL CONFERENCE ON METALLURGY AND MATERIALS, Pages: 672-677, 26th International Conference on Metallurgy and Materials (METAL), MAY 24-26, 2017, Brno, CZECH REPUBLIC, ISBN: 978-80-87294-79-6, Published: 2017;
276. Simon, S., Stoian, C.E. DEVELOPING INTERPRETING SKILLS IN UNDERGRADUATE STUDENTS, 10TH INTERNATIONAL CONFERENCE OF EDUCATION, RESEARCH AND INNOVATION (ICERI2017), Book Series: ICERI Proceedings, Pages: 6180-6184, 10th Annual International Conference of Education, Research and Innovation (ICERI), NOV 16-18, 2017, Seville, SPAIN, ISSN: 2340-1095, ISBN: 978-84-697-6957-7, Published: 2017;
277. Smuleac, A., Nemes, I., Cretan, I.A., Nemes, N.S., Smuleac, L. Comparative Study of the Volumetric Methods Calculation Using GNSS Measurements, WORLD MULTIDISCIPLINARY CIVIL ENGINEERING-ARCHITECTURE-URBAN PLANNING SYMPOSIUM – WMCAUS, Book Series: IOP Conference Series-Materials Science and Engineering, Volume: 245, Article Number: UNSP 052020, World Multidisciplinary Civil Engineering-Architecture-Urban Planning Symposium (WMCAUS), JUN 12-16, 2017, Prague, CZECH REPUBLIC, ISSN: 1757-8981, Published: 2017;
278. Socalici, A., Pascu, L., Ardelean, E., Putan, V. Experiments on composites meant for making brake pads for the rolling stock, INTERNATIONAL CONFERENCE ON APPLIED SCIENCES (ICAS2016), Book Series: IOP Conference Series-Materials Science and Engineering, Volume: 163, Article Number: UNSP 012003, International Conference on Applied Sciences (ICAS), MAY 25-27, 2016, Hunedoara, ROMANIA, ISSN: 1757-8981, Published: 2017;
279. Stanciu, R., Sorandaru, C. Low-cost Visually Servoed Tracked Vehicle, 17TH IEEE INTERNATIONAL CONFERENCE ON SMART TECHNOLOGIES - IEEE EUROCON 2017 CONFERENCE PROCEEDINGS, Pages: 680-685, IEEE EUROCON -17th International Conference on Smart Technologies, JUL 06-08, 2017, Ohrid, MACEDONIA, ISBN: 978-1-5090-3843-5, Published: 2017;
280. Stangaciu, V., Oparlescu, V., Csereoka, P., Cioarga, R.D., Micea, M.V. Scalable Interconnected Home Automation System, 2017 21ST INTERNATIONAL CONFERENCE ON SYSTEM THEORY, CONTROL AND COMPUTING (ICSTCC), Book Series: International Conference on System Theory Control and Computing, Pages: 169-174, 21st International Conference on System Theory, Control and Computing (ICSTCC), OCT 19-21, 2017, Sinaia, ROMANIA, ISSN: 2372-1618, ISBN: 978-1-5386-3842-2, Published: 2017;
281. Stangaciu, V., Stanciu, M., Lupu, L., Micea, M.V., Cretu, V. Application layer protocol for IoT using Wireless Sensor Networks communication protocols, 2017 9TH INTERNATIONAL CONGRESS ON ULTRA MODERN TELECOMMUNICATIONS AND CONTROL SYSTEMS AND WORKSHOPS (ICUMT), Book Series: International Conference on Ultra Modern Telecommunications and Control Systems & Workshops, Pages: 425-430, 9th International Congress on Ultra Modern Telecommunications and Control Systems (ICUMT), NOV 06-08, 2017, Munich, GERMANY, ISSN: 2157-0221, ISBN: 978-1-5386-3435-6, Published: 2017;
282. Stefanica, A., Mihanca, P.F. XCore: Support for Developing Program Analysis Tools, 2017 IEEE 24TH INTERNATIONAL CONFERENCE ON SOFTWARE ANALYSIS, EVOLUTION, AND REENGINEERING (SANER), Pages: 462-466, 24th IEEE International Conference on Software Analysis, Evolution and Reengineering (SANER), FEB 20-24, 2017, Klagenfurt, AUSTRIA, ISBN: 978-1-5090-5501-2, Published: 2017;
283. Stirb, I. An Implementation of Loop Fusion for Improving Performance and Energy Consumption of Shared-Memory Parallel Codes, 2017 13TH IEEE INTERNATIONAL CONFERENCE ON INTELLIGENT COMPUTER COMMUNICATION AND PROCESSING (ICCP), Book Series: IEEE International Conference on Intelligent Computer Communication and Processing ICCP, Pages: 519-525, 13th IEEE International Conference on Intelligent Computer Communication and Processing (ICCP), SEP 07-09, 2017, Cluj Napoca, ROMANIA, ISSN: 2065-9946, ISBN: 978-1-5386-3368-7, Published: 2017;
284. Stoian, A.M., Maniu, I., Lovasz, E.C., Gruescu, C.M. Design Solutions to Simplify the Calibration of a Robotic Flexible Manufacturing System, NEW ADVANCES IN MECHANISMS, MECHANICAL TRANSMISSIONS AND ROBOTICS, Book Series: Mechanisms and Machine Science, Volume: 46, Pages: 229-238, Joint International Conference of the 12th International Conference on Mechanisms and Mechanical Transmissions (MTM) / 23rd International Conference on Robotics (Robotics), OCT 26-27, 2016, Aachen, GERMANY, ISSN: 2211-0984, ISBN: 978-3-319-45450-4; 978-3-319-45449-8, Published: 2017;
285. Stoian, C.E., Simon, S. THE INTEGRATION OF CULTURAL ASPECTS IN SYLLABUS DESIGN, 10TH INTERNATIONAL CONFERENCE OF EDUCATION, RESEARCH AND INNOVATION (ICERI2017), Book Series: ICERI Proceedings, Pages: 6346-6352, 10th Annual International Conference of Education, Research and Innovation (ICERI), NOV 16-18, 2017, Seville, SPAIN, ISSN: 2340-1095, ISBN: 978-84-697-6957-7, Published: 2017;



286. Strambeanu, N., Paunescu, D., Arghiriade, D., Demetrovici, L. PARALLEL AND CONSECUTIVE REACTIONS IN FUEL GAS COMBUSTION, 20TH INTERNATIONAL SYMPOSIUM - THE ENVIRONMENT AND THE INDUSTRY (SIMI 2017), Pages: 93-98, 20th International Symposium on The Environment and the Industry (SIMI), SEP 28-29, 2017, Bucharest, ROMANIA, ????, Published: 2017;
287. Svoboda, M., Biba, D., Musuroi, S., Ancuti, C.M., Sorandaru, C. Modeling of Squirrel Cage Induction Machine with S - function in MATLAB Simulink, 2017 14TH INTERNATIONAL CONFERENCE ON ENGINEERING OF MODERN ELECTRIC SYSTEMS (EMES), Pages: 176-179, 14th International Conference on Engineering of Modern Electric Systems (EMES), JUN 01-02, 2017, ORADEA, ROMANIA, ISBN: 978-1-5090-6073-3, Published: 2017;
288. Szabo, A., Binzar, T., Nadaban, S., Pater, F. Strict Inclusions between Some Classes of Fuzzy Relations, PROCEEDINGS OF THE INTERNATIONAL CONFERENCE ON NUMERICAL ANALYSIS AND APPLIED MATHEMATICS 2016 (ICNAAM-2016), Book Series: AIP Conference Proceedings, Volume: 1863, Article Number: UNSP 430007-1, International Conference on Numerical Analysis and Applied Mathematics (ICNAAM), SEP 19-25, 2016, Rhodes, GREECE, ISSN: 0094-243X, ISBN: 978-0-7354-1538-6, Published: 2017;
289. Szabo, R., Gontean, A. Optical Distance Measurement Analysis for Sun Tracker Robotic Arms at Different Luminous Fluxes using Six Sigma Methods, 2017 40TH INTERNATIONAL CONFERENCE ON TELECOMMUNICATIONS AND SIGNAL PROCESSING (TSP), Pages: 216-219, 40th International Conference on Telecommunications and Signal Processing (TSP), JUL 05-07, 2017, Barcelona, SPAIN, ISBN: 978-1-5090-3982-1, Published: 2017;
290. Szabo, R., Gontean, A. SCORBOT-ER III Robotic Arm Control with FPGA Using Image Processing with the Possibility to Use as Them as Sun Trackers, 2017 40TH INTERNATIONAL CONFERENCE ON TELECOMMUNICATIONS AND SIGNAL PROCESSING (TSP), Pages: 563-566, 40th International Conference on Telecommunications and Signal Processing (TSP), JUL 05-07, 2017, Barcelona, SPAIN, ISBN: 978-1-5090-3982-1, Published: 2017;
291. Szabo, R., Gontean, A. SCORBOT-ER III Robotic Arm Detection and Control with Color Recognition with the Possibility for Using in Sun Tracker Applications, 2017 1ST IEEE INTERNATIONAL CONFERENCE ON ENVIRONMENT AND ELECTRICAL ENGINEERING AND 2017 17TH IEEE INDUSTRIAL AND COMMERCIAL POWER SYSTEMS EUROPE (IEEE I&CPS EUROPE), 17th IEEE International Conference on Environment and Electrical Engineering (IEEE EEEIC) / 1st IEEE Industrial and Commercial Power Systems Europe (IEEE I&CPS Europe), JUN 06-09, 2017, Milan, ITALY, ISBN: 978-1-5386-3917-7, Published: 2017;
292. Szabo, R., Gontean, A. Sun Tracker Robotic Arm Optical Distance Measuring Algorithm Evaluation Using Six Sigma Methods, 2017 1ST IEEE INTERNATIONAL CONFERENCE ON ENVIRONMENT AND ELECTRICAL ENGINEERING AND 2017 17TH IEEE INDUSTRIAL AND COMMERCIAL POWER SYSTEMS EUROPE (IEEE I&CPS EUROPE), 17th IEEE International Conference on Environment and Electrical Engineering (IEEE EEEIC) / 1st IEEE Industrial and Commercial Power Systems Europe (IEEE I&CPS Europe), JUN 06-09, 2017, Milan, ITALY, ISBN: 978-1-5386-3917-7, Published: 2017;
293. Szoke, I.A., Stoicu-Tivadar, V., Lungeanu, D. A comparative study of using the LBC format for compressing medical images, 2017 IEEE 15TH INTERNATIONAL SYMPOSIUM ON APPLIED MACHINE INTELLIGENCE AND INFORMATICS (SAMI), Pages: 111-116, 15th IEEE International Symposium on Applied Machine Intelligence and Informatics (SAMI), JAN 26-28, 2017, Herlany, SLOVAKIA, ISBN: 978-1-5090-5655-2, Published: 2017;
294. Tanasa, C., Ciocan, T., Muntean, S. Numerical Assessment of Pulsating Water Jet in the Conical Diffusers, PROCEEDINGS OF THE INTERNATIONAL CONFERENCE OF COMPUTATIONAL METHODS IN SCIENCES AND ENGINEERING 2017 (ICCMSE-2017), Book Series: AIP Conference Proceedings, Volume: 1906, Article Number: UNSP 050002, International Conference of Computational Methods in Sciences and Engineering (ICCMSE), APR 21-25, 2017, Thessaloniki, GREECE, ISSN: 0094-243X, ISBN: 978-0-7354-1596-6, Published: 2017;
295. Tanase, D. DEVELOPING STUDENTS' BUSINESS AND PROFESSIONAL COMMUNICATION SKILLS - A SYLLABUS MODEL FOR ROMANIAN TECHNICAL UNIVERSITIES, INTED2017: 11TH INTERNATIONAL TECHNOLOGY, EDUCATION AND DEVELOPMENT CONFERENCE, Book Series: INTED Proceedings, Pages: 6883-6883, 11th International Conference on Technology, Education and Development (INTED), MAR 06-08, 2017, Valencia, SPAIN, ISSN: 2340-1079, ISBN: 978-84-617-8491-2, Published: 2017;
296. Tirian, G.O., Gheorghiu, C.A., Hepuț, T., Chioncel, C. Control system of water flow and casting speed in continuous steel casting, INNOVATIVE IDEAS IN SCIENCE 2016, Book Series: IOP Conference Series-Materials Science and Engineering, Volume: 200, Article Number: UNSP 012047, Conference on Innovative Ideas in Science, NOV 10-11, 2016, Baia Mare, ROMANIA, ISSN: 1757-8981, Published: 2017;

297. Tirian, G.O., Gheorghiu, C.A., Hepuț, T., Rob, R. Fuzzy control strategy for secondary cooling of continuous steel casting, INNOVATIVE IDEAS IN SCIENCE 2016, Book Series: IOP Conference Series–Materials Science and Engineering, Volume: 200, Article Number: UNSP 012046, Conference on Innovative Ideas in Science, NOV 10-11, 2016, Baia Mare, ROMANIA, ISSN: 1757-8981, Published: 2017;
298. Tisca, I.A., Anusca, D., Dumitrescu, C.D. Choosing the optimal wind turbine variant using the "ELECTRE" method, MODTECH INTERNATIONAL CONFERENCE – MODERN TECHNOLOGIES IN INDUSTRIAL ENGINEERING V, Book Series: IOP Conference Series–Materials Science and Engineering, Volume: 227, Article Number: UNSP 012129, 5th International Conference on Modern Technologies in Industrial Engineering (ModTech), JUN 14-17, 2017, Sibiu, ROMANIA, ISSN: 1757-8981, Published: 2017;
299. Todut, C., Dan, D., Stoian, V., Fofiu, M. Cut-out Weakening Investigation on Precast Reinforced Concrete Wall Panels, MODERN TECHNOLOGIES FOR THE 3RD MILLENNIUM, Pages: 279-284, 16th National Technical-Scientific Conference on Modern Technologies for the 3rd Millennium, MAR 23-24, 2017, Oradea, ROMANIA, ISBN: 978-88-87729-41-2, Published: 2017;
300. Topirceanu, A., Gamified learning: A role-playing approach to increase student in-class motivation, KNOWLEDGE-BASED AND INTELLIGENT INFORMATION & ENGINEERING SYSTEMS, Book Series: Procedia Computer Science, Volume: 112, Pages: 41-50, 21st International Conference on Knowledge - Based and Intelligent Information and Engineering Systems (KES), SEP 06-08, 2017, Marseille, FRANCE, ISSN: 1877-0509, Published: 2017;
301. Topirceanu, A., Grosseck, G. Decision tree learning used for the classification of student archetypes in online courses, KNOWLEDGE-BASED AND INTELLIGENT INFORMATION & ENGINEERING SYSTEMS, Book Series: Procedia Computer Science, Volume: 112, Pages: 51-60, 21st International Conference on Knowledge - Based and Intelligent Information and Engineering Systems (KES), SEP 06-08, 2017, Marseille, FRANCE, ISSN: 1877-0509, Published: 2017;
302. Torac, I., Tutelea, L.N., Boldea, I. Closed Slot Induction Machine Inductances and Rotor Resistance Characterization versus Current and Frequency via FEM, 2017 INTERNATIONAL CONFERENCE ON OPTIMIZATION OF ELECTRICAL AND ELECTRONIC EQUIPMENT (OPTIM) & 2017 INTL AEGEAN CONFERENCE ON ELECTRICAL MACHINES AND POWER ELECTRONICS (ACEMP), Pages: 275-280, International Conference on Optimization of Electrical and Electronic Equipment (OPTIM) / Intl Aegean Conference on Electrical Machines and Power Electronics (ACEMP), MAY 25-27, 2017, Brasov, ROMANIA, ISBN: 978-1-5090-4489-4, Published: 2017;
303. Totorean, A.F., Bernad, S.I., Hudrea, I.C., Susan-Resiga, R.F. Competitive Flow and Anastomosis Angle Influence on Bypass Hemodynamics in Unsteady Flow Conditions, PROCEEDINGS OF THE INTERNATIONAL CONFERENCE ON NUMERICAL ANALYSIS AND APPLIED MATHEMATICS 2016 (ICNAAM-2016), Book Series: AIP Conference Proceedings, Volume: 1863, Article Number: UNSP 030013-1, International Conference on Numerical Analysis and Applied Mathematics (ICNAAM), SEP 19-25, 2016, Rhodes, GREECE, ISSN: 0094-243X, ISBN: 978-0-7354-1538-6, Published: 2017;
304. Tudor, V., Grozav, A., Rogobete, G. Landslide: Mineralogical and Physical Investigation, WORLD MULTIDISCIPLINARY CIVIL ENGINEERING-ARCHITECTURE-URBAN PLANNING SYMPOSIUM - WMCAUS, Book Series: IOP Conference Series–Materials Science and Engineering, Volume: 245, Article Number: UNSP 032041, World Multidisciplinary Civil Engineering-Architecture-Urban Planning Symposium (WMCAUS), JUN 12-16, 2017, Prague, CZECH REPUBLIC, ISSN: 1757-8981, Published: 2017;
305. Turc, C.G., Carausu, C., Belgiu, G. Cost analysis in injection moulded plastic parts designing, MODTECH INTERNATIONAL CONFERENCE – MODERN TECHNOLOGIES IN INDUSTRIAL ENGINEERING V, Book Series: IOP Conference Series–Materials Science and Engineering, Volume: 227, Article Number: UNSP 012132, 5th International Conference on Modern Technologies in Industrial Engineering (ModTech), JUN 14-17, 2017, Sibiu, ROMANIA, ISSN: 1757-8981, Published: 2017;
306. Turi, A., Mocan, M., Ivascu, L., Goncalves, G. Managing Success: The Benefits of Marketing Effectiveness and Strategic Plan Adaptation in Automotive Industry, SUSTAINABLE ECONOMIC GROWTH, EDUCATION EXCELLENCE, AND INNOVATION MANAGEMENT THROUGH VISION 2020, VOLS I-VII, Pages: 2047-2059, 29th International-Business-Information-Management-Association Conference, MAY 03-04, 2017, Vienna, AUSTRIA, ISBN: 978-0-9860419-7-6, Published: 2017;
307. Turi, A., Mocan, M., Ivascu, L. THE ROLE OF EXPERIENCES IN MAINTAINING HIGH STANDARDS IN HIGHER EDUCATION, PROCEEDINGS OF THE 14TH INTERNATIONAL CONFERENCE EFFICIENCY AND RESPONSIBILITY IN EDUCATION 2017 (ERIE), Book Series: Efficiency and Responsibility in Education ....., Pages: 469-481, 14th International Conference on Efficiency and Responsibility in Education (ERIE), JUN 08-09, 2017, Prague, CZECH REPUBLIC, ISSN: 2336-744X, ISBN: 978-80-213-2762-7, Published: 2017;

308. Tutelea, L.N., Deaconu, S.I., Popa, G.N. FEM analysis of a single stator dual PM rotors axial synchronous machine, INTERNATIONAL CONFERENCE ON APPLIED SCIENCES (ICAS2016), Book Series: IOP Conference Series–Materials Science and Engineering, Volume: 163, Article Number: UNSP 012006, International Conference on Applied Sciences (ICAS), MAY 25-27, 2016, Hunedoara, ROMANIA, ISSN: 1757-8981, Published: 2017;
309. Urlan, S.D., Karancsi, O., Mitelea, I., Burca, M. MICROSTRUCTURE OF DISSIMILAR JOINTS BETWEEN DUPLEX STAINLESS STEEL AND LOW ALLOYED STEEL, METAL 2017: 26TH INTERNATIONAL CONFERENCE ON METALLURGY AND MATERIALS, Pages: 997-1002, 26th International Conference on Metallurgy and Materials (METAL), MAY 24-26, 2017, Brno, CZECH REPUBLIC, ISBN: 978-80-87294-79-6, Published: 2017;
310. Ursu, D., Tutelea, L.N., Ionel, D., Boldea, I. Optimal design of BLDC multi-phase reluctance machines (MRM) for variable speed drives, 2017 INTERNATIONAL CONFERENCE ON OPTIMIZATION OF ELECTRICAL AND ELECTRONIC EQUIPMENT (OPTIM) & 2017 INTL AEGEAN CONFERENCE ON ELECTRICAL MACHINES AND POWER ELECTRONICS (ACEMP), Pages: 483-488, International Conference on Optimization of Electrical and Electronic Equipment (OPTIM) / Intl Aegean Conference on Electrical Machines and Power Electronics (ACEMP), MAY 25-27, 2017, Brasov, ROMANIA, ISBN: 978-1-5090-4489-4, Published: 2017;
311. Vaida, D., Lelea, D. Municipal Solid Waste Incineration: Recovery or Disposal. Case Study of City Timisoara, Romania, 10TH INTERNATIONAL CONFERENCE INTERDISCIPLINARITY IN ENGINEERING, INTER-ENG 2016, Book Series: Procedia Engineering, Volume: 181, Pages: 378-384, 10th International Conference on Interdisciplinarity in Engineering (INTER-ENG), OCT 06-07, 2016, Tirgu Mures, ROMANIA, ISSN: 1877-7058, Published: 2017;
312. Vasilescu, M.D., Ionel, I. 3D printer FABLAB for students at POLITEHNICA University Timisoara, 2017 IEEE 17TH INTERNATIONAL CONFERENCE ON ADVANCED LEARNING TECHNOLOGIES (ICALT), Book Series: IEEE International Conference on Advanced Learning Technologies, Pages: 512-513, 17th IEEE International Conference on Advanced Learning Technologies (ICALT), JUL 03-07, 2017, Timisoara, ROMANIA, ISSN: 2161-3761, ISBN: 978-1-5386-3870-5, Published: 2017;
313. Vataman, A., Grecea, D. A Numerical Investigation for the Optimisation of the Seismic Response of Steel Eccentrically Braced Frames with Short Dissipative Elements, MODERN TECHNOLOGIES FOR THE 3RD MILLENNIUM, Pages: 291-296, 16th National Technical-Scientific Conference on Modern Technologies for the 3rd Millennium, MAR 23-24, 2017, Oradea, ROMANIA, ISBN: 978-88-87729-41-2, Published: 2017;
314. Vert, S., Andone, D. Zero-programming Augmented Reality Authoring Tools for Educators: Status and Recommendations, 2017 IEEE 17TH INTERNATIONAL CONFERENCE ON ADVANCED LEARNING TECHNOLOGIES (ICALT), Book Series: IEEE International Conference on Advanced Learning Technologies, Pages: 496-498, 17th IEEE International Conference on Advanced Learning Technologies (ICALT), JUL 03-07, 2017, Timisoara, ROMANIA, ISSN: 2161-3761, ISBN: 978-1-5386-3870-5, Published: 2017;
315. Vert, S., Vasiu, R. Augmented Reality Lenses for Smart City Data: The Case of Building Permits, RECENT ADVANCES IN INFORMATION SYSTEMS AND TECHNOLOGIES, VOL 1, Book Series: Advances in Intelligent Systems and Computing, Volume: 569, Pages: 521-527, World Conference on Information Systems and Technologies (WorldCIST), APR 11-13, 2017, Madeira, PORTUGAL, ISSN: 2194-5357, eISSN: 2194-5365, ISBN: 978-3-319-56535-4; 978-3-319-56534-7, Published: 2017;
316. Vilceanu, C.B., Herban, S., Musat, C. Time Structural Behaviour of Buildings Monitored by Topographic Technologies, MODERN TECHNOLOGIES FOR THE 3RD MILLENNIUM, Pages: 99-104, 16th National Technical-Scientific Conference on Modern Technologies for the 3rd Millennium, MAR 23-24, 2017, Oradea, ROMANIA, ISBN: 978-88-87729-41-2, Published: 2017;
317. Vilceanu, C.B., Grecea, C., Musat, C. Relevancy of Mathematical Support for Geophysics Determinations, PROCEEDINGS OF THE INTERNATIONAL CONFERENCE ON NUMERICAL ANALYSIS AND APPLIED MATHEMATICS 2016 (ICNAAM-2016), Book Series: AIP Conference Proceedings, Volume: 1863, Article Number: UNSP 430008-1, International Conference on Numerical Analysis and Applied Mathematics (ICNAAM), SEP 19-25, 2016, Rhodes, GREECE, ISSN: 0094-243X, ISBN: 978-0-7354-1538-6, Published: 2017;
318. Vinga, C., Cazacu, E., Frigura-Iliasa, F.M., Vatau, D. Educational Model for Diamagnetic Material Applications in Micro and Nano Levitation Devices, 2017 16TH INTERNATIONAL CONFERENCE ON INFORMATION TECHNOLOGY BASED HIGHER EDUCATION AND TRAINING (ITHET), Book Series: International Conference on Information Technology Based Higher Education and Training, 16th International Conference on Information Technology Based Higher Education and Training (ITHET), JUL 10-12, 2017, Ohrid, MACEDONIA, ISSN: 2380-1603, ISBN: 978-1-5386-3968-9, Published: 2017;

319. Visescu, M., Beilicci, E., Beilicci, R. Integrated Hydrographical Basin Management. Study Case - Crasna River Basin, WORLD MULTIDISCIPLINARY CIVIL ENGINEERING-ARCHITECTURE-URBAN PLANNING SYMPOSIUM – WMCAUS, Book Series: IOP Conference Series-Materials Science and Engineering, Volume: 245, Article Number: UNSP 032038, World Multidisciplinary Civil Engineering-Architecture-Urban Planning Symposium (WMCAUS), JUN 12-16, 2017, Prague, CZECH REPUBLIC, ISSN: 1757-8981, Published: 2017;
320. Vlazan, P., Sfirloaga, P., Poienar, M., Stoia, M. Structure and properties of nanocrystalline Bi<sup>3+</sup> doped KNbO<sub>3</sub> ceramics obtained by hydrothermal method, MATERIALS TODAY-PROCEEDINGS, Volume: 4, Issue: 7, Pages: 7018-7024, Part: 1, 13th International Conference on Nanosciences and Nanotechnologies (NN) / 9th International Symposium on Flexible Organic Electronics (ISFOE), JUL 04-07, 2016, Thessaloniki, GREECE, ISSN: 2214-7853, Published: 2017.



# BOOKS



## EVOLUTION OF BOOKS UNDER AFFILIATIONS OF PUT 2013 - 2017

A published book is indisputable evidence of research that has been performed, completed, and accepted by peers. Book is also an indicator of achievement of a certain academic standard. Besides communication of a finalised piece of research, the book is the basis for further opinions, views and critiques from fellow professionals and academics separated by time and distance. Most importantly, it represents the only permanent record of scientific work that has been completed.

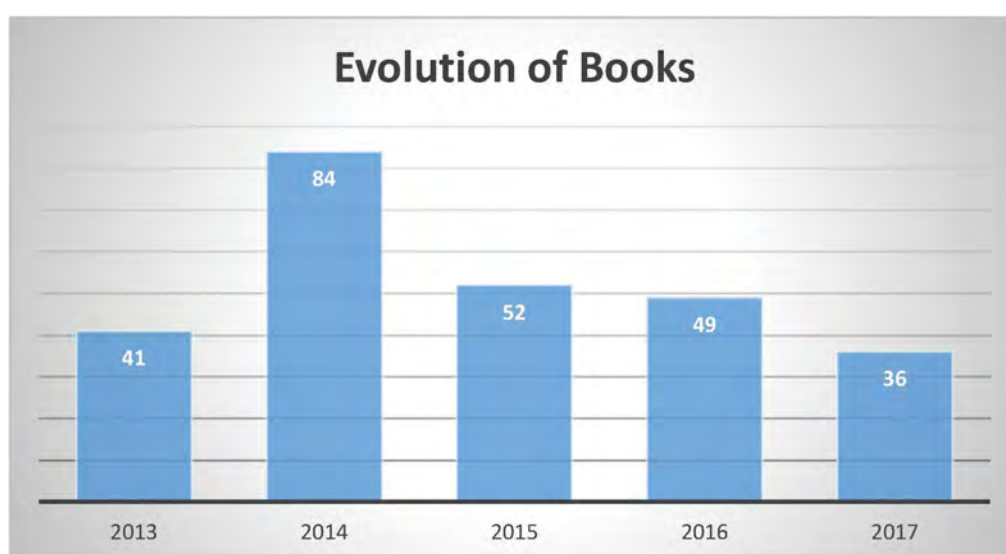

In this chapter we present the books written by our professors and researchers, published at Romanian publishers as well as at international prestigious publishers.





## *Books in highlight*



## DESIGN OF STEEL STRUCTURES FOR BUILDING IN SEISMIC AREAS: EUROCODE 8: DESIGN OF STRUCTURES FOR EARTHQUAKE RESISTANCE. PART 1: GENERAL DESIGN OF STEEL STRUCTURES FOR BUILDINGS

Raffaele LANDOLFO, Federico MAZZOLANI, Dan DUBINA,  
Luís Simões DA SILVA, Mario D'ANIELLO  
ECCS—European Convention for Constructional Steelwork,  
2017, 510 pages  
ISBN (ECCS): 978-92-9147-138-6  
ISBN (Ernst & Sohn): 978-3-433-03010-3

### Short description of the context

This volume elucidates the design criteria and principles for steel structures under seismic loads according to Eurocode 8-1. Worked Examples illustrate the application of the design rules. Two case studies serve as best-practice samples.

### Purpose and Motivation of the book

This book is developed with a constant reference to Eurocode 8 or EN 1998-1:2004; it follows the organization of that code and provides detailed explanations in support of its rather dry expression. Of course, there are many other seismic design codes, but it must be stressed that there is nowadays a strong common thinking on the principles and the application rules in seismic design so that this book is also a support for the understanding of other continents codes.

### Summary

**Chapter 1** explains the principles of seismic design and their evolution throughout time, in particular the meaning, goals and conditions set forward by capacity design of structures and their components, a fundamental aspect of seismic design.

**Chapter 2** explains the general aspects of seismic design: seismic actions, design parameters related to the shape of buildings, models for the analysis, safety verifications. Methods of analysis are explained in an exhaustive way: theoretical background, justifications of limits and factors introduced by the code, interest and drawbacks of each method, together with occasionally some tricks to facilitate model making and combination of load cases.

**Chapter 3** focuses on design provisions specific to steel structures: ductility classes, requirements on steel material, structural typologies and design conditions related to each of them; an original insight on design for reparability is also included.

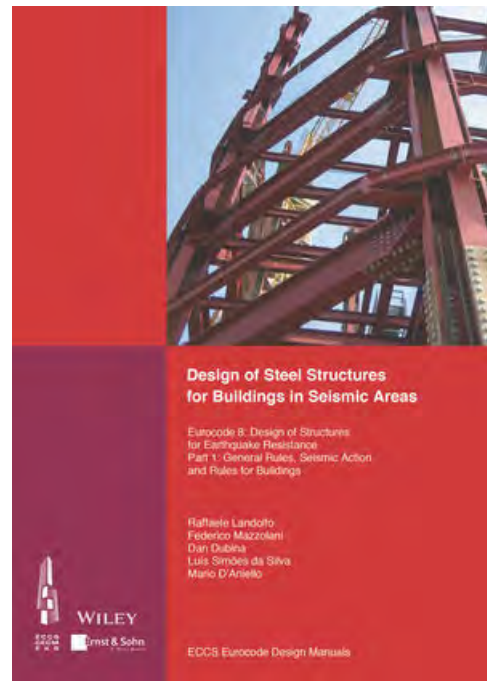

**Chapter 4** provides an overview about the best practice to implement the requirements and design rules for ductile details, particularly for connections in moment resisting frames (MRF), concentrically braced frames (CBF) and eccentrically braced frames (EBF), and for other structural components like diaphragms.

**Chapter 5** describes the guidance provided for design assisted by testing by EN 1990 and the specific rules for tests, a necessary tool for evaluating the performance characteristics of structural typologies and components in the plastic field and in cyclic/dynamic conditions.

**Chapter 6** illustrates and discusses the design steps and verifications required by EN 1998-1 for a multi-storey Moment Resisting Frame.

**Chapter 7 and 8** do the same respectively for buildings with CBF's and EBF's.

**Chapter 9** presents three very different examples of real buildings erected in high seismicity regions: one tall building, one industrial hall and one design using base isolation. These examples are complete in the sense that they show the total design, where seismic aspects are only one part of the problem. These examples are concrete, because they illustrate practical difficulties of the real world with materials, execution, positioning . . .

## MICROACTUATORS AND MICROMECHANISMS BOOK SERIES: MECHANISMS AND MACHINE SCIENCE, VOL.45

Lena ZENTNER, Burkhard CORVES, Brian JENSEN,  
Erwin-Christian LOVASZ

© Springer International Publishing AG, 2017, 261 pages

ISBN: 978-3-319-45386-6; 978-3-319-45387-3

DOI: 10.1007/978-3-319-45387-3

### Short description of the context

This volume contains twenty-two contributions from researchers from ten countries, represented at the 4th Conference on Microactuators and Micromechanisms, which was held in 2016 in Ilmenau, Germany. The aim of the conference was to provide a special opportunity for a know-how exchange and collaboration in various disciplines concerning systems pertaining to micro-technology. This Conference was organized under the patronage of IFToMM (International Federation for the Promotion of Mechanism and Machine Science).

### Purpose and Motivation of the book

This book brings together investigations which combine theoretical and experimental results related to such systems as capsule micromechanisms, active micro catheters, nanotube vascular stents, mechanisms for micromilling, different compliant mechanisms including grippers and compliant systems with actuators and sensors, microrobots based on vibrations, tactile sensors, tooth brackets, compliant valves, and space reflectors.

### Summary

1. Study on Polymer-Made 3DOF Spatial Parallel Manipulator
2. Miniaturization of Check Valves
3. A Biologically Inspired Sensor Mechanism for Amplification of Tactile Signals Based on Parametric Resonance
4. Towards the Development of Tactile Sensors for Determination of Static Friction Coefficient to Surfaces
5. Development and Investigation of Photoelastic Sensor for Torque Measurement
6. Flexural Body for a Wireless Force/Displacement Sensor
7. Capsule Micromechanism Driven by Impulse - Wireless Implementation
8. Development of Peristaltically Propelled Active Catheter Used in Radial Artery
9. Locomotion Principles for Microrobots Based on Vibrations
10. Exploration of Carbon-Filled Carbon Nanotube Vascular Stents

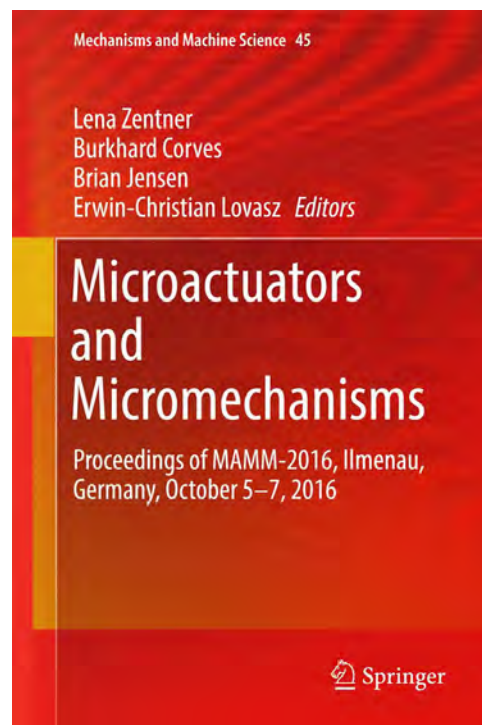

11. A Novel Gripper Based on a Compliant Multistable Tensegrity Mechanism
12. Selection of the Optimal Rigid-Body Counterpart Mechanism in the Compliant Mechanism Synthesis Procedure
13. Design and Experimental Characterization of a Flexure Hinge-Based Parallel Four-Bar Mechanism for Precision Guides
14. Dynamic Model of a Compliant 3PRS Parallel Mechanism for Micromilling
15. Dynamic Analysis of a Fatigue Test Bench for High Precision Flexure Hinges
16. Self-setting Locks for Petal Type Deployable Space Reflector
17. Monolithic and Statically Balanced Rotational Power Transmission Coupling for Parallel Axes
18. Investigation of the Novelty Brackets "Gold-S"
19. Dynamic Behavior of Active Lightweight Compliant Mechanisms with Integrated Piezoceramic Actuators by Under and Overcritical Periodic Excitation
20. Synthesis of Compliant Mechanisms with Defined Kinematics
21. A Concept of Adaptive Two Finger Gripper with Embedded Actuators
22. Implementation of Self Contact in Path Generating Compliant Mechanisms

## NEW ADVANCES IN MECHANISMS, MECHANICAL TRANSMISSIONS AND ROBOTICS BOOK SERIES: MECHANISMS AND MACHINE SCIENCE, VOL.46

Burkhard CORVES, Erwin-Christian LOVASZ, Mathias HÜSING,  
Inocentiu MANIU, Corina GRUESCU

© Springer International Publishing AG, 2017, 497 pages

ISBN: 978-3-319-45450-4; 978-3-319-45449-8

DOI: 10.1007/978-3-319-45450-4

### Short description of the context

This volume presents the proceedings of the Joint International Conference of the XII International Conference on Mechanisms and Mechanical Transmissions (MTM) and the XXIII International Conference on Robotics (Robotics '16), that was held in Aachen, Germany, October 26th-27th, 2016. .

### Purpose and Motivation of the book

It contains applications of mechanisms and transmissions in several modern technical fields such as mechatronics, biomechanics, machines, micromachines, robotics and apparatus. In connection with these fields, the work combines the theoretical results with experimental testing. The book presents reviewed papers developed by researchers specialized in mechanisms analysis and synthesis, dynamics of mechanisms and machines, mechanical transmissions, biomechanics, precision mechanics, mechatronics, micromechanisms and microactuators, computational and experimental methods, CAD in mechanism and machine design, mechanical design of robot architecture, parallel robots, mobile robots, micro and nano robots, sensors and actuators in robotics, intelligent control systems, biomedical engineering, teleoperation, haptics, and virtual reality.



### Summary

- MTM - Mechanisms - Analysis and Synthesis
- MTM - Dynamics of Mechanisms and Machines
- MTM - Mechanical Transmissions
- MTM - Micromechanisms and Microactuators
- MTM - Computational and Experimental Methods
- MTM - Terminology
  
- Robotics - Mechanical Design of Robot Architecture
- Robotics - Mobile Robots
- Robotics - Parallel Robots
- Robotics - Sensors and Actuators in Robotics
- Robotics - Robotic Control Systems
- Robotics - Biomedical Engineering
- Robotics - Teleoperation, Haptics, Virtual Reality
- Robotics - Compliant Structures
- Robotics - Robotic Applications



# Books List





1. Andea, P., Frigură – Ilasă, F.M., Olariu, A.F. Aparate și echipamente electrice, Editura Politehnica, Timișoara, 2017, ISBN 978-606-35-0189-0;
2. Argeșeanu, A., Lascu, C. Circuite numerice. Analiza. Sinteza. Modelare/simulare. Aplicații, Editura Politehnica, Timișoara, 2017, ISBN 978-606-554-750-6;
3. Arieșanu, C.O., Iosif, I.R. Linear algebra and geometry for electrical engineering, Editura Politehnica, Timișoara, 2017, ISBN 978-606-35-0172-2;
4. Baltă, H., Kovaci, M., Lucaciu, R. Teoria informației și a codării. Teste grilă, Editura Politehnica, Timișoara, 2017, ISBN 978-606-35-0119-7;
5. Bordeășu, I., Păcurar, C., Bordeășu, D. Hidraulică. Noțiuni teoretice și probleme de hidrostatică, Editura Politehnica, Timișoara, 2017, ISBN 978-606-35-0166-1;
6. Bosioc, A. Mecanica fluidelor și mașini hidraulice. Suport de curs și aplicații de calcul, Editura Politehnica, Timișoara, 2017, ISBN 978-606-35-0183-8;
7. Bucă, M., Cernicova-Bucă, M. Dicționarul general de expresii și locuțiuni ale limbii române, vol. 1-2, 564 p., Editura de Vest, Timișoara, 2017, ISBN 978-973-36-0626-0;
8. Ciurdariu, L. Matematici asistate de calculator, Editura Politehnica, Timișoara, 2017, ISBN 978-606-554-387-4;
9. Corves, B., Lovasz, E.C., Hüsing, M., Maniu, I., Gruescu, C. New Advances in Mechanisms, Mechanical Transmissions and Robotics, Book Series: Mechanisms and Machine Science, vol.46, Springer International Publishing AG, 2017, ISBN: 978-3-319-45450-4; 978-3-319-45449-8;
10. Costescu, C. Elemente de bază pentru proiectarea drumurilor, Editura Politehnica, Timișoara, 2017, ISBN 978-606-35-0105-0;
11. Crișan Vida, M., Chirilă, O.S., Gal Nădășan, N. Programare orientată pe obiecte în limbajul C++. Aplicații practice, Editura Politehnica, Timișoara, 2017, ISBN 978-606-554-749-0;
12. David, I., Stăniloiu, C., Ștefănescu, C. Hidraulik – Praxis orientierte Grundlagen und Anwendungen, Editura Orizonturi Universitare, Timișoara, 2017, ISBN 978-973-638-622-0;
13. Dumitrescu, C., Blidariu, C. Ecotectură, Editura Politehnica, Timișoara, 2017, ISBN 978-606-35-0142-5;
14. Dungan, L.I., Balogh, R.M. Vehicule feroviare cu motoare termice. Lucrări practice, Editura Politehnica, Timișoara, 2017, ISBN 978-606-35-0158-6;
15. Filipescu, H.E., Tehnici de modelare CAD în ingineria mecanică, Editura Politehnica, Timișoara, 2017, ISBN 978-606-35-0122-7;
16. Iagăr, A., Popa G.N., Diniș C.M. Calitatea energiei electrice – de la teorie la experimentări, Editura Politehnica, Timișoara, 2017, ISBN 978-606-35-0130-2;
17. Ionel, S. Romania in quotations/România în citate, Editura Politehnica, Timișoara, 2017, ISBN 978-606-35-0151-7;
18. Jianu, C. Analiza structurală a mecanismului bielă – furcă a turbinelor Kaplan, Editura Politehnica, Timișoara, 2017, ISBN 978-606-35-0128-9;

19. Jianu, C. Simulări numerice ale mecanismului de reglare la turbinele Kaplan, Editura Politehnica, Timișoara, 2017;
20. Jurcuț, V. La linia de 7... decenii, Editura Politehnica, Timișoara, 2017, ISBN 978-606-35-0160-9;
21. Kisilewicz, I. Conservarea creației. Recunoașterea materialelor și cercetarea, vol. I, 156 p., Editura Fundației „România de Măine”, București, 2017, ISBN: 978-606-20-0024-0;
22. Landolfo, R., Mazzolani, F., Dubina, D., da Silva, L.S., D’Aniello, M. Design of Steel Structures for Building in Seismic Areas: Eurocode 8: Design of Structures for Earthquake Resistance. Part 1: General Design of Steel Structures for Buildings, ECCS—European Convention for Constructional Steelwork, 2017, ISBN (ECCS): 978-92-9147-138-6, ISBN (Ernst & Sohn): 978-3-433-03010-3;
23. Lăzureanu, C. Curs de algebră liniară, Editura Politehnica, Timișoara, 2017, ISBN 978-606-35-0181-4;
24. Mansoor, K.R. Investigating semantic and syntactic equivalences in the translation process, Editura Politehnica, Timișoara, 2017, ISBN 978-606-35-0176-0;
25. Păunescu, D., ș.a. Culegere de probleme de matematică pentru examenul de admitere din anul 2019 la Universitatea Politehnica Timișoara, Editura Politehnica, Timișoara, 2017, ISBN 978-606-35-0184-5;
26. Păunescu, D., ș.a. Culegere de probleme pentru examenul de bacalaureat și admiterea din anul 2018 la Universitatea Politehnica Timișoara, Editura Politehnica, Timișoara, 2017, ISBN 978-606-554-725-4;
27. Pop, C. Aplicații și lucrări practice de statistică în inginerie. Pentru programele de studii de licență și master, Editura Politehnica, Timișoara, 2017, ISBN 978-606-35-0143-2;
28. Popa, D. Digital Telephony. Laboratory Applications, Editura Politehnica, Timișoara, 2017, ISBN 978-606-35-0144-9;
29. Popa, S. Utilaje în industria chimică organică, Editura Politehnica, Timișoara, 2017, ISBN 978-606-35-0185-2;
30. Saftencu, D., Pecican, A.H. Poliedre. Secțiuni plane. Desfășurate. Teme de lucru, Editura Politehnica, Timișoara, 2017, ISBN 978-606-35-0180-7;
31. Tănasă, C., Bosioc, A.I. Tehnici de control a curgerii cu rotație în difuzorul conic al turbinelor hidraulice, Editura Politehnica, Timișoara, 2017, ISBN 978-606-35-0182-1;
32. Tutelea, L.N., Muntean, N., Deaconu, S.I. Dual stator winding induction generator for wind and hydro applications, Editura Politehnica, Timișoara, 2017, ISBN 978-606-35-0111-1;
33. Țigan, G. Learning Calculus by Solved Problems, Editura Politehnica, Timișoara, 2017, ISBN 978-606-35-0163-0;
34. Vasilescu, M. Utilaje și instalații. Proiectare. Realizare. Reparare, Editura Politehnica, Timișoara, 2017, ISBN 978-606-35-0109-8;
35. Vilceanu, C.B. Sisteme Informatice Geografice. Concepte și aplicații, Editura Politehnica, Timișoara, 2017, ISBN 978-606-35-0125-8;
36. Zentner, L., Corves, B., Jensen, B., Lovasz, E.C. Microactuators and Micromechanisms, Book Series: Mechanisms and Machine Science, vol.45, Springer International Publishing AG, 2017, ISBN: 978-3-319-45386-6; 978-3-319-45387-3;

# Book Chapters List



1. Cernaianu, M.O., Gontean, A. Energy Harvesting and Energy Conversion Devices Using Thermoelectric Materials, RENEWABLE AND ALTERNATIVE ENERGY: CONCEPTS, METHODOLOGIES, TOOLS, AND APPLICATIONS, Pages: 1029-1080, ISBN: 978-1-5225-1672-9; 978-1-5225-1671-2, 2017;
2. Gheju, M. Decontamination of Hexavalent Chromium-Polluted Waters: Significance of Metallic Iron Technology, ENHANCING CLEANUP OF ENVIRONMENTAL POLLUTANTS, VOL 2: NON-BIOLOGICAL APPROACHES, Pages: 209-253, ISBN: 978-3-319-55423-5; 978-3-319-55422-8, 2017;
3. Lupa, L., Negrea, P., Popa, A. Use of Ionic Liquids in Solid-Liquid Separation Processes, PROGRESS AND DEVELOPMENTS IN IONIC LIQUIDS, Pages: 517-537, ISBN: 978-953-51-2902-8; 978-953-51-2901-1, 2017.







# Politehnica University of Timisoara



Piata Victoriei No. 2  
RO 300006, Timisoara  
Tel: +40 256 40 30 00  
Fax: +40 256 40 30 21  
Email: [rector@upt.ro](mailto:rector@upt.ro)  
[www.upt.ro](http://www.upt.ro)



EDITURA POLITEHNICA

ISSN 1841-2769