

Research  
Report 2023

**Annual  
Research  
Report**  
Politehnica  
University  
Timișoara  
2023



## Structure of the report

Introducing the Report .....	5
Research Centers .....	9
Renar Accredited Laboratories .....	17
Scientific Excellence Awards .....	21
National Research Projects .....	49
International Research Projects.....	83
Projects supported by private funds .....	115
Granted Patents.....	143
Doctor Honoris Causa .....	151
Habilitation Thesis .....	159
PhD Thesis.....	163
Scientific Conferences.....	171
Scientific Journals .....	183
ISI Papers in highlight.....	189
Books in highlight .....	227
Books List .....	233



# Introducing the Report



“It’s not the walls that make a school, but the spirit living inside.”  
King Ferdinand I, 1923

The needs for a modern society, in the context of a competitive global market, require highly skilled human resource development. In this context, the role of universities in the innovation process has increased continuously over time because the development of new products or technologies depends more and more on the findings of scientific research.

Established in 1920, shortly after the union of Romanian territories, in a European context marked by the redefinition of states and by the aftermath of World War I, the Polytechnic School in Timișoara – as it was originally called – was the answer to one of the requirements of the Romanian society of the time, namely the formation of engineers.

The mission of the Politehnica University Timisoara (UPT) is to offer nationally competitive and internationally recognized opportunities for Learning, Research, and Innovation at the highest levels of excellence. As a resource of knowledge for the public, the university builds partnerships with other educational institutions, community organizations, government agencies, and the private sector to fulfil the requirements for competencies of the societal environment through superior professional training for students and graduates.

The present Research Report of Politehnica University Timisoara gathers the main results obtained through the research activities carried out within the university in 2023, Politehnica being renowned as a remarkable actor on the stage of scientific research, both at national and international level. Our research activity is facilitated by the existence of thirty-two research centers specialized in fields that are capital for the sustainable development of any modern society. Each of these research centers brings together various prestigious researchers, whom, by their effort and vision, provide UPT with the incentives needed to contribute to the progress of our society.

Most of the research activity carried out by our institution is financed through external sources, obtained either from national and international calls for projects, or through agreements with private companies. This represents a confirmation of the superior quality of the research, but also of the prestige and professional deontology of the researchers affiliated to our institution. Politehnica’s reputation as an institution of advanced research is also emphasized by the patents obtained by its researchers, by the medals and prizes obtained in both national and international competitions, and by the collaborations with important research centers and institutes from Romania and from abroad.

Each year we select the most talented young researchers for our doctoral school, providing them with the opportunity to transform their knowledge and ideas into the innovations of tomorrow. Many of them take part in peer learning programs and consolidate in this way the relationship between our university and similar partner institutions. They strive for becoming doctors in science.

This report is divided into fifteen sections, each one presenting a specific component of the research activity performed within the institution.

The first section focuses on the research infrastructure, which comprises the thirty-two research centers hosted by the university. The order in which they are presented is given by the research fields. The research centers, respectively teams of researchers, on different themes, are highly important for our university since they manage to put into practice the scientific research strategy of the university successfully, within the framework of numerous grants and contracts won by competition. The research results are materialized in papers, patents and products, all bringing for the University prestige, as well as important funds.

# Research Report 2023

The second section of the Research Report presents Renar accredited laboratories of the Politehnica University Timisoara.

The third section of the Research Report is dedicated to the Scientific Excellence Awards. These prestigious awards celebrate those colleagues who have made a significant contribution in their field of research and continue to inspire future generations to get involved in science.

The fourth, fifth and sixth sections include the research projects implemented by the university. The fourth and fifth sections includes the projects supported by public funds, both national and international, while the sixth one includes the projects supported by private funds awarded by companies. For the purposes of this report, we have chosen the most relevant projects for our the most representative projects for our research strategy.

The innovative capacity of the Politehnica University Timisoara is supported by teachers and scientific researchers through patents invented, presented in the seventh section.

Politehnica University Timisoara recognizes scientific excellence by conferring the honorary degrees of Doctor Honoris Causa to distinguished researchers for their contribution to the development of UPT of continuous support, as shown in section eight of this Report.

Sections nine and ten include habilitation theses and Ph.D. theses held in 2023 in our University.

Section eleven presents an overview of the most relevant scientific conferences that brought together scholars and professionals from Romania and from abroad. The conferences hosted by our university encouraged the dialogue, facilitated the exchange of ideas, and offered a great opportunity for new collaborations.

The twelve section gathers the scientific journals that have been published by our institution. This category includes journals specialized in various fields, such as computer science, chemistry and environmental engineering, electronics and communications, economics and social sciences, electrical engineering, mathematics and physics, hydrotechnics, physical education and sport, modern languages, etc.

The dissemination of the research results and findings is an integral part of the research process and the career in academia. Sections thirteen and fourteen present the most relevant scientific researches that have been published in 2023. It comprises the results obtained by our researchers, namely the papers that obtained recognition from some of the most prestigious journals, from both Romania and abroad.

And finally the fifteen section comprise a collection of books written by our researchers, most of them published under Politehnica Publishing House.

Through research, we generate ideas, through ideas we generate innovation and through innovation we contribute to the improvement of the quality of life; this is why research is our priority.



# RESEARCH CENTERS



## Center for Innovation and Technology Transfer Politehnica 2020 (CITT) of the Politehnica University Timisoara

In the 11<sup>th</sup> of November 2020, the **Center for Innovation and Technology Transfer (CITT) Politehnica 2020** received the provisional authorization from the Ministry of Research, Innovation and Digitalization, for a 12 month period, followed by a **permanent accreditation order** signed on the 19<sup>th</sup> of January 2022 in the fields of:

- √ *Eco-nano-technologies and advanced materials*
- √ *Information and communication technologies*
- √ *Energy, environment and climate change*



CITT  
POLITEHNICA 2020

The **mission** of CITT is the general stimulation of the collaboration activity between the Research Centers within the Politehnica University Timisoara and the economic and industrial environment, by supporting and encouraging the technological transfer, in order to introduce in the economic circuit the research results transformed into products, processes and new or improved services. CITT mediates the additional steps that separate laboratory knowledge from industrial technology.

The **vision** of the CITT is in line with the strategic policy of the European Union for economic growth for the next ten years, with efforts to gradually align with recent guidelines of EU policy dictated by the need to increase capacity and competitiveness of education and research – development – innovation presented in the NDP National Development Plan 2007–2013 and their compatibility with similar systems in the European Union.

The general **objectives** of the CITT are:

- a) Increasing the visibility of the research-innovation activity within the Politehnica University Timisoara regionally, nationally and internationally;
- b) Consultation of the academic community, through the representatives of the research centers, for the implementation of the mission assumed by the Strategic Plan;
- c) Training and development of human resources involved in the realization of projects;
- d) Initiating, promoting and advising inter- and multidisciplinary collaboration for the realization of projects;
- e) Supporting the achievement of the performance indicators of the Politehnica University Timisoara for the internal self-evaluation of the quality and the promotion of the quality in research;
- f) Modernization and efficiency of the material base necessary for the development of scientific research in the university;

- g) Orienting the research of the Politehnica University Timisoara towards the needs of the society on medium and long term and promoting the industrial doctorates;
- h) Achieving an efficient management of the research – development – innovation activity;
- i) Strengthening the dimension of national and international cooperation;
- j) Creating a climate of trust and scientific cooperation between UPT teachers, based on decision-making transparency;
- k) Periodic evaluation of the results of scientific research and research – development – innovation centers;
- l) Efficient management of technology transfer results through continuous updating of data, operation of the database and conducting statistical studies on activities;

The **role** of CITT is materialized through:

- a) Negotiating and drawing up research contracts, service contracts or partnership agreements with industrial partners;
- b) Supporting inventors to prove the concept and pre-industrial validation. CITT will also manage the protection of intellectual property generated by the institution. This includes identifying sources of funding, both internal and external, for the registration of applications for intellectual property protection (such as patents, trademarks or copyrights);
- c) Negotiation and preparation of license agreements and transfer of intellectual property to industry, with or without the support of specialized external legal advisers;
- d) CITT will encourage and support the creation of new companies.

CITT has the following **attributions**:

- a) Promotes the activity of innovation and technological transfer;
- b) Contributes to the implementation of the results of scientific research and advanced technologies;
- c) Ensures the access of SMEs to the technological services and RDI infrastructure of the Politehnica University Timișoara;
- d) Provides assistance for technology acquisitions (domestic or import);
- e) Ensures the realization and administration of product packages (CDI-production transfer documents);
- f) Ensures the efficient transfer of the results of the RDI teams to the production departments of the companies;
- g) Ensures the participation in competitions for RDI projects financed by the Romanian Government through the Ministry of National Education and in the projects financed by the EU;
- h) Elaborates statistical or feasibility studies for the activities carried out.

## Contact

ICER building on 138 Gavril Muzicescu Street 300501, Timișoara, România

Director, Assoc. Prof. Dr. Eng. Vlad MIHAESCU

Mail: [citt@upt.ro](mailto:citt@upt.ro), [vlad.mihaescu@upt.ro](mailto:vlad.mihaescu@upt.ro)

<https://www.facebook.com/CITT.UPT/>

Phone: (+40)256 403 450

## CITT in 2023

- **9 contracts with companies** were completed
- The project **Increasing the competitiveness of UPT by establishing the Center for Innovation and Technology Transfer Politehnica 2020** has been completed, V/TM/2020/1/1.1 .A/2/1467/27.10.2020, financed by the West Regional Development Agency within the Regional Operational Program 2014 –2020.

On August 30<sup>th</sup>, CITT was certified for the following fields of activities:

- Scientific and technological assistance and information;
- Coordination of innovation, dissemination, transfer and capitalization of research results which was implemented and maintains a quality management system which fulfils the requirements of the standard **SR EN ISO 9001:2015**.





## Research Institute for Renewable Energy

Director: Prof. Dr. Eng. Viorel UNGUREANU

Contact: [viorel.ungureanu@upt.ro](mailto:viorel.ungureanu@upt.ro), <https://www.icer.ro>, <https://eertis.eu>



## Research Center for Smart Energy Conversion and Storage

Director: Prof. Dr. Eng. Nicolae MUNTEAN

Contact: [nicolae.muntean@upt.ro](mailto:nicolae.muntean@upt.ro),  
<https://iee.upt.ro/web/ro/pdf/centru-de-cercetare-energy-conversion-and-storage-control-research-center>, <https://eertis.eu>



## "Ștefan Nădășan" Research Laboratory for Strength, Integrity and Durability of Materials, Structures and Conductors

Director: Prof. Dr. Eng. Liviu MARȘAVINA

Contact: [liviu.marsavina@upt.ro](mailto:liviu.marsavina@upt.ro), <https://eertis.eu>



## Research Center for Materials Mechanics and Structural Safety

Director: Acad. Prof. Dr. Eng. Dan DUBINĂ

Contact: [dan.dubina@upt.ro](mailto:dan.dubina@upt.ro), <https://www.ct.upt.ro/centre/cemsig/index.htm>



## Research Center for the Processing and Characterization of Advanced Materials

Director: Assoc. Prof. Dr. Eng. Bogdan RADU

Contact: [bogdan.radu@upt.ro](mailto:bogdan.radu@upt.ro), <https://sites.google.com/view/ccpcma/home>,  
<https://eertis.eu>

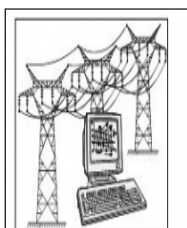

## Research Center for Power Systems Analysis and Optimization

Director: Assoc. Prof. Dr. Eng. Constantin BARBULESCU

Contact: [constantin.barbulescu@upt.ro](mailto:constantin.barbulescu@upt.ro), <https://iee.upt.ro/web/ro/departamente/electroenergetica/pdf/analiza-si-optimizarea-regimurilor-sistemelor-electroenergetice>, <https://eertis.eu>



## Research Center for Computers and Information Technology

Director: Prof. Dr. Eng. Mihai Victor MICEA

Contact: [mihai.micea@cs.upt.ro](mailto:mihai.micea@cs.upt.ro), <https://cs.upt.ro/ro/research>, <https://eertis.eu>



## Research Center for Organic, Macromolecular and Natural Compounds Chemistry and Engineering

Director: Prof. Dr. Eng. Daniel HĂDĂRUGĂ

Contact: [daniel.hadaruga@upt.ro](mailto:daniel.hadaruga@upt.ro), <https://www.chim.upt.ro/ro/cercetare/centre-cercetare/centru-de-cercetare-in-chimia-si-ingineria-compusilor-organici-macromoleculari-si-naturali>



## Competence Center for Plastics Processing

Director: Assoc. Prof. Dr. Eng. Aurel TULCAN

Contact: [aurel.tulcan@upt.ro](mailto:aurel.tulcan@upt.ro)



## Research Center for Hydrotechnics and Environmental Protection

Director: Prof. Dr. Eng. Constantin FLORESCU

Contact: [constantin.florescu@upt.ro](mailto:constantin.florescu@upt.ro), <https://www.ct.upt.ro/centre/cchpm/index.htm>



## Research Center for Infrastructure for Civil Engineering and Transport

Director: Prof. Dr. Eng. Liviu Adrian CIUTINĂ

Contact: [adrian.ciutina@upt.ro](mailto:adrian.ciutina@upt.ro), <https://www.ct.upt.ro/centre/ict>



## Research Center for Automatic Systems Engineering

Director: Prof. Dr. Eng. Radu-Emil PRECUP

Contact: [radu.precup@upt.ro](mailto:radu.precup@upt.ro), <https://www.aut.upt.ro/centru-cercetare>, <https://eertis.eu>



## Research Center for Complex Fluid Systems Engineering

Director: Prof. Dr. Eng. Romeo SUSAN-RESIGA

Contact: [romeo.resiga@upt.ro](mailto:romeo.resiga@upt.ro), <https://eertis.eu>



## Research Center for Medical Engineering

Director: Prof. Dr. Eng. Liviu MARȘAVINA

Contact: [liviu.marsavina@upt.ro](mailto:liviu.marsavina@upt.ro), <https://ccim.upt.ro>



## Research Center for Integrated Engineering

Director: Prof. Dr. Eng. George DRĂGHICI

Contact: [george.draghici@upt.ro](mailto:george.draghici@upt.ro), <http://imf.upt.ro/CCI/index.html>, <https://eertis.eu>



## Research Center for Engineering and Management

Director: Assoc. Prof. Dr. Larisa Victoria IVAȘCU

Contact: [larisa.ivascu@upt.ro](mailto:larisa.ivascu@upt.ro), <http://www.mpt.upt.ro/eng/research/research-center.html>



## Research Center for Building Services

Director: Lecturer Dr. Eng. Călin SEBARCHIEVICI

Contact: [calin.sebarchievici@upt.ro](mailto:calin.sebarchievici@upt.ro), <https://www.ct.upt.ro/centre/ccic>



## Research Center for Thermal Machines and Equipment, Transportation and Environmental Pollution Control

Director: Prof. Dr. Eng. Ioana IONEL

Contact: [ioana.ionel@upt.ro](mailto:ioana.ionel@upt.ro), <http://mettcp.mec.upt.ro>, <https://eertis.eu>



## Research Center for Inorganic Materials and Alternative Energy

Director: Prof. Dr. Eng. Robert IANOS

Contact: [robert.ianos@upt.ro](mailto:robert.ianos@upt.ro), <http://www.chim.upt.ro/ro/cercetare/centre-cercetare/centru-de-cercetare-pentru-materiale-anorganice-si-energii-alternative>



### Research Center for Materials and Industrial Technologies

Director: Prof. Dr. Eng. Teodor HEPUȚ

Contact: [teodor.heput@upt.ro](mailto:teodor.heput@upt.ro), <http://www.fih.upt.ro/ccmti/index.php>



### Research Center for Mechatronics and Robotics

Director: Prof. Dr. Eng. Inocențiu MANIU

Contact: [inocentiu.maniu@upt.ro](mailto:inocentiu.maniu@upt.ro), <https://mctr.mec.upt.ro/activitate-de-cercetare>



### Research Center for Advanced Study Methods for Physical Phenomena

Director: Prof. Dr. Eng. Nicolina Rodica POP

Contact: [nicolina.pop@upt.ro](mailto:nicolina.pop@upt.ro), <https://iee.upt.ro/web/ro/pdf/centru-de-cercetare-metode-avansate-de-studiu-fenomenelor-fizice>



### Research Center for Multimedia

Director: Prof. Dr. Eng. Radu VASIU

Contact: [radu.vasiu@upt.ro](mailto:radu.vasiu@upt.ro), [https://www.cm.upt.ro/ro\\_ro](https://www.cm.upt.ro/ro_ro)



### Research Center for Urban Planning and Architecture

Director: Assoc. Prof. Dr. Eng. Ileana KISILEWICZ

Contact: [ileana.kisilewicz@upt.ro](mailto:ileana.kisilewicz@upt.ro), <https://sites.google.com/view/ccua/ro>



### Research Center for Intelligent Signal Processing

Director: Prof. Dr. Eng. Alexandu ISAR

Contact: [alexandru.isar@upt.ro](mailto:alexandru.isar@upt.ro), <https://shannon.etc.upt.ro>



### Research Center for the Rehabilitation of Buildings

Director: Prof. Dr. Eng. Tamás NAGY GYÖRGY

Contact: [tamas.nagy-gyorgy@upt.ro](mailto:tamas.nagy-gyorgy@upt.ro), <https://www.ct.upt.ro/centre/reco>



### Research Center for Intelligent Electronic Systems

Director: Prof. Dr. Eng. Cătălin CĂLEANU

Contact: [catalin.caleanu@upt.ro](mailto:catalin.caleanu@upt.ro), <https://ccsei.upt.ro>, <https://eertis.eu>



### Research Center for Environmental Science and Engineering

Director: Prof. Dr. Eng. Florica MANEA

Contact: [florica.manea@upt.ro](mailto:florica.manea@upt.ro), <http://www.chim.upt.ro/ro/cercetare/centre-cercetare/centru-de-cercetare-in-stiinta-si-ingineria-mediului>, <https://eertis.eu>



### Smart Materials and Structures Laboratory

Director: Prof. Dr. Eng. Corneliu-Marius CRĂCIUNESCU

Contact: [corneliu.craciunescu@upt.ro](mailto:corneliu.craciunescu@upt.ro)



## **Center for Advanced Translation Studies**

Director: Prof. Dr. Eng. Daniel Codruț DEJICA-CARȚIȘ

Contact: [daniel.dejica@upt.ro](mailto:daniel.dejica@upt.ro), <https://sc.upt.ro/ro/cercetare/poli>



## **Center of Interdisciplinary Research in Communication and Sustainable Development**

Director: Prof. Dr. Eng. Vasile GHERHEȘ

Contact: [vasile.gherhes@upt.ro](mailto:vasile.gherhes@upt.ro), <https://sc.upt.ro/ro/cercetare/policom>



## RENAR ACCREDITED LABORATORIES



## RENAR accredited Laboratories of the Politehnica University Timisoara

### Laboratory for Fuel Analyses, Ecological Investigations and Pollutant Dispersion

**Head of laboratory:** Prof. Dr. Eng. Ioana IONEL

Contact: [ioana.ionel@upt.ro](mailto:ioana.ionel@upt.ro),

[http://www.mediu.ro/pdf/ANEXA\\_1\\_2021.pdf](http://www.mediu.ro/pdf/ANEXA_1_2021.pdf), <http://mettcp.mec.upt.ro/laboratoare.html>

### Laboratory of Acoustic and Vibration

**Head of laboratory:** Prof. Dr. Eng. Nicolae HERIȘANU

Contact: [nicolae.herisanu@upt.ro](mailto:nicolae.herisanu@upt.ro),

[https://www.renar.ro/index.php/oec/get\\_oec\\_details/43467](https://www.renar.ro/index.php/oec/get_oec_details/43467)



# SCIENTIFIC EXCELLENCE AWARDS



## A team of teachers and researchers from UPT, led by Prof. Radu-Emil PRECUP, awarded at the Romanian Research Gala – the 2024 edition

- The **Romanian Research Gala**, initiated by the Romanian Government in 2023 for the symbolic recognition: of performance in the field of research, became this year a competition with prizes, with a total budget of 3.3 million lei for the declared winners in 11 categories, brings a new recognition to a team of teachers and researchers from UPT.
- The team led by **Prof. Radu-Emil PRECUP**, corresponding member of the Romanian Academy and director of the Council for Doctoral Studies of UPT, composed of Assoc. Prof. Dr. Eng. **Claudia-Adina BOJAN-DRAGOȘ**, Assoc. Prof. Dr. Eng. **Adriana-Nicoleta ALBU**, Lecturer Dr. Eng. **Raul-Cristian ROMAN**, Lecturer Dr. Eng. **Alexandra-Iulia SZEDLAK-STÎNEAN**, Assist. Prof. Dr. Eng. **Elena-Lorena HEDREA** and PhD M.Sc. Eng. **Iuliu Alexandru ZAMFIRACHE**, was awarded, at the Romanian Research Gala 2024, in the Engineering Sciences category, the “Henri Coandă” prize, for pioneering research, innovative approaches and dedication to real-world applications with lasting impact in various fields.
- The team has addressed in the last five years aspects of theoretical and applied research in various subfields of automation: **low complexity fuzzy controllers**, **data-driven controller tuning techniques**, **machine learning techniques in control systems**, ensuring very good performance guaranteed by the developed systems, **observers for mechatronic systems**, **tensor product-based techniques** and **artificial intelligence in mathematical modelling**, prediction, control and decision-making in various fields including the medical one.

The results of the team, made up of prestigious researchers from the Process Management Group of UPT, were appreciated in 2019-2023 by:

- Outstanding scientometric indicators of the authors, expressed by **Hirsch indices** and **citation numbers** of extremely high values for the field in which the authors work and publish,
- Their nomination as **members of editorial boards of prestigious journals** and **programme committees of prestigious conferences**,
- Outstanding results achieved in contract research activity in the field, reflected in **substantial contracts obtained through competition**,
- **12 papers published in prestigious journals** are recognized by Web of Science as **Highly Cited Papers**,

- **5 papers** published in prestigious journals are recognized by Web of Science as **Hot Papers**,
- **Two “Tudor Tănăsescu” Awards of the Romanian Academy**,
- **Two Doctor Honoris Causa degrees** received by the team leader from universities abroad,
- The consistent placement of **two team members in the World’s Top 2% Scientists List**, according to studies conducted by Stanford University based on **Scopus results**,
- Inclusion of the team leader in the **Research.com Ranking of Top Scientists in Electronics and Electrical Engineering** in position 1131 of the world ranking and **first position in Romania**.

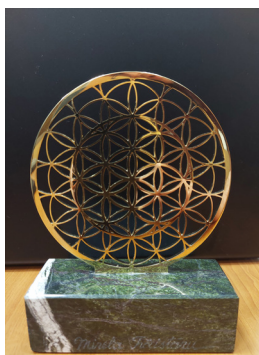

# Research Report 2023

Politehnica University Timisoara, in the [Research.com](#) Ranking of the best universities in 2022. Four professors, among the most important scientists in the world: Radu-Emil PRECUP, Ion BOLDEA, Ștefan PREITL and Liviu MARȘAVINA

- [Research.com](#), one of the most important portals dedicated to researchers / scientists in universities, released the ranking of the best universities in 2022, which include for the first time higher education institutions in Romania.

- The main criterion of the ranking was the sum of the H index values of all leading scientists associated with a particular university.

- According to the ranking, **the Politehnica University Timișoara ranks 4<sup>th</sup> in Romania and 1900<sup>th</sup> in the world, and the field of Electronics and Electrical Engineering occupies the 1<sup>st</sup> place in the country and the 291<sup>st</sup> in the world.**

- A leading scientist is a researcher with a **D index (H index for the subject of study)** higher than a certain threshold (in most cases 30 or 40) for their areas of study.

- [Research.com](#) also made a ranking of top scientists, with the highest H-index, the Politehnica University Timisoara being represented by four outstanding professors: **Radu-Emil PRECUP (H-index 58), Ion BOLDEA (H-index 50), Ștefan PREITL (H-index 38) and Liviu MARȘAVINA (H-index 33).**

- The ranking process involved a detailed examination of the profiles of 166,880 researchers from [Google Scholar](#) and [Microsoft Academic Graph](#), from over 2,814 institutions.

- The performance is all the more significant as the **total number of academic staff from the Politehnica University Timisoara is much lower than the number of academic staff from the universities ranked before it.**





## Romanian Academy Award 2021 – „Anghel Saligny” award – for the group of published papers: „The seismic behavior of reinforced concrete and hybrid/composite shear walls – Theoretical and experimental approaches”; Common authors: Daniel DAN and Valeriu - Augustin STOIAN

- The Romanian Academy offered on 7 December 2023, the awards for the most valuable scientific and artistic creations achieved in 2021.
- The „Anghel Saligny” Award for Technical Sciences was awarded for the group of published papers entitled, **The seismic behavior of reinforced concrete and hybrid/composite shear walls – Theoretical and experimental approaches**.
- The papers included in the group are published in the most valuable journals in Civil engineering field, Structures Q2 and Engineering Structures Q1.
- The common authors of the group of two papers are **Daniel Dan** and **Valeriu-Augustin Stoian**, professors at the Faculty of Civil Engineering at UPT.



- The awarded papers present the main results of a theoretical and experimental study that investigated the seismic behavior of hybrid/composite steel-concrete coupled walls with regular openings and the seismic performance of precast reinforced concrete wall panels with different openings.
- The main contributions refer to the mode of behavior, the critical regions, the maximum lateral load and the displacement capacity at the end stage, the dissipation capacity and ductility, the influences of the openings on the seismic performance of the shear wall and the precision of the theoretical estimations.



## “Tudor Tănăsescu” prize of Romanian Academy awarded to Assist. Prof. Dr. Eng. Elena-Lorena HEDREA for a group of three papers generically grouped in “Tensor product-based model transformation used for systems modeling and controller tuning”

- Assist. Prof. Dr. Eng. Elena-Lorena HEDREA has been awarded the “Tudor Tănăsescu Award” prize, given by the Romanian Academy for a group of three papers generically grouped in “Tensor product-based model transformation used for systems modeling and controller tuning”.
- The prize was officially awarded during the ceremony “Romanian Academy Awards for the year 2021” as part of the General Assembly of the Romanian Academy held on 07.12.2023 at 10:00 in the Aula of the Romanian Academy, [https://acad.ro/institutia/comunicate/2023/71\\_83\\_PremiileAR.html](https://acad.ro/institutia/comunicate/2023/71_83_PremiileAR.html)



- The Romanian Academy is a cultural forum founded in Bucharest, Romania, in 1866. It covers the scientific, artistic, and literary domains. The academy has 181 acting members who are elected for life.
- According to its bylaws, the academy's main goals are the cultivation of Romanian language and Romanian literature, the study of the national history of Romania and research into major scientific domains.
- Some of the academy's fundamental projects are the Romanian language dictionary, the dictionary of Romanian literature, and the treatise on the history of the Romanian people.
- Elena-Lorena HEDREA published in 2021, as first author, the following three papers in the field of **tensor product-based model transformation technique for modeling and control**:



- 1). E.-L. Hedrea, R.-E. Precup, E. M. Petriu, C.-A. Bojan-Drăgăș and C. Hedrea, Tensor product-based model transformation approach to cart position modeling and control in pendulum-cart systems, Asian Journal of Control, vol. 23, no. 3, pp. 1238-1248, 2021.
  - 2). E.-L. Hedrea, R.-E. Precup, R.-C. Roman and E. M. Petriu, Tensor product-based model transformation approach to tower crane systems modeling, Asian Journal of Control, vol. 23, no. 3, pp. 1313-1323, 2021.
  - 3). E.-L. Hedrea, R.-E. Precup, R.-C. Roman, E. M. Petriu, C.-A. Bojan-Drăgăș and C. Hedrea, Tensor Product-Based Model Transformation Technique Applied to Servo Systems Modeling, in Proc. 30<sup>th</sup> IEEE International Symposium on Industrial Electronics (ISIE), Kyoto, Japan, pp. 1-6, 2021.
- These papers have proposed a set of new contributions in the field, which are important because they ensure autonomy and adaptability to automatic control systems and they contribute to the **performance improvement of control systems designed for linear parameter-varying systems**.

## Professor Corneliu Ioan BOB, from the Politehnica University Timisoara, received the title of Doctor Honoris Causa of the University of Oradea

• Emeritus Professor Corneliu BOB, professor of the Politehnica University Timisoara, a renowned specialist in the field of Civil engineering in Romania, received the highest academic distinction, that of **Doctor Honoris Causa, from the University of Oradea.**

• Dean of the Faculty of Constructions, Cadastre and Architecture, Prof. Dr. Eng. Marcela Prada, listed the arguments that support the awarding of the high academic distinction to Professor Corneliu BOB. „He is one of the most important specialists in constructions education in Romania, which is shown by his entire activity in the field of Civil Engineering”.

• Corneliu BOB is an **Emeritus Professor of the Politehnica University Timisoara**, with an academic of 62 years, and for 17 years he has been working as an associate professor at the Faculty of Civil Engineering, Cadastre and Architecture (FCCA) from Oradea.

• **Emeritus Professor Corneliu Bob** was vice-dean of the Faculty of Civil Engineering (1978-1984), has two books published by international publishers, 28 books published in the country, he is the author of 11 specialized treatises, has published over 300 scientific papers, was cited in the country and abroad, is the holder of eight patents, has coordinated hundreds of technical certifications and is a coordinator or participant in 16 research grants.



• In parallel with his teaching, he also carried out an intense design and verification activity, having 185 designed projects and over 75 technical certifications. Between 1996 and 2004 he was **director at INCERC – Timișoara Branch.**

• He won the Aurel Vlaicu Prize of the Romanian Academy in 1981 for the book „New types of special concrete” and was declared „**highlighted associate professor**” in 1988.

• In recognition of his prolific activity, he was elected a member of IABSE (International Association for Bridge and Structural Engineering) in the Standing Committee and in Commission 8;

• **A member of E-Core-ECCREDI (European Council for Constructions Research);**

• **A member of the Commission „Science of materials” of the Romanian Academy – secretary of the Timisoara branch;**

• **A member of the editorial team of the SED magazine (Structural Engineering Documents), edited by IABSE (Zurich).**

## Diploma of Academic Merit of the Romanian Academy, awarded to the Romanian Journal of Information Science and Technology (ROMJIST) for the leading position in the Clarivate evaluation and the first place among the journals in Romania, from the point of view of the impact factor, Editor-in-Chief: Prof. Radu-Emil PRECUP

- The Romanian Journal of Information Science and Technology (ROMJIST), <https://www.romjist.ro/>, ISSN: 1453-8245, is a scientific publication of the Romanian Academy. It is edited by the Information Science and Technology Section, [https://acad.ro/institutia/sectia\\_14.html](https://acad.ro/institutia/sectia_14.html), of the Romanian Academy, [https://acad.ro/academia\\_romana/](https://acad.ro/academia_romana/).
- Almost all the members of the Section are included in the Editorial Board of ROMJIST. The printed version is published by the Publishing House of the Romanian Academy (Editura Academiei Române - RO, <http://www.ear.ro/>). The online version of ROMJIST is sponsored by the National Institute for Research and Development in Microtechnologies (IMT-Bucharest), <https://www.imt.ro/>.
- ROMJIST is indexed in Clarivate Analytics Web of Science (formerly ISI Web of Knowledge). According to the 2022 Journal Citation Reports (JCR) released by Clarivate Analytics in 2023, the impact factor of ROMJIST is 3.5, which places **ROMJIST in the first place among the journals in Romania, from the point of view of the impact factor**, <https://uefiscdi.gov.ro/resource-866594-rev.rom.scie.ssci.ahci.28.06.2023.pdf>.
- ROMJIST is ranked in the Q2 quartile in three ISI categories: Computer Science, Theory & Methods; Instruments & Instrumentation; Physics, Applied.
- As of January 2022, the editorial staff of ROMJIST consists of:  
Editor-in-Chief: Prof. **Radu-Emil PRECUP**, corresponding member of the Romanian Academy, Politehnica University Timisoara,  
Honorary Co-Editors-in-Chief: Acad. Horia-Nicolai Teodorescu, Institute of Computer Science, Romanian Academy, and Prof. Gheorghe Ștefan, corresponding member of the Romanian Academy, National University of Science and Technology Politehnica Bucharest (UNSTPB),  
Editorial Secretary: Eng. Adriana Apostol (UNSTPB), and Technical Editor of the online version: Assoc. Prof. Lucian-Petru Milea (UNSTPB), and Acad. Florin Gheorghe Filip, President of the Information Science and Technology Section of the Romanian Academy.
- The diploma was officially awarded to Prof. **Radu-Emil PRECUP** during the ceremony “**Romanian Academy Awards for the year 2021**”, within the framework of the General Assembly of the Romanian Academy, held on December 7, 2023 at 10:00 in the Aula of the Romanian Academy, [https://acad.ro/institutia/comunicate/2023/71\\_83\\_PremiileAR.html](https://acad.ro/institutia/comunicate/2023/71_83_PremiileAR.html).



## Prof. Emeritus Dr. Eng. Ioan SÂRBU - International prize “Best paper award” for the book “Advances in Building Services Engineering: Studies, researches and applications”

• A new international recognition of the value of the teaching staff, but also of the research carried out in the Politehnica University Timisoara comes precisely from India, where the professor emeritus **Ioan Sârbu** was awarded the international prize “**Best paper award**” by the scientific organization **ScienceFather**, at the 7<sup>th</sup> edition of the **International Research Excellence Awards**, which appreciate his exemplary work and research results, included in the book “**Advances in Building Services Engineering: Studies, researches and applications**” (<http://dx.doi.org/10.1007/978-3-030-64781-0>).

• The book, written in English and published in 2021 in both print and electronic format by the prestigious Springer, extends over 921 pages (11 chapters) and provides a comprehensive, systematic overview of original theoretical, experimental, and numerical studies (cited in about 2000 papers around the world) bringing together multiple strands of research in building services engineering domain with various subjects, guided by two important features such as energy savings and reduction of the pollutant emissions especially in recent decades.

• The publication of such a book is a novelty in the literature. It is unique with respect to its complex contents, the experimental case studies at lab scale, numerical examples and text presentation style.

• This Scopus indexed volume supports the dissemination of Romanian research results worldwide and the affirmation of the development of knowledge in the world, and **ScienceFather’s Merit-based Awards Platform** supports excellence in various fields in science and technology, candidates being evaluated according to of latest publications, research quality, novelty, previous achievements, research excellence and outstanding academic achievements.

• It should be noted that prof. emeritus Ioan Sârbu is the author of another 12 books/book chapters published abroad, one of which published by the Elsevier in 2017 was awarded by the Romanian Academy with the “**Henri Coandă**” award for Technical Sciences in 2019.

• All these honorable contributions and achievements in innovative research have brought him the recognition and respect of the academic society in our country and internationally.

• **Prof. Univ. Emeritus Dr. Eng. Ioan Sârbu**, currently doctoral supervisor at the Politehnica University Timisoara, within the Department of Civil and Building Services Engineering, graduated from the Faculty of Construction at the “Traian Vuia” Polytechnic Institute in Timisoara in 1975, who also obtained a doctorate in Civil Engineering in 1993 and in addition, he was designated a European engineer by the European Federation of National Engineering Associations in Brussels in 2001, he is a noted expert in integrating thermal applications, optimization of urban water and heat distribution systems, computer utilise, implementation of renewable energy sources and integrating wastewater treatment into the design.



• He performed outstanding scientific contributions in the development of design techniques for looped water and heat supply systems and in investigating the performance of conventional ground-coupled and hybrid heat pump systems in cooperation with photovoltaic-thermal panels.

• His scientific concerns did not stop after his retirement, being active with PhD students and younger university colleagues in the department, in addressing topics related to the optimization and modernization of building services systems, as well as the implementation of renewable energy sources within these systems.

## Prof. Dr. Eng. Corina NAFORNITA – Vice-Chair of the Synthetic Aperture Radiometry Working Group – IEEE Signal Processing Society Synthetic Aperture Standards (SPSSASC) Committee

• The Institute of Electrical and Electronics Engineers (IEEE) is the world's largest technical professional organization designed to serve professionals involved in all aspects of the electrical, electronic, and computing fields and related areas of science and technology.

In 2022, the Synthetic Aperture Standards Committee (SASC) was formed in the framework of the IEEE Signal Processing Society, in order to develop standards and recommended best practices for applying aperture synthesis to a broad range of disciplines: radar, sonar, channel sounding, optics, MRI, quantum apertures, and radiometry.

• The recommended practice defines arrays of such elements in a number of configurations to establish constraints and performance that accompanies each. It also describes platforms from which instruments operate and the advantages and disadvantages of each setting.

For the preparation of this document, some contributions were already developed, such as:

- H. B. Sequeira, **C. Nafornita**, "Scoping A Document on Recommended Practices for Synthetic Aperture Radiometry", ICASSP June 4-10, 2023 (contributed);
- H. B. Sequeira, **C. Nafornita**, "Calibration of Co-Located Correlation Radiometers" submitted. (To be contributed after publication);
- H. B. Sequeira, **C. Nafornita**, "Calibration of Polarimetric Receivers", in preparation. (To be contributed after publication)

• The Synthetic Aperture Radiometry Working Group Officers are:

**Brian Sequeira** (Johns Hopkins University Applied Physics Laboratories, USA), as Chair;

**Corina Nafornita** (Politehnica University Timisoara, Romania), as Vice-Chair;

Ramesh Annavajjala (University of Massachusetts Boston, USA), as Secretary and Jonathan Goldberg (IEEE, USA), as Program Manager.

• The webpages of the SASC Committee and of the Radiometry Working Group are:

<https://sagroups.ieee.org/sps-sasc/> and  
<https://sagroups.ieee.org/saradiometry/>



• The webpages of the SASC Committee and of the Radiometry Working Group are:

- <https://sagroups.ieee.org/sps-sasc/> and
- <https://sagroups.ieee.org/saradiometry/>

## Prof. Dr. Eng. Erwin-Christian LOVASZ, re-elected as Secretary General of IFToMM

- The International Federation for the Promotion of Mechanism and Machine Science (IFToMM) is one of the most important professional associations worldwide, due to the large number of members who participate in organizing and carrying out a wide range of activities promoting international collaboration in the field. IFToMM (<https://iftomm-world.org/>) was founded in 1969, with 13 founding countries including Romania, and has developed continuously, so that it currently includes 45 affiliated national associations, with a number of over 10,000 members.
- During 05.11-10.11.2023, the XVI<sup>th</sup> World Congress of the Science of Mechanisms and Machines took place in Tokyo, Japan. Our national organization AROtMM – The Romanian Association for the Mechanisms and Machines Science – has proposed a candidate for the position of Secretary General IFToMM, **Prof. Dr. Eng. Erwin-Christian Lovasz**, from the Politehnica University Timisoara. Following the vote in the General Assembly, **Mr. Erwin-Christian Lovasz** was re-elected to this high office for the second term. The presence of **Prof. Dr. Eng. Erwin-Christian Lovasz** in the leadership of IFToMM, as proof of his professional and managerial recognition at international level, honors the structures he represents, respectively the Politehnica University Timisoara and the national organization AROtMM.

We, the undersigned chief delegates at the Inaugural Assembly of the International Federation for the Theory of Machines and Mechanisms (IFTOMM) here at Zakopane Poland on 27th September 1969, declare that we have founded the above-mentioned Federation and that we have adopted its Constitution which is attached hereto and decided to the following categories (see Article 8.4 of the Constitution).

Territory	Chief delegate	Proposed Category	Signature
Australia	JACK PHILLIPS	IV *	<i>[Signature]</i>
Bulgaria	George Rusanov	IV *	<i>[Signature]</i>
German Democratic Republic	Wolfgang Rössner	IV *	<i>[Signature]</i>
German Federal Republic	Werner Thomas	IV *	<i>[Signature]</i>
Hungary	Zénó TERPLAN	IV *	<i>[Signature]</i>
India *	J. S. RAO	IV *	<i>[Signature]</i>
Italy *	Adamo Pavesi	IV *	<i>[Signature]</i>
Poland	Niszei I. Masłowski	IV *	<i>[Signature]</i>
Romania	Ol. Iancuș	IV *	<i>[Signature]</i>
United Kingdom	Douglas Mauder	I	<i>[Signature]</i>
U.S.A.	Douglas Mauder	I	<i>[Signature]</i>
U.S.S.R.	Ivan Artobolevski	I	<i>[Signature]</i>
Yugoslavia	I. Ilic Braniski	I	<i>[Signature]</i>

Academician Ivan Artobolevski (USSR)  
 Prof. Erskine F.R. Crossley (USA)  
 Prof. Mikail S. Konstantinov (Bulgaria)  
 Dr. Werner Thomas (GFR)  
 Prof. B.M. Belgaumkar (India)  
 Prof. Kenneth H. Hunt (Australia)  
 Prof. Jan Oderfeld (Poland)  
 Prof. Jack Phillips (Australia)  
 Prof. George Rusanov (Bulgaria)  
 Prof. Wolfgang Rössner (GDR)  
 Prof. Zénó Terplan (Hungary)  
 Prof. Jamm S. Rao (India)  
 Prof. Giovanni Bianchi (Italy)  
 Prof. Adam Morecki (Poland)  
 Prof. Nicolae I. Manolescu (Romania)  
 Prof. Leonard Mauder (UK)  
 Prof. Douglas Mauder (USA)  
 Prof. Ilic Braniski (Yugoslavia)

The minutes of the establishment of IFToMM



The participants of the 2<sup>nd</sup> IFToMM Congress in Zakopane, Poland 1969 and the minutes of the establishment of IFToMM



Members of the IFToMM Executive Council (2024-2027) newly elected at the General Assembly

## TECHNICAL SCIENCES ACADEMY OF ROMANIA – Associate member „Electronics-Automation” Section Prof. Dr. Eng. Radu Adrian VASIU

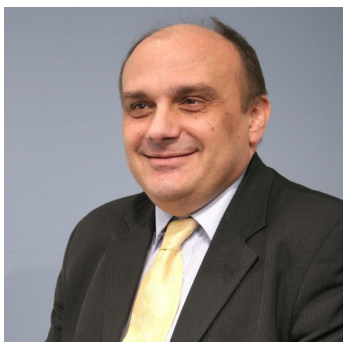

• The Technical Sciences Academy of Romania (ASTR) has the mission of promoting engineering sciences, the development of industry and the improvement of engineering education for the benefit of society. Together with 22 other academies, ASTR is a member of the European Council of National Academies of Engineering, Applied Sciences and Technology (EURO-CASE) and, through it, is part of the European Consortium of Academic Associations, established in 2015, which contains five European academic organizations, including EURO-CASE.

• ASTR includes 10 specialized sections (Technical Mechanics, Mechanical Engineering, Electrotechnics-Energetics, Electronics-Automation, Information and Communication Technology-Computers and telecommunications, Civil Engineering and Urbanism, Transport Engineering, Chemical Engineering, Materials Science and Engineering, Petroleum, Mining and Geonomics Engineering) and 7 branches were organized in the territory. In order to affirm the importance of engineering, several circles affiliated with ASTR were established, addressed mainly to young people, with the mission to present the problems facing society and to stimulate deep knowledge of the interaction between science, technology and the social community.

• **Prof. Radu Adrian VASIU** is a prominent personality, recognized nationally and internationally in the fields of **Virtual / Augmented Reality, Internet of Things, Blockchain Technologies, Advanced Educational Technologies (microcredentials, digital badges), Open Science / Education.**

• Its activity has been dedicated to innovation in the educational, research and administrative infrastructure, by creating sustainable models and centers:

- 1993, establishment of the Technical and Administrative University College

- 1996, establishment of the Multimedia Center

- 1994, creation of the school in Multimedia at UPT, at college level, then Bachelor level and two Master specializations

- Introduction of new courses: Development of multimedia applications, Testing of electronic and telecommunications equipment, Digital television; Audio-video compression, Advanced multimedia technologies, Internet of Things, Design and research management

• International recognition is highlighted by the positions of **president of IAFES (International Association for e-Science) Vienna**, since 2013, **president of EATA (European Association for Telematics Applications) 2009-2013**, **Fellow member of EDEN (European Distance and E-learning Network) since 2020**, **member of IEEE Computer Society.**

• Publishing activity includes 12 books, 5 edited volumes of conference proceedings, 4 student textbooks, 3 monographs, 19 book chapters in foreign publishing houses and over 200 scientific articles in journals or conferences.



**ACADEMIA DE ȘTIINȚE TEHNICE DIN ROMÂNIA**  
**TECHNICAL SCIENCES ACADEMY OF ROMANIA**  
Bd. Dacia nr. 28, sector 1, 010413, București, tel.: (+40 21) 3168993, fax: (+40 21) 3126031  
contact@astr.ro, www.astr.ro

Domnului prof. univ. dr. ing. VASIU Radu Adrian

La Adunarea Generală a Academiei de Științe Tehnice din România (ASTR) din 14 iunie 2023 ați fost ales *membru asociat* în cadrul Secției 4, Electronică - Automatică.

Vă felicităm și așteptăm să luați parte la activitățile specifice academei, să publicați în revista academei **Journal of Engineering Sciences and Innovation (jesi@astr.ro)** și să participați la Zilele ASTR.

Bun venit în Academia de Științe Tehnice din România !

Cu stimă,

Prof. univ. em. dr. ing. Valeriu V. JINESCU  
PREȘEDINTE



## Romanian Academy of Scientists Awards in 2023 - "Martin Bercovici" award for the book: "Science and technology – Paths of progress" Authors: Petru ANDEA and Attila SIMO

- The Romanian Academy of Scientists, on May 19, 2023, gave various prestigious awards during the **Romanian Academy of Scientists Awards Gala**. At this event the group of authors **Petru ANDEA** and **Attila SIMO**, from Politehnica University Timisoara, received the "**Martin Bercovici**" Prize for the book "Science and technology - paths of progress".
- The book **Science and technology - Paths of Progress**, written by a group of recognized professionals in science and academic administration, presents a wealth of didactic material about humanity's scientific and technical accomplishments from ancient times to the present. The work's foundation is the presentation of great scientific theories, as well as the most important technical achievements, primarily of modern means of communication, preceded by a brief history of universal and Romanian science and technology, and followed by legislative notions concerning intellectual and industrial creation protection.
- The book is constructed in such a manner that future professionals in translation-interpretation may develop the essential abilities, beginning with knowledge and comprehension of fundamental ideas, theories, and procedures in science and technology.
- It should be highlighted the accessible language in which the paper is written so that the topics are easily assimilated, avoiding the need for high-level mathematical knowledge.



## Romanian Academy of Scientists Awards in 2023 - „Herman Oberth”award for the book: “Risk Management ” Edited by: Muddasar SARFRAZ and Larisa IVAȘCU

• The prize was officially awarded during the special session “Romanian Academy of Scientists Awards for the year 2021” held in Aula of the “Carol I” Central University Library of Bucharest, on 19<sup>th</sup> May 2023.



• This prize was obtained for the book entitled **Risk Management** coordinated by: Muddassar SARFRAZ and Larisa IVAȘCU.

• Weblink: <https://www.intechopen.com/books/10226>

• Modern globalization has accelerated business and increased competition among economies. Due to excessive industrialization, the world has disturbed its natural ecology, raising concerns about the environment. To mitigate environmental problems, corporate environmental responsibility measures have been suggested. In this regard, emerging economies have also compelled their organizations to adopt risk management measures emphatically. Sustainability is addressed globally due to the opposition between growing needs and limited natural resources. In this context of sustainable development and the dynamics of the business environment, risk management becomes an important process for organizations. An efficient risk management process contributes to achieving organizational goals and vision. These strategic elements, organizational objectives, missions, and visions are important for stakeholders.

• The sustainable development of an organization contributes to local, national, and global development. One cannot talk about development over a long period of time if organizational risks are not addressed. There are a few innovative methods for approaching risks and several attitudes towards risks. These nuances depend on the human personality and the organizational culture.

• Significantly, firms adopt risk management strategies that not only sustain performance but also augment the firms’ reputation. However, it is significant to analyze the role of corporate governance, which can accelerate risk management measures and orient upper management teams towards organizational environmental measures so that firms’ reputation and growth may be sustained in the future.

• This book identifies strategic challenges for risk assessment and management practices, examines potential factors affecting business growth, and provides new sustainable opportunities for businesses. It comprises 15 chapters and covers several important topics in the field of global sustainability and environmental dynamics, as follows: the role of technological innovation and corporate risk management, challenges of corporate governance, the relationship between environmental risk management and sustainable management, strategic responsibility of the corporate environment under the influence of cultural barriers, risk management in different countries (International dimensions), global standardization versus local adaptation of corporate environmental risk management in multinational corporations and approaches to short, medium and long term risk management strategies.



• This book is a useful resource for both practitioners and researchers. It also provides several introductory aspects for those who want to get started in the field of risk. The innovative methods and models of risk management contribute to the advancement of specialized literature through the multidisciplinary approach to the aspects of **risk management** and **sustainability**.

## PatriotFest Gala, fifth edition, January 2023 Second Prize at the category “Innovation for Security”, Assoc. Prof. Dr. Eng. Raul IONEL The “Patriotfest Hope” Award, Assoc. Prof. Dr. Eng. Georgiana SIMION

- **PatriotFest Gala**, the fifth edition, was organized by the **New Strategy Center** association, with the support of national security institutions: MAI, SRI, MAPN, SPP and STS.

- Two professors from the Politehnica University Timisoara, members of the research group „Intelligent Embedded Vision”, IEV@UPT, received the following awards, at PatriotFest, national innovation competition held in January 2023:

- **Second Prize** in the category “Innovation for Security”, for the project: “**Boundary Scan – evaluation of the quality of electronic boards**”, author Assoc. Prof. Dr. Eng. Raul IONEL. **Boundary Scan technology** is a modern method in non-invasive assessment of the quality of electronic boards. It quickly detects production defects, such as short circuits, interruptions or even the lack of components;

- “**PatriotFest Hope**” Award: **Georgiana SIMION** for the project „**AI system for automatic diagnosis of liver lesions**”, UPT and UMFT authors represented by Assoc. Prof. Dr. Eng. Georgiana SIMION. The system proposed is able to even detect the five most common types of liver damage, and not just to apply labels of malignant or benign. Accuracy is comparable to top medical expertise.

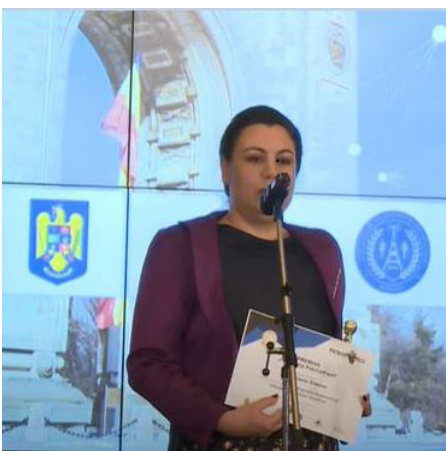

„Gold Best Application Paper Award” and „Springer Best Application Paper” presented at MESROB 2023 for the paper „The Use of Accelerometers to Track Changes in Cobb Angles During Scoliosis Rehabilitation Exercises”, Authors: Ana-Maria VUTAN, Corina GRUESCU, Carmen STICLARU and Erwin-Christian LOVASZ

- The work entitled „The Use of Accelerometers to Track Changes in Cobb Angles During Scoliosis Rehabilitation Exercises”, authored by members of the Department of Mechatronics at the Politehnica University Timisoara (Ana-Maria Vutan, Corina Gruescu, Carmen Sticlaru, Erwin-Christian Lovasz) won the Gold Best Application Paper Award at the conference The 8<sup>th</sup> International Workshop on New Trends in Medical and Service Robotics, MESROB 2023, traveling international conference, held under the auspices of IFToMM in Craiova on June 7-10, 2023.
  - The work entitled „The Use of Accelerometers to Track Changes in Cobb Angles During Scoliosis Rehabilitation Exercises”, authored by members of the Department of Mechatronics at the Politehnica University Timisoara (Ana-Maria VUTAN, Corina GRUESCU, Carmen STICLARU, Erwin-Christian LOVASZ) won the Gold Best Application Paper Award at the conference The 8<sup>th</sup> International Workshop on New Trends in Medical and Service Robotics, MESROB 2023, traveling international conference, held under the auspices of IFToMM in Craiova on June 7-10, 2023.
  - The work was also offered the Springer Best Application Paper Award by the editor of the Mechanism and Machine Science prestigious series, now in volume 140 in Springer Publishing House.
  - The effectiveness of specific physical exercises for the scoliosis rehabilitation is a topic that is still being discussed in the medical world and orthopedic doctors and physiotherapists have not reached a consensus. Mild and moderate scoliosis benefits from exercise treatment from the moment the deficiency is detected.
- The value of the Cobb angle is taken into consideration to observe the evolution of a scoliosis and the effectiveness of the treatment carried out, but this is generally done by taking repeated x-rays every 6 months. The study follows the changes that the Cobb angle undergoes during physical exercises specific to scoliosis in the case of a group of 9 subjects diagnosed with mild and moderate scoliosis. Cobb angle values are calculated mathematically by using approximation polynomials. The conclusions of the study are useful for the therapist, who can plan personalized exercise programs adequate to each patient.



## 2023 Excellence Awards Gala at Politehnica University Timisoara: Award „Excellence in research” - young researchers, Assoc. Prof. Dr. Eng. Anamaria FEIER Award „Excellence in research” - young doctoral students, Eng. Ioana Cristina BENEĂ, doctoral student

• At the end of the year, Politehnica University Timisoara awarded the “Excellence in Research” prizes to young people who achieved remarkable results during the academic year 2022-2023.

The „Excellence in research” award at the young researchers section was conferred on Assoc. Prof. Dr. Eng. Anamaria FEIER from the Faculty of Mechanical Engineering in Timisoara.

• During the academic year 2022-2023 Assoc. Prof. Dr. Eng. Anamaria FEIER published 10 articles in journals and conference proceedings, indexed by Thomson Reuters. Throughout her academic activity she is author and co-author of more than 120 papers published in International Conferences and Journals in Industrial Engineering, Welding Engineering and Civil Engineering, 34 of them are indexed Web of Science (1 article Q1, 3 articles Q2, 2 articles in Q3, 8 articles Q4).

• Anamaria FEIER is currently Associate Professor at the Materials and Manufacturing Engineering Department, Faculty of Mechanics, from the Politehnica University Timisoara;

• She is also associated researcher at ASR (Romanian Welding Society);

• Her skills were acquired as a result of the sedimentation of knowledge from related fields studied: **Hydrotechnical Construction, Steel Construction and Welding (Civil Engineering and Industrial Engineering);**

• Project Manager / Scientific Responsible for 6 national projects;

• Research team member for 10 international projects (H2020, FP6, ERASMUS+, LLP) and 5 national projects (POSDRU, PNCDI, PN II, PN III);

• More than 90 papers reviewed in the last 3 years.



• The award of excellence in Research at the young doctoral students section was offered to Eng. Ioana Cristina BENEĂ, PhD student at the Faculty of Industrial Chemistry and Environmental Engineering, for outstanding research results reflected in publications, grants participations or research internships.

## International Exhibition of Inventics BAP-INVENT, Backa Palanka, Serbia, March 4-5, 2023 Gold medals and awards for the Politehnica University Timisoara

- During March 4-5, 2023, the team of the UPT Innovation and Technology Transfer Center participated with two projects in Backa Palanka, Serbia, at the BAP-INVENT International Salon, organized by the Association of Inventors and Innovators of Serbia UPI-CIB.
- The UPT team has been rewarded with the following distinctions:
  - 2 Gold Medals;
  - 4 Special Awards;
  - 4 Diplomas of Excellence
- The first project is a new concept of over-aspiring air filter YXV developed within the InoHubDoc project by postdoctoral researcher Corneliu Birtok-Băneasă.
- The second project is the "DEXTER" Laboratory Educational Program for students, in order to carry out student projects.
- Within the international salon BAP-INVENT 2023 was also presented the project PUMA AIR by CORNELIU, at which the students from the Faculty of Engineering of Hunedoara work and through which they want to convert a series car into a race car.
- The Puma Air by Corneliu project received a gold medal, along with a special award for Politehnica University Timisoara.
- The educational program Laboratory of "DEXTER" received a gold medal.
- Lecturer Dr. Eng. Corneliu Birtok-Băneasă presented the paper "Research and Innovation in the Industrial Age 4.0", with a focus on technology transfer activity within the Politehnica 2020 Innovation and Technology Transfer Center.
- The jury rewarded the project The over-aspiring air filter YXV with: special BAP award, Nikola Tesla award and a gold medal.



## The 17<sup>th</sup> edition of INVENTUM, International Exhibition of Innovation, Economics and Technical Creativity, ILOK, Croatia, 31 March-1 April 2023 Gold medals and special prizes for the Politehnica University Timisoara

• The 17<sup>th</sup> edition of **INVENTUM, International Salon of Innovation, Economics and Technical Creativity**, was held in **ILOK Croatia** from 31 March to 1 April 2023. The fair was organized by the **Tesla Innovators' Association of Croatia** and supported by the **Croatian Association of innovators** and authorities there.

• **Lecturer Dr. Eng. Corneliu Birtok-Băneasă** represented Politehnica University Timisoara with two projects. He was both coordinator of one project and inventor of the other. **Two gold medals** and **two special prizes** were awarded, as follows:

• **Gold Medal:** Corneliu Birtok-Băneasă, Adina Budiul Berghian, Diana Stoica, Oana Găianu: **Dexter's laboratory educational program**, Politehnica University Timisoara,

• **Special award** from **UPI-ČIB-** Association of Inventors and Innovators from Bačka Palanka municipality: **Golden award**, awarded to Corneliu Birtok-Băneasă, mentor: Prof. Dr. Eng. Habil. Virginia Ana Socalici for **A-S-F super-aspirated air filter**.

• **Gold Medal:** Corneliu Birtok-Băneasă: **A-S-F super-aspirated air filter**, Politehnica University Timisoara

• **Special award** from **UPI-ČIB-** Association of Inventors and Innovators from Bačka Palanka municipality: **Golden award**, awarded to Corneliu Birtok-Băneasă, Adina Burghiul Berghian, Diana Stoica, Oana Găianu for **Dexter's Laboratory Educational Program**

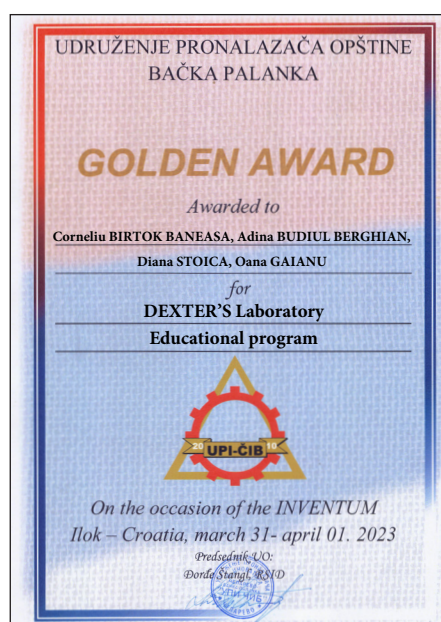

# Research Report 2023

## 15<sup>th</sup> European Exhibition of Creativity and Innovation “EUROINVENT 2023” Iasi, 11-13 May 2023 Multiple medals and awards for Politehnica University Timisoara

• Politehnica University Timisoara participated between 11-13 May 2023 at the Euroinvent International Salon in Iasi, the 15<sup>th</sup> edition, with 41 patents, research projects, doctoral theses, doctoral theses, student projects and 5 publications.

• Politehnica University Timisoara was represented by the team coordinator, Lecturer Dr. Eng. Corneliu Birtok-Băneasă.

• The following performances were achieved:

- Synergy Award (C.I.T.T. Politehnica University Timisoara);
- 11 Diplomas of Excellence;

- 18 Gold Medals;

- 6 Silver Medals;

- 6 Bronze Medals

Virtual catalog:

[https://www.euroinvent.org/cat/EUROINVENT\\_2023.pdf](https://www.euroinvent.org/cat/EUROINVENT_2023.pdf)





## The International Exhibition of Inventions and Innovations “TRAIAN VUIA” Timișoara, 9<sup>th</sup> edition, 15 - 17 June 2023 Multiple medals and awards for Politehnica University Timisoara

• International Salon of Inventions and Innovations “TRAIAN VUIA” 2023, the ninth edition, was organized between 15-17 June by King Michael I University of Life Sciences in Timisoara in partnership with the Banat Inventors Society. This salon is a scientific event that has become a brand of the city of Timisoara, which in 2023 is not only the European Capital of Culture, but also the capital of Romanian and international invention.

• The team of the Innovation and Technology Transfer Center of the Politehnica University Timisoara, represented by Lecturer Dr. Eng. Corneliu Birtok-Băneasă participated with 41 entries quantified in patents, research projects, results from doctoral theses.

• Numerous medals and awards were obtained: **8 gold medals, 33 silver medals, 2 special prizes from Continental company, a special award from Lucian Blaga University of Sibiu.**  
• The most important award received at the Salon is the **Excellence Award for the Politehnica University Timisoara.**



## The 27<sup>th</sup> International Exhibition of Inventics “Inventica 2023” Iasi, 21-23 June 2023 Multiple medals and special awards for Politehnica University Timisoara

- The team of the Politehnica University Timisoara participated in the International Exhibition of Inventions – **INVENTICA 2023 Iasi** – 27<sup>th</sup> edition, held between 21-23.06.2023, with 41 project entries. The international exhibition of inventions was organized by the **Technical University „Gheorghe Asachi” of Iasi** and the **National Institute of Inventics of Iasi**.
- The International Jury appreciated the complexity, the diversity and the level of the works of the CITT-UPT team, which received the following awards: **9 Special Awards, 15 Gold Medals, 17 Silver Medals and 9 Bronze Medals**.



## International Exhibition IDEA-EXPO 2023 Hódmezővásárhely - Hungary, 23-25 June 2023 Multiple awards and medals for the Politehnica University Timisoara

• Between 23-25 June 2023, there took place the International Exhibition IDEA-EXPO 2023 in Hodmezovasarhely, Hungary. IDEA International Exhibition of Inventics has been organized annually since 1999, by the IDEA Club 13 Association (Otdlet Club 13 Egyesulelet), bringing together inventors and researchers from all over the world.



- Achievements of the Politehnica University Timisoara:

• **Pavel Ștefan, Viorel Ungureanu** have been awarded the **Gold medal award**

Name of invention: Installation for cleaning lighting fixtures with diffuser and fluorescent tubes or LEDs

• **Pavel Ștefan, Viorel Ungureanu, Pascu Ioan-Bogdan** have been awarded the **Gold Medal Award**

Name of invention: Installation used for the collection and storage of the microparticles resulted from the wear of car brakes

• **Daniela-Nicolia Pătruș, Larisa Ivașcu, Mădălin-Dorin Pop, Matei Tămășilă, Alin Artene, Alexandra Coroian, Timea Cisma, Andrei Agache** have been awarded the **Gold Medal Award**

Name of invention: EduFinUPT -Mobile Application for Acquiring Financial Skills

• **Emilia Dobrin, Sorin Musuroi, G.-V. Mnerie, C.M. Matei**, have been awarded the **Gold Medal Award**

Name of invention: Method for obtaining a reinforced alveolar structure

• **Emilia Dobrin, Sorin Musuroi, G.-V. Mnerie, C.M. Matei** have been awarded the **Gold Medal Award**

Name of invention: Process for obtaining a reinforced alveolar structure

• **Susan-Resiga Romeo Florin, Bosioc Ilie Alin, Tanasa Constantin, Stuparu Adrian Ciprian, Szakal Raul Alexandru** have been awarded the **Gold Medal Award**.

Name of invention: Instabilities generated by the swirling flow from the conical diffuser of hydraulic turbines

• **Ioan Silea, Romina Druta**, have been awarded the **Gold Medal Award**

Name of invention: Distributed system and method for remote technical assistance to flexible manufacturing cells

## Fourth edition of International Exhibition "InventCor" Deva, 14-16 September 2023 Multiple medals and awards for the Politehnica University Timisoara

• CORNELIUGROUP Research-Innovation Association, in collaboration with the Faculty of Engineering Hunedoara - Politehnica University Timisoara, organized the International Exhibition INVENTCOR, 4<sup>th</sup> edition, between 14 and 16 September 2023, in a hybrid format, at the Cultural Center „Drăgan Muntean” from Deva city.

• The Power of Creative Mind Symposium was held within INVENTCOR with presentations on various topics: innovation, ecology, health, community, intellectual property and others.

• Virtual Catalog: <https://corneliugroup.ro/catalog2023.pdf>

Coodinator: Lecturer. Dr. Eng. Corneliu Birtok Băneasă

Here are some of the outstanding awards:

• Florin Dragan, Marius Pislaru and Larisa Ivascu from the Politehnica University Timisoara, Research Center for Engineering and Management have been awarded with Certificate of Excellence for the project: "Integrated intelligent system for environmental sustainability assessment -Intel-Green"

• Mircea Nicolaescu, Cornelia Bandas, Corina Orha, Carmen Lazău and Viorel Șerban from the Politehnica University Timisoara, National Institute for Research and Development in Electrochemistry and Condensed Matter have been awarded with Diploma and Gold Medal for the Doctoral research project "The development of environmental monitoring sensors based on n-TiO<sub>2</sub>/p-CuMnO<sub>2</sub> oxide heterojunctions".

• Ciprian-Bogdan CHIRILĂ and Omar MOHAMED, from the Politehnica University Timisoara, have been awarded with Diploma and Gold Medal for the paper "Malware detection based on performance counters using deep learning classification models"

• Pavel Ștefan, Viorel Ungureanu and Pascu Ioan-Bogdan, from the Politehnica University Timisoara, have been awarded with Diploma and Gold Medal for "Installation used for the collection and storage of microparticles resulted from the wear of car brakes A / 000805/09.12.2022".

• Emilia Dobrin, Sorin Mușuroi, G.- V. Mnerie and C.M. Matei, from the Politehnica University Timisoara, National R & D Institute for Welding and Material Testing, have been awarded with Diploma and Gold Medal for the paper "Method for obtaining a reinforced alveolar structure A / 00078 /20.02.2023"

• Emilia Dobrin, Sorin Mușuroi, G.- V. Mnerie and C.M. Matei, from the Politehnica University Timisoara, National R & D Institute for Welding and Material Testing, have been awarded with UPI ČIB – Srbija: Special Award for the paper "Method for obtaining a reinforced alveolar structure A / 00078 /20.02.2023"

• Lupa Lavinia, Cocheci Laura, Țolea Nick Samuel and Lazău Radu, from the Politehnica University Timisoara, have been awarded with Diploma and Gold Medal for the paper "Method of platinum recovery and capitalization from residual aqueous solutions A/00056/08.02.2023"

• Ioan Silea and Romina Druta, from the Politehnica University Timisoara, have been awarded with Diploma and Gold Medal for the paper "Distributed system and method for remote technical assistance to flexible manufacturing cells A/2022/00047"

• Pavel Ștefan and Viorel Ungureanu from the Politehnica University Timisoara, have been awarded with Diploma and Gold Medal for "Installation for cleaning lighting fixtures with diffuser, and fluorescent tubes or LEDs, mounted on the ceiling A/000806/09.12.2022"



## The International Salon of Invention and Innovative Entrepreneurship, Chișinău, 12 - 13 October 2023 Multiple medals and awards for Politehnica University Timisoara

• The International Salon of Inventions and Innovative Entrepreneurship was held on 12-13 October 2023 and was organized by the Research Institute, Innovation and Technology Transfer of the State Pedagogical University „Ion Creanga” from Chisinau. During the salon, the International Congress of Research - Innovation - Innovative Entrepreneurship took place, where the team coordinator and Lecturer Dr. Eng. Corneliu Birtok-Băneasă presented the paper entitled “Eco Drift – Air Power by Corneliu”.

• The portfolio presented at the salon included 38 papers, namely patents, research projects, doctoral theses, student projects and monographs.

• Virtual catalog:

<https://conferinte.stiu.md/sites/default/files/evenimente/PROGRAM%20SALON.pdf>

• The CITT UPT team won the **Grand Prize for Promoting Innovation Excellence**, and also the **Special Award for Entrepreneurship**, 25 gold medals, 7 silver medals, 4 bronze medals.



## 21<sup>st</sup> International Exhibition of Scientific Research, Innovation and Invention “PRO INVENT 2023” Cluj Napoca, edition, 25-27 October 2023 Multiple medals and awards for Politehnica University Timisoara

- The UPT team participated at the International **Salon of Scientific Research, Innovation and Inventions PRO INVENT Cluj**, the XXI-th edition, organized between 25-27 October 2023 by the Technical University of Cluj-Napoca.
- The participation of the UPT team was carried out under the aegis of the Innovation and Technology Transfer Center – Politehnica 2020. The team had 10 patents, a research project and 9 projects carried out by students.
- Virtual catalog: <https://proinvent.utcluj.ro/img/catalogs/2023.pdf>

• It was really worthwhile to receive the **Grand Prize of the Technical University of Cluj-Napoca**.

Apart from this important award, the UPT team has been rewarded with the following distinctions:

- **First Prize** - Category Students
- **6 Special awards** offered by participating entities, including gold, silver and bronze medals.
- **6 Diplomas of Excellence** and the **Pro Invent Medal**
- **2 Diplomas of Excellence** and the **gold medal**



## The UGAL INVENT Innovation and Research Salon, Galati, 6<sup>th</sup> edition, 9 - 10 November 2023

### Multiple medals and awards for Politehnica University Timisoara

- The Innovation and Research Salon **UGAL INVENT**, the sixth edition, was held between 9 and 10 November 2023. The organization belongs to the University „Dunarea de Jos” of Galati and Black Sea Universities Network, with the support of the City Hall of Galati. The partnership is provided by: Academy of Technical Sciences of Romania (ASTR), Technical University of Moldova, National Institute of Inventics of Iasi, Romania, The General Association of Engineers in Romania (AGIR) and the Romanian Inventors Forum (FIR).
- This event is an excellent opportunity offered to inventors to make their inventions known both in the industrial environment, as well as the general public and a good opportunity for researchers from the country and abroad to establish successful collaborations.
- The team of the Innovation and Technology Transfer Center of the Politehnica University Timisoara, represented by Lecturer Dr. Eng. Corneliu Birtok-Băneasă obtained the following performances: **9 gold medals, 2 silver medals, 4 bronze medals, 2 special awards, 1 diploma of excellence.**







# NATIONAL RESEARCH PROJECTS



## DATA-DRIVEN FUZZY CONTROL WITH EXPERIMENTAL VALIDATION (DAFUCON)

### Goal of the project

The main goal of this project is to develop new data-driven fuzzy controllers for nonlinear processes. The achievement of this objective requires the achievement of several particular goal during the three years of the project. Please visit: <https://www.aut.upt.ro/~rprecup/grant2021.html> for additional details.

### Short description of the project

Fuzzy controllers are an important part of the general class of nonlinear controllers as they are relatively easily understandable and also offer very good control system performance. An alternative to the classical model-based control is represented by data-driven control (DDC), a hot topic in academia and industry as well. This project proposes the development of new data-driven fuzzy controllers for nonlinear processes with shape memory alloy actuators in order to benefit from the advantages of both fuzzy control and DDC.

### Project implemented by

The Process Control Group of UPT and the Research Center for Automatic Systems Engineering

### Implementation period

04.01.2021 – 31.12.2023

### Main activities

1. The analysis, design and implementation of new DDC algorithms;
2. The analysis, design and implementation of new fuzzy control algorithms;
3. The analysis, design and implementation of three new data-driven fuzzy control algorithms;
4. The validation of the new control algorithms by experiments conducted on laboratory equipment that may include shape memory alloy actuators;
5. The validation of the proposed control algorithms as controllers for real-world processes;
6. The dissemination of results focusing on high visibility journals and important conferences;
7. Solving the project management issues.

### Results

Overall: **7 papers** published in **Clarivate Analytics Web of Science (formerly ISI Web of Knowledge) journals with impact factor**, cumulated impact factor according to 2021 Journal Citation Reports (JCR) released by Clarivate Analytics in 2022 = 26.128, 2 papers published in conference proceedings indexed in Clarivate Analytics Web of Science (formerly ISI Web of Knowledge or ISI Proceedings), **8 papers** published in conference proceedings indexed in international databases (IEEE Xplore, INSPEC, Scopus, Scencedirect, Springer Link, DBLP).

Specific results:

1. One research report.
2. **3 certificates** that register to the Romanian Office of Copyright (Oficiul Român pentru Drepturile de Autor, ORDA) the works "Study of design and industrial implementation of a hybrid model-free fuzzy controller", no. RGII/INT/1838/02.05.2023 - RGII/IES/1838/08.05.2023, "Study of design and industrial implementation of a hybrid model-free adaptive fuzzy controller", no. RGII/INT/2607/23.06.2023 - RGII/IES/2607/20.07.2023, "Study of design and industrial implementation of a fuzzy controller with proportional-derivative indirect iterative learning", no. RGII/INT/3514/29.08.2023 - RGII/IES/3514/28.09.2023.
3. M. Brezovan, **R.-E. Precup** (corresponding author), D. Selișteanu and L. Stănescu, Colored Petri nets-based control and experimental validation on three-tank system level control, International Journal of General Systems (Taylor & Francis), vol. 51, no. 1, pp. 1-47, 2023, impact factor according to 2021 Journal Citation Reports (JCR) released by Clarivate Analytics in 2022 = 2.435.
4. I. A. Zamfirache, **R.-E. Precup** (corresponding author), R.-C. Roman and E. M. Petriu, Neural Network-based Control Using Actor-Critic Reinforcement Learning and Grey Wolf Optimizer with Experimental Servo System Validation, Expert Systems with Applications (Elsevier), vol. 225, paper 120112, pp. 1-15, 2023, impact factor according to 2021 Journal Citation Reports (JCR) released by Clarivate Analytics in 2022 = 8.665;
5. A.-I. Borlea, **R.-E. Precup** (corresponding author) and R.-C. Roman, Discrete-time model-based sliding mode controllers for tower crane systems, Facta Universitatis, Series: Mechanical Engineering (University of Nis), vol. 21, no. 1, pp. 1-20, 2023, impact factor according to 2021 Journal Citation Reports (JCR) released by Clarivate Analytics in 2022 = 4.622.
6. R.-C. Roman, **R.-E. Precup** (corresponding author), E. M. Petriu and M. Muntyan, Fictitious Reference Iterative Tuning of Discrete-Time Model-Free Control for Tower Crane Systems, Studies in Informatics and Control (ICI Bucharest), vol. 32, no. 1, pp. 5-14, 2023, impact factor according to 2022 Journal Citation Reports (JCR) released by Clarivate Analytics in 2023 = 1.6.

7. C. Pozna and R.-E. Precup, On the Use of Quaternions, in the Translated Reference Frame Formalism, Acta Polytechnica Hungarica, vol. 20, no. 6, pp. 195-214, 2023, impact factor according to 2020 Journal Citation Reports (JCR) released by Clarivate Analytics in 2021 = 1.806.

### Applicability and transferability of the results

The controllers are ready to implement in industry.

### Financed through/by

UEFISCDI

### Research Center

Research Center for Automatic Systems Engineering

### Research Team

- Prof. Dr. Eng. Radu-Emil PRECUP - director, principal investigator
- Assoc. Prof. Dr. Eng. Claudia-Adina BOJAN-DRAGOȘ - experienced researcher
- Assoc. Prof. Dr. Eng. Adriana ALBU - experienced researcher
- Lecturer Dr. Eng. Alexandra-Iulia SZEDLAK - STÎNEAN - experienced researcher
- Lecturer Dr. Ioan-Ciprian HEDREA - experienced researcher
- Lecturer Dr. Eng. Raul-Cristian ROMAN - postdoc
- Ph.D. Student Ion-Cornel MITULEȚU
- Assist.Prof.Dr.Eng. Elena-Lorena HEDREA

### Contact information

Prof. Dr. Eng. Radu-Emil PRECUP  
Faculty of Automation and Computers,  
Department of Automation and Applied Informatics  
Address: 2, Vasile Pârvan Blvd., 300223, Timisoara  
E-mail: radu.precup@aut.upt.ro  
Phone: (+40) 256 403 213  
Web: <http://www.aut.upt.ro/~rprecup/>  
Project Website:  
<http://www.aut.upt.ro/~rprecup/grant2021.html>

## EFFICIENCY INCREASE IN WATER DOMAIN SYSTEMS FUNCTIONING THROUGH PROACTIVE SUPERVISION

### Goal of the project

The objective of the project is to provide tested and validated solutions to increase efficiency of water domain systems functioning, in the IIoT context, targeting a proactive supervision. The solutions are focusing on a proactive historian targeting efficiency improvements of water domain systems, on securing local structures that are interfacing on legacy protocols, respectively on a flexible and configurable supervision of processes using the OPC UA protocol and mobile devices.

### Short description of the project

The project proposes to increase the efficiency of water domain systems functioning through proactive supervision, in the IIoT context, providing two tested and validated solutions contributing to reduce costs of water producing-treatment-distribution, wastewater collection-treatment, the environmental impact, and to increase water, wastewater quality and the availability of services. The first solution refers to a water system oriented, low-cost and platform independent proactive historian, in a decentralized concept, integrated non-invasively with the local structures. The proactive historian will accumulate data according to technological process patterns, constraints and objective functions, will generate dependencies and conclusions, respectively it will elaborate and apply efficiency increasing recipes on local control structures. In connection with the proactive historian, to increase the applicability area, a security solution is developed for the communication on legacy protocols. The second solution refers to a monitoring and control application focused on water domain processes, for mobile devices with Android operating system and OPC UA interfacing with local systems.

### Project implemented by

- **Coordinator:** Aquatim
- **Partner:** Politehnica University Timisoara

### Implementation period

27.06.2022-27.12.2023

### Main activities

#### Phase 1 (2022):

Researching and developing proactive supervisory solutions in the water domain, to enable the pilot structures.

#### Phase 2 (2023):

Researching and developing proactive supervisory solutions in the water domain, within the pilot structures.

### Results

#### Phase 1 results:

1. Pilot structures in function for the proactive historian in the operational environment;
2. TPM-based security solutions for legacy structures finalized for the local automation;
3. The Android and OPC UA based supervisory solution is structured for the operational environment.

#### Phase 2 results:

1. A decentralized low-cost process-aware proactive historian was obtained, validated in the industrial environment, that is able to identify in the data dependencies, to generate efficiency increasing recipes and to react over the local legacy system. The most significant results for drinking water were: reducing the energy consumption of a water facility by prioritizing water sources, correcting and automating the water well selection procedure and distributing the demanded flow to eliminate water scarcity in the distribution reservoirs considering filter washing stages and peak demands. The most significant results for wastewater were: predicting faults and indicator values using artificial intelligence, particularly LSTM neural networks, obtaining 5 hours future predictions for sludge pump faults and a water quality indicator.
2. TPM and elliptic curves based security solutions were obtained that allow securing the legacy systems in various configurations, including historian integration. The research approached practically the Modbus TCP legacy protocol, but they were extended to the OPC UA protocol.
3. An Android SCADA application based on OPC UA was obtained and validated in the industrial environment. The application represents a convenient alternative for the water operator from both technical and financial perspectives. The concept with a central development/ update/ download software nucleus, and with the possibility of individual SCADA development and runtime on the mobile device, offers maximal flexibility, adaptability and extensibility.

## Applicability and transferability of the results

- The applicability and transferability of results is assured by solutions that are applied in the operational environment. All historians are in function within water and wastewater treatment facilities and are interfacing real automation systems. All efficiency increasing solutions are using real data and have impact on the operational level. The four proactive historian pilots were successfully deployed within functioning legacy systems in a completely non-invasive manner over local developments.

- The activities related to securing legacy protocols are also considering the rapid applicability in real scenarios and also minimal interference over functioning systems during deployment. The Android and OPC UA mobile supervising solution is focused on OPC UA interfacing that was tested using various real and functioning local automation/SCADA systems and also using various future specifications that are in research and not yet available in the industry, respectively the foreseen pilots will be tested in real scenarios.

## Financed through/by

- UEFISCDI

## Research Team

### Project leader:

- Assoc. Prof. Dr. Eng. Adrian KORODI

### Researchers:

- Dr. Inf. Andrei-Mihai NICOLAE

- Prof. Dr. Eng. Ioan SILEA

- Lect. Dr. Eng. Octavian ȘTEFAN

- Lect. Dr. Eng. Ruben-Dan CRIȘAN

- Ph.D. Student Inf. Alexandra ȚIDREA

- Ph.D. Student Inf. Ana-Maria MATEOIU

- Ph.D. Student Inf. Alexandru IOANA

- MSc. Eng. Silviu-Iulian TOC

## Contact information

Assoc. Prof. Dr. Eng. Adrian KORODI

Faculty of Automation and Computers

Department of Automation and Applied Informatics

Address: 2, Vasile Pârvan Blvd., 300223, Timisoara

Phone: (+40) 256 403231

E-mail: [adrian.korodi@upt.ro](mailto:adrian.korodi@upt.ro)

Project Website:

<http://eficient.aut.upt.ro/>

## ARTIFICIAL INTELLIGENCE BASED CONTROL SYSTEM FOR LEGGED ROBOTS USED IN AUTONOMOUS NAVIGATION, MAPPING AND SURVEILLANCE OF UNSTRUCTURED ENVIRONMENTS

### Goal of the project

The scope of the **AI-LegRob (Artificial Intelligence based Control System for Legged Robots used in Autonomous Navigation, Mapping and Surveillance of Unstructured Environments)** project is to build an Artificial Intelligence sense-and-control system based on multitasking Deep Neural Networks (DNN) for controlling 4-legged robots used in autonomous navigation on unstructured terrain. The objectives of this project are: **01:** AI-based Environment Perception and Terrain Estimation; **02:** 4-legged robot motion control; **03:** Connectivity, mapping, and data collection; **04:** Case Studies.

### Short description of the project

The objective of **AI-LegRob** is to build an Artificial Intelligence based system for controlling a legged robot which continuously monitors, maps, and centralizes the state of its environment.

### Project implemented by

**Coordinator:** Transilvania University Brașov (UTBv)

**Partner:** Politehnica University Timișoara (UPT)

### Implementation period

30.06.2022 – 20.06.2024

### Main activities

The **AI-LegRob** project is planned to be implemented through four technical Work Packages (WP), over 2 years of activity, with an additional fifth management, exploitation, and dissemination work package:

**WP1:** Multitasking DNN for scene and terrain perception

Task 1.1. Synthetic training data generation

Task 1.2. Multitasking perception DNN

**WP 2:** AI-based motion control for legged robots

Task 2.1. Classical baseline predictive control for 4-legged robots

Task 2.2. AI-based data driven control for legged robots

**WP 3:** Data connectivity and legged robotics database

Task 3.1. 4-legged robotics connectivity

Task 3.2. Real-world training data

Task 3.3. Dynamic map

**WP 4:** Evaluation and Case Studies

Task 4.1. Rovis.Dojo simulation and RovisLab AMTU tests

Task 4.2. Indoor evaluation

Task 4.3. Evaluation on forest roads

**WP 5:** Management, Exploitation and Dissemination

Task 5.1 Management

Task 5.2 Exploitation plan

Task 5.3 Dissemination

### Results

- In the first six months of the project's implementation, the consortium concentrated on developing the necessary infrastructure. The main hardware device used in the AI LegRob project is the **Unitree A1 4-legged robot**.

The definition of the training database was made according to the sensorial systems of the robot, creating several data acquisition libraries.

- A first training database was generated through manual control of the robot into an unstructured environment on a forest road near Brașov. Figure 1 is an image taken during the experiments. The data acquisition system of the robot was activated, therefore, the information read from different sensors was stored.

- A perception neural network was implemented to label the images as: accessible area, person, obstacle, vegetation, sky. The semantic information obtained from the convolutional neural network is used to control the motion trajectory of the robot. The first step was to define a low-level control based on the cinematic model.

## Applicability and transferability of the results

From a technological perspective, AI-LegRob aims to enhance the autonomy of legged robotic systems designed to navigate unstructured terrain. AI-LegRob will deliver a distributed robotic system demonstrator for navigating forest roads, starting from available technologies, previously developed by the consortium partners in the area of AI-based computer vision, mobile robotics, autonomous driving and control systems.

To the best of our knowledge, there is no AI-based data-driven automated controlled technology for 4-legged robots used to navigate and monitor unstructured environments such as forest roads.



## Financed through/by

UEFISCDI (PN-III-P2-2.1-PED-2021-4587)

## Research Center

- RovisLab (Robotics, Vision and Control Laboratory), Transilvania University Braşov,

<https://rovislab.com/>

- CCISA (Research Center for Automatic Systems Engineering), Politehnica University Timișoara,

<https://www.aut.upt.ro/centru-cercetare/index.EN.php>

## Research Team

**Project leader (UTBv):** Prof. Dr. Eng. Sorin GRIGORESU

**Partner leader (UPT):** Assoc. Prof. Dr. Eng. Adriana ALBU

### Researchers (UTBv):

- Prof. Dr. Eng. Dorian COJOCARU
- Prof. Dr. Eng. Claudiu POZNA
- Ph.D. Student Eng. Mihai-Valentin ZAHA
- Assoc. Prof. Dr. Eng. Lucian-Mirea SASU
- Eng. Bogdan MUNTEAN
- Alexandra ENACHE
- Ph.D. Student Cosmin GINERICA

### Researchers (UPT):

- Prof. Dr. Eng. Radu-Emil PRECUP
- Lecturer Dr. Eng. Raul-Cristian ROMAN
- Ph.D. Student Eng. Monica-Lavinia NEDELCEA
- Ph.D. Student Eng. Miruna-Maria DAMIAN

## Contact information

Assoc. Prof. Dr. Eng. Adriana ALBU

Faculty of Automation and Computers

Automation and Applied Informatics Department

Address: 2, Vasile Pârvan Blvd., 300223, Timișoara

E-mail: [adriana.albu@upt.ro](mailto:adriana.albu@upt.ro)

Project Website: [https://rovislab.com/ai\\_legrob.html](https://rovislab.com/ai_legrob.html)



## DYNAMICS OF HYPERCOMPLEX-VALUED NEURAL NETWORKS

### Goal of the project

- The main goal of the project is to study stability and synchronization properties of quaternion, octonion, Clifford, and matrix-valued recurrent neural networks. More precisely, sufficient conditions given in terms of linear matrix inequalities for the stability and synchronization, using different control schemes, of quaternion-valued Hopfield and fractional-order neural networks with neutral-type, leakage, time-varying, and/or distributed delays on time scales will be derived using techniques and methods extended from the real- and complex-valued domains.
- Further extending these ideas to the octonion domain, sufficient conditions for the stability and synchronization of octonion-valued Hopfield and fractional-order neural networks with the same types of delays on time scales will also be obtained. The stability and synchronization analysis of Clifford-valued Hopfield and fractional-order neural networks with delays on time scales will follow.
- Finally, all the previously obtained results will be generalized in order to study the stability and synchronization of matrix-valued Hopfield and BAM neural networks with delays on time scales. The derived linear matrix inequalities can be easily solved by standard mathematics software. Numerical simulations of various examples will illustrate the effectiveness of the obtained theoretical results and their easiness of use for practical applications.

### Short description of the project

- Recurrent neural networks (RNNs) have many applications in classification, optimization, signal and image processing, pattern recognition, system identification, cryptography, and so on. These applications are highly dependent on the dynamical properties of the networks, making the analysis of the dynamical behavior an important part in the design of RNNs. Also, neural networks (NNs) were extended to hypercomplex domains, yielding hypercomplex-valued NNs, which have caught the attention of researchers in the past years, due to their increasing number of applications.
- Thus, the project aims at studying the stability and synchronization of quaternion, octonion, Clifford, and matrix-valued RNNs. Sufficient conditions given in terms of linear matrix inequalities for the stability and synchronization, using different control schemes, of quaternion-valued Hopfield and fractional-order (FO) NNs, of octonion-valued Hopfield and FO NNs, and of Clifford-valued Hopfield and FO NNs with neutral-type, leakage, time-varying, and distributed delays on time scales (TS) will be derived using techniques and methods extended from the real- and complex-valued domains.
- Finally, all the previously obtained results will be generalized to study the stability and synchronization of matrix-valued Hopfield and BAM NNs with delays on TS. Numerical simulations of various examples will illustrate the effectiveness of the obtained theoretical results and their easiness of use for practical applications.

### Implementation period

01.04.2022 – 31.03.2024

### Main activities

The main objectives of the research project are:

01. Stability and synchronization analysis of quaternion-valued Hopfield and fractional-order neural networks.
02. Stability and synchronization analysis of octonion-valued Hopfield and fractional-order neural networks.
03. Stability and synchronization analysis of Clifford-valued Hopfield and fractional-order neural networks.
04. Stability and synchronization analysis of matrix-valued Hopfield and BAM neural networks.
05. Dissemination of results and support of research activities.

### Results

The main theoretical impact will be the profound understanding of several qualitative properties of hypercomplex - valued recurrent neural networks with delays. The main practical impact of the anticipated contributions lies in the fact that they allow and facilitate the design of highly efficient neural networks that can be employed in many areas such as associative memories, pattern and image recognition, secure communication, cryptography, and so on. The implementation and analysis of state of the art neural network models may lead to major technological advances which have potential for great impact in the fields of communication and control engineering. The expected publications obtained in the framework of this project will give visibility to the research in this scientific area accomplished in Romania, and will increase the potential for external funding and international collaborations.

- Each of the activities in the project will be summarized in at least one journal or conference paper, representing the deliverables of that activity. Thus, the deliverables of the project will be a minimum of 5 journal papers and a minimum of 3 journal papers or conference papers.

### Applicability and transferability of the results

- The main theoretical impact will be the profound understanding of several qualitative properties of hypercomplex-valued recurrent neural networks with delays;
- The main practical impact of the contributions lies in the fact that they allow and facilitate the design of highly efficient neural networks that can be employed in many areas such as associative memories, pattern and image recognition, secure communication, cryptography, and soon;
- The implementation and analysis of state of the art neural network models may lead to major technological advances which have potential for great impact in the fields of communication and control engineering;
- The expected publications obtained in the framework of the project will give visibility to the research in this scientific area accomplished in Romania, and will increase the potential for external funding and international collaborations.

### Financed through/by

- Ministry of Research, Innovation and Digitalization,  
CNCS - UEFISCDI,  
Project number PN-III-P1-1.1-PD-2021-0345, within PNCDI III

### Research Center

Research Center for Computers and Information Technology

### Research Team

**Project leader:** Prof. Dr. Eng. Habil. Călin-Adrian POPA

**Mentor:** Prof. Dr. Eng. Radu-Emil PRECUP

### Contact information

Prof. Dr. Eng. Habil. Călin-Adrian POPA  
Faculty of Automation and Computers,  
Department of Computer and Information Technology  
Address: 2, Vasile Pârvan Blvd., 300223, Timisoara  
Phone: (+40) 256 404 061  
E-mail: calin-adrian.popa@upt.ro

## INTEGRATED CONCEPT FOR PLATINUM GROUP METALS RECOVERY BY ADSORPTION ONTO IONIC LIQUID-IMPREGNATED LAYERED DOUBLE HYDROXIDES AND FURTHER REUSE AS PHOTOCATALYST FOR WATER TREATMENT

### Goal of the project

The **goal** of the RE-ADPHOTOCAT project is to **recover** the platinum group metals (PGMs) by **adsorption** onto ionic liquid (ILs)-impregnated layered double hydroxides (LDHs) and further **reuse** as **photocatalyst** in the degradation process of undesirable compounds from wastewaters. The project is in line with the European Union vision for sustainable development, since a green solution is proposed for the recover of useful elements from aqueous solutions and the resulted spent adsorbent is further applied as photocatalyst in the degradation process of undesirable compounds from wastewaters, thus engaging both environmental and economic benefit.

### Short description of the project

The proposed project represents a promising route of PGMs recover followed by a perspective application as photocatalyst.

and photocatalytic activity of the spent adsorbent: choosing the life cycle for the most favorable material, from point of view of the synthesis economics and efficiency of PGMs, as well as unwanted compounds removal from water.

### Project implemented by

Politehnica University Timisoara  
Faculty of Industrial Chemistry and Environmental Engineering  
Department CAICAM

### Implementation period

March 2021 – February 2023

### Main activities

**A1.** Obtaining and characterization of ILs impregnated LDHs. Various ILs will be used (imidazolium, ammonium and phosphonium based ILs) which will be impregnated on various LDHs (M<sup>II</sup>/M<sup>III</sup> systems: Mg/Al; Zn/Al; Mg/Fe; Cu/Fe), using two methods of impregnations: ultrasonication followed by the drying under vacuum and co-synthesis. The structural and morphological characterization of the ILs impregnated LDH will be realized to decide the efficiency of the studied impregnation methods.

**A2.** Adsorption of PGMs from aqueous solutions onto ILs impregnated LDHs. The adsorption performance of the obtained adsorbent material will be optimized by studying the dependence of its adsorption capacity and PGMs elimination degree versus various parameters (i.e. nature of the used ILs and LDHs, aqueous solutions pH, solid:liquid ratio, etc.).

**A3.** Converting the spent adsorbents into photocatalysts for elimination of undesirable compounds from water. An optimal catalytic material will be elaborated, by correlations between the obtaining routes of ILs impregnated LDHs, adsorptive performance of the obtained material

### Results

The results will include, but are not limited to:

- Protocols for obtaining ILs-impregnated LDHs;
- Method for removal of PGMs from water by adsorption onto ILs impregnated LDHs;
- Protocol for water treatment containing undesirable compounds via reclaiming of spent adsorbent;
- 3 ISI papers published;
- Oral and poster presentation at scientific conferences;
- A book chapter published;
- 1 patent demand.

### Applicability and transferability of the results

- Good practice guide for a closed cycle technology regarding the PGMs recover and reuse.
- The research results will also be disseminated as conference presentations and articles in ISI publications to increase project visibility. The know-how achieved within the project development will also be used to coordinate a diploma paper, and a PhD thesis. The implementation team will apply for a patent request to protect the results obtained within the project for future transfer to the industry.

## Financed through/by

This work was supported by a grant of the Romanian Ministry of Education and Research, CNCS - UEFISCDI, project number PN-III-P1-1.1-TE-2019-1555, within PNCDI III

## Research Center

- Research Center for Environmental Science and Engineering
- Research Institute for Renewable Energy

## Research Team

- Assoc. Prof. Dr. Eng. Lavinia LUPA – project leader
- Lecturer Dr. Eng. Laura COCHECI
- Assoc. Prof. Dr. Eng. Radu LAZAU
- Ph. D. Student Eng. Samuel Nick TOLEA
- M.Sc. Student Eng. Ionut BAILESCU

## Contact information

Assoc. Prof. Dr. Eng. Lavinia LUPA  
Faculty of Industrial Chemistry and Environmental Engineering  
Department of Applied Chemistry and Engineering of Inorganic  
Compounds and Environment  
Address: 6, Vasile Pärvan Blvd., 300223, Timișoara  
Phone: (+40) 256 403 059  
Mobile: (+40)762 236 301  
E-mail: [lavinia.lupa@upt.ro](mailto:lavinia.lupa@upt.ro)  
Project Website:  
[http://www.upt.ro/Informatii\\_UPT\\_1874\\_ro.html](http://www.upt.ro/Informatii_UPT_1874_ro.html)

## IMPROVED TECHNOLOGIES FOR THE DEVELOPMENT OF ELECTROSPUN POLYSULFONE MEMBRANES INTEGRATED IN AN EXTRACORPOREAL DEVICE APPLICABLE IN RENAL FAILURE

### Goal of the project

The goal of the project is to catalyze the fundamental redesign of dialysis, supported by a series of innovations in biomaterials field used for hemodialysis and to develop a novel technology able to overcome the disadvantages of conventional dialysis technologies and to offer numerous advantages. The project aims to design and develop new bioactive functionalized hollow membranes - fibrous functionalized bioactive membranes based on quaternized polysulfones - with improved characteristics (modeled and controlled morphology, biocompatibility, hydrophilic/hydrophobic balance), which will be used as medium separations in an extracorporeal innovative device.

### Short description of the project

We aim to develop new bioactive functionalized hollow membranes (FHMs) which will be used as medium separations, considering the competitive or selective adsorption of the biological materials, in an extracorporeal innovative device (EID), which will be tested and validated by establishing their efficiency in advanced hemodialysis (HD) treatment.

### Project implemented by

- "Petru Poni" Institute of Macromolecular Chemistry Iasi (ICMPP) – project **coordinator**
- Politehnica University Timisoara, Faculty of Industrial Chemistry and Environmental Engineering (UPT) – project partner

### Implementation period

28.06.2022-30.06.2024

### Main activities

- Formulation and design of functionalized hollow biocompatible membranes based on quaternized polysulfones (FHMs)
- Optimization of surface properties in order to obtain FHMs applicable in the dialysis process.
- Design and development of an extracorporeal innovative device (EID) by integrating the optimized experimental demonstrator (FHMs) into a final product.
- Evaluation of FHMs membranes functionality for medical applications.
- Validation of the laboratory technology through specific tests.
- Dissemination of the results.

### Results

Various hollow biocompatible membranes based on quaternized polysulfones functionalized with antioxidants/anticoagulants (FHMs) with desired properties for applications in biomedicine, will be obtained.

Will be designed and developed an extracorporeal innovative device (EID), which together with the tested membranes (FHMs) will fulfill the following requirements: present a small and compact design, allow high blood flow rates, prevent clotting, permits the easy replace of the membrane and an easy cleaning and sterilization processes.

### Applicability and transferability of the results

- A solid transfer of knowledge occurs during the collaboration between the partners involved in the research.
- Application of the developed membranes in an extracorporeal innovative device (EID), increasing competitiveness in research-development-innovation and technology transfer by introduction to new innovative materials integrated in a circuit with application in HD therapy.

## Financed through/by

This work was supported by a grant of the Romanian Ministry of Education and Research, CCCDI - UEFISCDI, project number PN-III-P2-2.1-PED-2021-2700, within PNCDI III

## Research Center

- Research Center for Environmental Science and Engineering
- Research Institute for Renewable Energy

## Research Team

- (ICMPP) – project coordinator:
  - Dr. Anca FILIMON – **project director**
  - Dr. Adina Maria DOBOS
  - Dr. Irina ROSCA
  - Dr. Dragos PEPTANARIU
  - Dr. Alexandra BARGAN
  - Dr. Mihaela Dorina ONOFREI
  - Ph.D. Student Oana DUMBRAVA
- 
- (UPT) – project partner:
  - Assoc. Prof. Dr. Eng. Lavinia LUPA – **project responsible**
  - Prof. Dr. Eng. Petru NEGREA
  - Ph.D. Student Eng. Ioan-Bogdan PASCU

## Contact information

Assoc. Prof. Dr. Eng. Lavinia LUPA  
Faculty of Industrial Chemistry and Environmental Engineering  
Department of Applied Chemistry and Engineering of Inorganic Compounds and Environment  
Address: 6, Vasile Pârvan Blvd., 300223, Timișoara  
Phone: (+40) 256 403 059  
Mobile: (+40) 762 236 301  
E-mail: [lavinia.lupa@upt.ro](mailto:lavinia.lupa@upt.ro)  
Project Website: <https://icmpp.ro/techmembreid>

## SUSTAINABLE ROUTES FOR CARBOHYDRATE-BASED BIOSURFACTANTS IN GREEN REACTION MEDIA (GREENBIOSURF)

### Goal of the project

The key objective of the project is to develop an innovative and sustainable process and solvent system for the synthesis of new sugar ester biosurfactants.

Specific objectives are:

- (i) design and optimization of the biocatalytic synthesis of sugar ester in green solvent systems (NADES), to determine the optimal solvent composition, reaction conditions, enzyme recovery possibilities and downstream processing parameters and
- (ii) synthesis and characterization of at least three different novel carbohydrate biosurfactants.

### Short description of the project

The project develops an innovative and sustainable biocatalytic process for the production of sugar fatty acid esters (SFAEs), an important class of green biosurfactants.

SFAEs have excellent emulsifying properties and foaming ability, and can be used in food ingredients, in cosmetics, detergents, pharmaceuticals and in agrochemicals.

The aim of this project is to develop and optimise efficient biocatalysts and solvent systems for the synthesis of SFAEs (Fig.1). For this reason, the biocatalytic synthesis of novel SFAEs will be carried out in natural deep eutectic solvents (NADES) and the optimal solvent composition, reaction conditions, enzyme recovery possibilities and downstream processing will be determined. Selectivity and operational stability of different lipases in NADES will be evaluated.

*The stabilization of the selected enzymes will be improved by immobilization, including covalent binding on synthetic resins and sol-gel entrapment.* The reaction engineering will target the effect of NADES composition and process parameters.

SFAEs will be prepared at preparative scale, at optimal process conditions. The biobased carbohydrate-based surfactants will be characterized in detail by appropriate analytical techniques for structure confirmation, assessment of the physico-chemical and surfactant properties, in view of possible applications in food and other sectors.

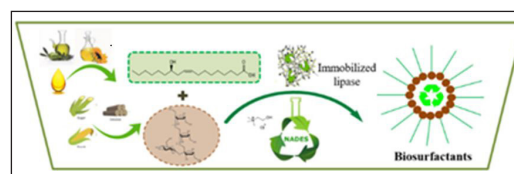

Fig. 1. Enzymatic biotransformations of fatty acids and sugars into biosurfactants

### Project implemented by

Politehnica University Timisoara

### Implementation period

15.02.2021 – 14.02.2024

### Main activities

**Phase 3/2023: Characterization of the synthesized biosurfactants and evaluation of the surface-active properties.**

**Activity 3.1.** Enzymatic synthesis of esters of mono- and oligosaccharides by esterification with fatty acids and fatty acid alkyl esters.

**Activity 3.2.** Reaction engineering and understanding the effect of process parameters on the bioesters composition.

**Activity 3.3.** Structural and physical-chemical characterization of the synthesized products.

**Activity 3.4.** Investigation of tensioactive properties of esters of carbohydrates.

**Activity 3.5.** Testing the foaming and emulsifying properties of carbohydrate esters.

**Activity 3.6.** Dissemination of results.

## Results

### Main scientific achievements of Phase 3:

- Esters of fatty acids with glucose, sucrose and inulin were obtained by lipase-catalyzed esterification in specially designed reactive NADES.
- Reaction engineering with design of experiments (DOE) identified optimal conditions for carbohydrate esterification and enhanced reaction yield and selectivity.
- The structure and physical chemical properties of all new compounds obtained were determined with advanced methods.
- Fatty acid esters of polyols and carbohydrates are surface agents for stabilizing water/oil and oil/water emulsions, respectively. Fatty acid esters of carbohydrates are good foaming agents.
- Results were presented at international conferences and one paper was published in an ISI journal.

### Dissemination. Selected publications and presentations:

1. A.R. Buzatu, M.A. Soler, S. Fortuna, O. Ozkinlic, D.M. Dreava, I. Bîtcă, V. Badea, P. Giannozzi, F. Fogolari, L. Gardossi, F. Peter, A. Todea, **C.G. Boeriu**. Reactive natural deep eutectic solvents as essential reaction media for lipase catalyzed esterification of carbohydrate polyols. *Catalysis Today* 426, 2024, 114373.

2. I. Bîtcă, A. Petrovici, A. Pellis, S. Klebert, Z. Karoly, L. Bereczki, F. Peter, A. Todea. Enzymatic route for selective glycerol; oxidation using covalently immobilized laccases. *Enzyme and Microbial Technology*, 163, 2023, 110168.

3. A.R. Buzatu, A. Todea, F. Peter, **C.G. Boeriu**. The role of reactive natural deep eutectic solvents in sustainable biocatalysis. *ChemCatChem*, submitted, under review.

4. A.R. Buzatu, D.M. Dreavă, V. Badea, A. Todea, F. Peter, **C.G. Boeriu**. Effective lipase catalyzed synthesis of lauryl esters of carbohydrate polyols in reactive natural deep eutectic solvents. 19<sup>th</sup> International Conference of Renewable Resources and Biorefineries (RRB), Riga, Latvia, 31 May-2 June 2023, Oral presentation.

5. F. Peter, A.R. Buzatu, A. Todea, D.M. Dreavă, V. Badea, **C.G. Boeriu**. Efficient lipase catalyzed esterification of carbohydrate polyols in reactive natural deep eutectic solvents. 16<sup>th</sup> International Symposium on Biocatalysis & Biotransformations (BIOTRANS), La Rochelle, France, 25-29 June 2023, Poster.

6. **C.G. Boeriu**, A.R. Buzatu, A. Todea, D.M. Dreavă, I. Bîtcă, F. Peter. Efficient lipase catalyzed synthesis of biosurfactants in reactive natural deep eutectic solvents. 6<sup>th</sup> EuChemS Conference on Green and Sustainable Chemistry (EuGSC), Salerno, Italy, 3-6 September 2023, Oral presentation.

## Financed through/by

Romanian Ministry of Education and Research, CCCDI - UEFISCDI, Project code: PN-III-P4-ID-PCE-2020-2177, within PNCDI III

## Research Center

Research Center for Organic, Macromolecular and Natural Compounds' Chemistry and Engineering

## Research Team

### Project leader

- Prof. Dr. Eng. Carmen Gabriela BOERIU

### Researchers

- Prof. Dr. Eng. Francisc PETER
- Lecturer Dr. Eng. Alina Ramona BUZATU
- Lecturer Dr. Eng. Cristina PAUL
- Lecturer Dr. Eng. Iulia Maria PĂUȘESCU
- Lecturer Dr. Chem. Diana Maria DREAVĂ
- Lecturer Dr. Eng. Valentin BADEA
- Ph.D. Student Eng. Ioan BÎTCAN

## Contact information

Prof. Dr. Eng. Carmen Gabriela BOERIU  
Faculty of Industrial Chemistry and Environmental Engineering,  
Department of Applied Chemistry and Engineering of Organic and  
Natural Compounds  
6 Carol Telbisz street, 300001, Timisoara  
Phone: (+40) 256 404216  
E-mail: carmengabriela.boeriu@upt.ro  
Project Website:

<https://chim.upt.ro/ro/cercetare/proiecte-de-cercetare/314-pn-iii-p4-id-pce-2020-2177>



## INDUSTRIAL PROTOTYPE FOR STRUCTURAL SYSTEMS MADE OF COLD-FORMED STEEL BEAMS WITH CORRUGATED WEBS ASSEMBLED WITH WELDING TECHNOLOGIES OF HIGH PRODUCTIVITY (WELLFORMED-FRAME)

### Goal of the project

The purpose of the project is the testing, evaluation and validation of a structural system for single-storey industrial buildings made of cold-formed steel beams with corrugated webs. The technical solution will be raised to the technological level TRL 6, which will be introduced on the commercial market.



Single-storey industrial buildings made of cold-formed steel beams with corrugated webs

### Short description of the project

The project includes an experimental campaign, extended by numerical simulations, with the purpose of characterization and optimization of connection joints and a real-scale prototype under real operational conditions.

### Project implemented by

- ANOTECH STEELWORKS S.R.L., Romania
- Politehnica University Timisoara, Romania

### Implementation period

30.06.2022-30.06.2024

### Main activities

- Design of the experimental program;
- Experimental tests on materials and joints;
- Numerical investigations of joints;
- Experimental tests on full-scale industrial frames;
- Numerical studies on structural systems made of cold-formed steel beams with corrugated web;
- Guidelines for manufacture and design;
- Dissemination of results.

### Results

1. Guidelines for the design of structural systems made of cold-formed steel beams with corrugated web;
2. Tables for bearing capacities of joints and standardized frames composed of cold-formed steel beams with corrugated web;
3. Guidelines for the fabrication of structural systems made of cold-formed steel beams with corrugated web;
4. A prototype of structural system with cold-formed steel beams, with corrugated web and assembled using high productivity welding technologies, upgraded to TRL6, compared to the current TRL4 model.

### Applicability and transferability of the results

- Based on the results of the experimental campaign, a technical report will be produced with recommendations on the manufacture of structural systems made of cold-formed steel beams with corrugated webs.
- A guide with recommendations on the design and modelling of structural systems made of cold-formed steel beams with corrugated webs, together with capacity tables for different spans and loads, will be available.

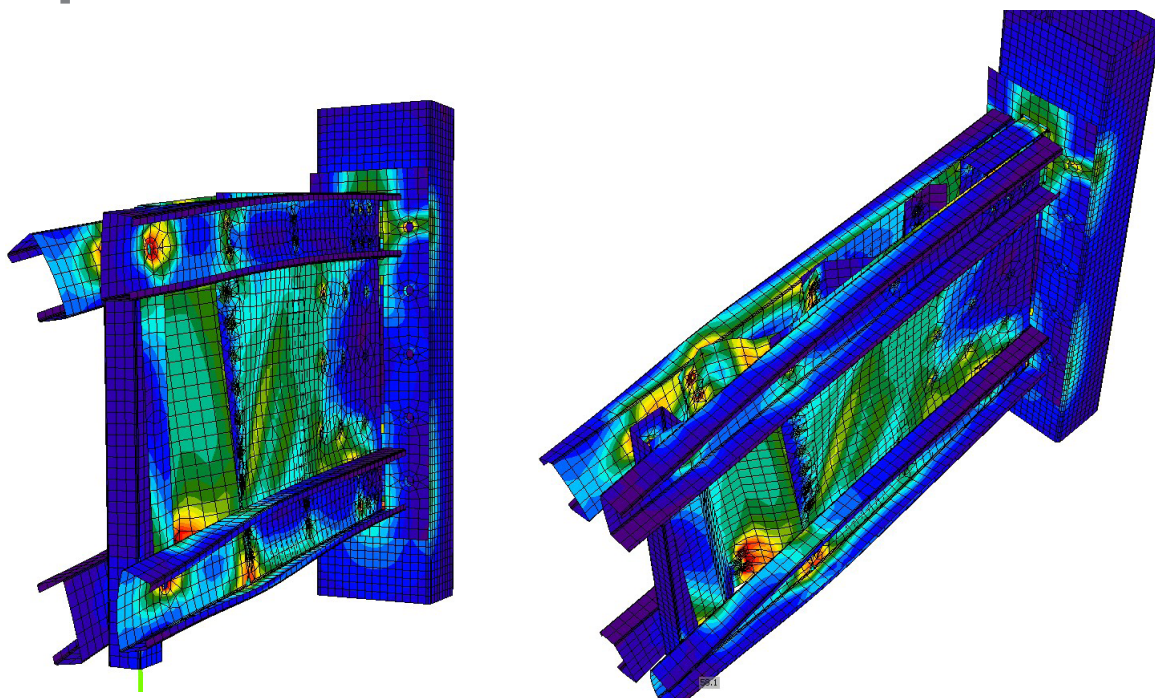

Numerical investigations of joints

## Financed through/by

This work was supported by a grant of the Ministry of Research, Innovation and Digitization, CCCDI - UEFISCDI, project number PN-III-P2-2.1-PTE-2021-0237, within PNCDI III”.

## Research Center

- Research Center for Mechanics of Materials and Structural Safety (CEMSIG), Politehnica University Timisoara

## Research Team

- Prof. Dr. Eng. Viorel UNGUREANU
- Prof. Dr. Eng. Florea DINU
- Lecturer Dr. Eng. Ioan BOTH
- Lecturer Dr. Eng. Mircea BURCĂ
- Ph.D. Student Eng. Andrei GÎRBACEA
- PhD Student Eng. Florin BODEA

## Contact information

Prof. Dr. Eng. Viorel UNGUREANU  
Faculty of Civil Engineering  
Department of Steel Structures and Structural Mechanics  
Address: 1 Ioan Curea street, 300224, Timișoara  
Phone: (+40) 256 403912  
Mobile: (+40) 740 137640  
E-mail: viorel.ungureanu@upt.ro

## OPTIMISATION AND VALIDATION OF A SPECIALISED SOFTWARE USED FOR CALCULATING THE THERMAL PERFORMANCE OF THE BUILDING ENVELOPE COMPONENTS, DEVELOPED BASED ON AERIAL AND TERRESTRIAL THERMOGRAPHY METHOD

### Goal of the project

The primary goal of the project is to develop and provide a calculation methodology and software for use in both the technical expertise and thermal rehabilitation of existing buildings, encompassing structural and energy expertise. Additionally, the project aims to facilitate the evaluation of the energy performance of newly constructed buildings prior to the reception phase. Furthermore, the project acknowledges the imperative to provide training for the workforce, equipping them with the requisite skills to serve as specialists capable of contributing to the creation of buildings with nearly zero energy consumption and emissions.

### Short description of the project

In the development phase of the energy audit documentation, a significant volume of calculations is generated when evaluating the thermal performance of the building envelope elements. This project introduces a methodology and software which uses aerial and terrestrial thermography methods to assess the thermal performance of the building envelope under actual operating conditions. The proposed methodology significantly reduces the duration of the auditing activity and provides results based on the real behavior of the building. The project includes the study of several case study buildings, among which five buildings are in Timișoara.

### Project implemented by

Coordinator: Technical University of Cluj-Napoca

Partners:

Politehnica University Timisoara

Technical University of Civil Engineering of Bucharest

Technical University Gheorghe Asachi of Iasi

### Implementation period

July 2022 – June 2024

### Main activities

The project activities are structured in three main phases. Phase two (2023) includes the following main activities:

- terrestrial and aerial thermography, and measurements of exterior and interior climatic parameters for identified case study buildings.
- formulation and development of the calculation methodology for vertical and horizontal construction elements.
- modeling and numerical simulation of envelope elements for the investigated buildings.

### Results

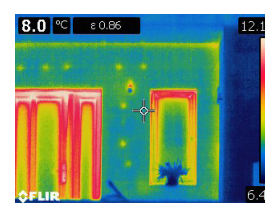
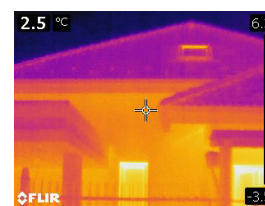
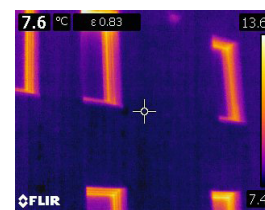

## Applicability and transferability of the results

The methodology under development in this project can play an important role in substantially reducing the time required for conducting building audits. Moreover, it enables the possibility to obtain results based on the actual behavior of buildings. This streamlined approach ensures a more accurate and practical assessment of the building's performance, enhancing the overall effectiveness of the energy audit process.

## Financed through/by

This work was supported by a grant of the Ministry of Research, Innovation and Digitization, CCCDI - UEFISCDI, project number PN-III-P2-2.1-PED-2021-4137, within PNCDI III - CT 714PED / 2022.

## Research Center

Research Center for the Rehabilitation of Buildings

## Research Team

### Project leader:

- Prof. Dr. Eng. Daniel DAN

### Researcher:

- Assist. Prof. Dr. Eng. Cristina MARINCU

## Contact information

Prof. Dr. Eng. Daniel DAN  
Faculty of Civil Engineering  
Department of Civil Engineering and Building Services  
Address: 2/A Traian Lalescu street, 300223, Timisoara  
Phone: (+40) 256 403 934  
E-mail: daniel.dan@upt.ro  
Web: <https://www.thermogproject.com/home>

## SMART DEVICE FOR AVOIDING PARALLEL RESONANCES TO THE SWITCHING OF CAPACITIVE COMPENSATORS IN UNBALANCED AND HARMONIC POLLUTED THREE-PHASE NETWORKS

### Goal of the project

Capacitor banks switching to the network leads to the resonance phenomena, which, along with harmonic current flow having frequencies near the resonance frequency, causes high values of the voltage across the capacitors and respectively high values of the currents flowing through the capacitor banks. The overvoltages lead to insulation overstressing and the high values of currents produce a capacitor heating. **The goal of the project is:** *developing and testing a smart device for avoiding the resonances to the switching of capacitive compensators in unbalanced and harmonic polluted three-phase networks.*

### Short description of the project

Within the project is developed and tested an experimental model for avoiding the resonances to the switching of capacitive compensators in unbalanced and harmonic polluted three-phase networks.

### Project implemented by

- Coordinator: Politehnica University Timișoara
- Partners:
  - P1: Technical University of Cluj-Napoca;
  - P2: ICPE S.A.

### Implementation period

27.06.2022 – 27.06.2024

### Main activities

- The activities carried out for the effective realization of the project are industrial research and experimental development, which include all the stages to be completed, from the mathematical model and the study by modeling-simulation, to the design, execution, and release of the experimental model.
- The first stage of the project includes activities related to modeling and simulation of experimental model operation regimes, design of primary and control-command circuits for the experimental model, design of monitoring circuits and process analysis, respectively design of the mechanical structure of the experimental model.
- The second stage refers to software development activities (creation of virtual instruments) and implementation on the intelligent device, respectively the physical realization of the experimental model.
- The third stage contains testing and optimization activities.

### Results

- Within Stage II of project implementation, the LabVIEW graphical programming language was used for virtual instrumental development for controlling the different steps of the capacitor banks. Also, the algorithm determines in advance the possible amplifications of the harmonic regime caused by the occurrence of resonances. Since the NI technology proposed for implementing the algorithm has appropriate hardware equipment, in addition to the command and control circuits, virtual instruments were also developed for process monitoring and analysis.
- The chosen hardware solution uses a USB CompactDAQ chassis (CDAQ-9178), designed for measurement and control systems with portable sensors. The chassis offers the plug-and-play simplicity of USB when measuring electrical quantities. This chassis is used with a combination of C-series I/O modules to create a combination of analog and digital I/O measurements.



## Applicability and transferability of the results

- Laboratory tests will be done to validate the proposed technology. The test results will be included in the reports as part of the deliverables of this project, presenting the operating conditions and the accuracy of the obtained results in comparison to the estimated ones. The solution proposed by the project will be subject of a patent application.
- The P2 partner, ICPE S.A., is interested in the further development of this experimental model and the creation of a prototype to implement the solution proposed within the project.

## Financed through/by

- UEFISCDI, Contract number: 703PED/21.06.2022,
- Project code: PN-III-P2-2.1-PED-2021-4309

## Research Center

- Research Center for Power Systems Analysis and Optimization

## Research Team

### Project leader:

- Assoc. Prof. Dr. Eng. Alexandru BĂLOI

### Researchers:

- Prof. Dr. Eng. Adrian PANĂ
- Assoc. Prof. Dr. Eng. Florin MOLNAR-MATEI
- Lecturer Dr. Eng. Ilona BUCATARIU
- Assoc. Prof. Dr. Eng. Attila SIMO
- Lecturer Dr. Eng. Felicia BĂLOI
- Lecturer Dr. Eng. Nicolae CHIOSA
- Ph.D. Student Eng. Cristian STĂNESE

## Contact information

Assoc. Prof. Dr. Eng. Alexandru BĂLOI  
Faculty of Electrical and Power Engineering  
Department of Power Engineering  
Address: Bd. Vasile Pârvan, No. 2, 300223, Timisoara  
Phone: (+40) 256 403 428  
Mobile: (+40) 742 527 442  
E-mail: alexandru.baloi@upt.ro  
Project Website:  
<https://sites.google.com/view/smart-q-switching>

## IMPLEMENTATION OF CMOS MULTIPLEXERS IN A WATER QUALITY CONTROL STATION FOR COST REDUCTION IN RECIRCULATING AQUACULTURE (RASCONTROL)

### Goal of the project

- Implementation of CMOS multiplexers in measurement, control and correction automatic systems of water quality in aquaculture, aiming to reduce equipment costs to make it accessible to smaller RAS farms.

### Short description of the project

- The RASCONTROL project advances a new eco-technology for monitoring the aqueous environment, from the laboratory level to the industrial level, which will also include corrective intervention of water chemistry.
- This equipment will be able to be used in intensive aquaculture and by reducing costs and simplifying the setting, it will also allow small and medium-sized RAS farms to sustainably automate their water quality management.

### Project implemented by

**Coordinator:** DFR Systems SRL

**Partners:**

- P1: University of Craiova, Romania;
- P2: University Politehnica Timisoara. Romania.

### Implementation period

23.06.2022 - 22.06.2024

### Main activities

- Experimental model design;
- Realization of experimental model;
- Testing the experimental model in laboratory conditions;
- Designing a pilot system to work in a RAS monitoring system;
- Realization of pilot plant - integrated system;
- Pilot testing in situ conditions (mounting in a RAS system);
- Elaboration of manual for presentation and use of the system;
- Dissemination of results.

### Results

- A. Expanding the capabilities of the SPEAR instrument for more electrode types and for driving water composition and circulation correction equipment;
- B. Upgrading the SPEAR-64-8-8 switch/multiplexer into a masterboard switch/multiplexer, capable of managing up to 8 multielectrode probes (i.e. central observation nodes with measuring cells);
- C. Development of the station's central monitoring and control unit (with computer and microcontrollers);
- D. Upgrading the software used by SPEAR to the new architecture and new features;
- E. Interfacing monitoring equipment with standard water property correction equipment (pumps, valves, activation of chemical filters, adjustment of nitrification activity and pH control);
- F. Production of a user manual and training materials.
- G. In 2023:
  - i. Within the Politehnica University of Timisoara, a new laboratory was built, with equipment and experimental installation for recirculating aquaculture systems. "Laboratory for the testing and control of water quality in RAS" realized within the project includes all the electrical and water supply and sewage infrastructure necessary for the operation of the pilot station. It consists of two parts:
    - a. the analysis and control part;
    - b. The pilot station consisting of two identical RAS installations designed to operate in parallel.

ii. Published article: **Vasile Daniel GHERMAN**, Vily Marius CIMPOIASU, Ioana Corina MOGA, Radu POPA, Conservation of Aquatic Ecosystems by Constraining Nitrogen Pollution Through Aquaculture Effluents, International Journal of Conservation Science Volume 14, Issue 3, July-September 2023: pg, 1107- 1126, ISSN: 2067-533X, DOI: [10.36868/IJCS.2023.03.21](https://doi.org/10.36868/IJCS.2023.03.21).

iii. Awards obtained:

1. Gold medal at the UGAL INVENT Innovation and Research Fair, November 9-10, 2023;
2. Diploma of excellence from INMA during the Innovation and Research Salon UGAL INVENT, November 9-10, 2023;
3. Special award given by CITT, during the Innovation and Research Salon UGAL INVENT, November 9-10, 2023;
4. Gold medal at the 15<sup>th</sup> European Exhibition of Creativity and Innovation – EUROINVENT, Iasi, Romania, May 11-13, 2023

### Applicability and transferability of the results

- The RASCONTROL project upgrades a recently developed technology that substantially reduces the cost of electrochemical water monitoring and makes it compatible with RAS units;
- Unlike other similar techniques where the number of electrodes is small compared to the number of measuring devices, SPEAR technology selects electrodes electronically by software commands;
- In this way it is possible for a single meter to scan electrodes positioned at many reading points and to operate with many types of electrodes;
- The basic piece of this equipment is a channel selector (multiplexer switch). Although multiplexers have already been developed in the industry, quality multiplexers are very expensive (around \$2000). In contrast, SPEAR channel changers are purpose-built, with multi-electrode control, and are produced by RASCONTROL participants for less than \$100 a piece.

### Financed through/by

UEFISCDI

### Research Center

Research Center for Hydrotechnics

### Research Team

#### Project leader in UPT:

- Lecturer Dr. Biol. Vasile GHERMAN

#### Researchers:

- Prof. Dr. Eng. Petru NEGREA ,

- Assoc. Prof. Dr. Eng. Narcis DUTEANU

### Contact information

Lecturer Dr. Biol. Vasile GHERMAN

Faculty of Civil Engineering,

Department of Hydrotechnics

Address: No. 1/A, Spl. Spiru Haret Street, 300023, Timisoara

Phone: (+40) 256 404118

E-mail: [vasile.gherman@upt.ro](mailto:vasile.gherman@upt.ro)

Project Website:

<https://fluensys.ro/cercetare/proiecte/rascontrol/>



## EXPERTISE IN UNDERGROUND SULFIDIC HABITATS

### Goal of the project:

The general objective of the mobility project is the initiation of collaboration between the **Microbiological Analysis Laboratory and Microbiological Risk Management** coordinated by Lecturer Dr. Biol. Gherman Vasile Daniel and the lab of Dr. Serban M. Sarbu, California State University, Chico, California (expertise in subsurface sulfidic habitats).

### Short description of the project

In this project:

- Dr. Serban M. Sarbu presented modern technologies for the inventory and study of biodiversity from extreme subterranean environments and biodiversity hotspots.
- Isolation of microorganisms and sequencing to determine biodiversity from samples collected from different extreme sulfidic environments in Romania, Greece, Albania and Italy.
- Carrying out biodiversity assessments in some of the most interesting extreme life environments where the primary production of organic matter is ensured by chemosynthesis processes.
- Dr. Serban M. Sarbu has a special background in the study of these living environments, being part of the team that discovered **Mobile Cave in Mangalia** in 1986, **the first sulfidic ecosystem discovered on Planet Earth** that is based on primary production of organic matter originating exclusively from chemosynthesis and independent of sunlight.
- Over the years, Dr. Serban M. Sarbu has been involved in the study of the majority of underground sulphide environments described in several countries.
- **The Microbiological Analysis and Microbiological Risk Management Laboratory** coordinated by Lecturer Dr. Biol. Gherman Vasile Daniel has worked for the last 10 years in the study of extreme living environments together with teams of researchers from France, Belgium and the Netherlands, together with whom he published more than 10 scientific papers, one of which in 2022 in the prestigious Scientific Journal: Nature Microbiology.
- Dr. Serban M. Sarbu was also part of the research team.

### Project implemented by

#### Coordinator:

- Politehnica University Timisoara

#### Partner:

- California State University, Chico, California

### Implementation period

- 30.10.2023 – 03.11.2023

### Main activities

**Day 1:** Presentation meetings with researchers, doctoral and master's students from the Faculty of Industrial Chemistry and Environmental Engineering, Politehnica University Timisoara. (1 hour)

- Working meeting with Dr. Gherman Vasile Daniel and the research team - ideas for continuing collaboration on classical methods of studying biodiversity (eg taxonomy) and expanding collaboration on molecular phylogeny, stable isotopes and genomics will be discussed.

**Day 2:** Scientific conference within the Faculty of Industrial Chemistry and Environmental Engineering; thematic: Extreme life environments - sulfidic environments - primary production of organic matter through chemosynthesis (1 hour)  
Meetings with professors and researchers from the Faculty of Industrial Chemistry and Environmental Engineering, Politehnica University Timisoara (1 hour)

- Working meeting with the research team - a field visit will be made in the Pischia area for the evaluation of some mineral springs and the collection of samples for molecular and isotopic analysis.

**Day 3:** Intensive course on the ecology of sulfidic environments, isotopic methods for analysing the flow of organic matter in microbial ecosystems, methods for isolating genetic material and sequencing (4 hours) for approximately 15 teachers, researchers and students.  
Practical applications in the laboratory (2 hours).

- Working meeting with the research team: innovative, interdisciplinary technologies will be developed and tested in the preparation of biological samples from the field.

**Day 4:** Intensive course on the ecology of sulfidic environments, isotopic analysis methods, genetic material isolation and sequencing methods (4 hours) for approximately 15 teaching staff, researchers and students.

- Practical applications in the laboratory (2 hours).
- Working meeting with the research team: innovative, interdisciplinary technologies will be developed and tested in the preparation of biological samples from the field.

**Day 5** Final working meeting with Lecturer Dr. Biol. Gherman Vasile and the research team – analysis and discussions regarding the preliminary results obtained; a long-term collaboration plan between the 2 laboratories will be developed.

- Meetings with professors and researchers from the Faculty of Industrial Chemistry and Environmental Engineering, Politehnica University Timisoara.

## Results:

- The main results are:

- Conclusion of a collaboration agreement between the Politehnica University Timisoara and California State University, Chico.

- Preparation of **100 biological samples** to be sequenced at the laboratory at California State University, Chico.

- Training with students and researchers in isotope labelling techniques and analysis of extreme living environments.

- Evaluation of the possibilities for the Microbiological Analysis and Microbiological Risk Management Laboratory to develop in order to analyse the most diverse samples from sulfidic environments.

- Planning the future directions of collaboration and identifying sources of funding, both for equipment and for the continuation of researcher exchanges between the two laboratories.

## Applicability and transferability of the results

- The development of new protocols for the study of sulfidic living environments, new methods of analysis being established, identifying chemical and microbiological methods by which we can characterize such ecosystems.

- The new protocols will allow biodiversity assessments in some of the most interesting extreme life environments where the primary production of organic matter is ensured by chemosynthesis processes

## Financed through/by

- UEFISCDI

## Research Center

- Research Center for Hydrotechnics

## Research Team

### Project leader:

- Lecturer Dr. Biol. Vasile GHERMAN

### Researchers:

- Prof. Dr. Biol. Serban Mircea SARBU

## Contact information

Lecturer Dr. Biol. Vasile GHERMAN

Faculty of Civil Engineering,

Department of Hydrotechnics

Address: No. 1/A, Spl. Spiru Haret Street, 300023, Timisoara

Phone: (+40) 256 404118

E-mail: vasile.gherman@upt.ro

## INCREASING THE PERFORMANCE OF THE POLITEHNICA UNIVERSITY TIMISOARA BY CONSOLIDATING THE RESEARCH-DEVELOPMENT AND TECHNOLOGY TRANSFER CAPACITY IN THE FIELD "ENERGY, ENVIRONMENT AND CLIMATE CHANGE" AT THE BEGINNING OF ITS SECOND CENTURY OF EXISTENCE - PERFORM-CDI@UPT<sup>100</sup>

### Goal of the project

General objective of the project: **Increasing the institutional performance of the Politehnica University Timisoara**, by developing the research-development and knowledge transfer capacity of the Research Institute for Renewable Energy - ICER, UPT facility, by expanding and consolidating activities in the field of the smart specialization "**Energy, environment and climate change**" in order to serve the innovation requirements of economic operators in the Western Region of Romania in the context of the transition to a circular economy, respectively by intensifying collaborations and improving competitiveness and visibility at national and international level.

The general objective of the project is closely correlated with the objectives of **Sub-Program 1.2 – Institutional performance, Program 1 - Development of the national research and development system, National Research-Development and Innovation Plan for the period 2015-2020 (PNCDI III)**.

- The **specific objective 1** is focused on expanding and strengthening the research infrastructure in the field of "**Energy, environment and climate change**" by adding the **Research Center for Environmental Science and Engineering** to the multidisciplinary research platform developed by the PERFORM-TECH-UPT project (10PFE/16.10.2018), carried out in 2018–2020 and financed by the competition Institutional Development Projects for financing excellence in RDI.
- **Specific objective 2.** Development of mechanisms to ensure the increase of the capacity of the **Politehnica University Timisoara** to disseminate and capitalize on the knowledge and results obtained from RDI activities, which will increase both the visibility of the university internationally, as well as its competitiveness by involvement in research projects with national and European funding.
- **Specific objective 3.** Increasing the quality of research services offered and diversifying the provision of research, development and technology transfer services of UPT towards the economic environment and public administration entities, a continuous to adaptation to the innovation needs of economic operators, especially those in the Western Region of Romania. The professional and innovative potential of UPT specialists will be capitalized on, by stimulating collaborations between the university and the economic environment in order to strengthen the UPT position as its strategic partner.

### Short description of the project

The **PERFORM-TECH-UPT** project is dedicated to the institutional development of UPT through targeted activities on human resources, research and development infrastructure and international visibility.

### Project implemented by

Coordinator:  
Politehnica University Timisoara

### Implementation period

January 2022 – June 2024 (26 months)

### Main activities

- Project management and coordination
- Acquisition of significant R&D equipment and services
- Financial support for attending prestigious international conferences
- Stimulating the publication of articles in WOS indexed journal, located in the Q1
- Stimulating the doctoral research activity of the final year of internship for the successful completion of the experimental part of the thesis
- Identifying funding opportunities for research and the development of successful applications
- Development of a portfolio of new products / technologies / methods / systems / services, or significant improvement thereof
- Financial support for the mobility of 3 doctoral students in training stages
- Organizing a meeting with experts of the European commission and of the **National Contact Point**
- Integration and testing of purchased equipment within research centers / laboratories

## Results

- Efficient management of the project – preparation of a scientific and technical report on the implementation of the project, as well as of the specific financial documents;
- **Improvement of RDI infrastructure through the acquisition of significant equipment.**
  - Funding was provided for the publication in **Open Access** regime of scientific papers in WoS – Clarivate indexed journals, located in the first 2 quartiles;
  - There were supported financially: participation in 2 prestigious international conferences abroad, at 2 international conferences organized in the country, at an international inventions exhibition as well as participation in the **European Researchers' Night** event;
  - Participations were supported financially in prestigious international conferences abroad, international conferences organized in the country, and in national and international invention exhibitions;
  - A meeting was organized with two experts from **National Contact Point**, an entity from **UEFISCDI**. The ways in which the university scientific community will be able to access information on European funding instruments available in 2023 have been addressed and it was established for the end of November 2022 a direct on-site meeting at the university, with NCP experts that were to convey to the academic staff within UPT the particularities of open programs / calls, but also examples of good practice.

## Research Center

Within the Research Institute for Renewable Energy – ICER the following Research Centers were brought together:

1. Research Center for Materials Mechanics and Structural Safety (CEMSIG);
2. Research Center for the Processing and Characterization of Advanced Materials (CCPCMA);
3. Research Center for Smart Energy Conversion and Storage;
4. "Ștefan Nădașan" Research Laboratory for Strength, Integrity and Durability of Materials, Structures and Conductors;
5. Research Center for Environmental Science and Engineering

## Financed through/by

– Ministry of Research, Innovation and Digitization institutional development project – projects to finance excellence in RDI

## Research Team

### Project leader:

- Assoc. Prof. Dr. Eng. Liviu-Ioan CĂDARIU-BRĂILOIU
- Assoc. Prof. Dr. Eng. Florin DRAGAN,
- Prof. Dr. Eng. Viorel UNGUREANU,
- Prof. Dr. Eng. Nicolae MUNTEAN,
- Prof. Dr. Eng. Liviu MARSAVINA,
- Prof. Dr. Eng. Petru NEGREA,
- Assoc. Prof. Dr. Eng. Bogdan RADU,
- Prof. Dr. Eng. Florica MANEA,
- Assoc. Prof. Dr. Eng. Octavian CORNEA,
- Lecturer Dr. Eng. Ioan BOTH

## Contact information

Assoc. Prof. Dr. Eng. Liviu-Ioan CĂDARIU-BRĂILOIU  
Department of Mathematics  
Adress: Victoria Square, no.2, 300006, Timisoara  
Phone: (+40) 0256403002  
Mobile: (+40) 725890983  
E-mail: liviu.cadariu-brailoiu@upt.ro  
Project Website: <https://perform-cdi100.upt.ro/>

## DEVELOPMENT OF ACTIVE METASURFACES WITH APPLICATIONS IN THE FIELD OF FREQUENCY SELECTIVE SURFACES

### Goal of the project

This interdisciplinary project aims at conception of novel electronically controlled metasurfaces, with targeted applications to frequency selective surfaces. The main objective of this modern research topic is to control at will the electromagnetic wave parameters such as intensity, phase, wavefront, beam direction and polarization by interaction with active metasurfaces. Significant advance is expected from this project in understanding and controlling the dynamic response of the metasurface to stimuli from a properly excited control network; both externally set and measured inputs are considered. Cost-effective systems like spatial filters, polarization converters and absorbers, with applications to screening, shielding and cryptic communication systems are expected to be conceived and prototyped. Outcomes involve publications in high-rank journals, important conferences and research reports.

### Short description of the project

- The main objective of the project is the development of innovative metasurfaces with applications in the field of frequency selective surfaces.

### Project implemented by

#### Coordinator:

Politehnica University Timisoara  
Faculty of Electronics, Telecommunications and Information Technologies,  
Department of Measurements and Optical Electronics

### Implementation period

01.04.2022 - 31.03.2024

### Main activities

- Theoretical study of passive structures and control networks. Numerical analysis and optimization of passive structures such as surfaces with ultra-wide band filtering, absorbers.
- Numerical design and development of innovative configurations such as: structures made only of dielectric material, structures with flexible substrate and active surfaces with controllable geometry. Numerical optimization by standard techniques of the excitation configuration, for a wide band answer for all the analyzed FSS structures.
- Prototyping, testing and validation of some of the proposed configurations (for example: absorbers, small active FSSs or all dielectric ones); Numerical optimization for a wide band response for the analyzed active FSS structures.

### Results

[I] A. De Sabata, L. Matekovits, A. Buta, G. Dassano, **A. Silaghi**, „Frequency Selective Surfaces for UWB Filtering and Shielding”, MDPI Sensors, 22(5), 1896, February 2022

(WOS:000773637200001, IF=3.847, ISI Q2 indexed journal paper, DOI: <https://doi.org/10.3390/s22051896>).

[II] A. De Sabata, L. Matekovits, **A. Silaghi**, L. Kouvalhandi, “Absorber Based on a Frequency Selective Surface Built on FR4 Substrate”, 2022 IEEE International Symposium on Antennas and Propagation and USNC-URSI Radio Science Meeting (AP-S/URSI 2022), Denver, USA, 10 – 15 July 2022, pp. 1-4, 2022

(DOI: [10.1109/AP-S/USNC-URSI47032.2022.9886569](https://doi.org/10.1109/AP-S/USNC-URSI47032.2022.9886569)).

[III] **A. Silaghi**, A. De Sabata, L. Matekovits, A. Buta, “Ultra-Wide Band Frequency Selective Surface: design and experimental validation of performances for wide incident angle”, 2022 International Conference on Electromagnetics in Advanced Applications (ICEAA 2022), 5-9 September 2022, Cape Town, South Africa, pp. 1-4, 2022, (DOI: [10.1109/ICEAA49419.2022.9899941](https://doi.org/10.1109/ICEAA49419.2022.9899941))

[IV] **A. Silaghi**, A. De Sabata, L. Matekovits, “Design of All Dielectric Frequency Selective Surfaces”, 2022 International Symposium on Electronics and Telecommunications (ISETC 2022), 14-15 November 2022, Timișoara, Romania, pp. 1-4, 2022

(DOI: [10.1109/ISETC56213.2022.10010290](https://doi.org/10.1109/ISETC56213.2022.10010290))

[V] **A. Silaghi**, F. Mir, A. De Sabata, L. Matekovits, "Design and Experimental Validation of a Switchable Frequency Selective Surface with Incorporated Control Network", *MDPI Sensors*, 23(9), 4561, May 2023 (WOS: 000988076200001, impact factor 3.847, ISI Q2 indexed journal, <https://doi.org/10.3390/s23094561>).

[VI] **A. Silaghi**, C. Pescari, A. De Sabata, L. Matekovits, "Design of Locally Deformed Flexible Frequency Selective Surfaces", 2023 International Symposium on Signals, Circuits and Systems (ISSCS), 13-14 July 2023, Iasi, Romania, pp.1-4, 2023 (DOI: [10.1109/ISSCS58449.2023.10190917](https://doi.org/10.1109/ISSCS58449.2023.10190917)).

[VII] A. De Sabata, O. Zeno-Lipan, L. Matekovits, **A. Silaghi**, "Comparison between Frequency Selective Surface with Rectangular and Hexagonal Periodicity Operating as Absorbers", 2023 International Conference on Electromagnetics in Advanced Applications (ICEAA), 9-13 October 2023, Venice, Italy, pp. 1-4, 2023 (DOI: [10.1109/ICEAA57318.2023.10297723](https://doi.org/10.1109/ICEAA57318.2023.10297723)).

[VIII] ] **A. Silaghi**, F. Mir, A. De Sabata, L. Matekovits, "Study Regarding the Influence of the Biasing Network in Designing a Switchable Frequency Selective Surface", 2023 International Conference on Electromagnetics in Advanced Applications (ICEAA), 9-13 October 2023, Venice, Italy, pp. 1-4, 2023 (DOI: [10.1109/ICEAA57318.2023.10297778](https://doi.org/10.1109/ICEAA57318.2023.10297778)).

## Applicability and transferability of the results

Results obtained in this research might be useful to:

- EMC Laboratories
- Antenna engineering
- Professionals working in Automotive design
- Legal authorities that regulate spectrum occupancy

## Financed through/by

UEFISCDI, project number PN-III-P1-1.1-PD-2021-0010

## Research Center

Research Center for Intelligent Electronic Systems

## Research Team

### Project leader:

- Assoc. Prof. Dr. Eng. Andrei-Marius SILAGHI

### Mentor:

- Assoc. Prof. Dr. Eng. Ladislau MATEKOVITS

## Contact information

Assoc. Prof. Dr. Eng. Andrei-Marius SILAGHI  
Faculty of Electronics, Telecommunications and Information Technologies,  
Department of Measurements and Optical Electronics  
Address: 2, Vasile Pärvan Blvd., 300223, Timisoara  
Mobile: (+40) 723 625 617  
E-mail: [andrei.silaghi@upt.ro](mailto:andrei.silaghi@upt.ro)  
Project Website: [www.metasuprafete.ro](http://www.metasuprafete.ro)

## A NEW TYPE OF VALVE TO CONTROL AND MITIGATE THE SWIRLING FLOW INSTABILITIES FROM THE CONICAL DIFFUSER OF HYDRAULIC TURBINES – HYDROVALVE

### Goal of the project

- The aim of the project is to demonstrate and validate on an experimental test rig the operation of a new type of valve which generates a pulsating water jet in order to eliminate/mitigate, the instabilities associated to the swirling flow from the conical diffuser of hydraulic turbines that operate far from their optimum efficiency point (at partial load). The introduction of the new type of valve is done by bypassing the main hydraulic circuit of the turbine (Fig. 1).

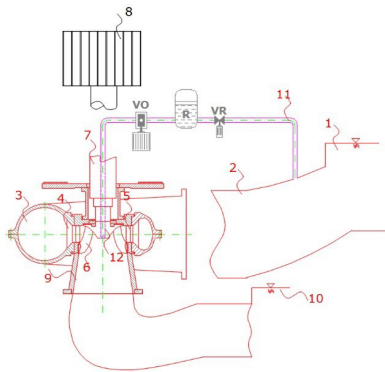

### Short description of the project

- Hydraulic turbomachines can experience severe pressure fluctuations when operated below their design conditions. Hydrodynamic instabilities generate severe pressure fluctuations in the conical diffuser. These pressure oscillations vary in amplitude and frequency depending on the operating point. The causes of these fluctuation changes are e.g. at part load in the 60% flow range, pressure pulsations induced by the helical vortex (or vortex rope). These phenomena have been known for a long time, but their effects are felt more acutely today. The entire academic community and design engineers recognize that the problem of far-from-optimal regimes is still open and await effective technical solutions that can be implemented in hydropower plants to substantially improve flexibility in hydropower exploitation. The rope vortex phenomenon is associated with severe vibrations and pressure pulsations. It can excite all parts of the hydraulic and structural system, leading to serious problems such as: pressure fluctuations, fatigue effects, vibrations, power oscillations, noise. To summarize the above, the aim of the project is to demonstrate and validate on a test rig the operation of a new type of valve that generates a pulsating water jet to eliminate / mitigate the instabilities associated with the swirling flow in the conical diffuser of hydraulic turbines operating at part load.

The introduction of the new type of valve is done by bypassing the main hydraulic circuit of the turbine.

### Project implemented by

Coordinator: Politehnica University Timisoara

### Implementation period

07.2022 - 07.2024

### Main activities

1. Manufacturing the new VO.
2. Implementing the new VO on the circuit of the test rig.
3. Testing the new VO on the test rig.
4. Experimental measurements and validation.

### Results

- **Objective 2 and 3** with the planned activities, related to the stage of 2023, were fulfilled, by implementing and testing the new device (Fig. 2). The degree of achievement of the deliverables in this stage was 100% (patent application).

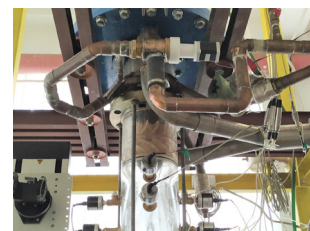

## Applicability and transferability of the results

- Next step is to test the new device to proff the concept by experimental measurements of unsteady pressure field.

## Financed through/by

UEFISCDI

## Research Center

Research Institute for Renewable Energies

## Research Team

### Project leader:

- Dr. Eng. Constantin TĂNASĂ

### Researchers:

- Prof. Dr. Eng. Romeo SUSAN-RESIGA

- Assoc. Prof. Dr. Eng. George BELGIU

- Assoc. Prof. Dr. Eng. Adrian STUPARU

- Assist. Prof. Dr. Eng. Tiberiu CIOCAN

- Lecturer Dr. Eng. Alin BOSIIOC

## Contact information

Dr. Eng. Constantin TĂNASĂ

Research Institute for Renewable Energies - UPT

Address: 138 Gavril Musicescu street, 300501, Timișoara

Mobile: (+40) 720741338

E-mail: constantin.tanasa@upt.ro

Project Website:

<http://hydrovalve.upt.ro>



## MEDIATIZATION AND CULTURE OF DIGITALIZATION: IMPACT IN THE FIELD OF TRANSLATION STUDIES

### Goal of the project

- This project aimed at strengthening the cooperation between **Paul Valery University in Montpellier** and **Politehnica University Timisoara**.
- It consisted of a mobility internship at Politehnica University carried out by Professor Mihaela-Alexandra TUDOR BRATOSIN, a well-established scholar in the fields of **mediatization** and **new media technologies** and focused on an exchange of good research and pedagogical practices in the fields of **mediatization theories** and **translation studies**.



### Short description of the project

- Translation is a field directly affected by the growth of new information and communication technologies (ICT) and, more recently, artificial intelligence (AI).
- The complex environment created by emerging media resulting from ICT calls into question many aspects of traditional theories in the field and lays the foundations for epistemological questions that would find answers in emerging research in communication sciences related to theories of mediatization.
- The interdisciplinary dialogue developed within the boundaries of this project focused on identifying new research opportunities connected to relevant international research in the fields of translation and media studies.

### Project implemented by

- Prof. Dr. Habil. Daniel Dejica-Cartis, project coordinator,  
Director of Politehnica Center for Advanced Translation Studies  
Coordinator: Politehnica University Timisoara

### Implementation period

21-27 November 2023

### Main activities

- The main activities consisted of a series of meetings and talks, including a workshop within the Days of the Faculty of Communication Sciences (<https://sc.upt.ro/ro/noutati/775-serie-de-evenimente-policat>), a round table with the faculty members ([https://www.sc.upt.ro/images/6\\_research-based.jpeg](https://www.sc.upt.ro/images/6_research-based.jpeg)) and a meeting with doctoral students ([https://www.sc.upt.ro/images/5\\_doing\\_research.jpeg](https://www.sc.upt.ro/images/5_doing_research.jpeg)).

### Results

- The expected results include, but are not limited to:
  - (1) the publication of articles in mainstream journals,
  - (2) the development of a common course based on research related to translation studies and mediatization theories,
  - (3) the creation of an interdisciplinary academic research network under the tutelage of the two institutions involved in the visit (CORHIS-UPVM3 and PoliCAT UPT),
  - (4) coordination of a thematic journal file (Essachess) on these topics.



## Applicability and transferability of the results

- The expected results will open the way to new cooperation opportunities, including the organization of international co-supervision PhDs.

## Financed through/by

UEFISCDI - PN-IV-P2-2.2-MCD-2023-0042

## Research Center

PoliCAT - Politehnica Center for Advanced Translation Studies

## Research Team

- Prof. Dr. Daniel Dejica-Cartis, **project coordinator**, Politehnica Center for Advanced Translation Studies, Politehnica University Timisoara, Romania
- Prof. Dr. Mihaela-Alexandra TUDOR BRATOSIN, CORHIS, Paul Valery University Montpellier 3, France

## Contact information

Prof. Dr. Daniel DEJICA-CARȚIȘ  
Faculty of Communication Sciences  
Department of Communication and Foreign Languages  
2, Petre Râmneanțu street,  
300596 - Timișoara, Timiș, România  
Phone: (+40) 256 404014  
E-mail: daniel.dejica@upt.ro

# INTERNATIONAL RESEARCH PROJECTS



## EASTERN EUROPEAN TWINNING ON STRUCTURAL INTEGRITY AND RELIABILITY OF ADVANCED MATERIALS OBTAINED THROUGH ADDITIVE MANUFACTURING (SIRAMM)

### Goal of the project

The overall objective of the SIRAMM project is to significantly strengthen research in the **Additive Manufacturing (AM) field** at the Politehnica University Timișoara. To achieve this aim, SIRAMM will build upon the existing science and innovation base of UPT, creating a network with two internationally-leading counterparts at EU level: Norwegian University of Science and Technology (Norway) and the University of Parma (Italy).

In the long term, the project aims at laying the foundations for creating a pole of excellence on AM in Eastern Europe. For this reason, other two partners from low R&I performing countries, the University of Belgrade (Serbia) and the Institute of Physics of Materials, Academy of Sciences (Czech Republic) also take part in this Twinning project.

### Short description of the project

The project is focused on the implementation of knowledge transfer activities such as workshops and staff exchange, training events (i.e. summer schools, seminars) for early stage researchers, dissemination and communication actions (i.e. web site, videos, open access publications, public engagement activities) for different audiences. To keep maintaining the knowledge transfer well beyond the duration of this project, a regular master course on AM technology was implemented in the coordinating institution.

### Project implemented by

1. **Coordinator: Politehnica University Timișoara (UPT), Romania**
2. Faculty of Mechanical Engineering, University of Belgrade (UBG), Serbia
3. Institute of Physics of Materials, Academy of Sciences of the Czech Republic (IPM), Czech Republic
4. University of Parma (UniPR), Italy
5. Norwegian University of Science and Technology (NTNU), Norway

### Implementation period

01.10.2019 – 31.03.2023

### Main activities

- Organization of the 2<sup>nd</sup> **Workshop on Structural Integrity of Additively Manufactured Materials**, Brno (Czech Republic), 4-5 February 2022 and 2<sup>nd</sup> **Winter School Trends on Additive Manufacturing for Engineering Applications**, Brno (Czech Republic), 6 – 10 February 2021;
- Organization of the 3<sup>rd</sup> **Workshop on Reliability and Design of Additive Manufactured Materials**, Belgrade (Serbia), 4 - 6 October 2022;

- Study of the influence of manufacturing parameters on the mechanical properties and fracture toughness of 3D printed specimens.
- Continuation of the staff and PhD exchange between partners.



### Results

In 2022 the consortium published the following journal papers:

- AILINEI, I. I., GALATANU, S. V., & MARSAVINA, L. (2022). INFLUENCE OF ANISOTROPY ON THE COLD BENDING OF S600MC SHEET METAL. ENGINEERING FAILURE ANALYSIS, 137, 106206, DOI: 10.1016/J.ENGFAILANAL.2022.106206
- BRIGHENTI R., MARSAVINA L., MARGHITAS M.P., COSMA M.P., MONTANARI M. (2022) MECHANICAL CHARACTERIZATION OF ADDITIVELY MANUFACTURED PHOTOPOLYMERIZED POLYMERS. MECH. OF ADVANCED MATERIALS & STRUCTURES, DOI:10.1080/15376494.2022.2045655
- L. MARŞAVINA, C. VĂLEAN, M. MĂRGHIŢAŞ, E. LINUL, S. M. J. RAZAVI, F. BERTO, R. BRIGHENTI (2022) EFFECT OF THE MANUFACTURING PARAMETERS ON THE TENSILE AND FRACTURE PROPERTIES OF FDM 3D-PRINTED PLA SPECIMENS. ENG. FRACTURE MECHANICS, 274, 108766, 2022, DOI: 10.1016/J.ENGFRACMECH.2022.108766

- ŞERBAN, D. A., COŞA, A. V., BELGIU, G., & NEGRU, R. (2022). FAILURE LOCUS OF AN ABS-BASED COMPOUND MANUFACTURED THROUGH PHOTOPOLYMERIZATION. POLYMERS, 14(18), 3822., DOI:10.3390/POLYM14183822

- IMANI, D. M., ALIHA, M. R. M., LINUL, E., & MARSAVINA, L. (2022). A SUITABLE MIXED MODE I/II TEST SPECIMEN FOR FRACTURE TOUGHNESS STUDY OF POLYURETHANE FOAM WITH DIFFERENT CELL DENSITIES. THEORETICAL AND APPLIED FRACTURE MECHANICS, 117, 103171, DOI: 10.1016/J.TAFMEC.2021.103171

- STOIA, D. I., LINUL, E., & MARSAVINA, L. (2022). MIXED-MODE I/II FRACTURE PROPERTIES OF SELECTIVELY LASER SINTERED POLYAMIDE. THEORETICAL AND APPLIED FRACTURE MECHANICS, 121, 103527, DOI: 10.1016/J.TAFMEC.2022.103527

- STOIA, D. I., GALATANU, S. V., & MARSAVINA, L. (2022). IMPACT PROPERTIES OF LASER SINTERED POLYAMIDE, ACCORDING TO BUILDING ORIENTATION. JOURNAL OF MECHANICAL SCIENCE AND TECHNOLOGY, 36, 1-5, DOI: 10.1007/S12206-022-2108-0.



2<sup>nd</sup> Workshop on Structural Integrity of Additively Manufactured Materials, Brno (Czech Republic), 4-5 February 2022



3<sup>rd</sup> Workshop on Reliability and Design of Additive Manufactured Materials, Belgrade (Serbia), 4 - 6 October 2022

## Financed through/by

European Commission, H2020-WIDESPREAD-2018-03 (action: CSA) under the grant agreement No. 857124



## Research Team

- Politehnica University Timisoara (UPT), Romania:

**Project coordinator: Prof. Dr. Eng. Liviu Marsavina;**

- University of Belgrade (UBG), Faculty of Mechanical Engineering, Serbia:

**UBG's project coordinator:** Prof. Dr. Eng. Aleksandar Sedmak;

- Institute of Physics of Materials, Czech Academy of Sciences, (IPM):  
IPM's project coordinator: Dr. Lubos Nahlik,

- University of Parma, Dept. of Engineering & Architecture (UNIPR):

**UNIPR's project coordinator:** Prof. Dr. Eng. Roberto Brighenti;

- Norwegian University of Science and Technology (NTNU) Trondheim, Norway:

NTNU's project coordinator: Prof. Dr. Eng. Filippo Berto

## Research Center

"St. Nadasan" Research Laboratory for Strength, Integrity and Durability of materials, structures and conductors

## Contact information

Prof. Dr. Eng. Liviu MARSAVINA

Faculty of Mechanical Engineering

Department of Mechanics and Strength of Materials

Address: 1 Mihai Viteazu Blvd., 300222, Timisoara

Phone: (+40) 256 403577

Mobile: (+40) 726 397635

E-mail: liviu.marsavina@upt.ro

Project Website: <http://www.siramm.unipr.it/>

## LIVED-IN HERITAGE: PERSPECTIVES ON EUROPEAN CULTURAL LANDSCAPES FROM ARCHITECTURE SCHOOLS

### Goal of the project

- The impact of the proposed project is to promote cooperation between academia and practice in the field of cultural heritage at European level, with a specific focus on the notion of cultural landscape in historic urban context through the paradigm of living heritage: engaging people in heritage decision-making and ensuring heritage serves their wellbeing.
- Building on the experience of European exchanges within the Network of Schools of Architecture connected with European Heritage Cities - SAWHC, we propose a collaboration of three universities and their proximal World Heritage Sites: Politehnica University Timisoara has near the Monumental Ensemble of Târgu Jiu enlisted on World Heritage Tentative List, The University of Edinburgh and the Old and New Towns of Edinburgh listed od World Heritage Sites no. 728, in 1995 Yuriy Fedkovych Chernivtsi National University and the Residence of Bukovinian and Dalmatian Metropolitans listed od World Heritage Sites no.1330 in 2011.

### Short description of the project

- The project involved academics and postgraduate students from the three universities and colleagues from the wider network of Schools of Architecture connected with European Heritage Cities for a series of two online 1-day meetings and one 4-day on-site workshop in Târgu Jiu.
  - The choice of sites was meant to pre-empt the impact of potential Covid travel restrictions on the project, meaning the universities will still have access to their respective sites.
- Likewise, the joint on-site workshop in Târgu Jiu will be planned with alternative, on-line collaborative means in place in case of Covid restrictions.
- The final, corollary meeting in September 2022 was dedicated to developing together ideas and methodologies for understanding the cultural landscape dimension of heritage and its role for the wellbeing of communities.
  - This was meant to feature online public events in the form of case-studies/guided tours of the three sites for European Heritage Days in 2022.

### Project implemented by

**Coordinator:** Politehnica University Timisoara

### Partners:

- The University of Edinburgh
- Scottish Centre for Conservation Studies
- Yuriy Fedkovych Chernivtsi National University, Ukraine



Council of Europe



Romanian Ministry of Culture  
Ukrainian Ministry of Culture



European Heritage Days



## Implementation period

8.03.2022 – 28.02.2023

## Main activities

- The first, exchange meeting in March 2022 provided a fertile medium for cross-border cooperation sharing experiences from different European perspectives on the cultural landscape dimensions of their respective European Heritage.
- The on-site workshop in July 2022 aimed to connect with the local community and co-operate with heritage institutions managing the site in investigating the cultural landscape dimension of the Monumental Ensemble of Țârgu Jiu.
- The final, meeting in September 2022 was dedicated to developing together ideas and methodologies for understanding the cultural landscape dimension of heritage and its role for the wellbeing of communities. The proceedings of the meetings and the findings of the workshop will be written up by February 2023 for a multi-lingual online publication in open access format, hosted by the University of Edinburgh.

## Results

- Due to the fact that all 3 sites chosen for the workshops contain high values, from historical events, landscape, fine arts, personalities, represents a good opportunity to maintain awake the public interest in each local community. The gain of these experiences will be the fresh view, within the students eyes, filtrated by personal experience. The published results will enter in public domain, with the possibility to access by EHDs followers from any country. The programme proposed for EHD 2021-2020 CROSS-FRONTIER CO-OPERATION PROJECTS is direct connected to the next two years of EHD themes voted, in Romania, as title and content – 2022 – **Sustainable heritage and 2023 – Living heritage**. This would fit well with the Doors Open Day programme, with scheduling of events and activities that could fit with the regional programme for Edinburgh, as well as offering a national output through the **Doors Open Days website**.

## Applicability and transferability of the results

Workshop tasks established were: familiarisation with the site and its contexts (visits and discussions); investigation of lived-in heritage in mixed groups from the three universities (historic data, surveys/interviews, photography, video); presentation of preliminary findings.

## Financed through/by

Council of Europe

“European Cross-Frontier Cooperation Projects” within the framework of the European Heritage Days joint action of the Council of Europe and the European Union EAC/A05/2021 – BH4788 PMM 2847

## Research Center

Research Center in Urban Planning and Architecture, Faculty of Architecture

## Research Team

### Project leader:

– Assoc. Prof. Dr. Arch. Ileana KISILEWICZ

### Partners:

– Assoc. Prof. Dr. Arch. Ruxandra STOICA

– Prof. Dr. Arch. Juliana BALANIUK

– Assoc. Prof. Dr. Arch. Audrey DAKIN

– Dr. Arch. Victor Dan KISILEWICZ

### Researchers:

– Ph. D. Student Arch. Inna OSTROVSCA

– Ph. D. Student Eng. Simona Daciana DANI

– M. Sc. Student Arch. Alice Megan SMITH

– M. Sc. Student Arch. Evelyn M.V. SMITH

– M. Sc. Student Arch. Erin CHECKOSKY

– M. Sc. Student Arch. Molly DONAHUE

## Contact information

Assoc. Prof. Dr. Arch. Ileana KISILEWICZ

Faculty of Architecture

Address: 2, Traian Lalescu Street, 300223, Timisoara, Timis county

E-mail: ileana.kisilewicz@upt.ro

Project Website: [https://blogs.ed.ac.uk/lived-in\\_heritage/](https://blogs.ed.ac.uk/lived-in_heritage/)



## DESIGN AND DEVELOPMENT OF AN ENERGY EFFICIENCY MANAGEMENT AND CONTROL SYSTEM WITH COST-EFFECTIVE SOLUTIONS FOR RESIDENTIAL AND EDUCATIONAL BUILDINGS – DOITSMARTER



### Goal of the project

DOITSMARTER will provide an end-to-end solution for customers' energy management needs, based on demand side management for energy & cost savings. The proposed Energy Management and Control System will elaborate control decisions from cost perspective among other factors.

The main objectives of the project are:

- To design, develop and test Energy Management and Control algorithms and tools for the optimization of a Smart Building, with residential homes and apartments reducing the energy consumption of the house and the costs with up to 20%;
- To develop, test and demonstrate cost-effective power-to-heat solutions using heat pumps and heat boosters with relay plug-in communication modules for district heating and cooling systems;
- To install and demonstrate cost-effective and user-friendly solutions in three Demo pilots with Residential Houses and public buildings in Romania and Norway.

### Short description of the project

The project focuses on the integration and coordination aspects of an enhanced set of technologies and tools applied to demonstrate how to improve efficient and secure exploitation smart buildings under increasing share of renewables.

- Development and testing different Smart Buildings Pilot Concepts in Norway and Romania;
- Dissemination, exploitation and communication.

### Project implemented by

- Technical University of Cluj-Napoca
- Oestfold University College
- NxTech AS
- Politehnica University Timisoara
- Center for the Study of Democracy
- Alba Iulia City Hall

### Implementation period

May 2022 - December 2023

### Results

- The project will focus on developing practical solutions for an Energy Management and Control System demonstrated in 3 pilot sites for building environment, that integrate and combine different energy technologies – RES with Battery Storage technologies, HVAC system control, lighting, heating and cooling, Demand Response (DR) – into an innovative Building Energy Management System, to ensure an efficient and optimized energy management and the coverage of the highest possible share of RES, both at the single building level and at a community of building level.

### Main activities

- Specification analysis/Requirements, Standardization activities, Reference cases & Business models;
- Development of innovative algorithms & tools for an Energy Management and Control System;
- Design and development of an IoT communication platform-based hierarchy building energy management system for different setups in existing buildings;

## Applicability and transferability of the results

The practical solutions proposed for the Energy Management and Control System developed in this project can be further adapted to be used in other similar scenarios.

## Financed through/by

Innovation Norway

## Research Center

Research Center for Automatic Systems Engineering

## Research Team

- Assoc. Prof. Dr. Eng. Cristian VASAR
- Assist. Prof. Dr. Eng. Dorin BORDEASU
- Assoc. Prof. Dr. Eng. Iosif SZEIDERT
- Prof. Dr. Eng. Ioan FILIP

## Contact information

Assoc. Prof. Dr. Eng. Cristian VASAR  
Faculty of Automation and Computing  
Department of Automation and Applied Informatics  
2, Vasile Parvan Blvd., 300223  
Timisoara  
Phone: (+40) 256 403 237  
E-mail: cristian.vasar@upt.ro  
Project Website: <https://entrec.utcluj.ro/doitsmarter/>

## COMBINATORIAL DESIGN OF NOVEL BIPOLAR PLATE COATINGS FOR PROTON EXCHANGE MEMBRANE ELECTROLYZERS (CODE-PEM)

### Goal of the project



The CoDe-PEM project aims to contribute towards the development of affordable PEM electrolysis systems with the development of lower cost coating materials for bipolar plates and sinters. In order to lower the costs, a reduction in use of expensive materials and the introduction of new low(er) cost materials are key elements. In addition, new materials should allow for fast and low-cost manufacturing processes, such as stamping of BPP flow structures.

### Short description of the project

In order to achieve its goals, the CoDe-PEM Project will:

- Accelerate innovation research of novel coating compositions by the use of combinatorial exploration.
- Improve efficiency and reduce time of testing and characterization of BPPs by the use of advanced electrolyser test cell
- Identify factors affecting the durability of BPP materials based on in situ experiments and post mortem failure analysis.
- Raise public awareness concerning the importance and advantages of using hydrogen based clean energy and the potential for growth in a healthy and sustainable economy.

### Project implemented by

Politehnica University Timisoara, Romania  
SINTEF Industry, Norway

### Implementation period

2019–2023

### Main activities

- Coating development via combinatorial exploration
- Ex-situ characterization of coatings and coated substrates
- Bipolar plates design, testing and evaluation
- Dissemination and public awareness activities

### Results



Fig. 1. System for deposition of compositional spread libraries installed in Politehnica University Timisoara

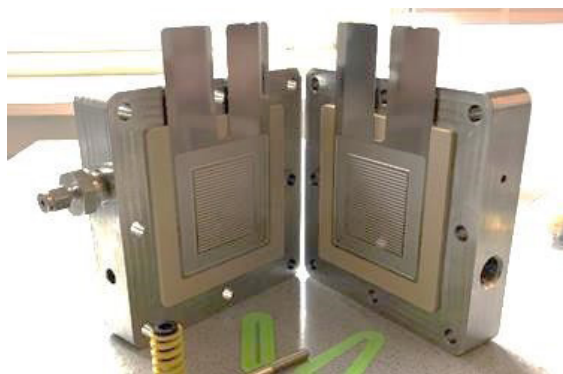

Fig. 2. Test cell developed in SINTEF

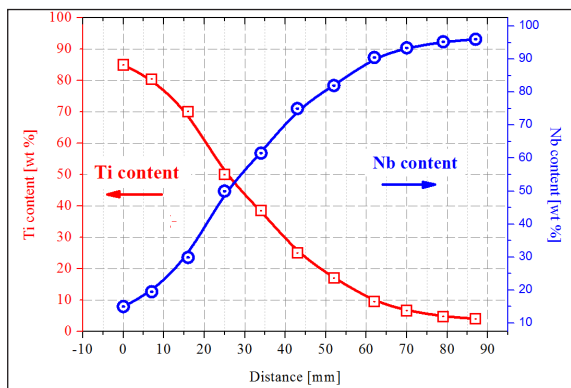

Fig. 3. Compositional map of a binary library manufactured in Politehnica University Timisoara



Fig. 4. Partner's meeting in SINTEF

## Applicability and transferability of the results

The technical solutions developed in the project have the potential to reduce the costs for hydrogen generated via proton exchange membrane electrolysis.

## Financed through/by

**Iceland  
Liechtenstein  
Norway grants**

**uefiscdi**  
Executive Agency for Higher  
Education, Research, Development  
and Innovation Funding

**EEA Grants 2014-2021**  
Administered by UEFISCDI

More information about EEA Grants can be found here:  
[www.eegrants.org/](http://www.eegrants.org/) and [www.eegrants.ro](http://www.eegrants.ro)

## Research Center

### Politehnica University Timisoara:

- Combinatorial exploration group
- Fuel cell group

### SINTEF Industry:

- New energy solutions group
- Corrosion and tribology group

## Research Team

### Politehnica University Timisoara:

- Prof. Dr. Eng. Corneliu M. CRACIUNESCU
- Prof. Dr. Eng. Nicolae VASZILCSIN
- Prof. Dr. Eng. Ion MITELEA
- Assoc. Prof. Dr. Eng. Aurel ERCUTA
- Assoc. Prof. Dr. Eng. Andrea KELLENBERGER
- Lecturer Dr. Eng. Mircea DAN
- Ph.D. Student Eng. Delia DUCA
- Ph.D. Student Eng. Mihaela LABOSEL
- Ph.D. Student Eng. Vlad BOLOCAN
- Ph.D. Student Eng. Andrei NOVAC

### SINTEF Industry:

- Dr. Anders ØDEGÅRD
- Dr. Sigrid LÆDRE
- Dr. Alejandro OYARCE
- Eng. Ole E. KONGSTEIN
- Eng. Ann-Karin KVERNBRÅTEN

## Contact information

Prof. Dr. Eng. Habil. Corneliu CRACIUNESCU  
Faculty of Mechanical Engineering  
Department of Materials and Manufacturing Engineering  
Address: 1 Mihai Viteazu Blvd., 300222, Timisoara  
Phone: (+40) 256 403 655  
E-mail: [corneliu.craciunescu@upt.ro](mailto:corneliu.craciunescu@upt.ro)  
Project Website: <https://www.sintef.no/projectweb/codepem//>

## ENGAGED AND ENTREPRENEURIAL EUROPEAN UNIVERSITY AS DRIVER FOR EUROPEAN SMART AND SUSTAINABLE REGIONS (E<sup>3</sup>UDRES<sup>2</sup>)

### Goal of the project

E<sup>3</sup>UDRES<sup>2</sup> is a **European Universities Alliance** – a network of higher education institutions located in Europe, that have decided to closely work together and collaborate in the field of research, teaching, innovation and much more. The project is focusing on:

- Co-Innovate Smart and Sustainable European Regions
- Co-Ideate a Future University for future-skilled learners
- Co-Create a European Multi-University Campus

E<sup>3</sup>UDRES<sup>2</sup> co-creates outstanding ideas and concepts for future universities for future-skilled learners, integrates challenge-based education, mission-oriented research, human-centered innovation as well as open and engaged knowledge exchange as interrelated core areas and establishes an exemplary multi-university campus across Europe.

### Short description of the project

The project is one of the 41 consortiums selected for funding as part of the European Commission Initiative towards creating a number of European Universities.

### Project implemented by:

**Coordinator:** St. Pölten University of Applied Sciences, Austria

### Partners:

- Politehnica University Timisoara, Romania
- Polytechnic Institute of Setúbal, Portugal
- Hungarian University of Agriculture and Life Sciences, Hungary
- UC Leuven-Limburg University of Applied Sciences, Belgium
- Vidzeme University of Applied Sciences, Latvia
- Saxion University of Applied Sciences, Netherlands
- Fulda University of Applied Sciences, Germany
- Jyväskylä University of Applied Sciences, Finland

### Implementation period

01.11.2020 – 30.09.2023

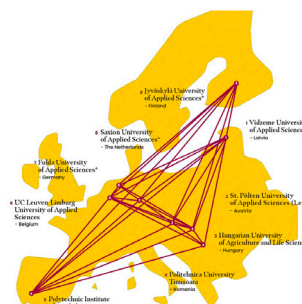

Map EUDRES



EUDRES St. Pölten



EUDRES Timisoara

### Main activities

E<sup>3</sup>UDRES<sup>2</sup> is looking for new and innovative educational formats:

- **EUDRES Hackathons** are short, challenge-based events where teams of students, university staff and citizens try to come up with an innovative solution to their challenge
- **EUDRES Bootcamps** are involving student teams to get together to work on regional challenges for one week, always being closely linked to the needs of the region and local challenge owners.

- **EUDRES I Living Labs** are making international student teams collaborate to work on challenges over the course of several weeks, having the time to tackle challenges with in-depth solutions (in total, 273 ILL were organized in intensive, classical or blended formats) The researchers collaborating in **EUDRES** are organized in three research networks – Circular Economy, Wellbeing & Active Ageing and Human Contribution to Artificial Intelligence. They are responsible for writing proposals, carrying out Citizen Science projects as well as hosting annual **Research Living Labs**.

## Results

The EUDRES alliance officially established and adopted its Vision & Mission document. This vision is put into practice through key deliverables:

- A model for the governance of a progressive European University.
- A common educational model for students by offering open educational resources, shared modules and joint degrees with mobility opportunities.
- Offer of I-Living Labs, I-research networks and I-cubator programmes for future universities and smart sustainable regions. The I stands for inspiring, innovative, international, interdisciplinary, inter-sectoral, inclusive and intense.
- Co-creation activities that promote open and engaged knowledge exchange that contribute and interact with regional communities, and are acknowledged as good practice on a European level.
- EUDRES 2030 Blueprint (Vision for the University of the Future)

The final E<sup>3</sup>UDRES<sup>2</sup> meeting took place in St. Pölten University of Applied Sciences, Austria on 18–20 September 2023. The E<sup>3</sup>UDRES<sup>2</sup> Forum: Connecting European Universities & Regions has been organized on that occasion, with a participation of about 150 experts from all countries involved in the project – leaders and coordinators of E<sup>3</sup>UDRES<sup>2</sup>, academic and non-academic staff, student representatives, members of the Advisory Board, representatives of the E<sup>3</sup>UDRES<sup>2</sup> associate partners from Ukraine and Western Balkans, associate partners from regional authorities, members of the European Commission and national authorities, representatives of other similar alliances.

## Applicability and transferability of the results

E<sup>3</sup>UDRES<sup>2</sup> promotes the development of small and medium-sized cities and their rural environments into smart and sustainable regions and shapes a prosperous future with the best possible quality of life for a self-determined people in a progressive European society. The project aims to develop further co-operation applications under Horizon Europe, Erasmus+ KA2, Marie Curie doctoral consortiums and other international funded calls.

## Financed through/by

European Commission, EPP-EUR-UNIV-2020

## Research Team

### Project director:

- Assoc. Prof. Dr. Eng. Florin DRĂGAN

### Project coordinator:

- Prof. Dr. Eng. Radu VASIU

### Researchers:

- Prof. Dr. Eng. Liviu MARȘAVINA
- Assoc. Prof. Dr. Mat. Liviu CĂDARIU-BRĂILOIU
- Prof. Dr. Eng. Daniel DAN
- Assoc. Prof. Dr. Eng. Diana ANDONE
- Lecturer Dr. Eng. Vlad MIHĂESCU
- Lecturer Dr. Eng. Valentin NIȚĂ
- Assoc. Prof. Dr. Eng. Silviu VERT
- Lect. Dr. Eng. Andrei TERNAUCIUC
- Assoc. Prof. Dr. Ec. Lavinia MIHALI
- Prof. Dr. Eng. Viorel UNGUREANU
- Assoc. Prof. Dr. Eng. Alexandru IOVANOVICI
- Assoc. Prof. Dr. Eng. Razvan BOGDAN
- Assoc. Prof. Dr. Eng. Attila SIMO
- Assoc. Prof. Dr. Eng. Valentin CIUPE
- Assoc. Prof. Dr. Eng. Mihaela - Codruța ANCUȚI
- Assoc. Prof. Dr. Arh. Cristina POVIAN
- Assist. Prof. Dr. Eng. Cristian ȚECU
- Assoc. Prof. Dr. Eng. Cristian MOLDOVAN
- Assist. Prof. Dr. Eng. Nataliia RUDENKO
- Prof. Dr. Eng. Sorin HERBAN
- Assoc. Prof. Dr. Eng. Sergiu GĂLĂȚANU
- Assoc. Prof. Dr. Eng. Mihaela CRIȘAN-VIDA
- Assoc. Prof. Dr. Eng. Alin TOTOREAN
- Prof. Dr. Eng. Calin Adrian POPA
- Prof. Dr. Eng. Cosmin CERNĂZANU-GLĂVAN
- Prof. Dr. Ec. Claudiu ALBULESCU
- Assoc. Prof. Dr. Eng. Claudia STOIAN
- Assist. Prof. Dr. Eng. Norbert GAL-NĂDĂȘAN
- Assist. Prof. Dr. Eng. Robert KRISTOF
- Assoc. Prof. Dr. Eng. Dan-Ioan STOIA
- Assoc. Prof. Dr. Eng. Andreea STOIA
- Assoc. Prof. Dr. Eng. Emanoil LINUL
- Assoc. Prof. Dr. Eng. Flaviu FRIGURA
- Prof. Dr. Eng. Alina DUMITREL
- Assoc. Prof. Dr. Eng. Adrian DOGARIU

## Contact information

Prof. Dr. Eng. Radu VASIU, Faculty of Electronics, Telecommunications and Information Technologies, Department of Communications  
Address: Victoriei Square, no.2, 300006, Timisoara  
Phone: (+40) 256 403 324  
Mobile: (+40) 722 516 555  
E-mail: radu.vasiu@upt.ro  
Project Website: <https://eudres.eu>

## ENGAGED AND ENTREPRENEURIAL EUROPEAN UNIVERSITY AS DRIVER FOR EUROPEAN SMART AND SUSTAINABLE REGIONS 2.0 - E<sup>3</sup>UDRES<sup>2</sup> 2.0

### Goal of the project

E<sup>3</sup>UDRES<sup>2</sup> 2.0 empowers the further development of E<sup>3</sup>UDRES<sup>2</sup>, the Engaged and Entrepreneurial European University as Driver for European Smart and Sustainable Regions, to reach a substantial leap in quality, performance, attractiveness and competitiveness of the European University alliance and its individual members. The E<sup>3</sup>UDRES<sup>2</sup> alliance started from scratch in October 2020 with initially six higher education institutions. The consortium of E<sup>3</sup>UDRES<sup>2</sup> 2.0 unites 10 higher education institutions as well as 36 associated partners. In addition, E<sup>3</sup>UDRES<sup>2</sup> 2.0 establishes enhanced partnerships with universities and their local communities from Western Balkans and the Ukraine.

E<sup>3</sup>UDRES<sup>2</sup> vision is to promote **Smart and Sustainable Regions (S<sup>2</sup>-Regions)** to shape a peaceful and prosperous European future for responsible citizens as a pioneering full-fledged Engaged and Entrepreneurial European University (E<sup>3</sup>-Universities).

E<sup>3</sup>UDRES<sup>2</sup> mission is to inspire open-minded people to co-create solutions for environmental, societal and economic challenges, support individual learners to unleash their talents and develop future-oriented skills, empower creative Ent-r-e-novators (entrepreneurs, researchers, educators and innovators) and act as an inclusive and engaged platform for collaborative innovation that strengthens a smart and sustainable society.

### Short description of the project

The project is one of the 41 consortiums selected for funding as part of the European Commission Initiative towards creating a number of European Universities, that have been approved to enter the second phase of implementation.

### Project implemented by:

**Coordinator:** St. Pölten University of Applied Sciences (STPUAS), Austria

### Partners:

- Politehnica University Timisoara (UPT), Romania
- Polytechnic Institute of Setúbal (IPS), Portugal
- Hungarian University of Agriculture and Life Sciences (MATE), Hungary
- University College Leuven, Belgium
- University College Limburg, Belgium
- Vidzeme University of Applied Sciences (ViA), Latvia
- Saxion University of Applied Sciences (Saxion), Netherlands
- Fulda University of Applied Sciences (HFD), Germany
- Jyväskylä University of Applied Sciences (JAMK), Finland

### Implementation period

01.10.2023 – 30.09.2027

### Main activities

E<sup>3</sup>UDRES<sup>2</sup> strives to enable Smart Learners to unfold talents, empowers ent-r-e-novators (entrepreneurs, researchers, educators, innovators) to accelerate future universities, serves as a platform for collaborative innovation to connect entrepreneurial minds, engages in regional communities to contribute to society and shifts to a fully-fledged European university to ensure excellent quality.

A major change against the first phase of the alliance is a clear sharing of leading and co-leading roles, to better make use of the existing high-level commitment in all institutions. The project planned to have one lead and two co-lead institutions for every WP:

- **WP 1** Project Management and Coordination: STPUAS (lead), HFD & ViA (co-leads)

E<sup>3</sup>UDRES<sup>2</sup>  
Engaged and Entrepreneurial European University as  
Driver for European Smart and Sustainable Regions



Map EUDRES

- **WP 2** Developing Talents: MATE (lead), Saxion & UPT (co-leads)
  - **WP 3** Smart Learners: UCLL (lead), JAMK & MATE (co-leads)
  - **WP 4** Research and Knowledge Serving Users: UPT (lead), HFD & IPS (co-leads)
  - **WP 5** Regional Innovation Hubs: Saxion (lead), STPUAS & UCLL (co-leads)
  - **WP 6** Future University: ViA (lead), HFD & STPUAS (co-leads)
  - **WP 7** Capacity Building: HFD (lead), Saxion & ViA (co-leads)
  - **WP 8** Quality and Evaluation: IPS (lead), JAMK & STPUAS (co-leads)
  - **WP 9** Digitalisation and Infrastructure: JAMK (lead), STPUAS & UPT (co-leads)
  - **WP 10** Impact and Dissemination: STPUAS (lead), IPS & UCLL (co-leads)
- E<sup>3</sup>UDRES<sup>2</sup> co-creates its **Multi-i-Campus** for flexible learning offering joint lectures, modules, internships, micro-credentials and (European) degrees, a talent funnel for smart learners, a joint support centre, joint doctoral programmes and research centres of excellence, an entrepreneurship and innovation network for S<sup>2</sup>-Regions, interconnected (pre-)incubators fostering startups entrepreneurial

# Research Report 2023

education, an ecosystem for regional partners and citizens, a proactively operating umbrella organisation as a legal entity and a future university model as an updated E<sup>3</sup>UDRES<sup>2</sup> strategy ensuring a fully-fledged European University sustainably implemented beyond 2030. In the first three years, E<sup>3</sup>UDRES<sup>2</sup> members pooled their expertise and resources into the three Research Networks for Circular Economy, Wellbeing and Active Ageing and Human Contribution to AI, whose thematic orientation shaped the activities for education and innovation, too. With regard to the specific challenges, opportunities and smart specialisation strategies (RIS3) of related regions, the (complementary) strengths and institutional (strategic) interests of its full members and in line with European priorities, missions and policy objectives, E<sup>3</sup>UDRES<sup>2</sup> 2.0 further develops and supplements these Research Networks into four future-guiding Focus Areas:

- (1) Health, Wellbeing and Social Inclusion for Regions;
- (2) Digital Solutions and (Applied) Deep Tech for Regions;
- (3) Resilient Economy and Innovation for Regions;
- (4) Creative Industries for Region's Identity.

These Focus Areas constitute a development of the existing Research Networks, in that they stronger integrate not only research but also education and innovation activities on specific thematic areas based on the needs of the regions and on the main societal and economical challenges and convey efforts and developments along main common paths – be it education-related activities, RDI undertakings, excellence initiatives or innovation pools.

## Results

E<sup>3</sup>UDRES<sup>2</sup> 2.0 measures progress with a set of 20 Core-KPIs and target values that include 50.000 benefitting students, 360 E<sup>3</sup>UDRES<sup>2</sup> labelled and 20 jointly developed learning activities, 50 associated startups/spin-offs, 200 solutions to regional challenges, 70 services for/with society and 450 submissions to **E<sup>3</sup>UDRES<sup>2</sup> awards of excellence**.

The kick-off meeting of the project took place in St. Pölten University of Applied Sciences, on 27-30 November 2023 and hosted an Executive Board meeting, a Board of Coordinators meeting, Students Representative Board meeting, as well as starting meetings on all work packages. Some panel discussions have been organized on topics like: Future Learning Models for Society, Micro-credentials and Future mobilities.

## Applicability and transferability of the results

E<sup>3</sup>UDRES<sup>2</sup> 2.0 also integrates HEIs from Western Balkans and Ukraine as associated partners in order to establish an enhance partnership and to successfully transfer project's results:

- University of Shkoder Luigj Guraku (USLG) / Albania
- University of Applied Sciences in Ferizaj (UASF) / Kosovo
- Aleksander Moisiu University of Durrës (AMUD) / Albania
- Bohdan Khmelnytsky National University at Cherkasy (BKNUC) / Ukraine
- Cherkasy State Business College (ChSBC) / Ukraine
- Sumy State University (SSU) / Ukraine

The project also aims to develop further co-operation applications under Horizon Europe, Erasmus+ KA2, Marie Curie doctoral consortiums and other international funded calls.

## Financed through/by

European Commission, ERASMUS-EDU-2023-EUR-UNIV

## Research Team

### Project director:

- Assoc. Prof. Dr. Eng. Florin DRĂGAN

### Project coordinator:

- Prof. Dr. Eng. Radu VASIU

### Researchers:

- Prof. Dr. Eng. Liviu MARȘAVINA
- Assoc. Prof. Dr. Eng. Vlad MIHĂESCU
- Assoc. Prof. Dr. Eng. Diana ANDONE
- Assoc. Prof. Dr. Eng. Attila SIMO
- Prof. Dr. Eng. Claudiu ALBULESCU
- Assoc. Prof. Dr. Eng. Loredana STANCIU
- Assist. Prof. Dr. Eng. Cristian ȚECU
- Assoc. Prof. Dr. Arh. Cristina POVIAN
- Lect. Dr. Eng. Mihaela CRIȘAN-VIDA
- Assoc. Prof. Dr. Eng. Valentin CIUPE
- Assist. Prof. Dr. Eng. Natalia RUDENKO
- Lect. Dr. Eng. Andrei TERNAUCIUC
- Assoc. Prof. Dr. Eng. Silviu VERT
- Prof. Dr. Eng. Dorin LELEA
- Lect. Dr. Eng. Florin VILCEA
- Assoc. Prof. Dr. Eng. Valentin NIȚĂ
- Prof. Dr. Eng. Anca DRAGHICI
- Assoc. Prof. Dr. Mat. Liviu CĂDARIU-BRĂILOIU
- Assoc. Prof. Dr. Eng. Simon PESCARI
- Assoc. Prof. Dr. Eng. Andrei CRISAN
- Assoc. Prof. Dr. Eng. Adrian DOGARIU
- Eng. Alexandru LUCA
- Assoc. Prof. Dr. Eng. Muguras MOCOFAN
- Prof. Dr. Eng. Sorin HERBAN
- Prof. Dr. Eng. Daniel DAN
- Prof. Dr. Eng. Sorin MUSUROI
- Dr. Ec. Roxana SÎRBU
- Maria MARITESCU
- Stud. Paul STIEGELBAUER
- Florin CIOCAN, external advisor



## Contact information

Prof. Dr. Eng. Radu VASIU, Faculty of Electronics, Telecommunications and Information Technologies, Department of Communications, Address: Victoriei Square, no.2, 300006, Timisoara  
Phone: (+40) 256 403 324  
Mobile: (+40) 722 516 555  
E-mail: radu.vasiu@upt.ro  
Project Website: <https://eudres.eu>



## E<sup>3</sup>UDRES<sup>2</sup> ENT-R-E-NOVATORS – BRIDGING THE GAP BETWEEN ENTREPRENEURS, RESEARCHERS, EDUCATORS AND INNOVATORS

### Goal of the project

E<sup>3</sup>UDRES<sup>2</sup> Ent-Re-Novators project aims to co-create a more specific joint research and innovation strategy and a common agenda to accelerate the transformation into a European multi-institutional Research and Innovation Hub for Smart and Sustainable Regions. The project includes, interacts and collaborates with a diverse variety of smart and ambitious people, academic institutions, regional authorities, companies, European R&I networks and regional innovation ecosystems. It is committed to scientific excellence and research integrity and promotes (future) R&I competences, skills, resources, methods, training, services and management for collaborative research and open innovation.

### Short description of the project

The project develops support for enabling scientific communities to fully embrace OS, OI, OE, Engaged Science and Education. E<sup>3</sup>UDRES<sup>2</sup> Ent-r-e-novators seeks to transform the region into a center of excellence in R&I.



### Project implemented by

**Coordinator:** Polytechnic Institute of Setúbal, Portugal

#### Partners:

- Politehnica University Timisoara, Romania
- St. Pölten University of Applied Sciences, Austria
- Hungarian University of Agriculture and Life Sciences, Hungary
- UC Leuven-Limburg University of Applied Sciences, Belgium
- Vidzeme University of Applied Sciences, Latvia

### Implementation period

01.10.2022 – 30.09.2025

### Main activities

The future of Europe requires knowledge and scientific culture, access to open science and education as an unalienable right for all. The project aims to develop the E<sup>3</sup>UDRES<sup>2</sup> R&I dimension, by employing innovative methodologies and environments. Ent-r-e-novators set itself six objectives to reach:

1. Co-create a common strategy to unlock the potential for excellence in R&I
2. Develop best practices for sharing research infrastructures, expertise, data and resources
3. Develop structured support to empower scientific communities to fully embrace OS, OI, OE, Engaged Science and Education
4. Achieve institutional strategies for Human Resources for Research, to address challenges such as brain mobility and new career assessment

5. Develop a framework to link all our R&I ecosystems and the E<sup>3</sup>UDRES<sup>2</sup> alliance's knowledge triangle of education, research and innovation

6. Build a common R&I agenda with peer Alliances and HEIs, HEI associations, advocacy groups, and policy-makers

### Results

On 9-10 March 2023 took place the second General Assembly meeting of the Ent-r-e-novators project at St. Pölten University of Applied Sciences, Austria (STPUAS), where the work teams presented their view for the implementation of the following transformation modules:

- Co-creation of a common strategy and agenda to accelerate the transformation into a European Research and Innovation Center
- Enabling scientific communities to fully embrace Open Science, Open Innovation, Open Education, Engaged Science and Engaged Education
- Development of institutional strategies and policies for Human resources for Research

On 5-6 October 2023 took place the third General Assembly meeting of the Ent-r-e-novators project in Gödöllő, Hungary, hosted by the Hungarian University of Agriculture and Life Sciences. The implementation results on each work package have been discussed and preparations were made for submitting the project midterm report to the European Commission.

## Applicability and transferability of the results

Ent-r-e-novators promotes Open Science, Open Innovation, Open Publishing and Citizen Science for the benefit of all members of the community. This is already a transferable goal, that aims at the development of small and medium-sized cities and their rural environments into smart and sustainable regions.

The project aims to develop further co-operation applications under Horizon Europe, Erasmus+ KA2, Marie Curie doctoral consortiums and other international funded calls.

## Financed through/by

European Commission, Horizon Europe Program, HORIZON-WIDERA-2021-ACCESS-05

## Research Center

Research Center for Multimedia



## Research Team

### Project leader:

- Prof. Dr. Eng. Radu VASIU

### Researchers:

- Assoc. Prof. Dr. Eng. Florin DRĂGAN

- Prof. Dr. Eng. Liviu MARȘAVINA

- Assoc. Prof. Dr. Mat. Liviu CĂDARIU-BRĂILOIU

- Prof. Dr. Eng. Daniel DAN

- Prof. Dr. Eng. Sorin MUȘUROI

- Assoc. Prof. Dr. Eng. Diana ANDONE

- Lecturer Dr. Eng. Vlad MIHĂESCU

- Assoc. Prof. Dr. Eng. Silviu VERT

- Assoc. Prof. Dr. Eng. Muguraș MOCOFAN

- Lecturer Dr. Eng. Andrei TERNAUCIUC

- Prof. Dr. Ec. Claudiu ALBULESCU

- Prof. Dr. Eng. Sorin HERBAN

- Prof. Dr. Eng. Alina DUMITREL

- Dr. Ec. Roxana SÎRBU

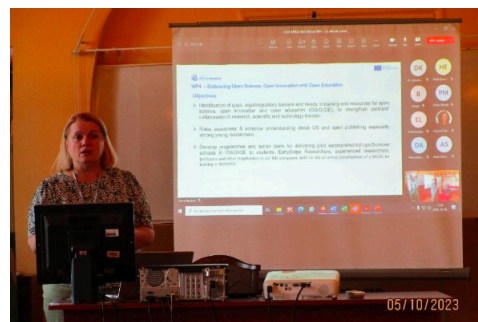

## Contact information

Prof. Dr. Eng. Radu VASIU, Faculty of Electronics, Telecommunications and Information Technologies,

Department of Communications

Address: Victoriei Square, no.2, 300006, Timisoara

Phone: (+40) 256 403 324

Mobile: (+40) 722 516 555

E-mail: radu.vasiu@upt.ro

Project Website: <https://eudres.eu/entrenovators>

## E<sup>3</sup>UDRES<sup>2</sup> ENTREPRENEURSHIP AND INNOVATION NETWORK FOR SMART AND SUSTAINABLE EUROPEAN REGIONS – E.I.N.S.

### Goal of the project

The E<sup>3</sup>UDRES<sup>2</sup> Entrepreneurship and Innovation Network for Smart and Sustainable European Regions (E.I.N.S.) co-ideates novel pathways for entrepreneurial universities, drives the development of entrepreneurial education, co-creates advanced support for innovation and business creation, and enhances collaboration across the knowledge triangle beyond the state of the art. As a project of the E<sup>3</sup>UDRES<sup>2</sup> alliance, the actors collaborating in E.I.N.S. comprise the six E<sup>3</sup>UDRES<sup>2</sup> founding institutions, as well as the University Industry Innovation Network (UIIN).

## E.I.N.S.

E<sup>3</sup>UDRES<sup>2</sup> Entrepreneurship and Innovation Network  
for Smart and Sustainable European Regions



### Short description of the project

E.I.N.S. is based on three pillars:

- Novel Pathways for Entrepreneurial Universities
- Support of Startups & established businesses
- Facilitation of collaboration across the knowledge triangle beyond the state of the art

### Project implemented by:

**Coordinator:** St. Pölten University of Applied Sciences, Austria

#### Partners:

- Politehnica University Timisoara, Romania
- Polytechnic Institute of Setúbal, Portugal
- Hungarian University of Agriculture and Life Sciences, Hungary
- UC Leuven-Limburg University of Applied Sciences, Belgium
- Vidzeme University of Applied Sciences, Latvia

### Implementation period

01.10.2021 – 30.12.2023

### Main activities

In order to further develop and strengthen innovation capacity, E.I.N.S. defines four long-term strategic priorities:

1. **Empower and support „Ent-r-e-novators“** to bridge the gaps within the knowledge-triangle
2. **Enhance entrepreneurial education to enable** learner-driven innovation
3. **Link** smart specialization and open innovation **to** connect regional ecosystems **with** Pan-European networks
4. Provide expertise and resources **to turn ideas into value** for smart and sustainable European regions

The projects' work packages are:

- WP1:** Management & Dissemination
- WP2:** Entrepreneurial Universities & Innovation Policies
- WP3:** (Open) Innovation and Entrepreneurship
- WP4:** Connected Research & Innovation
- WP5:** Networked Innovation Ecosystems & OI-Hubs
- WP6:** Continuous Coaching and Training on staff level in R&I Skills
- WP7:** Entrepreneurial Education
- WP8:** Support Innovation and Business Creation

### Results

E.I.N.S. developed methodologies and pilot activities to support international R&I collaboration:

- Knowledge database for entrepreneurial HEIs
  - Innovation foresight report
  - Comparative analysis of accessible E&I expertise
  - Structured pool of resources for innovation
  - Regional innovation ecosystem map
  - Open Innovation Hubs Co-creation methodology
  - Creation of a Network of OI-Hubs
  - Up-dated pool of coaches, trainers and mentors
  - Structural pool of entrepreneurial education inside the EUDRES alliance
  - Comparative analysis of Open Entrepreneurial Innovation
- 6 created Open Innovation Hubs:
- Agrifood
  - Digital Health & Social Innovation
  - Creative Industries & Digital Media
  - Digital Technologies and Advanced Manufacturing (hosted by UPT)
  - Smart and Sustainable Working and Learning Environments
  - Smart and Sustainable Cities, Regions and Villages

8 Open Lectures have been run by UPT on topics related to Open Innovation Hubs, Open Research and Open Innovation.

## Applicability and transferability of the results

E.I.N.S. promoted and disseminated the practical results and gained experience through a series of Open Lectures delivered both face-to-face and online for a large audience.

The results have been transferred between partner universities. They are also promoted and made available for the three new members of the EUDRES alliance, from the Netherlands, Germany and Finland.

## Financed through/by

European Institute of Innovation and Technology HEI Initiative, through EIT RawMaterials

## Research Center

Research Center for Multimedia



## Research Team

### Project leader:

- Prof. Dr. Eng. Radu VASIU

### Researchers:

- Assoc. Prof. Dr. Eng. Florin DRĂGAN

- Prof. Dr. Eng. Liviu MARȘAVINA

- Prof. Dr. Eng. Daniel DAN

- Assoc. Prof. Dr. Eng. Diana ANDONE

- Lecturer Dr. Eng. Vlad MIHĂESCU

- Lecturer Dr. Eng. Valentin NIȚĂ

- Assoc. Prof. Dr. Eng. Silviu VERT

- Prof. Dr. Eng. Carmen ALIC

- Prof. Dr. Eng. Anca DRĂGHICI

- Prof. Dr. Eng. George DRĂGHICI

- Prof. Dr. Eng. Dan LASCU

- Assoc. Prof. Dr. Eng. Razvan BOGDAN

- Lecturer Dr. Eng. Alina BĂLĂ

- Lecturer Dr. Eng. Andrei TERNAUCIUC

- Dr. Ec. Roxana SÎRBU

- Msc. Student Alexandru ILIESCU

- External expert Marius POPA



## Contact information

Prof. Dr. Eng. Radu VASIU, Faculty of Electronics, Telecommunications and Information Technologies, Department of Communications

Address: Victoriei Square, no. 2, 300006, Timisoara

Phone: (+40) 256 403 324

Mobile: (+40) 722 516 555

E-mail: radu.vasiu@upt.ro

Project Website: <https://eudres.eu/eins>

## EBSI4RO – CONNECTING ROMANIA THROUGH BLOCKCHAIN



### Goal of the project

The scope of the “EBSI4RO: Connecting Romania through Blockchain” project is to create an extendable and sustainable ecosystem to facilitate and accelerate the awareness, knowledge, and adoption of the **European Blockchain Services Infrastructure (EBSI)** by the Romanian citizens, businesses, institutions, and administration. It will also support the participation and contribution of Romania to the EBSI, in particular as regards the Diplomas use case.

As a result of the project, the Romanian educational system will be connected to the network of 41 European EBSI nodes and will be part of the European infrastructure.

### Short description of the project

The project aims to set the first EBSI node in Romania, to deploy the Diplomas’ use-case (applications and services for digital credentials and micro-credentials) and to support capacity building and training for universities.

### Project implemented by:

#### Coordinator:

Executive Agency for Higher Education Research, Development and Innovation Funding (UEFISCDI)

#### Partners:

Politehnica University Timisoara, Romania

### Implementation period

01.04.2021 – 31.03.2023

### Main activities

The project covers:

1. EBSI infrastructure development and operations : setup and operation of a Romanian EBSI node, integrated to EBSI network
2. EBSI cross-border use cases : deployment of the Diplomas, digital credentials and micro-credentials, integration with the National Student Enrolment Registry. The Credentialing System will issue on Blockchain (EBSI) the diplomas managed by the RMU operated by the Executive Agency for Higher Education, Research, Development and Innovation Funding (UEFISCDI)
3. EBSI capacity building and training activities for universities, through the creation of MOOCs for online and blended learning on the UniCampus (<https://unicampus.ro/>) platform, hosted by UPT.

### 4. Communication and blockchain community strengthening in Romania

The rollout of the EBSI will be supported in Romania, allowing the delivery of cross-border public services based on blockchain and enhancing the way citizens, government and businesses interact.

### Results

Successful demonstration of the first use case on delivering a university diploma by using the EBSI infrastructure, on 31 May 2022, as part of the EBSI Demo Day. The diploma was issued for one UPT graduate and was validated by the EBSI nodes in Greece and France. Romania is one of the first 12 countries in Europe that are delivering diplomas through the European Blockchain Services Infrastructure (EBSI).

UniCampus hosts 5 MOOC training modules:

- Blockchain technologies. Possible applications in Education;
- EU priorities and programs. EBSI services;
- EBSI open technical specifications. EBSI Use cases;
- How to test EBSI functionality and how to deploy applications;
- Developing DApps on EBSI for different use-cases.

**EBSI4RO** was mentioned in the country report Digital Economy and Society Index, as example of digitalisation.

**EBSI4RO** has been presented at the Bloxberg meeting in October 2022, in Cyprus, and UPT became a member of the Bloxberg Association for the Advancement of Science and Blockchain.

## Applicability and transferability of the results:

EBSI4RO is considered as a pilot project in the field of using blockchain technologies in education. Its results will allow generalization of:

- Delivery of higher education degrees through a credible and verifiable European infrastructure
- Validation of micro-credentials offered by different universities
- International validation of joint courses offered by consortium of universities
- Validation of acquired competence through different levels of education.

## Financed through/by

European Commission, Innovation and Networks Executive Agency (INEA)

## Research Center

Research Center for Multimedia

## Research Team

### Project leader:

- Prof. Dr. Eng. Radu VASIU

### Researchers:

- Assoc. Prof. Dr. Eng. Diana ANDONE

- Prof. Dr. Eng. Carmen HOLOTESCU

- Lecturer Dr. Eng. Andrei TERNAUCIUC

- Drd. Eng. Victor HOLOTESCU

- Assoc. Prof. Dr. Eng. Gabriela GROSSECK



Partner universities in the EBSI network

## Contact information

Prof. Dr. Eng. Radu VASIU, Faculty of Electronics, Telecommunications and Information Technologies,

Department of Communications

Address: Victoriei Square, no.2, 300006, Timisoara

Phone: (+40) 256 403 324

Mobile: (+40) 722 516 555

E-mail: radu.vasiu@upt.ro

Project Website: <https://ebsi4ro.ro/>

## EBSI-NE – DEPLOYMENT OF EBSI PRODUCTION NODES AND PROVISION OF SUPPORT SERVICES TO EBSI NETWORK AT THE EUROPEAN LEVEL



### Goal of the project

The **EBSI-NE project** is a collaborative initiative between 24 organisations from 14 European countries, all renowned for their expertise in Distributed Ledger Technologies and previous EBSI initiatives. The central mission of the project is to fortify the European Blockchain Services Infrastructure (EBSI) network by adding 18 new validator nodes to the production network and delivering comprehensive support services to all EBSI relevant stakeholders. By strengthening the EBSI network and providing essential support services, **EBSI-NE** is helping to accelerate the adoption of blockchain technology across Europe.

### Short description of the project

The objective of **EBSI-NE** is to support the development and adoption of the EBSI network at European level by increasing the number of validating nodes in the production network and by providing assistance services for all EBSI stakeholders.

### Project implemented by:

#### Coordinator:

Ministerio de Asuntos Economicos y Transformacion Digital (SGAD), Spain

#### Partners:

Politehnica University Timisoara, Romania

UEFISCDI Romania

TU Delft, Netherlands

Other 20 organizations from 14 European countries

### Implementation period

01.05.2023 – 30.04.2025

### Main activities

Activities include tasks to deploy an EBSI production node and other voluntary actions: integration of SIEM tools, development of tailored tests to improve robustness, development of framework to qualify EBSI nodes as trusted e-ledgers for eIDAS 2.

The projects' work packages are:

**WP1** – Management

**WP2** – Deployment of EBSI node

**WP3** – Support services to EBSI

**WP4** – Communication & dissemination

### Activities related to WP2:

- Prepare the infrastructure that meets EBSI Node Operator policy requirements and follows the EBP policy
- Deploy and configure EBSI node software package
- Perform infrastructure tests to ensure reliability and security

### WP3 related activities:

- Create technical competence centers at national level
- Provide security support services
- Create tools to improve the node operation lifecycle
- Organize online technical trainings
- Asses EBSI Network initiatives at national level
- Definition of methodology and approach to qualify EBSI validator nodes as e-ledgers for eIDAS2

### Results

**EBSI-NE** will provide 18 EBSI production validator nodes and additional support services to contribute towards the deployment and extension of the EBP use cases.

Regional technical and security services will be provided, which are estimated to be up and running as soon as a node is deployed in the network.

In order to increase the security of the EBSI network as well as its resilience and performance, the project will set-up and integrate with the node a Security Information and Event Management (SIEM) tool. Other support services to improve resilience, performance, robustness, security and sustainability of the EBSI network: delivery of EBSI trainings, development of technical tools to support future node operators, reports to cover possible synergies between EBSI and national blockchain initiatives.

## Applicability and transferability of the results:

The project is strongly aligned to the EU's long term digital policies and blockchain strategy. It will help establish the required infrastructure for the expansion and adoption of blockchain technology, one of the key digital technologies prioritized by the European Commission to increase the digitalization of the European society.

The consortium groups organizations from 14 EBP members to collaborate on the development of this infrastructure, avoiding fragmentation of the blockchain landscape in Europe. Active cooperation between the participants is sought to create and monitor a blockchain network that promotes a more secure and interoperable infrastructure, further developing the baseline objectives established in the EU blockchain strategy.

## Financed through/by

Digital Europe Programme

DIGITAL-2022-DEPLOY-02

European Commission,

European Health and Digital Executive Agency (HADEA)

## Research Center

Research Center for Multimedia

## Research Team

### Project leader:

- Prof. Dr. Eng. Radu VASIU

### Researchers:

- Assoc. Prof. Dr. Eng. Diana ANDONE

- Prof. Dr. Eng. Carmen HOLOTESCU

- Lecturer Dr. Eng. Andrei TERNAUCIUC

- Drd. Eng. Victor HOLOTESCU

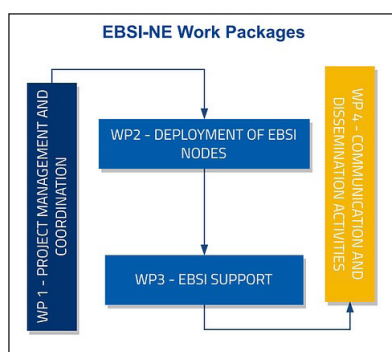

EBSI-NE Roadmap

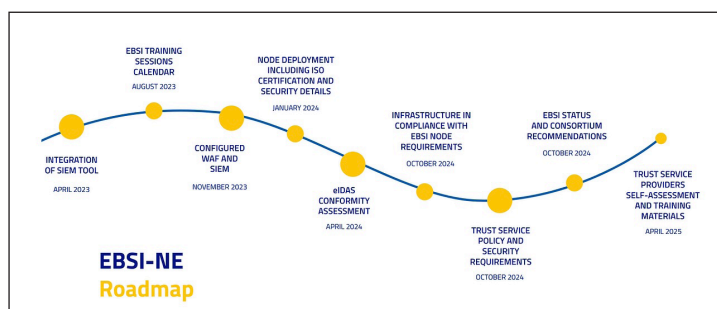

EBSI-NE Roadmap

## Contact information

Prof. Dr. Eng. Radu VASIU, Faculty of Electronics, Telecommunications and Information Technologies, Department of Communications  
 Address: Victoriei Square, no.2, 300006, Timisoara  
 Phone: (+40) 256 403 324  
 Mobile: (+40) 722 516 555  
 E-mail: radu.vasiu@upt.ro  
 Project Website: <https://www.ebsi-ne.com/>



## EBSI-VECTOR – EBSI ENABLED VERIFIABLE CREDENTIALS & TRUSTED ORGANISATIONS REGISTRIES



### Goal of the project

EBSI-VECTOR brings the power of the self-sovereign identity paradigm to the educational and social security context. Defining and implementing the strategy for expanding EBSI capabilities in different countries is essential.

The project provides the necessary basic elements and tools for citizens and organizations to interact with each other through verifiable credentials and to use the confidentiality-based verification power of the EBSI decentralized trust registers.

The project is part of an extended ecosystem with other EU projects and initiatives (ESSPASS, EHIC, EUROPASS).

### Short description of the project

EBSI-VECTOR contributes to Digital transformation in specific areas (educational credentials, social security) at EU level through blockchain technologies.

### Project implemented by:

#### Coordinator:

Engineering - Ingegneria Informatica SPA (ENG), Italy

#### Partners:

Politehnica University Timisoara, Romania

UEFISCDI Romania

Alma Mater Studiorum – Universita di Bologna (UNIBO), Italy

KU Leuven, Belgium

Université de Lille, France

Other 47 organizations from 20 European countries

### Implementation period

01.06.2023 – 31.05.2025

### Main activities

The consortium formed by 52 partners from 20 countries strengthens the current capabilities of EBSI regarding verifiable accreditations and trust registers and expands them with new capabilities such as the decentralized identity of legal entities or the revocation functionality. The project partners will transform the digital interaction of citizens studying and working in Europe and will simplify some of the complex verification processes for organizations in a decentralized way.

EBSI-VECTOR project work packages are:

**WP1** – Project Management and Coordination

**WP2** – Strategizing for scaling up, take-up, and interoperability of EBSI use cases

**WP3** – European Self Sovereign Identity Framework (ESSIF) specifications and building blocks

**WP4** – Education Use Case

**WP5** – Social Security Use Case

**WP6** – Ecosystem building, policy support and sustainability

**WP7** – Dissemination, communication and visibility

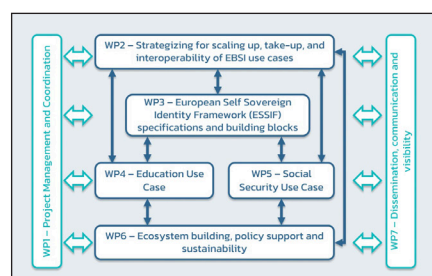

EBSI – VECTOR WPs

### Results

The project partnership started working on different Use Cases on the following topics:

- Education
- Social security
- Business registries

UPT is interested and involved in educational applications and in providing training for those skills.

This use case is performed from WP4, and aims to implement new

and current EBSI capabilities through a two-phase approach. The first phase will be focused on implementing current EBSI capabilities and the second one will address new EBSI capabilities. This use case is based on EBSI Diploma use case specifications. At the end, several cross - border journeys for educational capabilities will be deployed. EBSI-VECTOR received the prize under “Public Sector Innovation” category at the INATBA Awards Gala in Autoworld Brussels.

## Applicability and transferability of the results:

EBSI-VECTOR contributes to the following long-term EU policy objectives, ensuring results’ transferability:

- Building a pan-European public services blockchain
- Promoting legal certainty, by compliance with eIDAS
- Increasing funding for research and innovation through
  - (i) efforts for scalability
  - (ii) building strong ecosystem with other digital technologies.
- Promoting blockchain for sustainability by reducing the environmental footprint
  - (i) directly – through decentralized solutions
  - (ii) indirectly – through optimization of cross border services interoperability
- Supporting interoperability and standards
- Interacting with community through the creation of future governance framework for EU digital consortium for Blockchain



## Financed through/by

Digital Europe Programme  
DIGITAL-2022-DEPLOY-02  
European Commission,  
European Health and Digital Executive Agency (HADEA)

## Research Center

Research Center for Multimedia

## Research Team

### Project leader:

- Lecturer Dr. Eng. Andrei TERNAUCIUC

### Researchers:

- Prof. Dr. Eng. Radu VASIU
- Assoc. Prof. Dr. Eng. Diana ANDONE
- Prof. Dr. Eng. Carmen HOLOTESCU
- Drd. Eng. Victor HOLOTESCU

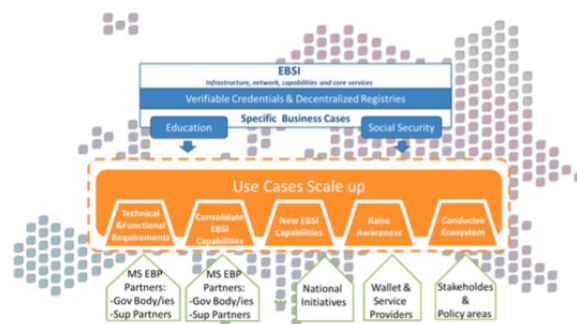

## Contact information

Lecturer Dr. Eng. Andrei TERNAUCIUC, Faculty of Electronics, Telecommunications and Information Technologies, Department of Communications  
Address: Bd. Vasile Parvan, no.2, 300223, Timisoara  
Mobile: (+40) 726 410467  
E-mail: andrei.ternauciuc@upt.ro  
Project Website: <https://www.ebsi-vector.eu/en/>

## DC4EU – DIGITAL CREDENTIALS FOR EUROPE



### Goal of the project

The **DC4EU project** will focus on the identification and application of all necessary measures to facilitate the issuance of educational credentials and professional qualifications in the Education sector, as well as the issuance of the portable document A1 (PDA1) and the European Health Insurance Card in the Social Security sector. The European digital identity wallet will be a key element of hybridization for cross-sectoral and cross-border use cases (identity, signature, educational credentials and social security).

### Short description of the project

**DC4EU** focuses on identifying and applying Digital Europe aspects in education: issuance of educational credentials and professional qualifications by engaging in the execution of the portable document A1 (PDA1).

### Project implemented by:

#### Coordinator:

Ministerio de Asuntos Economicos y Transformacion Digital (SGAD), Spain

#### Partners:

Politehnica University Timisoara, Romania

UEFISCDI Romania

CertSIGN, Romania

Other 77 organizations from 23 European countries

### Implementation period

01.04.2023 – 31.03.2025

### Main activities

The projects' work packages are:

**WP1:** Project Management and Coordination

**WP2:** Analysis, Planification and Design

**WP3:** Collaboration and Alignment

**WP4:** Onboarding Base Identity

**WP5:** The Education Domain

**WP6:** The Social Security Domains

**WP7:** Integrations and Development

**WP8:** Ecosystem building & policy support

**WP9:** Communications & Dissemination

UPT is mainly interested in WP5, regarding educational applications. This includes onboarding procedures, identifying educational requirements, implementing interfaces for credential issuers, comprehensive process testing of the systems and evaluation of processes.

The European Digital Identity Wallet (EUDIW) will be a fundamental element of hybridization for cross-sectoral and cross-border use cases (identity, signature, educational credentials).

**DC4EU** contributes to a new paradigm for citizens in the field of education, which is fully aligned with the European Council requirements for identity and data.

### Work Packages (WP)

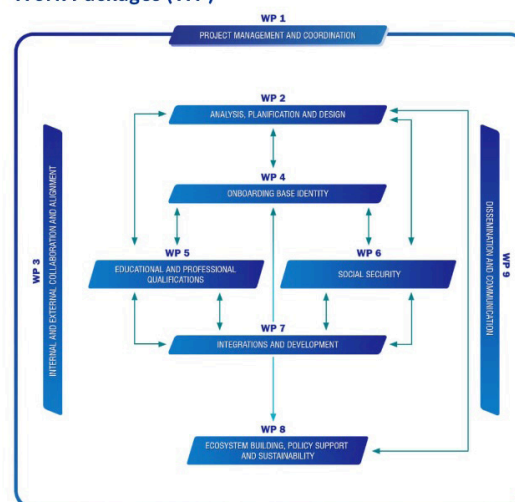

### Results

The **outcomes of DC4EU** will build upon large-scale pilots focusing on education and professional credentials.

The Architecture Reference Framework and the wallet reference implementation are in progress.

The project is aligned with the EU Digital Strategy, EU Data Strategy, EBSI framework, eIDAS Trust and GDPR.

The basis is used data models (European Learning Model – ELM), existing EBSI framework, OTSS, EU strategies, and ongoing initiatives such as EWP, eduGAIN, Europass and European Universities initiative. The work related to education consists in designing and implementing educational credentials and professional qualifications. This will include onboarding customisation and execution, interoperability of preliminary tasks and identification of opportunities and synergies with domain-related activities.

### Applicability and transferability of the results:

The project develops digital transformation in education based on trusted registries, onboarding management for wallet users and support for process execution.

The project completes comprehensive testing of defined cross-border journeys in a pre-production environment of the target systems while coordinating with other ongoing cross-border initiatives and synergies with other educational-related activities: related DGs (H4, F3, EAC, EMPL), EU, and Key education players. That's why DC4EU will be a catalyst for innovation in education identification requirements and will assist the evolution process from the traditional identification to a reliable digital identity.

The level of standardization ensures transferability of results to any interested actor.

### Financed through/by

Digital Europe Programme  
DIGITAL-2022-DEPLOY-02  
European Commission,  
European Health and Digital Executive Agency (HADEA)

### Research Center

Research Center for Multimedia

### Research Team

#### Project leader:

- Assoc. Prof. Dr. Eng. Diana ANDONE

#### Researchers:

- Prof. Dr. Eng. Radu VASIU

- Prof. Dr. Eng. Carmen HOLOTESCU

- Lecturer Dr. Eng. Andrei TERNAUCIUC

- Drd. Eng. Victor HOLOTESCU

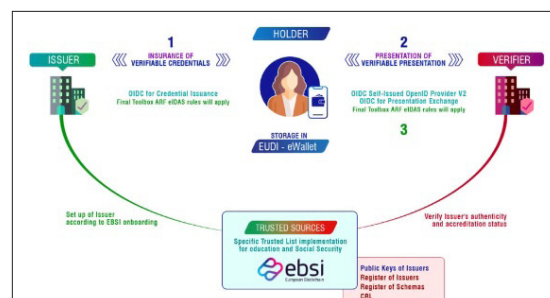

### Contact information

Dr. Eng. Diana ANDONE  
Digital Education Department  
Address: Bd. Vasile Parvan, nr. 2B, 300223 Timisoara  
Phone: (+40) 256 403300  
Mobile: (+40) 722 457224  
E-mail: [diana.andone@upt.ro](mailto:diana.andone@upt.ro)  
Project Website: <https://www.dc4eu.eu/>

## ACCELERATE\_FUTUREHEI – ENTREPRENEURIAL & INNOVATIVE UNIVERSITIES ACCELERATION PROGRAMME



### Goal of the project

Higher Education Institutions can positively impact regional and Europe-wide social and economic development through education, research and engagement. However, they require targeted support to enhance their capability to fully realise their potential.

Accelerate Future HEI will develop and test acceleration services, to equip HEIs with the skills and capacity to drive institutional transformation towards becoming more entrepreneurial and innovative institutions over the next four years.

### Short description of the project

HEIs are key drivers of knowledge and innovation ecosystems, but there is a clear need for a targeted support to realize this potential. The project develops and implements a methodology of change by embracing entrepreneurial, engaged, innovative and open spirit.

### Project implemented by:

**Coordinator:** University Industry Innovation Network (UIIN), Netherlands

#### Partners:

Politehnica University Timisoara, Romania  
St. Pölten University of Applied Sciences, Austria  
UC Leuven-Limburg University of Applied Sciences, Belgium  
Universidade da Madeira, Portugal  
Hungarian University of Agriculture and Life Sciences, Hungary  
Vidzeme University of Applied Sciences, Latvia  
Universidad Europea de Canarias, Spain  
Université de La Réunion, France  
Instituto Superior Tecnico Lisboa, Portugal  
TUM International GmbH, Germany  
Momentum Marketing Services Limited, Ireland

### Implementation period

01.01.2023 – 31.12.2026

### Main activities

Project work packages:

- WP1 – Management
- WP2 – Scanning & Scoping
- WP3 – Developing
- WP4 – Testing & Implementing
- WP5 – Capacity Building & Knowledge Exchange

WP6 – Monitoring & Evaluation

WP7 – Policy Feedback

WP8 – Quality Assurance

WP9 – Dissemination

The methodology is designed to build capacity within HEIs to enable them to pursue institutional transformations. The approach is based on a **gap-analysis**, that begins with understanding HEI's desired future / current state (WP2). HEIs are guided to identify the key challenges to be addressed via acceleration services and coaching activities, and develop a roadmap and implementation plan to achieve their desired institutional transformation, and identify the required acceleration services (WP3). Finally, acceleration services are tested within the HEIs to drive entrepreneurial and innovative change, supported by coaching, monitoring and evaluation (WP4).

### Results

The project provides open resources for European HEIs who are interested in transforming to build their capability to drive entrepreneurial change.

Up to the end of 2023, the following results have been shared:

- **Strategic vision statements** towards becoming Entrepreneurial and Innovative Universities
- **Synthesis Report:** Key findings based on a gap analysis, that begins with understanding the HEI's desired future and current state.

### Applicability and transferability of the results:

The aim of the project is to develop and test a methodology for acceleration services to support HEI institutional transformation, combining coaching services, investment strategy, quality and progress monitoring mechanism, followed by the widespread dissemination and policy feedback of the pilot test results.

The project has been designed using a Logic Model framework,

which aligns the aims of the project, with the activities (WPs), the outputs (deliverables), outcomes desired (benefits for the project target groups) and the long-term impacts.

By supporting transformation through university-industry cooperation, engagement, entrepreneurial and innovation spirit, the project ensures a practical transfer of knowledge to other interested institutions.

## Financed through/by

European Commission,  
Horizon Europe Program,  
HORIZON-WIDERA-2022-ERA-01

## Research Center

Department for Digital Education

## Research Team

### Project leader:

- Dr. Eng. Diana ANDONE

### Researchers:

- Prof. Dr. Eng. Radu VASIU

- Assoc. Prof. Dr. Eng. Vlad MIHĂESCU

- Assist. Prof. Drd. Maria-Elena BOATCĂ-BARABAȘ

- Dr. Ec. Roxana SÎRBU



## Key Objectives



### TO IDENTIFY

the **status quo** of the HEI and its ecosystem regarding entrepreneurial and innovative activities.



### TO DEVELOP

test and implement **acceleration services** that help institutions undertake a transformation roadmap and projects.



### TO BUILD

the capacity of the participating HEIs staff to implement the transformation roadmaps through a **skills development program**.



### TO EVALUATE

the strategies from HEIs supervised by an 'acceleration board' of **independent experts**.



### TO GENERATE

**policy feedback** to the European Commission as well as provide widespread dissemination of the pilot results to other target groups.

## Contact information

Dr. Eng. Diana ANDONE

Digital Education Department

Address: Bd. Vasile Parvan, no. 2B, 300223 Timisoara

Phone: (+40) 256 403300

Mobile: (+40) 722 457224

E-mail: [diana.andone@upt.ro](mailto:diana.andone@upt.ro)

Project Website: <https://acceleratefuturehei.eu/>

## CA20139 - HOLISTIC DESIGN OF TALLER TIMBER BUILDINGS (HELEN)

### Goal of the project

The main objective of the **HELEN COST Action** is to foster international interest and effort in developing a shared understanding and deriving common guidelines for the Holistic Design of taller timber buildings. The synergistic HELEN network is formed by a large group of experts from a wide field of the built environment sector, where researchers and industrial partners exchange knowledge and skills that have historically been isolated to individual research fields.

### Short description of the project

The **HELEN COST Action** will change the paradigm of building construction research, shifting R&D from isolated topics to an integrated interdisciplinary approach, which is critically necessary to safely design and build as well as correctly maintain and recycle taller timber buildings.

### Project implemented by:

Coordinator: COST Association AISBL

### Implementation period:

October 2021 – October 2025

### Main activities

The very essence and key to a successful **HELEN COST Action** will be intense interdisciplinary work with in-depth discussions and debate over a series of hypothetical and real case studies, followed by focused research work. Contrary to common building research work done in the past, where individual topics were assessed in depth by specialised teams working on isolated topics (i.e. just timber connections or just vibration of floor plates), research within the Action will be intensely collaborative and integrated.

The main activities are:

**EG 1: Timber Engineering.** This expert group will consist of members mastering fields of 1 timber structures, 2 timber connections, 3 fire behaviour, 4 seismic response, 5 wind response, 6 structural reliability, 7 robustness, 8 floor vibration, 9 maintenance, 10 disassembly, and 11 duration of load.

**EG 2: Computational Modelling.** This expert group will consist of members mastering fields of 1 fire spread modelling and 2 seismic modelling as well as 3 general finite element modelling.

**EG 3: Building Physics.** This expert group will consist of members mastering fields of 1 acoustics, 2 volatile organic compounds, 3 indoor air quality and 4 thermal behaviour.

**EG 4: Architecture.** This expert group will consist of members mastering fields of 1 architectural design, 2 room design, 3 facades and 4 urban planning.

**EG 5: Construction Management.** This expert group will consist of members mastering fields of 1 factory management, 2 construction site management, 3 logistics, 4 industrialization, 5 prefabrication and 6 waste management.

**EG 6: Material Science.** This expert group will consist of members mastering fields of 1 material production (engineered wood products), 2 adhesives, 3 coatings and 4 wood modification.

**EG 7: Human Health.** This expert group will consist of members mastering fields of 1 restorative design and 2 ergonomics.

**EG 8: Life Cycle Analysis.** This expert group will consist of members mastering fields of 1 life cycle analysis, 2 life cycle cost and 3 social life cycle analysis.

### Results

Until this point, the research teams were made, the working groups were established and the first common meeting was organized.

During this first meeting, there was made a state-of-the-art report, and the next research steps were established.

### Applicability and transferability of the results

One of the main motivations for establishment of the **HELEN COST Action** consortium is the current lack of an interdisciplinary international expert network that is able to merge and push forward the recent advancements in the various areas related to multi-storey timber design and construction, which have been treated individually due to their diverse specific scientific areas.

The advantage of the **COST Action** is that it provides a platform where the objectives will be dealt with in a holistic approach.

## Financed through/by

Horizon 2020 Framework Programme of the European Union

## Research Center

Research Center in Urban Planning and Architecture

## Research Team

### Project leader:

- Prof. Dr. Eng. Marius MOSOARCA (for Romanian team)

### Researchers:

- Lect. Dr. Eng. Mihai FOFIU
- Assist. Ph.D. Stud. Arch. Bogdan ISOPESCU
- Lect. Dr. Arch. Alexandra KELLER
- Lect. Dr. Arch. Iasmina ONESCU
- Lect. Dr. Arch. Cristina POVIAN
- Prof. Dr. Eng. Valeriu STOIAN

## Contact information

Prof. Dr. Eng. Marius MOSOARCA  
Faculty of Architecture and Town Planning  
Department of Architecture  
Address: 2A, Traian Lalescu Street, 300223, Timisoara  
Phone: (+40) 256 404 028  
Mobile: (+40) 740 612 757  
E-mail: marius.mosoarca@upt.ro  
Project Website: <https://cahelen.eu/about-us/>



## SBAS ADOPTION ON MULTI-COPTER VTOL AIRCRAFTS (SAMVA)

### Goal of the project

The **SAMVA project** will increase the adoption of EGNOS technology within the provision of rotorcraft services, and will pave the way towards seamless integration of VTOL autonomous aircraft, by means of:

- Achieve operational use of EGNOS within the provision of Helicopter Emergency Medical Services, by implementing first Point-in-Space and Low-Level-Route operation in Spain;
- Deploy first EGNOS VTOL operation at a European airport (LEDA), and demonstrate how EGNOS can support ATM tasks for entry into operations;
- Unleash EGNOS capabilities on-board a VTOL Autonomous Aerial Vehicle (AAV) (EHANG EH216) for the provision of precise and integer navigation guidance and support U-Space Airspace integration;
- Develop, in-flight test and validate, an EGNOS RNP flight procedure design criteria based on the specific navigation performance from an AAV passenger capable;
- Demonstrate how current EGNOS Safety-of-Life Service can best support VTOL urban operations by hybridizing data from on-board sensors;
- Evaluate how current EGNOS service could evolve to provide high accuracy integrity values in combination with the Galileo High Accuracy Service; and
- Promote the adoption of EGNOS services towards the provision of Urban Air Mobility services through the support of Stakeholders from different European cities and regions.

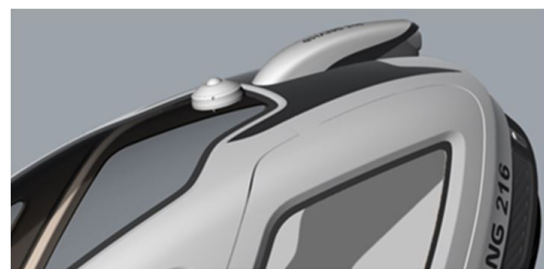

EH216-SAAV at Lleida–Alguaire International Airport, in October 2023 (left), fish eye camera installed on it (right)

### Short description of the project

- Based on the performance and integrity provided by EGNOS (European Geostationary Navigation Overlay Service), the safe integration of rotorcraft operations in all-weather conditions and obstacle-rich environments is now feasible through GNSS (Global Navigation Satellite System) RNP (Required Navigation Performance) instrumental procedures.

- However, although most recent helicopter units are already equipped to fly these types of procedures, today, Emergency Medical Services (EMS) air operations are mostly restricted in good weather and at daylight.
- Furthermore, the EGNOS integrity concept is inherited from the civil aviation domain, with very high confidence levels on the computed navigation position, and has the potential to enhance eVTOL (electric Vertical Take-Off and Landing) aircraft operations in Urban Air Mobility (UAM) environments.

- In this framework, SAMVA project intends to foster the adoption of EGNOS technology within the provision of rotorcraft and Advanced Air Mobility (AAM) services and U-space integration.

## Project implemented by:

**Coordinator:** Pildo Labs Barcelona – Spain

### Partners:

Ehang Technologies Spain & LATAM S.L. – Spain

Airport Regions Council – Belgium

Thales Alenia Space France – France

Eliance Helicopter Global Services S.L. – Spain

Aeroports Públics De Catalunya Slu – Spain

### Subcontractors:

Politehnica University Timisoara – Romania

## Implementation period:

03.10.2022–30.09.2024

## Main activities

- In collaboration with TAS-F, UPT will be in charge of processing the fish eye camera collected data / videos, and provide the needed outputs in terms of image segmentation and masking angles that are fed to the hybridization algorithm in order to detect and exclude multipaths.

## Results

- A formalized agreement was made between Aeroports de Catalunya and EHang for airport premises use, closely coordinating vertiport infrastructure requirements with AESA (Spanish Aviation Safety and Security Agency).
- The EH216 Navigation System was assessed to meet the project requirements. Two of the project's partners, EHang and Aeroports de Catalunya, organized the inauguration of the first EHang European UAM (Urban Air Mobility) Center in Spain, at Lleida–Alguaire International Airport.
- This center is the pioneering facility of its kind in Europe for unmanned eVTOL aircraft.
- A fish eye camera VIVOTEK FE9380-HV was installed on the AAV, permitting the collection of videos, besides the GNSS data.

## Applicability and transferability of the results

- Through the operational developments proposed, and the engagement with key stakeholders, SAMVA will be a key milestone for the adoption of EGNOS technology in present and future rotorcraft and eVTOL operations.

## Financed through/by

- EUSPA (European Union Agency for the Space Programme), granted under the call for proposals "GSA/GRANT/01/2021 – Acceleration of EGNOS Adoption in Transport".

## Research Center

Research Center for Intelligent Signal Processing (ISPRC)

<https://shannon.etc.upt.ro>

## Research Team

– **Project leader:** Prof. Dr. Eng. Corina NAFORNITA

### Researchers:

– Prof. Dr. Eng. Alexandru ISAR

– Lecturer Dr. Eng. Ciprian DAVID

## Contact information

Prof. Dr. Eng. Corina NAFORNITA

Faculty of Electronics, Telecommunications and Information Technologies

Department of Communications

Address: No. 2, Bd. Vasile Parvan, 300223, Timisoara

Phone: (+40) 256 403 318

Mobile: (+40) 722 782 359

E-mail: [corina.naforrita@upt.ro](mailto:corina.naforrita@upt.ro)

Project Website: <https://www.samva-project.eu/>

# PROJECTS SUPPORTED BY PRIVATE FUNDS



## TOPO GEODETIC MEASUREMENTS, LEVELING AND PLANIMETRY CARRIED OUT ON THE VĂLIUG, TIMIȘ, TREI APE, SECU AND GOZNA DAMS NECESSARY FOR THE PREPARATION OF THE U.C.C. REPORT

### Goal of the project

- The purpose of the project is to carry out topo-geodetic measurements for the dams: Văliug, Timiș-Trei Ape, Secu and Gozna in order to monitoring dams behavior.

### Short description of the project

- The purpose of the project is to carry out topo-geodetic measurements for the dams: Văliug, Timiș-Trei Ape, Secu and Gozna. The results of these measurements consist in determining the coordinates of some mobile planimetry benchmarks placed on the body of the dams to measure displacements and deformations. These measurements are both relative and absolute in nature. The relative character of the measurements corresponds to the situation when measuring the proximity or distance of two or more points subjected to measurements.
- The absolute character of the measurements corresponds to the situation when the displacements of these mobile benchmarks are measured in relation to fixed benchmarks. At the same time, through mobile leveling markers, it is possible to highlight subsidence, or downward vertical displacements, bulges or elevations that represent vertical upward displacements of constructions.

### Project implemented by

**Coordinator:** Politehnica University Timisoara

**Partners:**

TMK HIDROENERGY POWER S.R.L. Reșița

### Implementation period

24.04.2023 – 31.12.2025

### Main activities

- The actions that were taken to produce the proposed results within the project:
  - Moving to the objectives subject to monitoring through topographical measurements;
  - Design of the support network;
  - Checking the support network;
  - Inspecting and checking the state of the planimetry and leveling markers;
  - Checking the condition of the station points, the pilasters

### Results

- The results consist in the provision to the beneficiary of the tables with the coordinates of the mobile planimetry markers as well as the elevations for the mobile leveling markers located on the project's specific objectives.
- At the same time, these results are accompanied by graphs (displacement graph, leveling graph) to help their interpretation.

### Applicability and transferability of the results

From the problems that have been encountered over time, we can mention:

- The need for much more careful maintenance of the condition of the marks, both planimetry and leveling, in order to obtain the best possible results and which are affected as little as possible by errors;
- Correct maintenance and protection of pilasters, station points;
- Carrying out maintenance work on the dams so that the existing vegetation does not affect the visas to the marks on the body of the dams.
- The accuracy of determining the markers increases as the stations approach the object under measurement, up to an optimal distance, which if reduced further, the aiming errors increase greatly.

## Financed through/by

- TMK HYDROENERGY POWER S.R.L. Reșița

## Research Center

- Research Center for Hidrotechnical Engineering and Environmental Protection

## Research Team

- Project leader: Assoc. Prof. Dr. Eng. Gabriel ELEȘ



The position of the mobile planimetric markers for the downstream face of the SECU Dam



Crest of the GOZNA Dam, Caraș-Severin County



Carrying out topographical measurements for the SECU Dam, Caraș-Severin County



Leveling landmark, Breazova Dam, Caraș-Severin County

## Contact information

Assoc. Prof. Dr. Eng. Gabriel ELEȘ  
Faculty of Civil Engineering  
Department of Hydrotechnical Engineering  
No. 1/A, Spiru Haret Street, Timisoara  
Phone: (+40) 256 404093  
Mobile: 0765218299  
E-mail: gabriel.eles@upt.ro

## EXPERIMENTAL TESTING OF BUCKLING RESTRAINED BRACES FOR THE “MARIA SKLODOWSKA CURIE” CLINICAL HOSPITAL

### Goal of the project

The project aimed at qualifying experimentally the **buckling restrained braces (BRBs)**, adopted as the seismic protection system of the extension with a new building of the Clinical Emergency Hospital for Children “Maria Sklodowska Curie” in Bucharest, Romania.

### Short description of the project

- Buckling restrained braces (BRBs) are innovative structural components (devices) used for seismic energy dissipation and consisting of an axially yielding core and a decoupled restraining mechanism. The concept was developed in Japan, but the first BRBs were installed in the United States.
- CEMSIG Research Center had a pioneering role in implementing BRBs in Romania, by introduction of seismic design criteria in the P100-1/2013 code and, later, by development of a design procedure for BRBs and structural systems using such devices within the IMSER research project.
- Recently, the innovative structural system consisting of steel frames and buckling restrained braces (BRBs) was adopted for the extension with a new building of the Clinical Emergency Hospital for Children “Maria Sklodowska Curie” in Bucharest, Romania. Within the current project, four full-scale buckling restrained braces were experimentally qualified, as required by the P100-1/2013 and SR EN 15129 code provisions, in order to prove their performance under cyclic loading conditions.



### Project implemented by

- **Coordinator:** Politehnica University Timisoara

### Implementation period

- 21.06.2023-21.12.2023

### Main activities

The main activities carried on within this research project were:

- The design of the experimental setup based on execution drawings and technical documentation provided by the structural designer (Popp & Asociații);
- Carrying out experimental tests on the specimens manufactured by the Beneficiary (Kemfort Steel Ind);
- The analysis of experimental results and providing a final report on qualification of the buckling restrained braces.

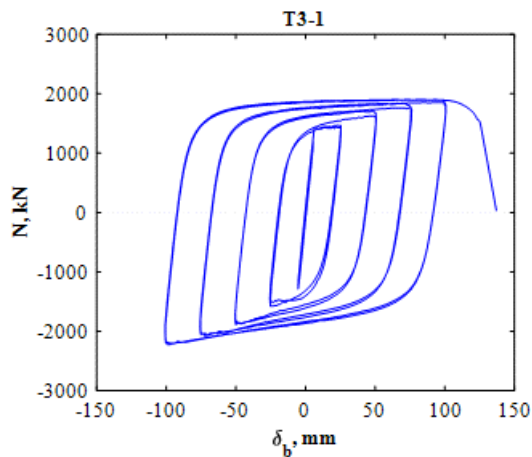

## Results

- The experimental results of cyclic tests carried out on investigated BRB specimens proved their ability to develop plastic deformations under the design seismic action, equal to twice the relative computational level displacement at the ultimate limit state ( $2,0 \cdot \delta_{bm}$ ), but not less than 0,02 of floor height, without loss of overall stability.
- The specimens also met the seismic prequalification criteria specified in ANSI/AISC code 341-22: axial force – deformation diagrams showing a stable, quasi-symmetric hysteretic response; BRBs demonstrated a stable behavior, without local failures in brace or joints; the maximum tensile and compression forces were within the code-required limits.

## Applicability and transferability of the results

- The project investigated the seismic performance of full-scale buckling restrained braces fabricated in “real-life” conditions, proving their fit-for-use in practice, for the extension with a new building of the Clinical Emergency Hospital for Children “Maria Sklodowska Curie” in Bucharest.
- The buckling restrained braces met the qualification requirements of P100-1/2013, and the safety and seismic performance of these anti-seismic devices was experimentally proved.
- It is worth mentioning that a strict control of the traceability of materials used in the manufacture of buckling restrained braces is necessary.

## Financed through/by

- Kemfort Steel Ind S.R.L.

## Research Center

- Research Center for Materials Mechanics and Structural Safety

## Research Team

Project leader: Prof. Dr. Eng. Aurel STRATAN

### Researchers:

- PhD Student Eng. Anna ENE
- Eng. Ovidiu ABRUDAN
- PhD Student Eng. Viktor SZALAI
- PhD Student Eng. Dominiq JAKAB
- Lecturer Dr. Eng. Călin NEAGU

## Contact information

Prof. Dr. Eng. Aurel STRATAN  
Faculty of Civil Engineering  
Department of Steel Structures and Structural Mechanics  
Address: 1 Ioan Curea street, 300224, Timisoara  
Phone: (+40) 0256 403 923  
Mobile: (+40) 0746 161 762  
E-mail: aurel.stratan@upt.ro



## CONTINUITY OF WORK PACKAGES DERIVED FROM CONTIVATION RISC-V FROM 2022 TO DS MATRIX BACKLIGHT ASIC 2023, REFERENCE INTEGRATION AND ICS DEMONSTRATORS FOR CONSUMER ELECTRONICS (CES) AND IAA FAIRS 2022 TO 2024

### Goal of the project

The main goal of our project is the implementation of new architectures based on RISC-V ISA for automotive algorithms in order to accelerate the hardware processing of specific automotive information.

### Short description of the project

The aspects we focus on in our project are the definition, implementation and validation of a set of hardware-optimized RISC-V architectures as well as their related peripherals. The implementations are optimized to reduce the power dissipation and to increase the flop/watt performance.

### Project implemented by:

μETM. Microelectronics Team – Timișoara,  
<https://uetm-team.upt.ro/>

### Implementation period

03.01.2023 – 15.11.2024

### Results

• One of the basic implementations designed in our project was a custom AXI4 Lite peripheral that allows writing and reading of certain registers. For this we used Zynq UltraScale+ MPSoC ZCU102 Evaluation Kit and Jupyter platform. The block diagram for our implementation and the obtained results are presented below:

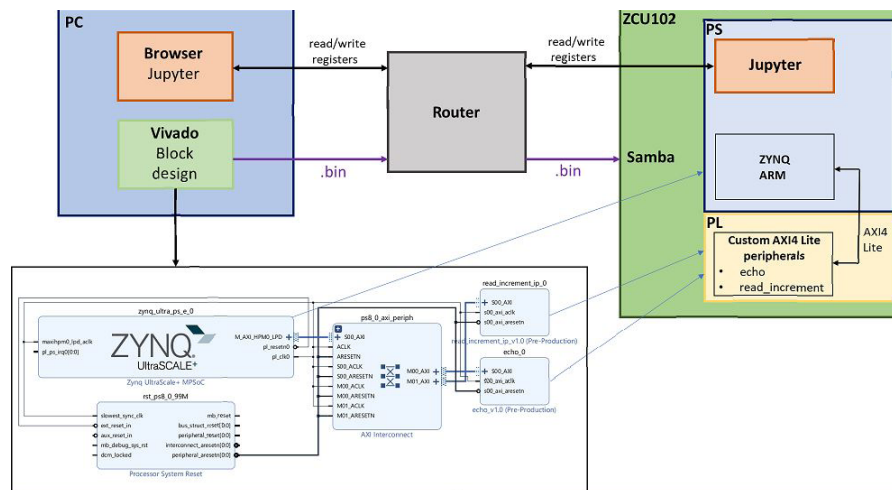

Figure 1. The block diagram for a FPGA implementation of a custom AXI4 Lite peripheral

### Main activities

The main activities in our research project are:

- Study of RISC-V Vector extension;
- Study of the "Ara" coprocessor specialized for RISC-V Vector extension;
- FPGA implementation of the NOEL-V processor;

- Implementation of a custom peripheral for the NOEL-V processor;
- FPGA implementation of the CVA6 CPU;
- FPGA implementation of the PULPino architecture.

```
# initialize 3 arrays to store the values from reg1, reg2 and reg3
read_inc_arr1 = []
read_inc_arr2 = []
read_inc_arr3 = []
readReg1Offset=0x4 #offset for Reg1 ddress
readReg2Offset=0x8 #offset for Reg2 ddress
readReg3Offset=0xC #offset for Reg3 ddress
# read reg1, reg2 and reg3 in a loop and store the read values
for i in range (20):
    reg1=custom_read_increment_ip.read(readReg1Offset)
    read_inc_arr1.append(reg1)
    reg2=custom_read_increment_ip.read(readReg2Offset)
    read_inc_arr2.append(reg2)
    reg3=custom_read_increment_ip.read(readReg3Offset)
    read_inc_arr3.append(reg3)
# plot the values read from the registers
figure, axis = plt.subplots(1, 3)
figure.subplots_adjust(hspace=0.4, wspace=0.6)
axis[0].plot(read_inc_arr1)
axis[0].set_title("Reg1")
axis[1].plot(read_inc_arr2)
axis[1].set_title("Reg2")
axis[2].plot(read_inc_arr3)
axis[2].set_title("Reg3")
plt.show()
```

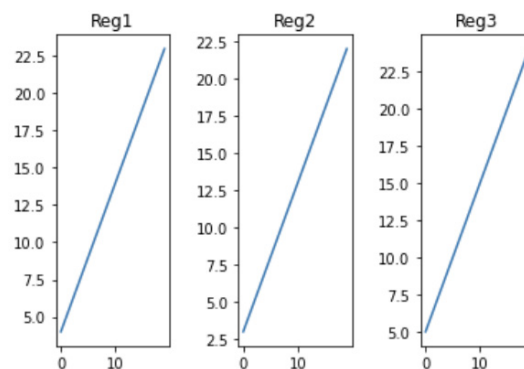

Figure 2. The results obtained in Jupyter for a custom AXI4 Lite peripheral

## Applicability and transferability of the results

- Our research project proposes the use of the reconfigurable logic to develop a control solution for head up displays using innovative RISC-V based architectures, evaluated and validated in FPGA.
- Moreover, the project team will develop, test and validate a demonstrator containing the implemented hardware and software modules that can be used at the main exhibitions in the field.

## Financed through/by

- Continental Automotive Timisoara

## Research Center

Research Center for Intelligent Electronic Systems  
<http://ccsei.upt.ro/>

## Research Team

- Prof. Dr. Eng. Aurel – Ștefan GONTEAN
- Eng. Corneliu BĂRBULESCU
- Eng. Magdalena Patricia MARINCA
- Student Albert BARBU
- Student Vasile BOROICA

## Contact information

Prof. Dr. Eng. Aurel – Ștefan GONTEAN  
Faculty of Electronics, Telecommunications and Information Technologies,  
Department of Applied Electronics  
Address: 2, Vasile Pârvan Blvd., 300223, Timisoara  
Mobile: (+40) 745 121 383  
E-mail: aurel.gontean@upt.ro  
Web: <https://www.etc.upt.ro>

## ENVIRONMENTAL QUALITY CONTROL SERVICE AT TIMISOARA WASTEWATER TREATMENT PLANT

### Goal of the project

The quality of the environment, respectively the water quality of the Bega river, will be monitored in the sector 1 km upstream of the first discharge of the treatment plant and 5 km downstream of the last discharge of the treatment plant into the Bega river.



samples area

### Short description of the project

Interdisciplinary analysis of the physico-chemical and biological parameters and the influence of these parameters on the ichthyofauna, as a result of fish mortality on the Bega River.

### Project implemented by:

**Coordinator:** Politehnica University Timisoara

#### Partners:

- University of Life Sciences "King Mihai I" from Timisoara
- West University of Timisoara

### Implementation period

- 2022-2023

### Main activities

The sector 1 km upstream from the first discharge of the treatment plant and 5 km downstream from the last discharge of the treatment plant in Bega river is analyzed.

The following are analyzed:

1. Water and sediment quality control,
2. Ichthyofauna study (fish habitats, identification of anthropogenic pressures),
3. Malacofauna study (shells and water snails as bioindicators),
4. Study of marsh macrophyte vegetation,
5. Analysis of the physico-chemical and biological parameters, as well as the influence of these parameters on the ichthyofauna,
6. Identify some intervention solutions to protect aquatic flora and fauna.

### Results

The population of microorganisms at the level of the analyzed water samples shows quantitative differences depending on the parameter, respectively the sampling point. Microbiologically (NTG, fecal coliforms, fecal enterococci, fecal streptococci), the highest values are found in the water samples and sediment taken from collection points P3 and P4, which indicates the existence of considerable amounts of waste of organic origin. The best numerically represented are the ammonifying bacteria followed by the nitrifying and denitrifying ones. From a chemical point of view, very high concentrations of ammonia, nitrites and nitrates were recorded, especially in the lower part of the water layer. The ichthyofauna inventory identified specimens that showed congested and hemorrhagic areas on the body / integument / gills, only in medium/large species.

### Applicability and transferability of the results

Nitrogen compounds in different stages of metabolism, as a result of the action of the communities of microorganisms present, can interact with the existing biota at the level of the aquatic ecosystem, causing a negative impact on the survival rate. The obtained results support the finding of intervention solutions to protect aquatic flora and fauna.

## Financed through/by

AQUATIM S.A.

## Research Center

Research Institute for Renewable Energies

<https://www.icer.ro/>

## Research Team

### Project leader:

- Scientific Researcher level II Dr. Chem-Biol. Nicoleta NEMEȘ

### Researchers:

- Prof. Dr. Eng. Petru NEGREA
- Scientific Researcher level II Dr. Chem-Biol. Nicoleta NEMEȘ
- Prof. Dr. Eng. Adina NEGREA
- Scientific Researcher level III Dr. Eng. Maria MIHĂILESCU
- Prof. Dr. Eng. Constantin FLORESCU
- Assoc. Prof. Dr. Ioan BĂNĂȚEAN-DUNEA
- Lecturer Dr. Biol. Milca PETROVICI
- Lecturer Dr. Biol. Nicoleta FILIMON
- Lecturer Dr. Biol. Adrian SINITEAN
- Dr. Biol. Alina CALUȘERIU
- Ph.D. Student Eng. Georgiana MLADIN
- Ph.D. Student Eng. Loredana CIOCĂRLIE

## Contact information

Scientific Researcher level II Dr. Chem-biol. Nicoleta NEMEȘ  
Research Institute for Renewable Energies - UPT,  
138, Gavril Musicescu street, 300501, Timisoara  
Phone: (+40) 256 404 509  
E-mail: [nicoleta.nemes@upt.ro](mailto:nicoleta.nemes@upt.ro)

## INDUSTRIAL RESEARCH SERVICES IN THE PROJECT “INO-SEN-INOVATIVE TECHNOLOGY FOR BUILDING CO<sub>2</sub> DETECTION SENSORS”

### Goal of the project

The goal of the project is to extend the prototyping capabilities of CO<sub>2</sub> detection performant sensors for market penetration, alignment to existent tendencies and elaborating research reports.

### Short description of the project

- The project aims to develop a methodology for innovative product design by considering the voice of the customer.
- A patent can become a breakthrough only if the customer appreciates its value. Thus, the capabilities of a new CO<sub>2</sub> detection sensor have been tested using quality management and neuromarketing tools to propose relevant functionalities for both household and industrial clients.
- The results have been very different for the client segments and strategic development options have been delineated.

### Project implemented by:

Coordinator: Politehnica University Timisoara

### Implementation period

- March 2023 - October 2023

### Main activities

- The main activities of the project are:
  - Identifying and describing the functionalities of a new innovative CO<sub>2</sub> detection sensor which will be researched from the usability and attractivity point of view;
  - Building a Kano questionnaire and analyzing the results;
  - Identifying the design requirements by using the QFD method
  - 3 D prototype design of the final sensor after a screen- based eye tracking research
  - An FMEA for the potential flaws of the designed sensor case

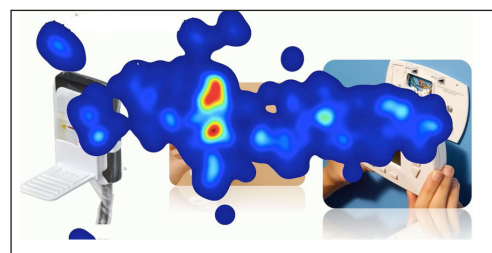
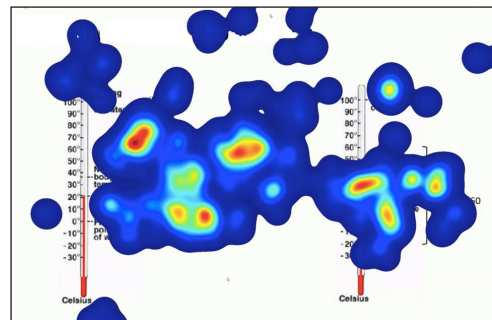
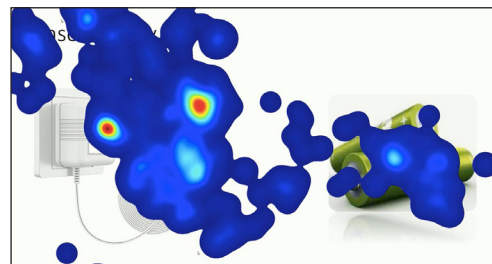

### Results

- The adequate identification of potential client expectations for implementing the most desired functionalities of the product and supplementary characteristics depending on the client segment like communication system reconfiguration, data storage, data visualization, other sensors combined in a more complex product, detection signalization options.
- 3D design of the new sensor case respecting the eye tracking results and the FMEA analysis

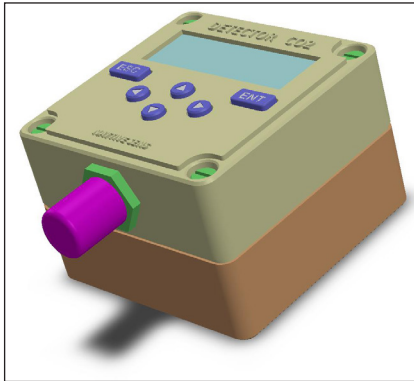

### Applicability and transferability of the results

- A final 3D design for the innovative sensor has been proposed together with the hierarchy of HoQ design requirements and FMEA defect evaluation.

- Future preoccupation could be represented by using the eye tracking technique on the final product and different international and national potential clients.

- Lessons learned have been delineated, research papers have been prepared for publication and the proposed methodology can be used in various situations on different company products and services.

### Financed through/by

Native - Senz SRL

### Research Center

Research Center for Engineering and Management

<http://www.mpt.upt.ro/eng/research/research-center.html>

### Research Team

#### Project leader:

- Lecturer Dr. Eng. Sabina POTRA

#### Researchers:

- Assoc. Prof. Dr. Eng. Luisa DUNGAN

- Assist. Prof. Dr. Lavinia CERNESCU

### Contact information

Lecturer Dr. Eng. Sabina POTRA

Faculty of Management in Production and Transportation

Department of Management

Address: 14, Remus Street, 300191, Timisoara

Phone: (+40) 256-404284

E-mail: [sabina.potra@upt.ro](mailto:sabina.potra@upt.ro)

## EXPERIMENTAL DEVELOPMENT SERVICES WITHIN THE PROJECT “INO-SEN - INNOVATIVE TECHNOLOGY FOR THE REALIZATION OF SENSORS FOR GREENHOUSE GASES”

### Goal of the project

Indoor carbon dioxide (CO<sub>2</sub>) has played a key role in the development of home and workplace ventilation systems and indoor air quality (IAQ) assessment for decades. Moreover, in the past pandemic context numerous studies showed the relation between CO<sub>2</sub> concentrations and virus exposure in work spaces. In the frame of a bigger project our team studied the behaviour of a novel CO<sub>2</sub> detection sensors, developed by the spin-off company Nattive – Senz SRL from Timisoara, in various working environments, novelty of the sensor given by Surface Acoustic Wave (SAW) technology.

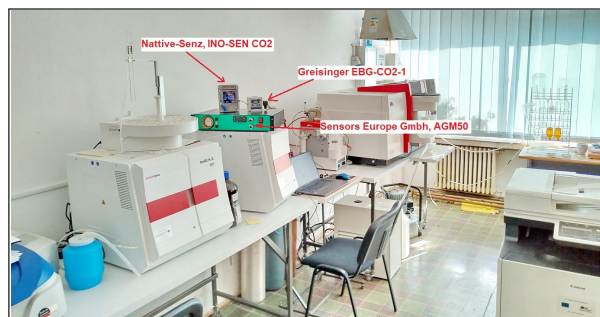

### Short description of the project

A CO<sub>2</sub> detection SAW sensor performances were evaluated in 3 intercomparison exercises with 2 NDIR reference CO<sub>2</sub> analyzers.

### Project implemented by

Coordinator: Politehnica University Timisoara,  
Faculty of Mechanical Engineering  
Department of Mechanical Machines, Equipment and Transportation

### Implementation period

25.03-31.12.2023

### Main activities

Project was setup in two main activities:

- **A first stage**, experimental setup development

In this step 3 analytical equipment's were tandem regulated to provide simultaneous data in the same time, for the same air sample analyzed. One reference instrument was used (Sensors Europe GmbH - AGM50) and one industrial sensor (Greisinger EBG-CO2-1R), both NDIR ((Non-Dispersive Infra-Red) CO<sub>2</sub> analyzers.

The third in setup was our experimental Nattive-Senz INO-SEN CO<sub>2</sub>, a **SAW (Surface Acoustic Wave) sensor** with unknown performance characteristics.

They were used to tandem measure the CO<sub>2</sub> concentration in indoor air in a laboratory, a classroom and an office space.

- **The second stage** was dedicated to recorded data analysis through proficiency testing defined in ISO 17043:2010 and ISO 13528:2023. Statistical analysis by Cochran test, Fisher test, Anova test, SAP test, Grubb test and En and Z scores were performed to obtain final results.

### Results

During the project activities the main results expected were reached:  
- 3 intercomparison exercises were conducted, over a period of 4 -5 days each, in the premises of Faculty of Mechanical Engineering, in Laboratory N113, Office M302 and Multifunctional Laboratory



- Data analysis was performed on the basis of EN ISO 17043:2010 and EN ISO 13528:2023 reference proficiency testing standards followed by statistical evaluation of obtained measurement results.

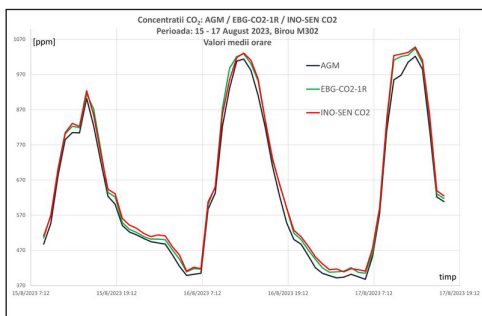

- Statistical calculation of Cochran test, Fisher test, Anova test and En and Z scores was done. Results were presented to the beneficiary in the form of an extensive Research report.

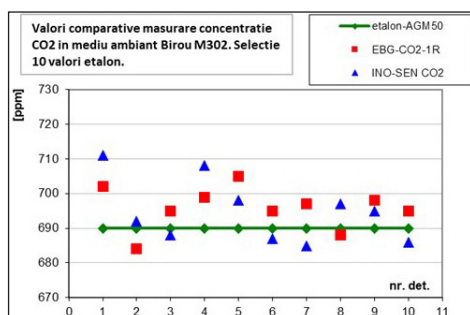

- The conclusion that the INO-SEN CO<sub>2</sub> SAW sensor is adequate for indoor CO<sub>2</sub> measurements applications and should be developed for commercial use.

## Applicability and transferability of the results

- At national level, in Romania, the field of sensors integrated into sensitive platforms is currently a pole of interest for research institutes and even for some economic agents, due in part to the fact that Romania will have to intensify its efforts to align with European standards, very strict in terms of controlling toxic gases in the atmosphere and remedying the effects of pollution with them.
- Thus, CO<sub>2</sub> detection sensors are essential in the current context both as a strategy to prevent CO<sub>2</sub> emissions and to avoid illness of employees working in closed environments.
- During the sustainability period of the project, the development of other sensors for household use is pursued, based on the same principle.

## Financed through/by

- Economic operator (contracts concluded with third parties):  
S.C. Nattive – Senz SRL

## Research Center

- Research Center for Renewable Energy

## Research Team

### Project leader:

- Assoc. Prof. Dr. Eng. Ec. Luisa Izabel DUNGAN

### Researchers:

- Assoc. Prof. Dr. Eng. Francisc POPESCU

- Lecturer Dr. Eng. Ramon Mihai BALOGH

- Asist. Prof. Dr. Ec. Lavinia Maria CERNESCU

## Contact information

Assoc. Prof. Dr. Eng. Ec. Luisa Izabel DUNGAN

Faculty of Mechanical Engineering

Department of Mechanical Machines, Equipment and Transportation

Address: 1, Mihai Viteazu Blvd., 300222, Timisoara

Phone: (+40) 256 403723

Mobile: (+40) 724230340

E-mail: luisa.dungan@upt.ro



## SMART CITY CONSULTANCY FOR THE IMPLEMENTATION OF THE GRCF2 W2: 2022.005424/15763/112065 - GRCF2 W2 - TIMISOARA CITY TRAMS: GREEN CITY ACTION PLAN

### Goal of the project

- Develop the **Action Plan for Timisoara Green City**, with the support of the EBRD.
- Identify and implement actions and investments to address priority environmental issues in the city.

### Short description of the project

Assessment of the Smart Maturity of the city of Timisoara and other actions for developing the **Action Plan for Timisoara Green City**.

### Project implemented by

Research Center for Multimedia, Politehnica University Timisoara  
Green Partners SRL, Cluj-Napoca

### Implementation period

15.12.2022 – 31.10.2023

### Main activities

Main activities of the Research Center in Multimedia:

- Provide specific input to legal framework assessment on Urban Planning – especially on Smart Maturity Assessment.
- Input on relevant sectors indicators / identifying additional indicators to be considered, in case of data gaps, irrelevance of indicators in methodology – Smart Maturity assessment.
- Review draft report, provide technical feedback on areas of expertise, ask further questions if needed for understanding the City's needs and developing of proposed actions.

### Results

**Smart Maturity Assessment for Timisoara Green City Action Plan consisting of 48 pages with the following structure:**

- Foundational Components
  - Policies, strategies, and programs
  - Institutional Ecosystem
  - Technical components

#### 2. Sectoral Assessment

- Transport and Infrastructure
- Energy and Buildings
- Industry
- Waste
- Water
- Land-Use

#### 3. Data Integration & Cross-Sectoral Approaches

#### 4. Smart Maturity Assessment

## Applicability and transferability of the results

- Timisoara is in its Enabling stage of smart initiatives and digital transformation. This means that the Municipality acknowledges the importance of smart components, has already developed / implemented certain smart solutions and is making efforts to digitalize as many processes as possible.

Still, there is room for improvements in all sectors and at the Municipality level.

The main challenges that the city is facing concerning the digitalization process refer to:

- Limited institutional capacities for Smart Integration and Digital Transformation.
- Low-level and difficult online interaction of the citizens with the Municipality.
- Limited capacity for capturing, processing and exposing data for traffic modelling, route planning, land management.
- Limited data capturing and sharing in a cross-sectorial approach.
- Limited engagement and involvement of private / industry ecosystem in smart initiatives.

## Financed through/by

EBRD Green Climate Fund

## Research Center

Research Center for Multimedia

## Research Team

- Assoc. Prof. Dr. Eng. Silviu VERT

## Contact information

Assoc. Prof. Dr. Eng. Silviu VERT

Faculty of Electronics, Telecommunications and Information Technologies, Department of Communications

Address: 2 Vasile Parvan Boulevard, 300223, Timisoara

Phone: (+40) 256 403 300

E-mail: silviu.vert@upt.ro

Project Website:

<https://www.cm.upt.ro/proiecte-nationale/smart-city-gcap-timisoara/>

## RESEARCHING COMPUTER VISION ALGORITHMS FOR DETECTING THE GROUND PROFILE IN 3D

### Goal of the project

The goal of the project is to increase the collaboration between the company and university scholars by doing research in automotive Autonomous Driving (AD) domain. The main task of the project is to implement a solution regarding the removal of flat world assumptions in AD.

### Short description of the project

Accurate localization of other traffic participants is a vital task in autonomous driving systems. State-of-the-art systems employ a combination of sensing modalities such as RGB cameras and LiDARs for localizing traffic participants, but most such demonstrations have been confined to plain roads. With the advent and subsequent commercialization of autonomous driving, there is an increased interest in monocular object localization for urban driving scenarios.

The goals of the project:

- Investigating current state of the art solutions for ground plane profile detections
- Researching and developing own solution for ground plane profile detection based on single image from a fish-eye camera model situated on the vehicle. Solution that runs on a PC environment
- Implementing the solution on Continental products and specific SoC taking into account the limitations in processing power and processing time
- Researching and developing a testing framework which is able to verify and validate the given solution

### Project implemented by:

**Coordinator:** Politehnica University Timisoara

### Implementation period

- 01.04.2022 - 31.03.2023

### Main activities

- Research in the field of ground plane profile detection (GPD)
- Image acquisition using Continental equipment
- Image labelling
- Finding the most appropriate models for GPD
- Algorithm development and implementation for GPD
- Testing and validation of the algorithm that runs on a PC environment

- Implementing the solution on Continental products and specific SoC taking in account the limitations in processing power and processing time
- Researching and developing a testing framework which is able to verify and validate the given solution
- Project management
- Dissemination of results

### Results

The results of the project consist in:

- A study regarding the state of the art solutions for ground plane profile
- Identification of publicly available datasets
- Algorithm implementation, testing and validation

### Applicability and transferability of the results

- In order to estimate the ground profile, there were identified two main approaches: one that focuses on geometrical features using classical computer vision paradigms, and the other one employing deep neural networks
- During the research we try to circumvent the lack of manually labeled automotive datasets by using reliable automatic feature detectors
- Future preoccupation could be represented by optimizing the neural models for deployment to EdgeAI devices

**Financed through/by**

CONTINENTAL AUTOMOTIVE ROMANIA S.R.L

**Research Center**

Research Center for Intelligent Electronic Systems

**Research Team****Project leader:**

- Assoc. Prof. Dr. Eng Georgiana SIMION

**Researchers:**

- Prof. Dr. Eng. Cătălin Daniel CĂLEANU

- Assoc. Prof. Dr. Eng. Popa CĂLIN

- Assoc. Prof. Dr. Eng. Ioan JIVEȚ

- Lecturer Dr. Eng. Ciprian DAVID

- Ms.C. Student Eng. Ionatan Robert ȘOFRAC

**Contact information**

Assoc. Prof. Dr. Eng. Georgiana SIMION

Faculty of Electronics, Telecommunications and Information  
Technologies

Department of Applied Electronics

2, Vasile Pârvan Blvd., 300223, Timisoara

Phone: (+40) 256 403 291

E-mail: georgiana.simion@upt.ro

## HARDWARE VERIFICATION MANUAL UPDATE AND IMPLEMENTATION

### Goal of the project

- Updating the existing hardware verification manuals of components and electronic control units and creating manuals for the newly introduced circuits used by Vitesco Technologies Engineering company.

### Short description of the project

- Update or generate, as appropriate, hardware verification manuals for specific ASICs used in Automotive (Powertrain).

### Project implemented by:

#### Coordinator:

Politehnica University Timisoara

### Implementation period

02.08.2023-02.08.2024

### Main activities

- Update existing hardware verification manuals in accordance with the requirements of the integration plans
  - Studying the documents related to the tests / measurements to be performed
  - Generation of manuals for newly introduced components to be integrated into the electronic control unit (ECU)
  - Participate in online meetings on testing requirements
- The updating of the manuals refers both to the steps to be executed and to the experimental setup (how the devices must be interconnected)
- Review of the verification reports generated by colleagues in tests/ measurements performed manually or through semi-automatic tests
  - Verifying that the manuals are correctly understood
  - Changes to the hardware verification manuals for a better understanding of the test mode

### Results

- Hardware verification manual updates for:
  - DC-DC circuits
  - Power supply and voltage monitoring unit
  - High/Low side driver
  - H-Bridge driver
- Start of a new manual referring on a e-fuse circuit.

### **Applicability and transferability of the results**

- In the generation of a new hardware verification manual or updating an existing one, it is useful to collaborate with colleagues who carry out the necessary measurements in tests / hardware verifications to establish in detail how they should be carried out.
- The documents are used within Vitesco, at all branches where ECU checks are performed.

### **Financed through/by**

- Vitesco Technologies Engineering Romania SRL

### **Research Team**

#### **Project leader:**

- Lecturer Dr. Eng. Robert PAZSITKA

#### **Researcher:**

- Lecturer Dr. Eng. Robert PAZSITKA

### **Contact information**

Lecturer Dr. Eng. Robert PAZSITKA

Faculty of Electronics, Telecommunications and Information Technologies

Department of Measurements and Optical Electronics

Address: No. 2, Vasile Pärvan Blvd., 300223, Timisoara

Phone: (+40) 256 403 365

E-mail: robert.pazsitka@upt.ro

## COTOFENII DIN DOS (158.2 MW) AND COSOVENI (128.4 MW) PHOTOVOLTAIC POWER PLANTS' INTEGRATION IN THE ROMANIAN POWER SYSTEM

### Goal of the project

- Currently, there is a very increased interest for unconventional power producers' integration in the Romanian National Power System. The project deals with power system analysis and optimization for the photovoltaic (PV) power sources' integration in the Romanian Power System (Oltenia area Distribution System Operator). The Southern part of Romania (named Oltenia area) has been used as case study. The corresponding distribution network is managed by the DEO Distribution System Operator.

The goal of the project is to perform the power system operating conditions analysis in order to integrate within the Romanian Power System the following PV power producers: Cotofenii din Dos (158.2 MW rated power) and Cosoveni (128.4 MW rated power).

### Short description of the project

- The unconventional power producers represent an important issue for the Romanian and EU energy policy and sustainable development strategy. The project refers to photovoltaic power sources integration in the Southern area of the Romanian Power System. Various scenarios considering the consumption forecast for 2026 and 2031 years have been considered, taking into account all the renewable energy sources (wind, photovoltaic, biomass, hydro). The analyses have been performed for the transmission and distribution networks from the interest area, in order to highlight the influence of the new power producers on the distribution network.

### Project implemented by:

#### Coordinator:

Politehnica University Timisoara

#### Partner:

- S.C. EuroTulip S.R.L., Targu Jiu

### Implementation period

17.04.2023 – 17.06.2023

### Main activities

- Modeling all the unconventional power producers that have to be taken into consideration for the involved power system area;
- Power system operating conditions analysis considering various scenarios;
- Oltenia area distribution network modelling and power system operating conditions analysis;
- Steady-state power system analyses;

- Contingencies analyses for the power systems area where the new PV power producers are going to be integrated;
- Voltage regulation and reactive power variation analysis;
- Transient stability analysis;
- Analysis of the electrical network reinforcement works' necessity.

### Results

- Power flow computing corresponding to the 2026 and 2031 years forecasting scenarios (transmission and distribution network levels), considering the absence / presence of the new PV power producers;
- Voltage value variation considering the absence / presence of the new PV power producers;
- Power flow through the power system elements and loading level;
- Analysis of the new power producers' influence on the technical losses;
- Contingencies analyses considering the presence / absence of the new PV power producers;
- Network integration solution validation and electrical network reinforcement recommendations (if necessary).

### **Applicability and transferability of the results**

- Applicability for unconventional power producers' integration in actual, complex, power systems.

Knowledge transfer to other photovoltaic power plants developers, respectively to the electrical distribution network operators (DEO, Retele Electrice Banat, DelGaz Grid, DEER) and to the transmission system operator.

### **Financed through/by**

- Private sources (S.C. EuroTulip S.R.L., Targu Jiu)

### **Research Center**

- Research Center for Power Systems Analysis and Optimization

### **Research Team**

#### **Project leader:**

- Prof. Dr. Eng. Stefan KILYENI

#### **Researchers:**

- Assoc. Prof. Dr. Eng. Constantin BARBULESCU

- PhD Student Eng. Alex BITTENBINDER

- PhD Student Eng. Marin SALINSCHI

- PhD Student Eng. Andrei STELESCU

- PhD Student Eng. Radoslav RAICOV

### **Contact information**

Prof. Dr. Eng. Stefan KILYENI

Faculty of Electrical and Power Engineering / Department of Electric Power Systems Engineering

Address: No. 2, Bd. Vasile Parvan, 300223, Timisoara

Phone: (+40) 256 403 416

Mobile: 0745.180.818

E-mail: stefan.kilyeni@upt.ro



## THEORETICAL AND APPLIED RESEARCH REGARDING THE PHOTOVOLTAIC AND WIND POWER PLANTS' INTEGRATION IN COMPLEX POWER SYSTEMS. CASE STUDIES FOR THE ROMANIAN POWER SYSTEMS, PHOTOVOLTAIC POWER PLANTS HORIA 1 (40 MW), HORIA 2 (273 MW), TOMNATIC (33 MW), MOSNITA (49 MW), RESITA (24 MW), ORTISOARA (47 MW) FROM E-DISTRIBUTIE BANAT DISTRIBUTION SYSTEM OPERATOR

### Goal of the project

- Currently, there is a very increased interest for unconventional power producers' integration in the Romanian National Power System. The project deals with power system analysis and optimization for the photovoltaic (PV) power sources' integration in the Romanian Power System (Banat area Distribution System Operator). The Western part of Romania (named Banat area) has been used as case study. The corresponding distribution network is managed by the e-Distributie Banat Distribution System Operator.

The goal of the project is to perform the power system operating conditions analysis in order to integrate within the Romanian Power System the following PV power producers: Horia 1 (rated power 40 MW), Horia 2 (rated power 273 MW), Tomnatic (rated power 33 MW), Mosnita (rated power 49 MW), Resita (rated power 24 MW) and Ortisoara (rated power 47 MW).

### Short description of the project

The unconventional power producers represent an important issue for the Romanian and EU energy policy and sustainable development strategy. The project refers to photovoltaic power sources integration in the Western area of the Romanian Power System. Various scenarios considering the consumption forecast for 2026 and 2031 years have been considered, taking into account all the renewable energy sources (wind, photovoltaic, biomass, hydro). The analyses have been performed for the transmission and distribution networks from the interest area, in order to highlight the influence of the new power producers on the distribution network.

### Project implemented by:

#### Coordinator:

Politehnica University Timisoara

#### Partners:

- S.C. Electroechipament Industrial S.R.L., Resita

### Implementation period

09.10.2023 – 09.12.2023

### Main activities

- Modeling all the unconventional power producers that have to be taken into consideration for the involved power system area;
- Power system operating conditions analysis considering various scenarios;
- Banat area distribution network modelling and power system operating conditions analysis;
- Steady-state power system analyses;
- Contingencies analyses for the power systems area where the new PV power producers are going to be integrated;
- Voltage regulation and reactive power variation analysis;
- Transient stability analysis;
- Analysis of the electrical network reinforcement works' necessity.

### Results

- Methodology elaborated for unconventional power producers' integration;
- Artificial intelligence based power flow computing algorithms development;
- Power flow computing corresponding to the 2026 and 2031 years forecasting scenarios (transmission and distribution network levels), considering the absence / presence of the new PV power producers;
- Voltage value variation considering the absence / presence of the new PV power producers;
- Power flow through the power system elements and loading level;
- Analysis of the new power producers' influence on the technical losses;
- Contingencies analyses considering the presence / absence of the new PV power producers;
- Network integration solution validation and electrical network reinforcement recommendations (if necessary).

### Applicability and transferability of the results

- Applicability for unconventional power producers' integration in actual, complex, power systems.

Knowledge transfer to other photovoltaic power plants developers, respectively to the electrical distribution network operators (e-Distributie Banat, DEO, DelGaz Grid, DEER) and to the transmission system operator.

### **Financed through/by**

- Private sources  
(S.C. Electrochipament Industrial S.R.L., Resita)

### **Research Center**

- Research Center for Power Systems Analysis and Optimization

### **Research Team**

#### **Project leader:**

- Prof. Dr. Eng. Stefan KILYENI

#### **Researchers:**

- Assoc. Prof. Dr. Eng. Constantin BARBULESCU
- PhD Student Eng. Alex BITTENBINDER
- PhD Student Eng. Marin SALINSCHI
- Assoc. Prof. Dr. Annamaria KILYENI
- PhD Student Eng. Flavius TODERICA
- PhD Student Eng. Andrei STELESCU
- PhD Student Eng. Alexandru STOIAN
- PhD Student Eng. Marilena ZAMFOR
- PhD Student Eng. Radoslav RAICOV

### **Contact information**

Prof. Dr. Eng. Stefan KILYENI  
Faculty of Electrical and Power Engineering / Department of Electric  
Power Systems Engineering  
Address: No. 2, Bd. Vasile Parvan, 300223, Timisoara  
Phone: (+40) 256 403 416  
Mobile: 0745.180.818  
E-mail: stefan.kilyeni@upt.ro

THEORETICAL AND APPLIED RESEARCH REGARDING THE PHOTOVOLTAIC AND WIND POWER PLANTS' INTEGRATION IN COMPLEX POWER SYSTEMS. CASE STUDIES FOR THE ROMANIAN POWER SYSTEMS, PHOTOVOLTAIC POWER PLANTS IACOBENI (4.95 MW), PRUNDU BARGAULUI (6 MW), STALPU 1 (5 MW), STALPU 2 (9 MW) FROM DEER DISTRIBUTION SYSTEM OPERATOR

## Goal of the project

- Currently, there is a very increased interest for unconventional power producers' integration in the Romanian National Power System. The project deals with power system analysis and optimization for the photovoltaic (PV) power sources' integration in the Romanian Power System (North and South Transilvania, respectively North Muntenia areas Distribution System Operator). North and South Transilvania, respectively North Muntenia areas have been used as case studies. The corresponding distribution network is managed by the DEER Distribution System Operator.

The goal of the project is to perform the power system operating conditions analysis in order to integrate within the Romanian Power System the following PV power producers: Iacobeni (rated power 4.95 MW), Prundu Bargaului (rated power 6 MW), Stalpu 1 (rated power 5 MW) and Stalpu 2 (rated power 9 MW).

## Short description of the project

- The unconventional power producers represent an important issue for the Romanian and EU energy policy and sustainable development strategy. The project refers to photovoltaic power sources integration in the North and South Transilvania, respectively North Muntenia areas of the Romanian Power System. Various scenarios considering the consumption forecast for 2026 and 2031 years have been considered, taking into account all the renewable energy sources (wind, photovoltaic, biomass, hydro). The analyses have been performed for the transmission and distribution networks from the interest areas, in order to highlight the influence of the new power producers on the distribution network.

### Project implemented by:

#### Coordinator:

Politehnica University Timisoara

#### Partners:

- S.C. Romproiect Electro S.R.L., Cluj-Napoca

### Implementation period

09.10.2023 – 09.12.2023

### Main activities

- Modeling all the unconventional power producers that have to be taken into consideration for the involved power system areas;
- Power system operating conditions analysis considering various scenarios;
- Banat area distribution network modelling and power system operating conditions analysis;

- Steady-state power system analyses;
- Contingencies analyses for the power systems' areas where the new PV power producers are going to be integrated;
- Voltage regulation and reactive power variation analysis;
- Transient stability analysis;
- Analysis of the electrical network reinforcement works' necessity.

### Results

- Methodology elaborated for unconventional power producers' integration;
- Artificial intelligence based power flow computing algorithms development;
- Power flow computing corresponding to the 2026 and 2031 years forecasting scenarios (transmission and distribution network levels), considering the absence / presence of the new PV power producers;
- Voltage value variation considering the absence / presence of the new PV power producers;
- Power flow through the power system elements and loading level;
- Analysis of the new power producers' influence on the technical losses;
- Contingencies analyses considering the presence / absence of the new PV power producers;
- Network integration solution validation and electrical network reinforcement recommendations (if necessary).

### **Applicability and transferability of the results**

- Applicability for unconventional power producers' integration in actual, complex, power systems.
- Knowledge transfer to other photovoltaic power plants developers, respectively to the electrical distribution network operators (DEER, e-Distributie Banat, DEO, DelGaz Grid) and to the transmission system operator.

### **Financed through/by**

- Private sources (S.C. Romproiect Electro S.R.L., Cluj-Napoca)

### **Research Center**

Research Centre for Power Systems Analysis and Optimization

### **Research Team**

#### **Project leader:**

- Prof. Dr. Eng. Stefan KILYENI

#### **Researcher:**

- Assoc. Prof. Dr. Eng. Constantin BARBULESCU
- PhD Student Eng. Alex BITTENBINDER
- PhD Student Eng. Marin SALINSCHI
- Assoc. Prof. Dr. Annamaria KILYENI
- PhD Student Eng. Andrei STELESCU
- PhD Student Eng. Flavius TODERICA
- PhD Student Eng. Hamza BOUBIA

### **Contact information**

Prof. Dr. Eng. Stefan KILYENI  
Faculty of Electrical and Power Engineering / Department of Electric  
Power Systems Engineering  
Address: No. 2, Bd. Vasile Parvan, 300223, Timisoara  
Phone: (+40) 256 403 416  
Mobile: 0745.180.818  
E-mail: stefan.kilyeni@upt.ro

THEORETICAL AND APPLIED RESEARCH REGARDING THE PHOTOVOLTAIC AND WIND POWER PLANTS' INTEGRATION IN COMPLEX POWER SYSTEMS. CASE STUDIES FOR THE ROMANIAN POWER SYSTEMS, PHOTOVOLTAIC POWER PLANTS BUCOVAT (3 MW), BEREGSAU MARE (2.5 MW), DETA (1 MW), ORTISOARA (2.5 MW) AND TUSTEA (2.54 MW) FROM E-DISTRIBUTIE BANAT DISTRIBUTION SYSTEM OPERATOR

## Goal of the project

- Currently, there is a very increased interest for unconventional power producers' integration in the Romanian National Power System. The project deals with power system analysis and optimization for the photovoltaic (PV) power sources' integration in the Romanian Power System (Banat area Distribution System Operator). The Western part of Romania (named Banat area) has been used as case study. The corresponding distribution network is managed by the e-Distributie Banat Distribution System Operator.

The goal of the project is to perform the power system operating conditions analysis in order to integrate within the Romanian Power System the following PV power producers: Bucovat (rated power 3 MW), Beregsau Mare (rated power 2.5 MW), Deta (rated power 1 MW), Orisoara (rated power 2.5 MW) and Tustea (rated power 2.54 MW).

## Short description of the project

- The unconventional power producers represent an important issue for the Romanian and EU energy policy and sustainable development strategy. The project refers to photovoltaic power sources integration in the Western part of the Romanian Power System. Various scenarios considering the consumption forecast for 2026 and 2031 years have been considered, taking into account all the renewable energy sources (wind, photovoltaic, biomass, hydro). The analyses have been performed for the transmission and distribution networks from the interest area, in order to highlight the influence of the new power producers on the distribution network.

## Project implemented by:

### Coordinator:

Politehnica University Timisoara

### Partners:

- S.C. M.D. Electric S.R.L., Sag

## Implementation period

09.10.2023 – 09.12.2023

## Main activities

- Modeling all the unconventional power producers that have to be taken into consideration for the involved power system area;
- Power system operating conditions analysis considering various scenarios;
- Banat area distribution network modelling and power system operating conditions analysis;
- Steady-state power system analyses;

- Contingencies analyses for the power systems' areas where the new PV power producers are going to be integrated;
- Voltage regulation and reactive power variation analysis;
- Transient stability analysis;
- Analysis of the electrical network reinforcement works' necessity.

## Results

- Methodology elaborated for unconventional power producers' integration;
- Artificial intelligence based power flow computing algorithms development;
- Power flow computing corresponding to the 2026 and 2031 years forecasting scenarios (transmission and distribution network levels), considering the absence / presence of the new PV power producers;
- Voltage value variation considering the absence / presence of the new PV power producers;
- Power flow through the power system elements and loading level;
- Analysis of the new power producers' influence on the technical losses;
- Contingencies analyses considering the presence / absence of the new PV power producers;
- Network integration solution validation and electrical network reinforcement recommendations (if necessary).

### **Applicability and transferability of the results**

- Applicability for unconventional power producers' integration in actual, complex, power systems.

Knowledge transfer to other photovoltaic power plants developers, respectively to the electrical distribution network operators (e-Distributie Banat, DEO, DEER, DelGaz Grid) and to the transmission system operator.

### **Financed through/by**

- Private sources (S.C. M.D. Electric S.R.L., Sag)

### **Research Center**

Research Centre for Power Systems Analysis and Optimization

### **Research Team**

#### **Project leader:**

- Prof. Dr. Eng. Stefan KILYENI

#### **Researcher:**

- Assoc. Prof. Dr. Eng. Constantin BARBULESCU

- PhD Student Eng. Alex BITTENBINDER

- PhD Student Eng. Marin SALINSCHI

- Assoc. Prof. Dr. Annamaria KILYENI

- PhD Student Eng. Alexandru STOIAN

- PhD Student Eng. Marilena ZAMFOR

- PhD Student Eng. Hamza BOUBIA

### **Contact information**

Prof. Dr. Eng. Stefan KILYENI

Faculty of Electrical and Power Engineering

Department of Electric Power Systems Engineering

Address: No. 2, Bd. Vasile Parvan, 300223, Timisoara

Phone: (+40) 256 403 416

Mobile: 0745.180.818

E-mail: stefan.kilyeni@upt.ro

# GRANTED PATENTS





INVENTORS: L. PÎSLARU - DĂNESCU, M. POPA, C.I. ILIE, R.A.CHIHAIA, C.A.BABUTANU, S.NICOLAIE, F.BUNEA, F.D.STOIAN, S.HOLOTESCU, O.M. MARINICA, M. MOREGA, J.B.DUMITRU, N.C.POPA

PATENT NO. RO 131757 B1/ 2023

## PLANAR TRANSFORMER WITH MAGNETIC NANOFUID



- The invention relates to a **low-voltage low-power planar transformer, with magnetic nanofluid**, used in electronic circuits as a fly-back transformer (Fig.1).

- According to the invention, this transformer consists of an assembly of planar coils made of primary and, respectively, secondary planar coils (1a and 1b), fixed using two spacers (3a and 3b), a magnetic circuit assembly, a casing consisting of the tank (6) and the cover (7), a sealing gasket (8) and a central screw (9), aimed at fastening the assembly of planar coils with the tank (6), while the cover (7) includes a terminal box (10), and a system (11) to supply the magnetic nanofluid.

- The two primary planar coils (1a) and the two secondary planar coils (1b) are identical, each disposed on a glass-textolite plate that is plated on each side with a copper layer, every planar coil (1a and 1b) being made of two semi-coils of 20 turns each, in serial connection, disposed on each side of the plate, such that each of the primary and secondary coils has 40 turns, the secondary coils (1b) being disposed between the primary coils (1a).

- The coils are insulated using the three insulations (2). The magnetic circuit assembly consists of two magnetic cores (4a and 4b) made of ferrite, symmetrically overlapped, and of a liquid core of magnetic nanofluid (5), in which the coil assembly and the magnetic cores (4a and 4b) are immersed.

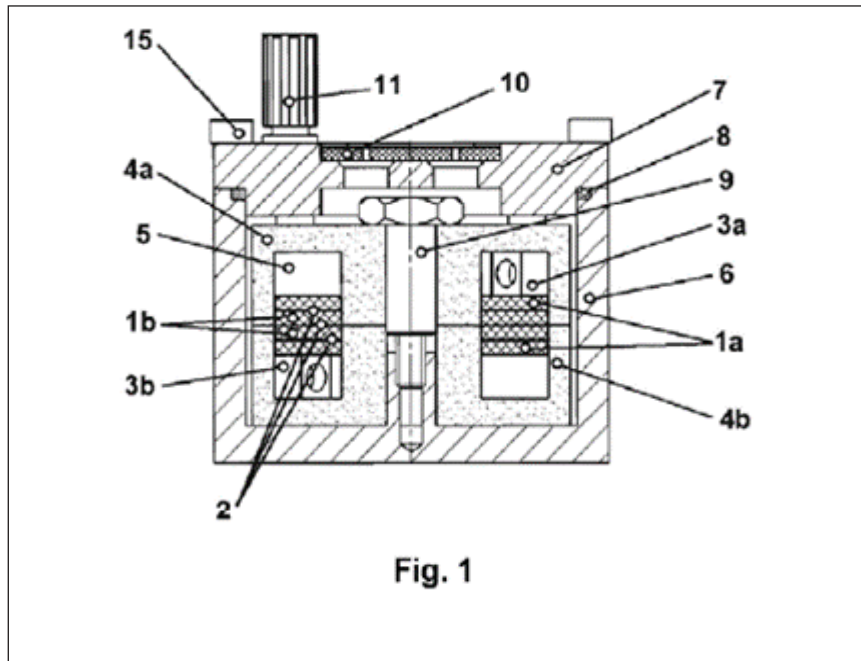

• The advantages of the invention are as follows:

- Miniaturization through the planar constructive form of the coils, as well as their positioning in the coils assembly, which contributes to the improvement to the magnetic coupling with up to 10%;
- Use of a specific magnetic nanofluid, with high saturation magnetization, between 500 G and 1000 G, as a liquid core, part of the magnetic circuit, which eliminates all the gaps and the dispersion magnetic field lines and results in an improved magnetic coupling with up to 10% and the increase of the global efficiency with up to 5%;
- Use of the ferrite cores superposed symmetrically with the specific magnetic nanofluid layers to make the magnetic circuit assembly that allows for the extension of the frequency domain up to 1000 MHz
- The characteristics of this transformer make it suitable for use in DC/DC converters in the field of energy harvesting.

INVENTOR: TUDOR ALEXANDRU ICLANZAN

PATENT NO. RO 131863 B1/ 2023

## UNDERGROUND WASTE STORAGE INSTALLATION



- The invention refers to an underground facility for storing household or recyclable waste in public spaces.

- In general, waste is collected in open, semi-open or closed containers. Their placement in the vicinity of homes or in public spaces causes considerable pollution that is more accentuated in hot and/or rainy months, an unpleasant image of the location and often access to waste handling by people with uncivilized behavior.

- In order to eliminate these shortcomings, in recent years the system of underground waste storage has been increasingly adopted.

- The technical problem of the invention is to create an underground waste storage facility, of simple construction, which uses the constructive elements of the concrete enclosure and the related metal structure to guide the vertical movements of a simple platform that supports the containers and to guide the movements the closing plate of the enclosure, using removable and portable electromechanical or hydraulic actuation means and allowing the notification of the overflow state of the containers.

- The underground facility for storing waste according to the invention is made up of a parallelepiped basin-type concrete enclosure arranged in the ground with the open part of the basin at ground level, inside which a support platform for some waste containers, which can be fed from the upper part through some towers arranged on an upper plate with the role of a cover for the concrete enclosure. It is slightly elevated from the ground level to avoid its flooding.

- Inside the concrete enclosure, on its parallelepiped configuration, a structure, also of parallelepiped type, consisting of tubular metal profiles, which ensures the rolling paths and guides the vertical movement of the support platform that supports the containers and the movement on horizontal, for closing or opening the concrete enclosure of the upper plate that also supports the container feeding towers.
- The actuation of the support platform is carried out with some actuation and transmission mechanisms of the screw-nut type or some linear hydromotors. Moving the upper plate to open access to the containers is done by moving it horizontally, on the horizontal rails of the metal structure. After opening the access to the containers, the lifting and lowering mechanisms of the support platform are activated and the support platform moves vertically to extract, empty and reset the waste containers.
- The moving of the mobile platform and the upper plate is done using the internal vertical and horizontal internal sections of the metal structure profiles as running and guiding paths. On these, movement is done using pairs of rolling rollers placed crosswise at the ends of the support plate and the upper plate.
- At the base of the turrets arranged on the upper plate there is a shutter plate which closes the access to the underground enclosure in the normal position and opens when waste is introduced, being operated by a turret cover by means of a cable which includes on a limited portion a piston cylinder provided with a spring and which, in the extension position of the cable, determined by the weight of the flap, keeps the electrical contact of a signaling circuit interrupted and open.
- When the shutter plate no longer closes, due to the filling of the waste containers, the flexing of the cable occurs and thus closes the electrical contact in the piston cylinder, which will be actuated by its spring and thus signals or transmits a message of pre- full.
- The installation for storing waste, according to the invention, presents the following advantages:
  - It presents a simple construction, in which the metal structure is minimal and provides running and guiding paths for the mobile platform of the containers and for the closing plate of the enclosure;
  - Allows handling for emptying and repositioning only of the container with its support by actuation with fixed or portable electrically, hydraulically or manually operated devices;
  - Allows notification of the over-full state of the containers.

INVENTORS: ALEXANDRU BĂLOI, ADRIAN PANĂ, FLORIN MOLNAR-MATEI

PATENT NO. RO 133454 B1/ 2023

## METHOD AND AUTOMATIC SYSTEM FOR COMPENSATION AND PROTECTION OF CAPACITOR BANKS



- The invention refers to a method and an automatic compensation and protection system that can be used for the protection of capacitor banks, installed for the compensation of reactive powers in power distribution networks operating under harmonic conditions, against the effects of parallel resonances.

- The method of capacitor banks protection against the harmonic conditions uses the voltages and currents values measured in the network and the value of the neutral power factor and is composed of the following steps:

- The active power, the reactive power and the power factor, are calculated;

- An additional resistive load is connected to the compensation bus and a new set of voltages and currents is measured in the compensation bus;

- The harmonic impedance of the network in the compensation bus is calculated based on the two sets of measurements;

- Based on the harmonic impedance values, the UBC and IBC values of the voltage and current at the terminals of the capacitor bank are calculated in advance, and compared with the maximum values allowed,  $UBC_{max}$  and  $IBC_{max}$ , corresponding to the capacitor bank;

- If the maximum values are exceeded, the previous procedure is repeated for a lower step of the capacitor bank, until UBC and IBC fall within the admissible limits and the connection of the corresponding step of the capacitor bank is done in the compensation bus.

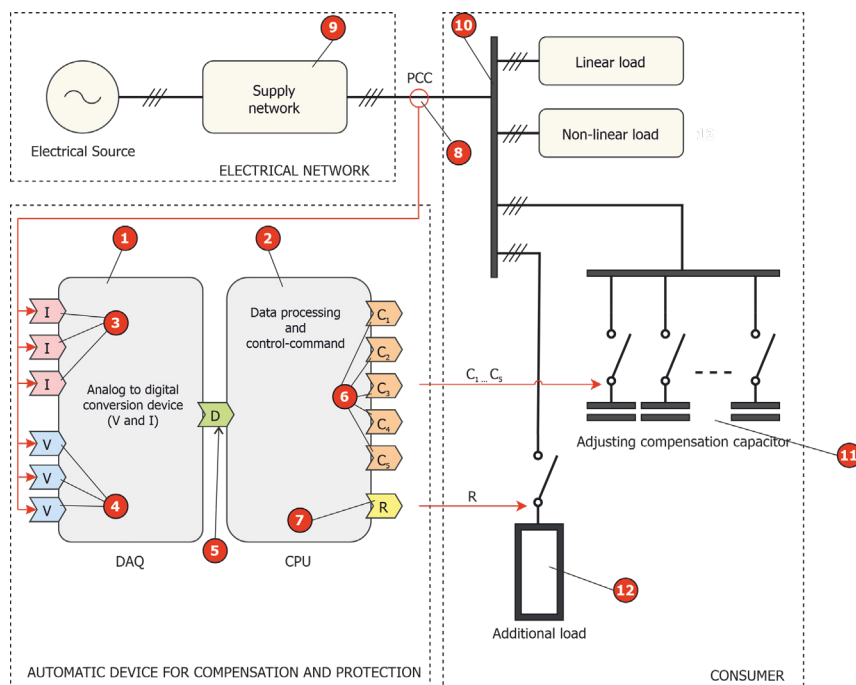

# DOCTOR HONORIS CAUSA





## DOCTOR HONORIS CAUSA

Dr. Christian Albrich von ALBRICHSFELD, Country Head of Continental Romania



- **Dr. Christian Albrich von Albrichsfeld** was born on January 27, 1966 in Brasov, and earned the Dipl.-Eng degree in Electrical Engineering and Automation at Technische Hochschule Darmstadt in 1992.
- During April 1992-June 1997 he devoted himself to doctoral studies at Darmstadt Technical University, obtaining the title of doctor following his doctoral thesis with the title „A Contribution to a Self-Adjusting Active Compliance Controller for Multiple Robots handling an Object”, in 1997. During the same period he worked as a research assistant at the Faculty of Systems Theory and Robotics.
- He started his career in the industry at Continental Group, Frankfurt, Germany, in 1997, as „development engineer”, in February 2009 becoming General Manager and R&D Head of Continental Automotive Romania. Since 2013 he has also held the position of **Country Head of Continental Romania**, simultaneously with his operational function.
- **Dr. Christian Albrich von Albrichsfeld** has authored more than 70 publications, lectures and debates, 23 patents published worldwide, and his entire activity was recognized internationally by numerous awards and distinctions, including Honorary Professor of the Politehnica University Timisoara, in 2012.

- **Dr. Christian Albrich von Albrichsfeld** has constantly promoted the collaboration between **Continental Timisoara** and **UPT**, being in constant contact with the academic environment over the years.
- As a member of the **UPT Steering Committee**, he has contributed substantially to defining the general lines that the university has followed over the years, to the establishment and equipping of numerous laboratories through sponsorship from Continental, and to the participation in scientific events such as international conferences and workshops.
- The partnership between UPT and Continental, facilitated by **Dr. Christian Albrich von Albrichsfeld**, contributed to the integration of industrial know-how into the educational act.
- Also, many students have benefited from Continental scholarships and numerous undergraduate, dissertation and doctoral dissertation papers have been focused on topics proposed and supported by the company.

## DOCTOR HONORIS CAUSA

Maestro Ioan HOLENDER, musician, baritone, artistic manager and Austrian Opera manager, originating from Romania



- **Maestro Ioan Holender** was born in Timisoara on July 18, 1935, to a family of wealthy Jews.
- His „unhealthy” origin blocked his access to the Faculty, so he joined the Electrical Plant – became a driver of technical service trams. This was how he escaped his bourgeois origin, being then accepted at the Polytechnic Institute – Faculty of Mechanical Engineering, section of rolling stock.
- In 1956, as a third-year student, he actively participated in the students’ riots, being expelled with the ban on entering college in Romania. To make a living, he became a tennis coach at the sports school, at the CFR and at a military unit.
- In 1959, his father applied for immigration to Israel, obtaining permission to leave via Vienna. Adapting to Vienna proved difficult in the beginning period (and obtaining the right to stay there). He tried to continue his studies but did not succeed. He worked as a technical draughtsman. He began to go to the Opera and Burgtheater (obviously, to “Stehplatze”), where he also did figuration and directing assistance. Tennis helped him integrate. For three years he studied music, in 1962 becoming a certified baritone. His first roles in this new quality were at St. Paul. Polten and Wiener Neustadt.
- In 1964 he was employed at the Stadttheater in Klagenfurt, and made a number of appearances at the famous Wiener Konzerthaus. In 1966 Ioan “Holi” Holender (as he appeared on the poster) **was invited to the Opera in Timisoara**, being lovingly received by the Timisoara public.
- Upon his return to Austria, he decided to give up his career as an opera soloist and joined the „Starka” agency, becoming a well-known name among opera managers and artists. In 1972 he took over the agency, which became the „Holender Artistic Management Agency”. This position allowed him to enlarge his circle of friends – opera managers, soloists, conductors, among them -Eberhard Waechter, director of Volksoper in Vienna.
- Following the 1992 death of the Director of Staatsoper and Volksoper – Eberhard Waechter, Ioan Holender was appointed director of the two operas, which position he held for 3 terms (19 years).
- In 2003 he accepted the invitation to be **Honorary President of the „George Enescu” Festival**, and from 2005 he became artistic director of the festival for the next 5 editions. In this position he contributed to the revitalization of the festival, the 2015 edition being sold out in just a few seconds.

## DOCTOR HONORIS CAUSA

Professor Ioan VIDA-SIMITI, Technical University of Cluj-Napoca, Romania



- **Professor Ioan Vida-Simiti** was born on the 6<sup>th</sup> of July, 1949, in Satu-Mare County.
- Between 1967-1972, he attended the Timisoara Polytechnic Institute (now Politehnica University Timisoara) in the specialization Machine Building Technology.
- In 1985 he obtained the title of doctor at the Technical University of Cluj-Napoca, with the thesis entitled: „Contributions to the elaboration of the technology of obtaining and the study of the properties of thin porous sheets of metal powders”.
- Between 1990-1995 he was a lecturer and then associate professor, and in 1995 he became Professor at the Technical University of Cluj-Napoca (since 2014 - Associated Professor). During his didactic activity, **Professor Ioan Vida Simiti** lectured on subjects within the bachelor and master cycle, such as Powder Metallurgy, Eco-friendly materials and technologies, porous materials.
- Being a founding member of the Romanian Powder Metallurgy Society (in 1990), **Professor Ioan Vida-Simiti** has distinguished himself by his exceptional contributions in this field. His research had a high degree of applicability materialized by submitting patent applications and winning prizes at invention salons, and we should mention here the procedures for obtaining high porosity sintering sheets or tubular parts.
- From 2007 until now, **Professor Vida-Simiti** is a member of the permanent commission ARACIS „Engineering sciences 1” as an expert evaluator, for the purpose of provisional authorization, accreditation, being responsible for over 75 evaluation teams and 6 institutional evaluations.
- **Professor Vida Simiti** is the co-author of 17 books in the fields „Material science and engineering”, and „Industrial engineering”, respectively, and author and co-author of over 300 articles and scientific papers published in specialized journals and press releases.
- Between **Politehnica University Timisoara** and **Professor Ioan Vida Simiti** there has been a long-term collaboration both in the fields of education and research. Among the research collaborations, we mention the partnership on research projects from the National Research Development Innovation Plan (the professor being the representative of his university for this program) in the field of **new and advanced materials**.

## DOCTOR HONORIS CAUSA

Academician Dorel BANABIC, Technical University of Cluj Napoca, Romania



- Academician **Dorel Banabic** was born on October 3, 1956 in Ciceu-Giurgesti, Bistrita-Nasaud County. He attended Andrei Muresan High-School in Dej, and continued his studies at the Polytechnic Institute of Cluj-Napoca, Faculty of Mechanical Engineering, Department of Machine Building Technology, which he graduated in 1980.
- He became a teacher at the Polytechnic Institute of Cluj-Napoca in 1984, going through all the hierarchical steps and becoming Professor in 1996.
- **Academician Dorel Banabic** also carries out an activity supported by academic and scientific management, both within the Technical University of Cluj-Napoca and nation wide, where he is vice-president of the National Council for the Attestation of Titles, Diplomas and University Certificates (CNATDCU).
- Between 2006–2014, **Academician Dorel Banabic** was a member of the Presidential Commission for the Analysis and Development of Education and Research Policies, member of CNCIS and CNCS. During 2011–2016 he was a Member of the CCCDI and of the National Agency for Scientific Research (ANCS).
- The international recognition of academician **Dorel Banabic** is certified by him being elected as president of the highest European scientific forum in the field of plastic deformation, the European Association of Materials Deformation (ESAFORM), in 2012–2016.
- In 2009, in recognition of his scientific activity, **Dorel Banabic** became a **corresponding member of the Romanian Academy, and a full member thereof in 2015.**
- Following his work and scientific results, the **academician Dorel Banabic** won numerous awards, including the Traian Vuia Prize of the Romanian Academy (2002), European Commission Leonardo da Vinci Prize (2006), Lee Hsun Award of the Shenyang Institute of Metal Research of the Chinese Science Academy (2015) and National Order „Romanian Star” as Knight in December 2016.
- The collaboration of the **academician Dorel Banabic** with the Politehnica University Timisoara began in 1986 by attending the conference organized by the department of Machine Building Technology through its Deforming Technologies team, and continued over the years through the support and promotion of the teaching staff of the Politehnica within the Romanian Academy and in bodies of the Ministry of Education and the Ministry of Research.

## DOCTOR HONORIS CAUSA

Professor Emeritus Anton ANTON, Technical University of Civil Engineering of Bucharest, Romania



- **Professor Anton Anton** was born in Timișoara, on December the 22<sup>nd</sup>, 1949.
- He carried out his studies in Timisoara, namely, the first 4 classes at Elementary School 15 (1955-1959) in German, then (1959-1967) at the "Constantin Diaconovich Loga" Lyceum. He graduated from the Faculty of Mechanical Engineering in June 1972, obtaining maximum grade and a Diploma of Merit.
- He became a teacher at the Bucharest Institute of Civil Engineering, the current Technical University of Civil Engineering in of Bucharest, where he successively occupied all teaching positions until the title of university professor, working until 2016 when he became **emeritus professor**.
- The national and international recognition of **Professor Anton Anton's merits** came through his election or appointment in the following positions: between 1993 - 1997 and 2002 - 2004, president of JHU - International Urban Fellows Association, with headquarters at the "Johns Hopkins" University from Baltimore, USA;
- Vice president of the Technical and Scientific Committee of the Romanian Association of Water and in the same time president of the section "Pumping, stockage and transport networks", between 2008-2014; between 1997 - 2000, member of IUHER (Implementation Unit of Higher Education Reform);
- Between 1998-2004, president of the technical sciences commission within CNSIS; between 1972 - 2003, Head of the Laboratory of Hydraulics of the Technical University of Civil Engineering of Bucharest
- Between 2016 - 2020, Deputy in the Romanian Parliament;
- Between 2017 - 2018, Ministry of Energy;
- Between 2013 - 2016, member of Membru CCCDI, president of the commission for the promotion of technical and scientific literature;
- Between 2013 - 2016, president of CNSPIS (National Council for the Statistics and Prognosis in Higher Education);
- Between 2012 - 2016, President of the Senate of UTCB;
- Between 2008 - 2012, Vicerector of UTCB;
- Between 2008 - 2008, Minister of Education, Research and Youth;
- Between 2006 - 2008, president of the National Authority for Scientific Research;
- Between 2005 - 2006, Secretary of State in the Ministry of Education and Research.
- The research-development and innovation activity (RDI) of **Professor Anton Anton** also materialized by his participation in a series of scientific events.
- Among these, which is an honour for us and a soul connection, he participated in all the international conferences on Hydraulic Machines and Ferrofluids organized at UPT Timisoara.



# HABILITATION THESIS





## INNOVATIVE METHODS IN COLD PLASTIC DEFORMATION PROCESSES, IN THE DESIGN OF COORDINATE MEASURING MACHINES AND IN THE QUALITY ASSURANCE OF PARTS BY THREE-DIMENSIONAL MEASUREMENT

Author: Aurel TULCAN

### Abstract

- The habilitation thesis is in the **Industrial Engineering** domain and presents the most important topics and fields covered by the author after completing his doctoral studies. The habilitation thesis is structured in three parts.
- The **first part** presents an overview of the author's scientific, academic, and professional achievements. Research is grouped in two main areas: **cold plastic deformation manufacturing processes and technologies**, as a continuation of the research carried out within the PhD thesis, and three-dimensional measurements.
- The **research area of three-dimensional measurements**, implemented for the first time at Politehnica University Timisoara by the author of this habilitation thesis, has been developed since 2000 in two directions: the design and performance verification of Coordinate Measuring Machines (CMMs) and the quality assurance of the injected and 3D printed parts by three-dimensional measurement procedures.
- Research results are presented in the form of scientific articles, patents, published books, and research contracts. The professional prestige of the author of this habilitation thesis is validated by the national and international impact of the published books, the results of research contracts and the published scientific papers, and the CMM models designed by the author, built in Germany and Romania, displayed at International Fairs and sold in Europe and Japan.
- The **second part** details the author's scientific achievements. **Chapter 2.1** presents issues related to the automation of cold-forming manufacturing processes. The operation modes of a flexible automatic cold-pressing line were defined, and the research continued with modelling the operation control unit using the GRAFCET functional diagram.
- In order to improve the setting operation of an automatic line, the principles of the S.M.E.D method were used and applied. In the second part of this chapter, the results of an experimental investigation on the autofrettage parameters of the artillery tubes, for the UM Reșița company, were presented.
- **Chapter 2.2** deals with issues related to the design and performance verification of Coordinate Measuring Machines.



- The research results are presented during the design phase of the Presingo 755, NovaBernath 565 and Tesa343 Coordinate Measuring Machines. Dynamic performance at high speeds and variable thermal field studies were performed by using the Ansys finite element analysis software. The research was continued with several studies on the measurement uncertainty of CMMs for different configurations and orientations of the resistive touch trigger probe system.
- **Chapter 2.3** presents more research on quality assurance of injected and 3D printed parts using 3D measurement procedures. Several strategies for measuring geometric elements of plastic injected parts that may exhibit high-dimensional and geometric deviations were also presented.
- The **third part** presents an overview of the author's plans for career development as well as the main research direction proposed by the author to possible candidates for PhD students.

The full abstract at:

[http://www.upt.ro/img/files/2021-2022/doctorat/abilitare/Tulcan/Rezumat\\_abilitare\\_Tulcan%20Aurel\\_en.pdf](http://www.upt.ro/img/files/2021-2022/doctorat/abilitare/Tulcan/Rezumat_abilitare_Tulcan%20Aurel_en.pdf)

### Habilitation Commission

- Prof. Dr. Eng. Titus SLAVICI**  
Politehnica University Timisoara, President
- Prof. Dr. Eng. Nicolae BÂLC**  
Technical University of Cluj-Napoca, Member
- Prof. Dr. Eng. Gheorghe OANCEA**  
Transilvania University of Brașov, Member

**Author: Maria Anastasia JIVULESCU**

### Abstract

• This thesis was written for the title of Habilitation of Technical University of Cluj-Napoca, fundamental field: **Mathematics and Natural Sciences, Speciality Mathematics.**

• The main objective of this thesis is to provide the most important scientific, professional and academic achievements of its author, after January 2008, when the author defended the Ph.D. thesis, up to today.

• The field of research of the author is represented by the applications of mathematics (Operator Theory, Algebras of Operators, Linear Algebra, and Random Matrix Theory) in Quantum Information Theory. The author published 23 journal papers on different QIT topics. The author was principal investigator of one research grant (2013-2016) won by national competition.

• The thesis is organized around two fundamental topics from QIT, that are the theory of entanglement criteria and the theory of quantum measurements, the author's contributions to the development of these subjects is described in Chapters 3,4,5,6,7.

• For a complete picture of the mathematics theory used in QIT, the author presents in Chapter 2 the main notions and tools from QIT used in this thesis. Therefore, the main concepts of QIT are recalled by its postulates, whereas the state-of-the-art on entanglement criteria and quantum measurements is summarized.

• Chapters 3 and 4 present the author's contributions to the development of the theory of entangled/separable states, using analytical methods (coming from Operator Theory, Operator Algebras) or more sophisticated methods, such as the ones coming from Random Matrix Theory.

• Here, the author's results on unifying the entanglement criteria using tensor norms are mentioned; see Chapter 3, or different characterization of  $A$ -sets, from the analytical point of view or studying their volume, using different approximations.

• Consequently, thresholds for entanglement criteria are derived and comparisons between them are done.



• Chapters 5, 6 and 7 are based on the author's studies on quantum measurements and the results of their structure, their properties and methods to generate random POVMs are presented.

• Finally, the thesis ends with the future work plans of the author in Chapter 8.

**The full abstract at:**

<https://iosud.utcluj.ro/teze-de-abilitare.html>

### Habilitation Commission

**Prof. Dr. Aurelian GHEONDEA**

Bilkent University Ankara Turkey, IMAR Bucharest, Romania

**Prof. Dr. Mirela KOHR**

"Babeş-Bolyai" University Of Cluj Napoca

**Prof. Dr. Ioan RAŞA**

Technical University of Cluj-Napoca

# PhD THESIS



## Systems Engineering

**Dorin BORDEAȘU**  
PhD adviser prof. O.PROȘTEAN

*Modelarea, simularea și conducerea unui sistem de pompare izolat alimentat de surse de energie regenerabile*  
(Modelling, simulation and control of an isolated pumping system powered by renewable energy sources)

## Computers and Information Technology

**Laura BROASCĂ**  
PhD adviser H. CIOCĂRLIE

*Țipare în bioinformatică*  
(Patterns in Bioinformatics)

**Adriana-Maria BERDICH**  
PhD adviser B. GROZA

*Amprentarea telefoanelor mobile folosind traductoarele încorporate*  
(Fingerprinting Smartphones From Embedded Transducers)

**Stelian-Nicolae NICOLA**  
PhD adviser L. STOICU-TIVADAR

*Contribuții la interacțiunea multimodală în 3D*  
(Contributions to Multimodal Interaction in 3D)

**Lucian-Tudor POPA**  
PhD adviser B. GROZA

*Securitate la nivel fizic folosind caracteristici de timp și tensiune pentru magistrala Controller Area Networks*  
(Physical Layer Security based on Timing and Voltage Features for Controller Area Networks)

**Camil-Vasile JICHICI**  
PhD adviser B. GROZA

*Sisteme de detecție a intruziunilor pentru magistrale CAN din vehicule comerciale cu comunicație bazată pe SAE J1939*  
(Intrusion Detection Systems on CAN Buses for Commercial Vehicles with SAE J1939 Compliant Communication)

## Chemical Engineering

**Diana-Aylin CĂPRARU**

PhD adviser prof. C.PĂCURARIU

*Materiale cu proprietăți controlate pe bază de nanoparticule magnetice utilizate în terapia cancerului și protecția mediului*

(Advanced materials based on magnetic nanoparticles used in biomedical and environmental applications)

**Delia DUCA**

PhD adviser prof. N.VASZILCSIN

*Utilizarea medicamentelor neconforme ca inhibitori în procese electrochimice*

(Uncompliant drugs as inhibitors in electrochemical processes)

**Cristina Teodora ARDEAN**

PhD adviser prof. C.M. DAVIDESCU

PhD adviser prof. A.G. NEGREA

*Noi materiale cu proprietăți antimicrobiene dirijate, derivate din polimeri naturali*

(New materials with targeted antimicrobial properties derived from natural polymers)

**Ioan-Bogdan PASCU**

PhD adviser prof. A.G. NEGREA

*Nanostructuri de argint: sinteză chimică, caracterizare și aplicații*

(Silver nanostructures: chemical synthesis, characterisation, and applications)

**Nick Samuel ȚOLEA**

PhD adviser prof. R. PODE

*Materiale modificate chimic cu lichide ionice aplicate în tratarea apelor reziduale*

(Chemically modified materials with ionic liquids applied in wastewater treatment)

**Melinda VAJDA**

PhD adviser prof. N.M. DUȚEANU

*Contribuții la îmbunătățirea celulelor solare sensibilizate cu colorant*

(Contributions to the improvement of dye-sensitized solar cells)

**Bianca-Beatrice BAUL**

PhD adviser prof. F. PETER

*Contribuții privind studiul preformulării unor substanțe bioactive cu aplicații în tehnologia farmaceutică modernă*

(Contributions concerning the preformulation of some bioactive compounds used in modern pharmaceutical technology)

**Ioan BÎTCAN**

PhD adviser prof. F. PETER

*Sisteme biocatalitice pentru sinteza și caracterizarea unor bioderivați sustenabili*

(Biocatalytic systems for synthesis and characterization of sustainable bioderivatives)

**Elena Adela SELEJAN**

(married Manea)

PhD adviser prof. D.M. PERJU

*Contribuții la îmbunătățirea indicatorilor de calitate ai produselor cosmetice cu ingrediente naturale utilizând tehnici de modelare matematică și simulare numerică*

(Contributions concerning the improvement of quality indicators of cosmetic products with natural ingredients using mathematical modeling techniques and numerical simulation)

## Civil Engineering and Building Services

**Mihaela Ivona GURAN**

(married COJOCINESCU)

PhD adviser prof. T.E. MAN

*Evoluția în timp a amenajărilor de îmbunătățiri funciare în România*

(Evolution of land improvement arrangements in Romania)

**Daniel Mihai MUNTEAN**

PhD adviser prof. D.V. UNGUREANU

*Soluții sustenabile de reabilitare energetică a clădirilor de locuit*

(Sustainable solutions for extensive retrofitting of residential buildings)

<b>Zsolt MAROSSY</b> PhD adviser prof. I. DAVID	<i>Studiul pierderilor de sarcină locale în sisteme hidraulice cu armături de tip HAWLE</i> (Study of local head losses in hydraulic systems with hawle fittings)
<b>Rafaela DON</b> PhD adviser prof. A. CIUTINA	<i>Performanța seismică a structurilor multietajate în cadre cu noduri grindă-stâlp de tip slim-floor</i> (Seismic performance of multi-storey frames with slim-floor beam-to-column joints)
<b>Alexandru-Adrian DORCA</b> PhD adviser prof. I. SÂRBU	<i>Asigurarea eficienței energetice a sistemelor termice și a confortului în clădiri civile utilizând pompa de căldură cuplată la sol</i> (Ensuring the energy efficiency of thermal systems and comfort in civil buildings using the ground-coupled heat pump)
<b>Diana-Maria DUMA</b> PhD adviser prof. R. ZAHARIA	<i>Comportarea îmbinărilor metalice cu șuruburi sub acțiuni extreme</i> (Behaviour of steel bolted connections under extreme actions)
<b>Raluca Ioana LEGIAN</b> (married BUZATU) PhD adviser prof. A.L. CIUTINA	<i>Comportarea sustenabilă a clădirilor cu sisteme metalice de fațadă</i> (Sustainable behaviour of buildings with steel-intensive facade systems)

## Electrical Engineering

<b>Diana-Raluca BIBA (married POPA)</b> PhD adviser prof. S. MUȘUROI	<i>Contribuții privind proiectarea circuitelor aferente unității electronice de control al transmisiei automate din domeniul automotive</i> (Contributions to main circuits design used in transmission control unit in automotive domain)
<b>Adrian Daniel MARTIN</b> PhD adviser prof. L. N. TUTELEA	<i>Observatoare de cuplu îmbunătățite și încărcare virtuală pentru mașini de inducție în aplicații industriale bazate pe controlere integrate în timp real</i> (Improved induction machine torque observers and virtual loading in industrial applications, based on real-time embedded controllers)

## Electronic Engineering Telecommunications and Information Technologies

<b>Petru-Adrian BUTA</b> PhD adviser prof. A. DE SABATA	<i>Contribuții la proiectarea Suprafețelor Selective în Frecvență cu aplicații în Compatibilitate Electromagnetică</i> (Contribution to the design of Frequency Selective Surfaces with applications in Electromagnetic Compatibility)
<b>Bogdan Ilie SIGHENŢEA</b> PhD adviser prof. C. D. CĂLEANU	<i>Utilizarea rețelelor neuronale profunde în predicția deplasării participanților la traficul rutier</i> (Using deep neural networks in predicting the movement of road users)
<b>Cristina Laura SÎRBU</b> PhD adviser prof. C. D. CĂLEANU	<i>Sistem de diagnostic asistat de calculator pentru investigația leziunilor focale hepatice prin metoda ecografică cu substanță de contrast</i> (Computer Aided Diagnosis System for CEUS Focal Liver Lesion Investigation)
<b>Corina-Nicoleta COVACI (married Vidoni)</b> PhD adviser prof. A. GONTEAN	<i>Contribuții la reducerea zgomotului acustic generat de condensatoarele ceramice multistrat în modulele electronice automotive</i> (Contributions to the reduction of the acoustic noise generated by multilayer ceramic capacitors in automotive electronic modules)

**Sebastian AVRAM**  
PhD adviser prof. R.A. VASIU

*Tehnici de îmbunătățire a performanțelor comunicației prin liniile de alimentare cu energie electrică de joasă tensiune*  
(Methods for Enhancing Power Line Communication over Low Voltage Networks)

## Engineering and Management

**Adelin Emanuel TRUȘCULESCU**  
PhD adviser prof. A. DRĂGHICI  
PhD adviser prof. C.T. ALBULESCU

*Evaluarea afacerilor de-a lungul ciclului de viață al industriei: focalizarea pe domeniul afacerilor activate de Internet*  
(Business valuation across the industry life cycle: focus on internet - enabled businesses)

**Gabriela Alina FILIP**  
(Married PARASCHIVA)  
PhD adviser prof. A. DRĂGHICI

*Contribuții și implicații privind dezvoltarea conceptului de organizație care învață*  
(Contributions and implications on the learning organization concept development)

**Edwald-Viktor GILLICH**  
PhD adviser prof. M. L. MOCAN

*Contribuții privind stabilirea traseului de implementare a conceptului Industry 4.0 în cadrul firmelor mici și mijlocii*  
(Contributions on establishing the implementation pathway of the Industry 4.0 concept in small and medium-sized companies)

**Michael GLOWINKEL**  
PhD adviser prof. M. L. MOCAN

*O analiză comparativă a întreprinderilor agricole regionale din România și Germania ca bază pentru dezvoltarea posibilităților unei politici eficiente de subvenții a UE la nivel regional*  
(A comparative analysis of regional agricultural enterprises in Romania and Germany as a basis for developing possibilities of an effective EU subsidy policy on a regional level)

**Iudit SEMEREDI**  
(married BERE - SEMEREDI)  
PhD adviser prof. A. DRĂGHICI

*Cercetări privind elaborarea strategiilor de mediu în contextul schimbărilor climatice*  
(Research on the development of environmental strategies in the context of climate change)

**Diana Florina MILOVAN CIUTA**  
(married ROBESCU)  
PhD adviser prof. A. DRĂGHICI

*Managementul competențelor profesionale și implicațiile sale asupra performanței organizaționale*  
(Professional competence management and its implications for organizational performance)

**Nicoleta Paula POPESCU**  
(married NEAG)  
PhD adviser prof. A. DRĂGHICI

*Managementul activităților de prevenire și protecție în contextul sănătății ocupaționale*  
(Management of prevention and protection activities in the context of occupational health and safety)

**Ciprian TROCAN**  
PhD adviser prof. M.L. MOCAN

*Contribuții privind îmbunătățirea managementului administrației locale*  
(Contributions on improving local government management)

**Ovidiu Marcel SÎRBU**  
PhD adviser prof. M.L. MOCAN  
PhD adviser prof. S. HERBAN

*Contribuții privind actualizarea strategiei de dezvoltare a sistemului de transport terestru din România*  
(Contributions regarding the updating of the terrestrial transportation system development strategy in Romania)



## Mechanical Engineering

**Adriana Raluca AVRAM**  
(Married WACHTER)  
PhD adviser prof. I. IONEL

*Valorificarea energetică a deșeurilor din industria alimentară*  
(Energy recovery of waste from industry)

**Robert KRISTOF**  
PhD adviser prof. I. MANIU

*Sistem neconvențional de conducere a roboților industriali*  
(Unconventional system to control industrial robots)

**Cristina VĂLEAN (married LINUL)**  
PhD adviser prof. L. MARȘAVINA

*Integritatea și durabilitatea componentelor obținute prin printare 3D*  
(The integrity and durability of 3D printed components)

**Ralph-Alexandru ERDELYI**  
PhD adviser prof. V.F. DUMA

*Imagistică biomedicală în stomatologie și NDT folosind o gamă de tehnici de investigare, cu focus pe tomografia în coerență optică (OCT)*  
(Biomedical imaging in dentistry and NDT using a range of investigation techniques, focusing on optical coherence tomography (OCT))

**Alexandru Lucian DÎMB**  
PhD adviser prof. V.F. DUMA

*Contribuții la studiul scannerelor laser cu prisme risley pentru tomografia de coerență optică, cu aplicații în măsurătorile industriale*  
(Contributions to the study of laser scanners with risley prisms for optical coherence tomography with applications in industrial measurements)

**Raul-Alexandru SZAKAL**  
PhD adviser prof. S. MUNTEAN

*Investigații ale câmpului hidrodinamic în conul de aspirație al turbinelor hidraulice și controlul curgerii cu dispozitiv magneto-reologic*  
(Investigations of the hydrodynamic flow field in the draft tube cone of the hydraulic turbines and the flow control with a magneto-rheological device)

**Tamas KRAUSZ**  
PhD adviser prof. L. MARȘAVINA

*Evaluarea integrității și durabilității materialelor plastice din industria automotive*  
(Evaluation of integrity and durability of plastic materials from the automotive industry)

**Iulia-Eliza ȚINCA**  
PhD adviser prof. A. DAVIDESCU

*Cercetări privind durata de viață a pastei de lipit în cazul componentelor montate la suprafață*  
(Research on solder joint lifetime of surface-mounted devices)

## Materials Engineering

**Oana Izabela LUPU**  
(married SOCOL)  
PhD adviser prof. A.V. SOCALICI

*Valorificarea deșeurilor mărunte rezultate din procesul de elaborare și procesare a oțelului*  
(The recovery of small waste resulted from the process of steel manufacturing and processing)

**Flavius BUCUR**  
PhD adviser prof. A.V. SOCALICI

*Fonte de calitate superioară utilizate la sistemele de frânare a materialului rulant*  
(High quality cast iron used in rolling stock braking systems)

**Mircea Daniel NICOLAESCU**  
PhD adviser prof. V.A. ȘERBAN

*Dezvoltarea de materiale heterostructurale pentru aplicații în senzorială*  
(Development of heterostructural materials for sensor applications)

## Industrial Engineering

**Petre-Florinel NENU**

PhD adviser T. SLAVICI

*Contribuții la optimizarea procesului de fabricație a peleiților/brichetelor și arhitecturii centralei termice pentru arderea acestora*

(Contributions to the optimization of the manufacturing process of pellets/briquettes and the architecture of the heating plant for their combustion)

**Maria HUMIȚA**

PhD adviser M. JĂDĂNEANȚ

*Studiul termomecanic privind încălzirea centralizată (termoficare) versus încălzirea locală cu centrale de apartament*

(The thermomechanical study on central heating (thermal heating) versus local heating with apartment central heating)

**Alexandra-Ionela ȘUTA**

PhD adviser T. SLAVICI

*Optimizarea echipamentelor și proceselor tehnologice de tăiere și mărunțire a biomasei în vederea fabricării peleiților și brichetelor*

(Optimizing equipment and technological processes for cutting and shredding biomass for pellet and briquette manufacturing)

# SCIENTIFIC CONFERENCES



## SIRAMM23

### International Conference on Structural Integrity and Reliability of Advanced Materials obtained through Additive Manufacturing (SIRAMM23)

8-11 March 2023, Central Library of Politehnica University Timisoara, Romania (organized in hybrid mode)

**Organizer(s):** • SIRAMM project, No. 857124, Politehnica University Timisoara (ROMANIA),  
• University of Belgrade (SERBIA), • Institute of Physics of Materials, Brno, (CZECH REP.),  
• University of Parma ITALY), • NTNU (NORWAY)

Web: [https://www.siramm.unipr.it/Conference\\_SIRAMM23.htm](https://www.siramm.unipr.it/Conference_SIRAMM23.htm)

The general aim of the conference is to promote international collaboration and share the current knowledge on the structural integrity of additively manufactured materials and the related disciplines. Of particular interest is the understanding of the role of the AM printing conditions and parameters on the final reliability and safety of AM materials, especially those to be used in load bearing applications.

The conference is open to any contribution addressing the problem of characterizing AM materials for traditional as well as for advanced applications in a broad range of technological fields.

Conference main topics:

- Structural integrity assessment of AM components; • Mechanical and fracture testing of AM materials
- Fatigue, durability, and reliability of AM materials; • AM and 3D printing advanced technologies;
- Simulation of AM processes; • Design of AM parts & process optimization;
- Theoretical and numerical models for AM materials; • Advanced AM materials and structures; • Composite AM materials

#### Publication of papers:

Conference Proceedings will be published in a dedicated issue of the open access Journal **Procedia Structural Integrity**



### Professional Communication and Translation Studies: Digital Culture, Communication and Translation

30-31 March 2023, On-site and virtual conference, Timișoara, Romania

**Organizer(s):** • Department of Communication and Foreign Languages, Politehnica University Timisoara

Web: <https://sc.upt.ro/ro/home-pcts>

The international conference **Professional Communication and Translation Studies (PCTS)** has been organized by the Department of Communication and Foreign Languages since 2001.

The conference focuses traditionally on the following topics:

- Communication and public relations: theoretical and didactic problems and solutions;
- Linguistic insights into professional communication;
- Given the success of the previous conferences, the 13<sup>th</sup> edition of the conference aimed to continue the exchange of ideas on the impact of new technologies on communication, to highlight the evolution of humanities and social sciences in conjunction with technological innovation, and to identify (new) trends in the language industry in the post web 2.0 era.
- The languages of publication are **English, French or German.**
- Translation theory and translation didactics: their roles in communication;
- Foreign language teaching.

#### Publication of papers:

- Selected papers published in the volume **Professional Communication and Translation Studies** (peer-reviewed, indexed by EBSCO, Index Copernicus, CEEOL, Fabula, Google Scholar, WorldCat) or in the **Scientific Bulletin of Politehnica University Timisoara, Transactions on Modern Languages** (peer-reviewed, indexed by CEEOL, EBSCO, ERIHPLUS, Europeana, Google Scholar, MLA, ULRICH'S and WorldCat).



**Smart Diaspora: Diaspora in higher education, science, innovation and entrepreneurship. Diaspora and its friends – 2023**

**Workshop: Education Digitalization through AR/VR/XR and Blockchain Technologies**, 10-13 April 2023, Room C 401, Department for Digital Education

**Organizers:** • UEFISCDI and • Politehnica University Timisoara –Department for Digital Education and the Research Center for Multimedia

<https://www.diaspora-stiintifica.ro/workshopuri/digitalizarea-educatiei-prin-tehnologii-ar-vr-xr-si-blockchain> and <https://elearning.upt.ro/en/event/smart-diaspora-2023-workshop-ar-vr-blockchain/>

• The workshop addressed AR/VR/XR and blockchain technologies from the perspective of how they can contribute to the modernization of the educational process, adding digital components and increasing the degree of interactivity.

From the point of view of applicability, **3 areas were addressed:**

- Education, with an emphasis on the use of AR/VR/XR technologies for the efficiency and increase of the attractiveness of the learning process, as well as for the blockchain validation of university degrees and competencies generated on the basis of micro-credentials
- Culture, with an emphasis on the development of interactive applications that facilitate, through AR/VR/XR techniques, for various target groups
- The development of sustainable and smart regions, with an emphasis on the basic pillars of a smart city / smart region, the sustainable development of smart cities / regions, smart learning and the smart campus versus smart city, cultural and creative industries as the engine of smart cities.

• No publication. Presentations are available and can be freely downloaded from the conference website, at

<https://www.diaspora-stiintifica.ro/workshopuri/digitalizarea-educatiei-prin-tehnologii-ar-vr-xr-si-blockchain>



## **Building Services and Environmental Comfort (ICCA 2023)**

May 4-5, 2023, UPT Library – Auditorium, K1 and K2, Bv. Bd. Vasile Pârvan 2, Timișoara 30022

(Participation physical and online, through the ZOOM application)

**Organizers:** • AIIR – Romanian Association of Building Services;

• Politehnica University Timișoara – Department of Civil Engineering and Building Services Engineering

Web: <http://www.aiir-timisoara.ro>

• In the technical field and beyond, all knowledge must have a useful completion. The need and the opinion, that is, the need and the approximate, must be brought to certainty through scientific research and applicability (which can be, why not, the ambient comfort to “prove” the motto of the conference “MENS SANA IN DOM O PULCHRA”). Existentially, defined by past, present and future, the 32<sup>nd</sup> edition of the ICCA conference (Construction Installations and Ambient Comfort) tried to bring it up to date, to make it present in the technique (interest) of installations.

• The topics addressed, essential and multiple, discussed/informative level stuff/techniques/performances provided a starting/continuing basis depending on the specifics/areas of interest of the participants. Programming and digitalization could not be missing; the conclusions were in favour of efficiency, safety, and security, ensuring by using of high-performance (and durable) materials, the optimization of all types of installations and equipment, compliance with the conditions of production, commissioning and use.

### **Publication of papers:**

• Conference Proceedings, Publishing House Matrix Rom, Bucharest, 2023, ISSN 1842-9491.

• Conference series “Building Services and Environmental Comfort”



## The 46<sup>th</sup> International Spring Seminar On Electronics Technology (ISSE 2023)

10<sup>th</sup> – 14<sup>th</sup> May, 2023 Timișoara, Romania

**Organizers:** • Faculty of Electronics, Telecommunications and Information Technologies, Politehnica University Timișoara, Continental Automotive Romania, DEERY BROOK SRL, The Association for Promoting Electronics Technology (APTE)

Web: <https://isse-conf.eu/>

Since its first celebration in 1977 the **International Spring Seminar on Electronics Technology ISSE** has always been a forum for students, professors, senior and junior researchers to come together in a unique forum to discuss scientific and educational topics and organize international cooperation in a convenient atmosphere. For numerous young scientists the ISSE is their first international conference experience.

Papers submitted to ISSE are carefully evaluated for oral and poster presentations by an internationally composed board of reviewers and active members of the ISSE Steering Committee. Since 2001 the ISSE is celebrated under the patronage of IEEE.

Topics of Interest:

- New Materials, Components and Processes
- Thermal Management
- Advanced Packaging and Interconnection Technologies
- Testing, Reliability and Quality Management
- Process Modelling and Simulation
- Environmental and Ecological Effects in Electronics Technology
- Nanotechnology, Nanomaterials and Nanoelectronics
- Signal Integrity and Electromagnetic Compatibility
- Sensors, Actuators and Microsystems
- Educational and Information Technologies in Electronics Manufacturing
- Discrete and Integrated Components

### Publication of papers:

Papers that met all quality criteria have been published and are available on IEEE Explore:

<https://ieeexplore.ieee.org/xpl/conhome/10168303/proceeding>

## SACI 2023

IEEE 17<sup>th</sup> International Symposium on Applied Computational Intelligence and Informatics

## IEEE 17<sup>th</sup> International Symposium on Applied Computational Intelligence and Informatics (SACI 2023)

May 23 - 26, 2023, Timișoara, Romania

**Organizers:** • Óbuda University, Budapest, Hungary, Politehnica University Timișoara, IEEE Chapter of Systems, Many, and Cybernetics Society, Romania

Web: <http://conf.uni-obuda.hu/saci2023/>

SACI 2023 has featured several kinds of presentations, including invited talks, contributed papers and posters. The outcome of SACI 2023 is a better understanding of some leading research areas, as already Computational Intelligence and Informatics have demonstrated.

SACI 2023 has welcomed papers on the following topics:

- Computational Intelligence,
- Intelligent Mechatronics,
- Systems Engineering,
- Intelligent Manufacturing Systems,
- Intelligent Control,
- Intelligent Robotics,
- Informatics.

### Publication of papers:

IEEE Xplore Digital Library, please visit:

<https://ieeexplore.ieee.org/xpl/conhome/10158523/proceeding>



## International Conference on Applied Sciences – ICAS2023

May 24–27, 2023, Hunedoara, Romania (face-to-face and on-line)

**Organizers:** • Politehnica University Timisoara and • University of Banja Luka, in cooperation with:  
• Ministry for Scientific and Technological Development, Higher Education and Information Society of the Republica Srpska, • Academy of Romanian Scientists, • Academy of Sciences and Arts of the Republica Srpska, • Academy of Technical Sciences of Romania – Timisoara Branch,  
• General Association of Romanian Engineers – Hunedoara Branch and • Association Universitaria Hunedoara  
Web: <http://icas.science/>

Topics of the conference covers a comprehensive spectrum of issues from:

- Fundamental Sciences
- Computers Engineering
- Electrical Engineering
- Mechanical Engineering
- Materials Engineering

### Publication of papers:

– Proceedings of ICAS 2023 has been submitted to be considered for publication in a forthcoming volume of the **Journal of Physics: Conference Series**.



## 20<sup>th</sup> International Conference NETTIES (Networking Entities) 2023 – Digital Society: Synergies between Arts, Culture and Digital Technologies

25–26 May 2023, Physically in the Auditorium of the UPT Conference Center, online through Zoom and Facebook

**Organizers:** Politehnica University Timisoara (Department for Digital Education and Research Center for Multimedia), IAFES – International Association for e-Science

Web: <https://iafes.net/events/conference/netties-conference-2023-timisoara-romania/> and <https://elearning.upt.ro/en/academic/netties-conference-2023-timisoara/>

**NETTIES 2023** brought together international experts in virtual and augmented reality technologies, digital cultural and educational applications, and digital transformation in the creative industries from Austria, the USA, Norway, Italy, Germany, Sweden, Finland, Portugal, Lithuania, Greece, and Romania.

The event provided participants with a platform for exchanging knowledge, experience, and innovative ideas to strengthen efforts for

- The conference was attended by more than 60 professionals in Timisoara and more than 150 online participants, and the presentations generated both interest and a series of questions and debates from participants.

### Publication of papers:

– Conference proceedings are under publication in Vienna by IAFES as volume 12 of the **IAFES Book Series**.

The book will also be available online on the IAFES site:

[www.iafes.net](http://www.iafes.net).

the integration of digital technologies in academia and the exploitation of their potential in support of users.

The conference featured 25 leading experts on topics highly relevant to digital technologies and education. The topics covered included the use of immersive AR/VR technologies, haptic technologies, artificial intelligence, and other digital technologies in the cultural and creative industries and in education to support users.



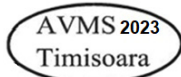

## Acoustics and Vibration of Mechanical Structures -AVMS 2023

26-27 May 2023, Timișoara, Romania, with physical and online attendance

**Organizers:** • Politehnica University Timisoara,  
• University of Niš -Serbia,  
• Romanian Academy Timisoara Branch,  
• Romanian Acoustical Society

Web: <http://www.mec.upt.ro/meca/avms/main.php>

- The conference focused on a broad range of topics related to acoustics and vibration, such as noise and vibration control, noise and vibration generation and propagation, effects of noise and vibration, condition monitoring and vibration testing, modelling, prediction and simulation of noise and vibration, environmental and occupational noise and vibration, noise and vibration attenuators, biomechanics and bioacoustics.
- The conference also discusses analytical, numerical and experimental techniques applicable to analyze linear and non-linear noise and vibration problems (including strong nonlinearity) and it is primarily intended to emphasize the actual trends and state-of-the-art developments in the above-mentioned topics. The primary audience of this conference consist of academics, researchers and professionals, as well as PhD students concerned with various fields of acoustics and vibration of mechanical structures.

### Publication of papers:

- Springer Proceedings in Physics, ISSN 0930-8989  
<https://link.springer.com/book/9783031480867>



## 9<sup>th</sup> IAHR Meeting of the WorkGroup on Cavitation and Dynamic Problems in Hydraulic Machinery and Systems (IAHRWG2023)

October 10-12, 2023, UPT Conference Center, Timisoara, Romania

**Organizers:** • Politehnica University Timisoara and  
• Romanian Academy – Timisoara Branch

Web: <https://www.iahrwg2023.upt.ro/>

• The IAHRWG2023 was focused on top technologies that address the current and future challenges facing the hydraulic turbines and hydropower equipment.

In particular, the 48 scientific presentations were focused on two main topics: • Cavitation in hydraulic machines and  
• Dynamic phenomena in hydropower systems.

The IAHRWG2023 brought together researchers from academia and industry:

- Canada (6),
- Czech Republic (7),
- France (1),
- Germany (7),
- Norway (2),
- Slovenia (1),
- Sweden (5),
- Switzerland (11),
- Romania (16).

### Publication of papers:

The manuscripts submitted to IAHRWG2023, presented and discussed during the conference, are submitted to the final review process and will be published open access as a volume in Institute of Physics Conference Series: Earth and Environmental Science:

<https://publishingsupport.iopscience.iop.org/ees-forthcoming-volumes/>



## 27<sup>th</sup> International Conference on System Theory, Control and Computing (ICSTCC 2023)

Conference Date: October 11 – 13, 2023, Timisoara, Romania

**Organizers:** • Department of Automation and Applied Informatics and Department of Computers and Information Technology of Politehnica University Timisoara; • Faculty of Automation, Computers and Electronics of University of Craiova; • Faculty of Automation and Computer Science of Technical University of Cluj-Napoca; • Faculty of Automatic Control and Computer Engineering of “Gheorghe Asachi” Technical University of Iasi; • Faculty of Control Systems, Computers, Electrical and Electronics Engineering of “Dunarea de Jos” University of Galati

Web: <http://icstcc2023.cs.upt.ro/>

ICSTCC 2023 has featured several kinds of presentations, including invited talks, contributed papers and special sessions. The outcome of ICSTCC 2023 has been a better understanding of some leading research areas, as already **System Theory, Control and Computing** have demonstrated. ICSTCC 2023 has welcomed papers on the following topics:

- **Automation and Robotics** (Linear and Nonlinear Control System Design, System Identification and Process Modeling, Robust and Adaptive Control, Robotics and Intelligent Control, Applications and Case Studies in Automation and Robotics, Embedded Systems);
- **Computer Science and Engineering** (Distributed Systems and Software Engineering, Databases, Systems of Programs and Expert Systems, Web Services, Internet Security, Software Tools and Methods, Grid Computing, Artificial Intelligence, Computer Architectures);
- **Electronics and Instrumentation** (Modelling, Simulation and CAD Tools, Signal Processing and Communication Systems, Linear and Nonlinear Circuits and Systems, Evolutionary Electronics)

### Publication of papers:

- The proceedings, which include the papers presented at ICSTCC 2023, will be submitted to **IEEE Xplore Digital Library**.



## 17<sup>th</sup> International Symposium in Management - Reinventing Management in Turbulent Times

20-21 October 2023, Timisoara & Silagiu, Romania, organized as an in-person conference

### Organizers:

- Politehnica University Timisoara and
- West University of Timisoara

Web: <https://www.sim2023.eu/>

The conference brought together academics, professionals, and students in order to discuss the challenges that management had to deal with during the economic crisis and with which it has been dealing with ever since.

Conference main topics:

- Management of innovation, • Business process management, entrepreneurship and innovation,
- Financial management and financial governance, • Strategic management, change management,
- Supply chain and operations management, • Sustainable management,
- The economics of small and medium-sized enterprises, • Third sector organisations management

### Publication of papers:

The accepted papers will be published in:

#### 1) EASTERN EUROPEAN ECONOMICS

• Special Issue: SMEs performance in Eastern European countries: access to finance, innovation and trade, ISSN 0012-8775, Web of Science - IF 1.365

2) Special Issue of **ACTA TECHNICA NAPOCENSIS SERIES-APPLIED MATHEMATICS, MECHANICS AND ENGINEERING Journal**, ISSN 1221-5872, emergent ISI Thomson/Clarivate Analytics journal), <https://atna-mam.utcluj.ro/index.php/Acta>

3) Special Issue of **HUMAN SYSTEMS MANAGEMENT journal** (ISSN 0167-2533 (P) / ISSN 1875-8703 (E), Web of Science: Emerging Sources Citation Index)

Template requirements are available here: <https://www.iospress.nl/journal/human-systems-management/>

## COHESION

### COHESION

2.11.2023-3.11.2023, ARChA, Timisoara, Romania

**Organizers:** Faculty of Architecture and Urban Planning, Politehnica University Timisoara

Web: <https://www.cohesion.ro/>

**COHESION 2023** focused on the formal and informal educational process in Architecture faculties, its current trends, and response to contemporary challenges. The conference therefore offered an important platform for architects, engineers, researchers, and other specialists to exchange and share their teaching and learning experience in architecture faculties on topics related to architecture, urban planning, heritage management and interior design. The 2023 edition was part of the Romanian Schools of Architecture Festival (FAST), an initiative of The Romanian Order of Architects, through its Education and Continuous Learning Department alongside architecture related Talks with internationally renowned guests, several exhibitions, guest lectures, and student workshops, all focusing on the cohesion around common values and visions for the profession.

**COHESION 2023** has welcomed papers on the following topics: • Contemporary approaches in architectural education; • Experimental / Innovative teaching methods; • Cohesion between professions / Overcoming disciplinary boundaries; • Architectural education and architectural practice; • Global challenges and architectural education; • Evaluation theories and methodologies; • Links between research and architectural education; • Inter-, Multi-, and Transdisciplinary education; • Curriculum design and development; • Management of Architectural Schools.

#### Publication of papers:

Articles presented in COHESION 2023 have been published online in the **Journal of Architecture, Urbanism and Heritage**, a peer-review academic journal which publishes research papers and advances theory, research, and practice in the fields of architecture and urban planning (<http://www.jauh.ro>)



### The 26<sup>th</sup> International Conference on Hydraulics and Pneumatics - HERVEX 2023

8-10 November, 2023, Baile Govora, Valcea County, Romania, physical participation

**Organizers:** • Hydraulics and Pneumatics Research Institute, Bucharest, Romania [INOE 2000-IHP], • Valcea Chamber of Commerce and Industry, Romania [CCIVL], • Wroclaw University of Science and Technology, Poland [WUST], • KOMAG Institute of Mining Technology, Poland [KOMAG], • Technical University of Moldova in Chisinau, Republic of Moldova [UTM], • National Institute of Research and Development for Machines and Installations Designed to Agriculture and Food Industry, • INMA Bucharest, Romania [INMA], • Politehnica University of Bucharest, Romania [UPB], • Politehnica University Timisoara, Romania [UPT], • Technical University of Cluj-Napoca, Romania [UTCN] and • "Dunarea de Jos" University of Galati, Romania [UDJG]

Web: <https://hervex.ro/links/>

#### Conference main topics:

- Modern hydraulic drives;
- Systems and equipment for mobile hydraulics
- Systems and equipment for industrial hydraulics
- Maintenance in fluid power
- Lubrication and tribology
- Environment and renewable energy
- Education and training in fluid power and renewable energy

#### Publication of papers:

Proceedings of International Conference on **HYDRAULICS, PNEUMATICS, SEALING ELEMENTS, TOOLS, PRECISION MECHANICS, SPECIFIC ELECTRONIC EQUIPMENT AND MECHATRONICS -HERVEX 2023** ISSN 1454 – 8003, November 8-10, Băile Govora, Romania

(<https://fluidas.ro/hervex/proceedings/proceedings2023.pdf>)



## The 14<sup>th</sup> International Conference “Innovative Technologies for Joining Advanced Materials” TIMA23

9.11.2023–10.11.2023, Library of Politehnica University, Timisoara, face-to-face and online

**Organizers:** • National R&D Institute for Welding and Material Testing- ISIM Timisoara;  
• Politehnica University Timișoara; • Technical Sciences Academy of Romania

Web: <https://www.isim.ro/tima/index.php>

### Conference main topics:

• New joining technologies, • Modelling and simulation of welding processes, • Specific problems in advanced materials joining, • Characterization of advanced materials and joints, • Fracture mechanics, damage of advanced materials and remaining life assessment, • Quality of welded joints and welded structures, • Engineering applications of surface coatings, • Non-Destructive Testing (NDT), • Nanoscience, nanotechnology and composites

### Publication of papers:

Papers are published in conference proceedings and will be indexed in the major international databases: ISI or SCOPUS, Ei Compendex, RAEXYS

The conference proceedings will be published in the **Trans Tech Publications' periodicals 'Journal of Nano Research – JNanoR' / Nano Hybrids and Composites - NHC** (printed and online), and/or **'Key Engineering Materials' / Materials Science Forum/Solid State Phenomena/Defect and Diffusion Forum\*(online)**, selected materials science related papers only, with Indexing and DOI.

The periodical will be available in full text online at <https://www.scientific.net/JNanoR>, or <https://www.scientific.net/NHC>, or [www.scientific.net/KEM](http://www.scientific.net/KEM) or <https://www.scientific.net/MSF/Details> or <https://www.scientific.net/SSP/Details> or <https://www.scientific.net/DDF/Details>. All accepted abstracts for the 14<sup>th</sup> International Conference on Innovative Technologies for Joining Advanced Materials – TIMA23 will be published in a special issue of the journal **Welding & Material Testing**, ISSN 1453-0392, available online on the web page [www.bid-isim.ro](http://www.bid-isim.ro).

\*Abstracted/Indexing in ESCI (Web of Science, Thomson Reuters) <http://ip-science.thomsonreuters.com/mjl/>.



## The XIII International Conference “INDUSTRIAL ENGINEERING AND ENVIRONMENTAL PROTECTION” (IIZS2023), October 5 – 6, 2023, Zrenjanin, Serbia

**Organizers:** • University of Novi Sad, Technical Faculty “Mihajlo Pupin”, Zrenjanin, SERBIA, in cooperation with partners: • University Politehnica Timisoara, Faculty of Engineering, Hunedoara, ROMANIA, University “St. Kliment Ohridski”, • Technical Faculty, Bitola, MACEDONIA, “Aurel Vlaicu” University of Arad, • Faculty of Engineering, Arad ROMANIA, • University of East Sarajevo, Faculty of Mechanical Engineering East Sarajevo, BOSNIA & HERZEGOVINA and University of Giresun, • Faculty of Engineering, Giresun, TURKEY

Web: <http://www.tfzr.uns.ac.rs/iizs/>

The main goals of the conference are: innovation and expansion of knowledge engineers in industry and environmental protection; support to researchers in presenting the actual results of research projects, establishing new contacts with leading national and international institutions and universities; popularization of the faculty and its leading role in our society and the immediate environment, in order to attract quality young population for studying at our faculty, cooperation with other organizations, public companies and industry; initiative for collecting ideas in solving specific practical problems; interconnection and business contacts; introducing professional and business organizations with results of scientific and technical research; presentation of scientific knowledge and exchange of experiences in the field of Industrial Engineering.

Framework topics: • INDUSTRIAL ENGINEERING: • Mechanical Engineering, • Energetics and process technique, • Designing and maintenance, • Oil and gas engineering

• ENVIRONMENTAL ENGINEERING: • Health and environmental protection, • Environmental Management, • Occupational Safety

### Publication of papers:

• Proceedings of INTERNATIONAL CONFERENCE INDUSTRIAL ENGINEERING AND ENVIRONMENTAL PROTECTION (12; 2023; Zrenjanin), ISBN 978–86–7672–360–7, published by University of Novi Sad, Technical Faculty “Mihajlo Pupin”, Zrenjanin, SERBIA

(<http://www.tfzr.uns.ac.rs/iizs/files/IIZS%202021%20Proceedings.pdf>)

• Selected papers in **ANNALS of Faculty Engineering Hunedoara – International Journal of Engineering**, ISSN: 1584–2665, ISSN: 2601–2332, ISSN–L: 1584–2665, published by Politehnica University Timisoara, Faculty of Engineering, Hunedoara, ROMANIA, <http://annals.fih.upt.ro/>

• Selected papers in **ACTA TECHNICA CORVINIENSIS – Bulletin of Engineering**, e-ISSN: 2067–3809, published by Politehnica University Timisoara, Faculty of Engineering, Hunedoara, ROMANIA, <http://acta.fih.upt.ro/>

## Technical Translation Today

### Technical Translation Today

16.11.2023–17.11.2023, Politehnica University Timișoara

#### Organizers:

- Politehnica Center for Advanced Translation Studies – PoliCAT, Politehnica University Timisoara
- The Directorate-General for Translation of the European Commission

Web: <https://tewtm2023.webnode.ro/home2/>

- LSP translation is part of all undergraduate programs in translation studies.
- Technical translation, in particular, is a core discipline which plays an important part in preparing students for a very demanding and challenging translation market.
- Its importance was highlighted in scholarly articles, according to which some 90% of the translations on the global market are technical translations.
- The international conference organized in Timisoara, part of the **Translating Europe Workshop series** of the Directorate General for Translation of the European Commission, will focus on key topics related to technical translation, including but not limited to skills, quality assessment, technology, terminology, and the image of the technical translator today.

#### Publication of papers:

- Scientific Bulletin of Politehnica University Timisoara, Transactions on Modern Languages



### 2<sup>nd</sup> International Conference: Advances in 3OM: Opto-Mechatronics, Opto-Mechanics and Optical Metrology

11–14 December 2023, Conference Center of the Politehnica University Timisoara Library, Timisoara

#### Organizers:

- Politehnica University Timisoara, 3OM Optomechatronics Group

Web: <https://3om-group-optomechatronics.ro/advances-in-3om-conference-2023/>

The 3OM concept unites three complementary domains:

(1) **Opto-Mechatronics** is a blend of Optics & Photonics, Precision Mechanics, Electronics, Control & Automation, as well as IT.

(2) **Opto-Mechanics** usually fills the gap between the high requirements of Optical Design and the capabilities of Mechanical technologies, addressing tolerances, errors, positioning issues, and methods to tackle them. Kinematic and dynamic aspects of optical systems with moving parts are also approached, and this leads back to Control & Automation, but also to material issues, involving for example Finite Element Analysis (FEA).

(3) **Optical Metrology** is a large umbrella of applications which benefits from both domains above and includes fields as diverse as industrial measurements (such as Non Destructive Testing (NDT)), biomedical imaging (with a range of techniques, for example Optical Coherence Tomography (OCT) or Photo-acoustics), Remote Sensing, as well as Security & Defense. Other fields that apply 3OM are also within the topics of the Conference, including but not limited to Laser Manufacturing and Robotics, as well as Lasers in Medicine, Laser Scanners, Optical Devices, Optical Design, Applied Physics.

#### Publication of papers:

Accepted and presented contributions can be submitted for publication in **Proceedings of SPIE** (indexed in ISI Web of Science).

Papers recommended by the Scientific Committee can be submitted for publication in (and they will undergo the regular peer-review process of) Special Issues of several high-impact journals, including **Sensors SI**, **Applied Sciences SI 1**, **Applied Sciences SI 2**, **Medicina SI**, and **Materials SI**.



# SCIENTIFIC JOURNALS







## Transactions on Modern Languages Volume 22, Issue 1, 2023

[www.sc.upt.ro/ro/publicatii/buletinul-stiintific/about](http://www.sc.upt.ro/ro/publicatii/buletinul-stiintific/about)

- The Transactions on Modern languages, published by the Department of Communication and Foreign Languages, has its origin in The Social Science and Humanities Series, started in 1991 under ISSN 1223-1959.
- The Transactions of Modern Languages publishes original papers in all areas of theoretical and applied linguistics: Linguistics, Translation and Interpreting Studies, Discourse Analysis, Pragmatics, Rhetoric, Terminology, LSP, Foreign Language Teaching.
- The journal is included in the CEEOL, Fabula and EBSCO data bases.
- ISSN 1583-7467, ISSN-L 1583-7467



## Transactions on Hydrotechnics Volume 68 (82), Issue 1, 2023

<http://www.ct.upt.ro/buletinhidro/index.htm>

- The Scientific Bulletin of the Politehnica University Timișoara, Transactions on Hydrotechnics is coordinated since 1992 by the Faculty of Hydrotechnical Engineering. Published papers in the journal focus on engineering sciences, civil engineering, theoretical and applied hydraulic, mathematics and numerical modeling, hydrology and water management, hydrotechnical developments and constructions, land improvement (irrigations, drainage, erosion control), engineering and sustainable rural development, water supply and sewerage systems, wastewater treatment, hydraulic structures and technologies.
- The Journal is published entirely in English, with abstracts and keywords, with international exposure.
- "The revue is known for experts from home and abroad, is accredited and ranked in the "B+" CATEGORY Journal by CNCIS, and is indexed by EBSCO Publishing."
- ISSN 1224-6042, ISSN-L 1224-6042



ACTA TECHNICA CORVINIENSIS – Bulletin of Engineering  
<http://acta.fih.upt.ro/>

Volume XVI (Tome XVI), Year 2023

Issue 1 (Fascicule 1: January-March), Issue 2 (Fascicule 2: April-June), Issue 3 (Fascicule 3: July-September), Issue 4 (Fascicule 4: October-December)

- ACTA TECHNICA CORVINIENSIS – Bulletin of Engineering is an independent, free-access, online, international and multidisciplinary scientific publication edited by the Politehnica University Timișoara, Faculty Engineering Hunedoara and Faculty of Mechanical Engineering Timișoara.
- The Journal is focused on engineering sciences and other innovative allied research areas, in all fields of science and technology based on its originality, importance and timeliness.
- ACTA TECHNICA CORVINIENSIS – Bulletin of Engineering is accredited and ranked in the “B+” CATEGORY Journal by The National University Research Council’s Classification of Romanian Journals (CNCSIS), and is indexed by Index Copernicus, Google Scholar, EBSCO Publishing, DOAJ, SCIRUS, EVISA, ProQuest, DRJI, CAS, BASE, ULRICHsweb – Global serials directory, Directory Indexing of International Research Journals, Electronic Journals Library etc.



ANNALS of Faculty Engineering Hunedoara –  
 International Journal of Engineering

<http://annals.fih.upt.ro/>

Volume XXI (Tome XXI), Year 2023

Issue 1 (Fascicule 1: February), Issue 2 (Fascicule 2: May), Issue 3 (Fascicule 3: August), Issue 4 (Fascicule 4: November)

- ANNALS of Faculty Engineering Hunedoara – International Journal of Engineering is a multi-disciplinary journal, which covers all aspects of scientific, engineering and technical disciplines including applications of scientific inventions for engineering, technological and industrial purposes, advances in engineering, technology and science.
- ANNALS of Faculty Engineering Hunedoara – International Journal of Engineering is accredited and ranked in the “B+” category by The National University Research Council’s Classification of Romanian Journals (CNCSIS), and is indexed by Index Copernicus, Google Scholar, EBSCO Publishing, DOAJ, SCIRUS, EVISA, ProQuest, DRJI, CAS, BASE, ULRICHsweb – Global serials directory, Directory Indexing of International Research Journals, Electronic Journals Library etc.



**Nonconventional Technologies Review**  
Volume XXVII, Issue 1, Issue 2, Issue 3, Issue 4, 2023

[www.revtn.ro](http://www.revtn.ro)

- The Nonconventional Technologies Review is a scientific engineering publication of the Romanian Association for Nonconventional Technologies (ARTN), which has started in 1997, with quarterly appearances. The publication is addressed to all engineers and scientists interested in nonconventional technologies.
- Nonconventional Technologies Review is indexed in ProQuest, EBSCOhost, DOAJ, Google Scholar and Index Copernicus, and is classified as B+ according to the Romanian journal system.
- ISSN codes are:  
Print ISSN: 2359-8646; ISSN-L: 2359-8646  
On-line ISSN: 2359-8654



**Academic Journal of Manufacturing Engineering**  
Volume 21, Issue 1, Issue 2, Issue 3, Issue 4, 2023

<https://www.ajme.ro>

- The Academic Journal of Manufacturing Engineering intends to provide the specialists in the manufacturing engineering field a possibility for sharing and exchanging results and information by publishing the results of their work.
- Academic Journal of Manufacturing Engineering is recognized as a B+ journal by the Romanian National Council of Scientific Research and indexed by Index Copernicus international database.
- ISSN: 1583-7904, Online ISSN: 2601-3045



## Journal of Architecture, Urbanism and Heritage Volume 6, Issue 2, 2023

[www.jauh.ro/](http://www.jauh.ro/)

- The JOURNAL OF ARCHITECTURE, URBANISM AND HERITAGE, JAUH, is a peer-review academic journal which publishes original research papers and advances theory, research and practice in the fields of architecture and urban planning.
- The interdisciplinary scholarly publication is aimed at advancing conceptual, scientific, and applied understandings of Architecture, Interior design, Urbanism, Built environment and Preservation and heritage studies.
- Its articles include recent research findings, empirical research papers, theoretical and integrative review articles, book reviews and innovative new practices, creating a link between theory and practice, researchers and practicing professionals.

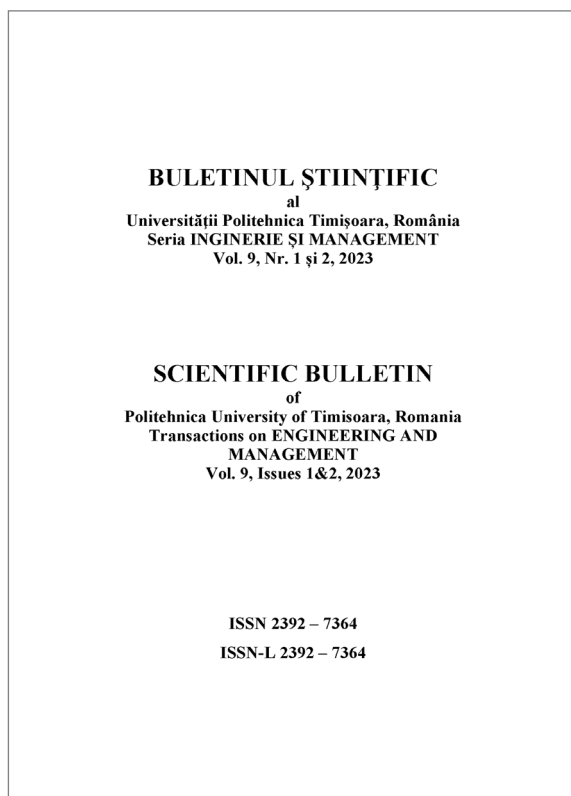

## Transactions on Engineering and Management Volume 9, Issue 1, Issue 2, 2023

[www.mpt.upt.ro/cercetare/buletin-stiintific.html](http://www.mpt.upt.ro/cercetare/buletin-stiintific.html)

- The Scientific Bulletin of Politehnica University Timișoara, Transaction on Engineering and Management presents research results in the field of industrial management and business studies that are of significant impact on major contemporary issues.
- The journal welcomes submissions of theoretical, methodological, empirical, policy-oriented, as well as industrial papers in all the field. Additionally, it considers contributions that combine engineering and management studies with any other field of inquiry.
- SCIENTIFIC BULLETIN of Politehnica University Timișoara, Transactions on ENGINEERING AND MANAGEMENT is indexed: Index Copernicus, Google Scholar (under review), Ulrich (under review).

# ISI PAPERS IN HIGHLIGHT



## Web of Science - Clarivate Analytics Hot Papers

A paper published in the past two years that received a number of citations in the most recent two-month period that places it in the top 0.1% of papers in the same field.

Zamfirache, I.A., Precup, R.E., Roman, R.C., Petriu, E.M. Policy Iteration Reinforcement Learning-based control using a Grey Wolf Optimizer algorithm, INFORMATION SCIENCES, Volume: 585, Pages: 162-175, ISSN: 0020-0255, eISSN: 1872-6291, 2021;  
Times Cited in Web of Science Core Collection: 124



Pozna, C., Precup, R.E., Horvath, E., Petriu, E.M. Hybrid Particle Filter-Particle Swarm Optimization Algorithm and Application to Fuzzy Controlled Servo Systems, IEEE TRANSACTIONS ON FUZZY SYSTEMS, Volume: 30, Issue: 10, Pages: 4286-4297, ISSN: 1063-6706, eISSN: 1941-0034, 2022;  
Times Cited in Web of Science Core Collection: 112



Yu, S.B., Abbas, J., Draghici, A., Negulescu, O.H., Ain, N.U. Social Media Application as a New Paradigm for Business Communication: The Role of COVID-19 Knowledge, Social Distancing, and Preventive Attitudes, FRONTIERS IN PSYCHOLOGY, Volume: 13, Article Number: 903082, PubMed ID: 35664180, ISSN: 1664-1078, 2022;  
Times Cited in Web of Science Core Collection: 104



Zamfirache, I.A., Precup, R.E., Roman, R.C., Petriu, E.M. Reinforcement Learning-based control using Q-learning and gravitational search algorithm with experimental validation on a nonlinear servo system, INFORMATION SCIENCES, Volume: 583, Pages: 99-120, ISSN: 0020-0255, eISSN: 1872-6291, 2021;  
Times Cited in Web of Science Core Collection: 101



Hot papers are papers that receive a large number of citations soon after publication, relative to other papers of the same field and age. They are papers published in the past two years that received a number of citations in the most recent two-month period that places them in the top 0.1% of papers in the same field.

\* The data was obtained from Web of Science - Clarivate Analytics in 4 April 2024

## Web of Science - Clarivate Analytics Hot Paper

This hot paper was published in the past two years and received enough citations in January/April 2023 to place it in the top 0.1% of papers in the academic field of **Computer Science**.

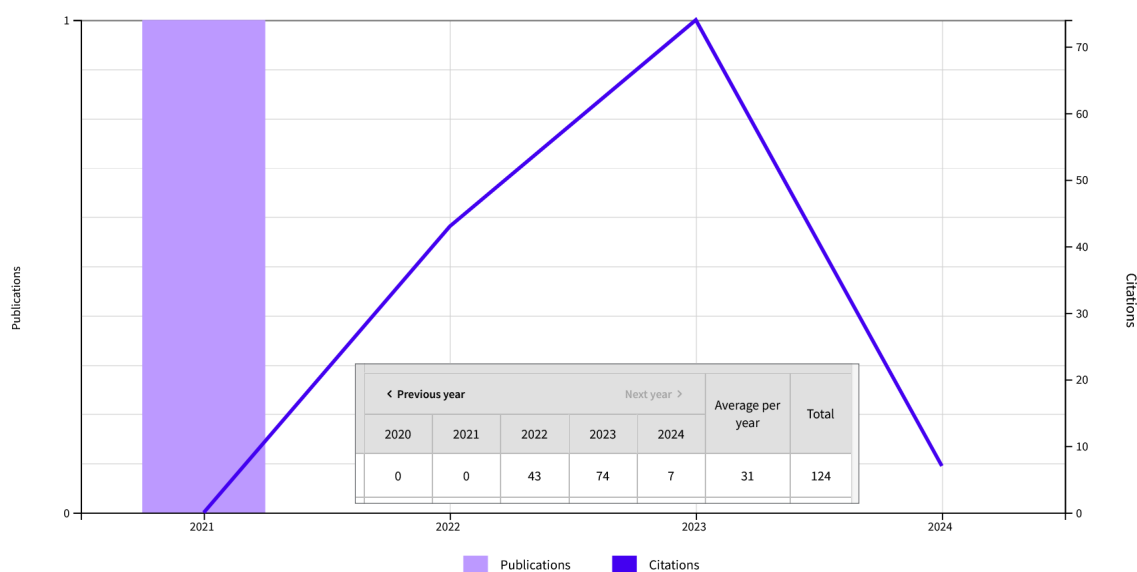

Zamfirache, I.A., Precup, R.E., Roman, R.C., Petriu, E.M. Policy Iteration Reinforcement Learning-based control using a Grey Wolf Optimizer algorithm, INFORMATION SCIENCES, Volume: 585, Pages: 162-175, ISSN: 0020-0255, eISSN: 1872-6291, 2021; Times Cited in Web of Science Core Collection: 124

**Abstract:** This paper presents a new Reinforcement Learning (RL)-based control approach that uses the Policy Iteration (PI) and a metaheuristic Grey Wolf Optimizer (GWO) algorithm to train the Neural Networks (NNs). Due to an efficient tradeoff to exploration and exploitation, the GWO algorithm shows good results in NN training and solving complex optimization problems. The proposed approach is compared to the classical PI RL-based control approach using the Gradient Descent (GD) algorithm, and with the RL-based control approach which uses the metaheuristic Particle Swarm Optimization (PSO) algorithm. The experiments are conducted using a nonlinear servo system laboratory equipment. Each approach evaluated on

how well it solves the optimal reference tracking control for an experimental servo system position control system. The policy NNs specific to all three approaches are implemented as state feedback with integrator controllers to remove the steady-state control errors and thus ensure the convergence of the objective function. Because of the random nature of metaheuristic algorithms, the experiments for GWO and PSO algorithms are run multiple times and the results are averaged before the conclusions are presented. The experimental results shows that for the control objective considered in this paper, the GWO algorithm represents a better solution compared to GD and PSO algorithms.



## Web of Science - Clarivate Analytics Hot Paper

This hot paper was published in the past two years and received enough citations in January/June 2023 to place it in the top 0.1% of papers in the academic field of **Engineering**.

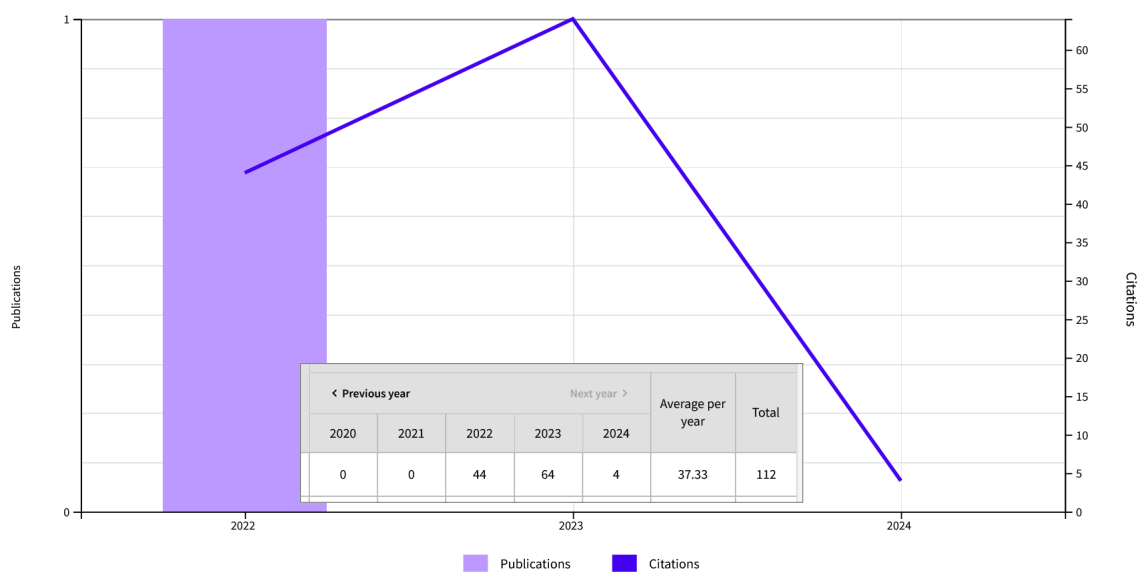

Pozna, C., Precup, R.E., Horvath, E., Petriu, E.M. Hybrid Particle Filter-Particle Swarm Optimization Algorithm and Application to Fuzzy Controlled Servo Systems, IEEE TRANSACTIONS ON FUZZY SYSTEMS, Volume: 30, Issue: 10, Pages: 4286-4297, ISSN: 1063-6706, eISSN: 1941-0034, 2022; Times Cited in Web of Science Core Collection: 112

**Abstract:** This article presents a hybrid metaheuristic optimization algorithm that combines particle filter (PF) and particle swarm optimization (PSO) algorithms. The new PF-PSO algorithm consists of two steps: the first generates randomly the particle population; and the second zooms the search domain. An application of this algorithm to the optimal tuning of proportional-integral-fuzzy controllers

for the position control of a family of integral-type servo systems is then presented as a second contribution. The reduction in PF-PSO algorithm's cost function allows for reduced energy consumption of the fuzzy control system. A comparison with other metaheuristic algorithms on canonical test functions and experimental results are presented at the end of this article.

## Web of Science - Clarivate Analytics Hot Paper

This hot paper was published in the past two years and received enough citations in January/April and September/December 2023 to place it in the top 0.1% of papers in the academic field of **Psychiatry/Psychology**.

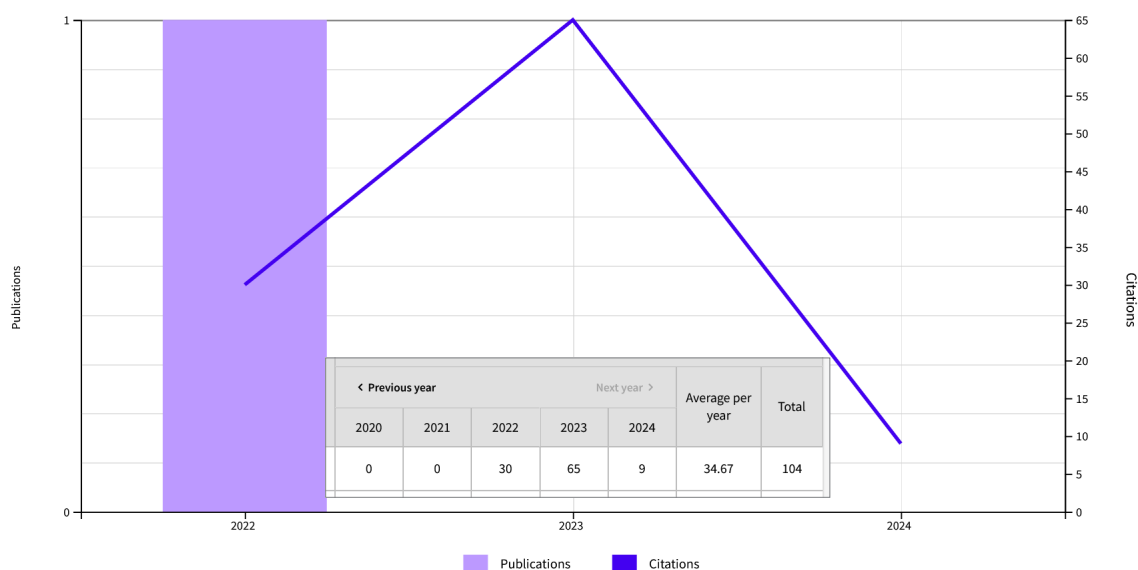

Yu, S.B., Abbas, J., Draghici, A., Negulescu, O.H., Ain, N.U. Social Media Application as a New Paradigm for Business Communication: The Role of COVID-19 Knowledge, Social Distancing, and Preventive Attitudes, *FRONTIERS IN PSYCHOLOGY*, Volume: 13, Article Number: 903082, PubMed ID: 35664180, ISSN: 1664-1078, 2022;  
Times Cited in Web of Science Core Collection: 104

**Abstract:** Business firms and the public have encountered massive consequences of the COVID-19 pandemic. This pandemic has become the most significant challenge and influenced all communities. This research study focuses on exploring the relationship between COVID-19 knowledge, social distancing, individuals' attitudes toward social media use, and practices of using social media amid the COVID-19 crisis. This study examines how attitudes toward social media use mediate the linkage between COVID-19 knowledge, social distancing, and practices for social media use. This survey uses a non-probability convenience sampling approach to collect samples and recruit willing respondents with their consent for data collection. This study recorded the feedback from 348 participants who encountered the indirect/direct effects of nationwide lockdowns, restrictions on social gatherings, and COVID-19 infection. The findings validate the

proposed hypotheses for their direct effects and indicate significant beta-values, t-statistics, and the p-values at  $p < 0.001$ . The results validate a relationship between the COVID-19 knowledge of and social distancing practices. Similarly, the results approved a positive link between social distancing and attitudes toward social media use amid COVID-19. The findings validate the relation between social distancing and attitudes toward social media use during COVID-19 challenges (beta-value = 0.22 and t-statistics = 3.078). The results show the linkage between attitudes toward social media use and practices of using social media (beta-value = 0.41, and t-statistics = 7.175). Individuals' attitude toward social media use during COVID-19 mediates the connection between COVID-19 knowledge and COVID-19 practices of using social media use. The results validate the first mediation at beta-value = 0.21 and t-statistic = 5.327.

## Web of Science - Clarivate Analytics Hot Paper

This hot paper was published in the past two years and received enough citations in January/April 2023 to place it in the top 0.1% of papers in the academic field of **Computer Science**.

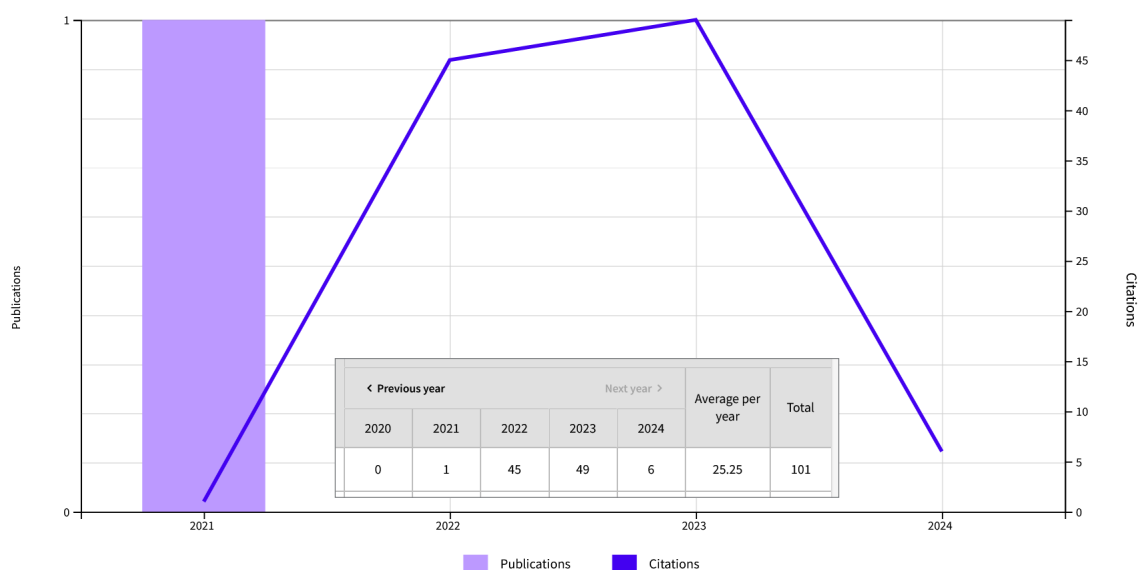

Zamfirache, I.A., Precup, R.E., Roman, R.C., Petriu, E.M. Reinforcement Learning-based control using Q-learning and gravitational search algorithm with experimental validation on a nonlinear servo system, INFORMATION SCIENCES, Volume: 583, Pages: 99-120, ISSN: 0020-0255, eISSN: 1872-6291, 2021;  
Times Cited in Web of Science Core Collection: 101

**Abstract:** This paper presents a novel Reinforcement Learning (RL)-based control approach that uses a combination of a Deep Q-Learning (DQL) algorithm and a metaheuristic Gravitational Search Algorithm (GSA). The GSA is employed to initialize the weights and the biases of the Neural Network (NN) involved in DQL in order to avoid the instability, which is the main drawback of the traditional randomly initialized NNs. The quality of a particular set of weights and biases is measured at each iteration of the GSA-based initialization using a fitness function aiming to achieve the predefined optimal control or learning objective. The data generated during the RL process is used in training a NN-based controller that will be able to autonomously achieve the optimal reference tracking control objective. The proposed

approach is compared with other similar techniques which use different algorithms in the initialization step, namely the traditional random algorithm, the Grey Wolf Optimizer algorithm, and the Particle Swarm Optimization algorithm. The NN-based controllers based on each of these techniques are compared using performance indices specific to optimal control as settling time, rise time, peak time, overshoot, and minimum cost function value. Real-time experiments are conducted in order to validate and test the proposed new approach in the framework of the optimal reference tracking control of a nonlinear position servo system. The experimental results show the superiority of this approach versus the other three competing approaches.



## Web of Science - Clarivate Analytics Highly Cited Papers

Selected from the most recent 10 years of data, Highly Cited Papers reflect the top 1% of papers by field and publication year. Highly Cited Papers help identify breakthrough research within a research field and are used within Web of Science to identify and refine the most influential research papers.

Rajak, D.K., Pagar, D.D., Menezes, P.L., Linul, E. Fiber-Reinforced Polymer Composites: Manufacturing, Properties, and Applications, POLYMERS, Volume: 11, Issue: 10, Article Number: 1667, PubMed ID: 31614875, eISSN: 2073-4360, 2019;  
Times Cited in Web of Science Core Collection: 628

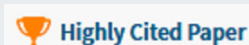

Sarbu, I., Sebarchievici, C. A Comprehensive Review of Thermal Energy Storage, SUSTAINABILITY, Volume: 10, Issue: 1, Article Number: 191, ISSN: 2071-1050, 2018;  
Times Cited in Web of Science Core Collection: 566



Boldea, I., Tutelea, L.N., Parsa, L., Dorrell, D. Automotive Electric Propulsion Systems With Reduced or No Permanent Magnets: An Overview, IEEE TRANSACTIONS ON INDUSTRIAL ELECTRONICS, Volume: 61, Issue: 10, Pages: 5696-5711, ISSN: 0278-0046, eISSN: 1557-9948, 2014;  
Times Cited in Web of Science Core Collection: 549



Ancuti, C.O., Ancuti, C., De Vleeschouwer, C., Bekaert, P. Color Balance and Fusion for Underwater Image Enhancement, IEEE TRANSACTIONS ON IMAGE PROCESSING, Volume: 27, Issue: 1, Pages: 379-393, PubMed ID: 28981416, ISSN: 1057-7149, eISSN: 1941-0042, 2018;  
Times Cited in Web of Science Core Collection: 546



Sarbu, I., Sebarchievici, C. General review of ground-source heat pump systems for heating and cooling of buildings, ENERGY AND BUILDINGS, Volume: 70, Pages: 441-454, ISSN: 0378-7788, eISSN: 1872-6178, 2014;  
Times Cited in Web of Science Core Collection: 411

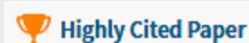

Albulescu, C.T. COVID-19 and the United States financial markets' volatility, FINANCE RESEARCH LETTERS, Volume: 38, Article Number: 101699, PubMed ID: 32837380, ISSN: 1544-6123, eISSN: 1544-6131, 2021;  
Times Cited in Web of Science Core Collection: 282



Covaci, C., Gontean, A. Piezoelectric Energy Harvesting Solutions: A Review, SENSORS, Volume: 20, Issue: 12, Article Number: 3512, PubMed ID: 32575888, eISSN: 1424-8220, 2020;  
Times Cited in Web of Science Core Collection: 252



Highly Cited Papers received enough citations as of January/December 2023 to place them in the top 1% of their academic fields based on a highly cited threshold for the field and publication year.

\* The data was obtained from Web of Science - Clarivate Analytics in 4 April 2024

## Web of Science - Clarivate Analytics Highly Cited Papers

Selected from the most recent 10 years of data, Highly Cited Papers reflect the top 1% of papers by field and publication year. Highly Cited Papers help identify breakthrough research within a research field and are used within Web of Science to identify and refine the most influential research papers.

Roman, R.C., Precup, R.E., Petriu, E.M. Hybrid data-driven fuzzy active disturbance rejection control for tower crane systems, EUROPEAN JOURNAL OF CONTROL, Volume: 58, Pages: 373-387, ISSN: 0947-3580, eISSN: 1435-5671, 2021;  
Times Cited in Web of Science Core Collection: 185

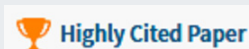

Sarbu, I., Dorca, A. Review on heat transfer analysis in thermal energy storage using latent heat storage systems and phase change materials, INTERNATIONAL JOURNAL OF ENERGY RESEARCH, Volume: 43, Issue: 1, Pages: 29-64, ISSN: 0363-907X, eISSN: 1099-114X, 2019;  
Times Cited in Web of Science Core Collection: 169

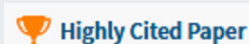

Gheju, M., Balcu, I., Mosoarca, G. Removal of Cr(VI) from aqueous solutions by adsorption on MnO<sub>2</sub>, JOURNAL OF HAZARDOUS MATERIALS, Volume: 310, Pages: 270-277, PubMed ID: 26947189, ISSN: 0304-3894, eISSN: 1873-3336, 2016;  
Times Cited in Web of Science Core Collection: 162

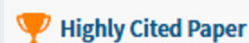

Ardean, C., Davidescu, C.M., Nemes, N.S., Negrea, A., Ciopec, M., Duteanu, N., Negrea, P., Duda-Seiman, D., Musta, V. Factors Influencing the Antibacterial Activity of Chitosan and Chitosan Modified by Functionalization, INTERNATIONAL JOURNAL OF MOLECULAR SCIENCES, Volume: 22, Issue: 14, Article Number: 7449, PubMed ID: 34299068, eISSN: 1422-0067, 2021;  
Times Cited in Web of Science Core Collection: 129



Precup, R.E., Teban, T.A., Albu, A., Borlea, A.B., Zamfirache, I.A., Petriu, E.M. Evolving Fuzzy Models for Prosthetic Hand Myoelectric-Based Control, IEEE TRANSACTIONS ON INSTRUMENTATION AND MEASUREMENT, Volume: 69, Issue: 7, Pages: 4625-4636, ISSN: 0018-9456, eISSN: 1557-9662, 2020;  
Times Cited in Web of Science Core Collection: 129



Zamfirache, I.A., Precup, R.E., Roman, R.C., Petriu, E.M. Policy Iteration Reinforcement Learning-based control using a Grey Wolf Optimizer algorithm, INFORMATION SCIENCES, Volume: 585, Pages: 162-175, ISSN: 0020-0255, eISSN: 1872-6291, 2021;  
Times Cited in Web of Science Core Collection: 124

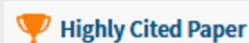

Highly Cited Papers received enough citations as of January/December 2023 to place them in the top 1% of their academic fields based on a highly cited threshold for the field and publication year.

\* The data was obtained from Web of Science - Clarivate Analytics in 4 April 2024

## Web of Science - Clarivate Analytics Highly Cited Papers

Selected from the most recent 10 years of data, Highly Cited Papers reflect the top 1% of papers by field and publication year. Highly Cited Papers help identify breakthrough research within a research field and are used within Web of Science to identify and refine the most influential research papers.

Tmusic, G., Manfreda, S., Aasen, H., James, M.R., Goncalves, G., Ben-Dor, E., Brook, A., Polinova, M., Arranz, J.J., Meszaros, J., Zhuang, R.D., Johansen, K., Malbeteau, Y., de Lima, I.P., Davids, C., Herban, S., McCabe, M.F. Current Practices in UAS-based Environmental Monitoring, REMOTE SENSING, Volume: 12, Issue: 6, Article Number: 1001, eISSN: 2072-4292, 2020;  
Times Cited in Web of Science Core Collection: 118

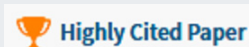

Pozna, C., Precup, R.E., Horvath, E., Petriu, E.M. Hybrid Particle Filter-Particle Swarm Optimization Algorithm and Application to Fuzzy Controlled Servo Systems, IEEE TRANSACTIONS ON FUZZY SYSTEMS, Volume: 30, Issue: 10, Pages: 4286-4297, ISSN: 1063-6706, eISSN: 1941-0034, 2022;  
Times Cited in Web of Science Core Collection: 112

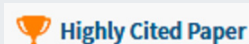

Borlea, I.D., Precup, R.E., Borlea, A.B., Iercan, D. A Unified Form of Fuzzy C-Means and K-Means algorithms and its Partitional Implementation, KNOWLEDGE-BASED SYSTEMS, Volume: 214, Article Number: 106731, ISSN: 0950-7051, eISSN: 1872-7409, 2021;  
Times Cited in Web of Science Core Collection: 105

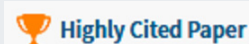

Yu, S.B., Abbas, J., Draghici, A., Negulescu, O.H., Ain, N.U. Social Media Application as a New Paradigm for Business Communication: The Role of COVID-19 Knowledge, Social Distancing, and Preventive Attitudes, FRONTIERS IN PSYCHOLOGY, Volume: 13, Article Number: 903082, PubMed ID: 35664180, ISSN: 1664-1078, 2022;  
Times Cited in Web of Science Core Collection: 104

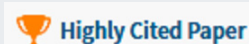

Zamfirache, I.A., Precup, R.E., Roman, R.C., Petriu, E.M. Reinforcement Learning-based control using Q-learning and gravitational search algorithm with experimental validation on a nonlinear servo system, INFORMATION SCIENCES, Volume: 583, Pages: 99-120, ISSN: 0020-0255, eISSN: 1872-6291, 2021;  
Times Cited in Web of Science Core Collection: 101



Zhou, Y.Y., Draghici, A., Abbas, J., Mubeen, R., Boatca, M.E., Salam, M.A. Social Media Efficacy in Crisis Management: Effectiveness of Non-pharmaceutical Interventions to Manage COVID-19 Challenges, FRONTIERS IN PSYCHIATRY, Volume: 12, Article Number: 626134, PubMed ID: 35197870, ISSN: 1664-0640, 2022;  
Times Cited in Web of Science Core Collection: 86

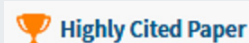

Highly Cited Papers received enough citations as of January/December 2023 to place them in the top 1% of their academic fields based on a highly cited threshold for the field and publication year.

\*The data was obtained from Web of Science - Clarivate Analytics in 4 April 2024

## Web of Science - Clarivate Analytics Highly Cited Papers

Selected from the most recent 10 years of data, Highly Cited Papers reflect the top 1% of papers by field and publication year. Highly Cited Papers help identify breakthrough research within a research field and are used within Web of Science to identify and refine the most influential research papers.

Precup, R.E., David, R.C., Roman, R.C., Szedlak-Stinean, A.I., Petriu, E.M. Optimal tuning of interval type-2 fuzzy controllers for nonlinear servo systems using Slime Mould Algorithm, INTERNATIONAL JOURNAL OF SYSTEMS SCIENCE, ISSN: 0020-7721, eISSN: 1464-5319, 2021;  
Times Cited in Web of Science Core Collection: 86

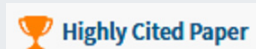

Precup, R.E., David, R.C., Roman, R.C., Petriu, E.M., Szedlak-Stinean, A.I. Slime Mould Algorithm-Based Tuning of Cost-Effective Fuzzy Controllers for Servo Systems, INTERNATIONAL JOURNAL OF COMPUTATIONAL INTELLIGENCE SYSTEMS, Volume: 14, Issue: 1, Pages: 1042-1052, ISSN: 1875-6891, eISSN: 1875-6883, 2021;  
Times Cited in Web of Science Core Collection: 86



Dar, A.A., Hameed, J., Huo, C.H., Sarfraz, M., Albasher, G., Wang, C.Y., Nawaz, A. Recent optimization and panelizing measures for green energy projects; insights into CO2 emission influencing to circular economy, FUEL, Volume: 314, Article Number: 123094, ISSN: 0016-2361, eISSN: 1873-7153, 2022;  
Times Cited in Web of Science Core Collection: 58



Mohsin, M., Jamil, K., Naseem, S., Sarfraz, M., Ivascu, L. Elongating Nexus Between Workplace Factors and Knowledge Hiding Behavior: Mediating Role of Job Anxiety, PSYCHOLOGY RESEARCH AND BEHAVIOR MANAGEMENT, Volume: 15, Pages: 441-457, PubMed ID: 35250318, ISSN: 1179-1578, 2022;  
Times Cited in Web of Science Core Collection: 41



Zamfirache, I.A., Precup, R.E., Roman, R.C., Petriu, E.M. Neural Network-based control using Actor-Critic Reinforcement Learning and Grey Wolf Optimizer with experimental servo system validation, EXPERT SYSTEMS WITH APPLICATIONS, Volume: 225, Article Number: 120112, ISSN: 0957-4174, eISSN: 1873-6793, 2023;  
Times Cited in Web of Science Core Collection: 29



Sarfraz, M., Khawaja, K.F., Ivascu, L. Factors affecting business school students' performance during the COVID-19 pandemic: A moderated and mediated model, INTERNATIONAL JOURNAL OF MANAGEMENT EDUCATION, Volume: 20, Issue: 2, Article Number: 100630, ISSN: 0020-0255, eISSN: 1872-6291, 2021;  
Times Cited in Web of Science Core Collection: 27



Highly Cited Papers received enough citations as of January/December 2023 to place them in the top 1% of their academic fields based on a highly cited threshold for the field and publication year.

\* The data was obtained from Web of Science - Clarivate Analytics in 4 April 2024



## Web of Science - Clarivate Analytics Highly Cited Paper

As of January/December 2023, this highly cited paper received enough citations to place it in the top 1% of the academic field of **Chemistry** based on a highly cited threshold for the field and publication year.

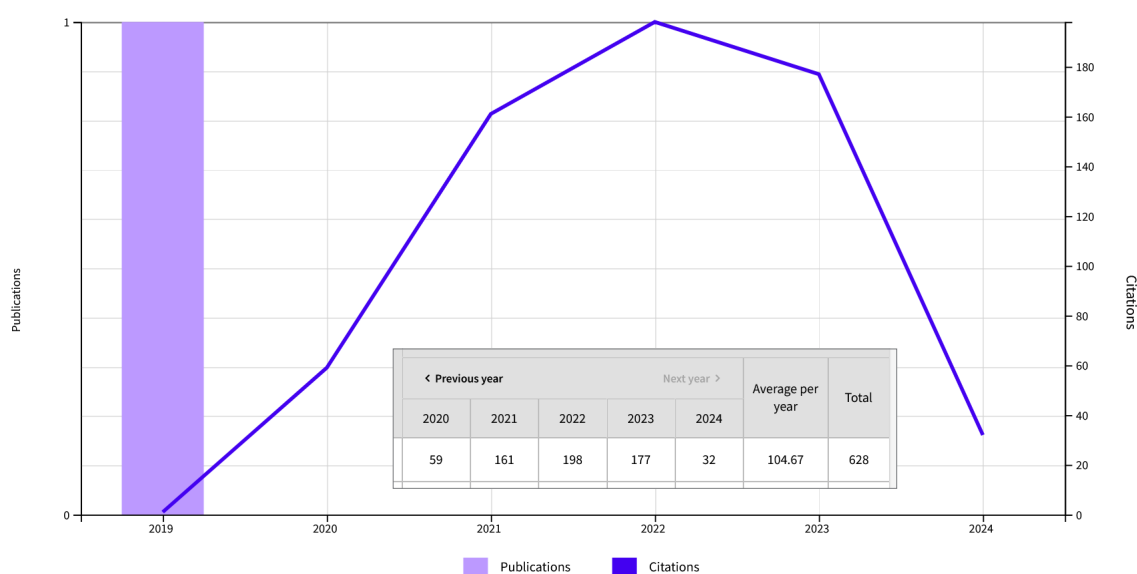

Rajak, D.K., Pagar, D.D., Menezes, P.L., Linul, E. Fiber-Reinforced Polymer Composites: Manufacturing, Properties, and Applications, POLYMERS, Volume: 11, Issue: 10, Article Number: 1667, PubMed ID: 31614875, eISSN: 2073-4360, 2019;  
Times Cited in Web of Science Core Collection: 628

**Abstract:** Composites have been found to be the most promising and discerning material available in this century. Presently, composites reinforced with fibers of synthetic or natural materials are gaining more importance as demands for lightweight materials with high strength for specific applications are growing in the market. Fiber-reinforced polymer composite offers not only high strength to weight ratio, but also reveals exceptional properties such as high durability; stiffness; damping property; flexural strength; and resistance to corrosion, wear, impact, and fire. These wide ranges of diverse features have led composite materials to find applications in mechanical, construction, aerospace, automobile, biomedical, marine, and many other manufacturing industries. Performance of composite

materials predominantly depends on their constituent elements and manufacturing techniques, therefore, functional properties of various fibers available worldwide, their classifications, and the manufacturing techniques used to fabricate the composite materials need to be studied in order to figure out the optimized characteristic of the material for the desired application. An overview of a diverse range of fibers, their properties, functionality, classification, and various fiber composite manufacturing techniques is presented to discover the optimized fiber-reinforced composite material for significant applications. Their exceptional performance in the numerous fields of applications have made fiber-reinforced composite materials a promising alternative over solitary metals or alloys.

## Web of Science - Clarivate Analytics Highly Cited Paper

As of January/December 2023, this highly cited paper received enough citations to place it in the top 1% of the academic field of **Environment/ Ecology** based on a highly cited threshold for the field and publication year.

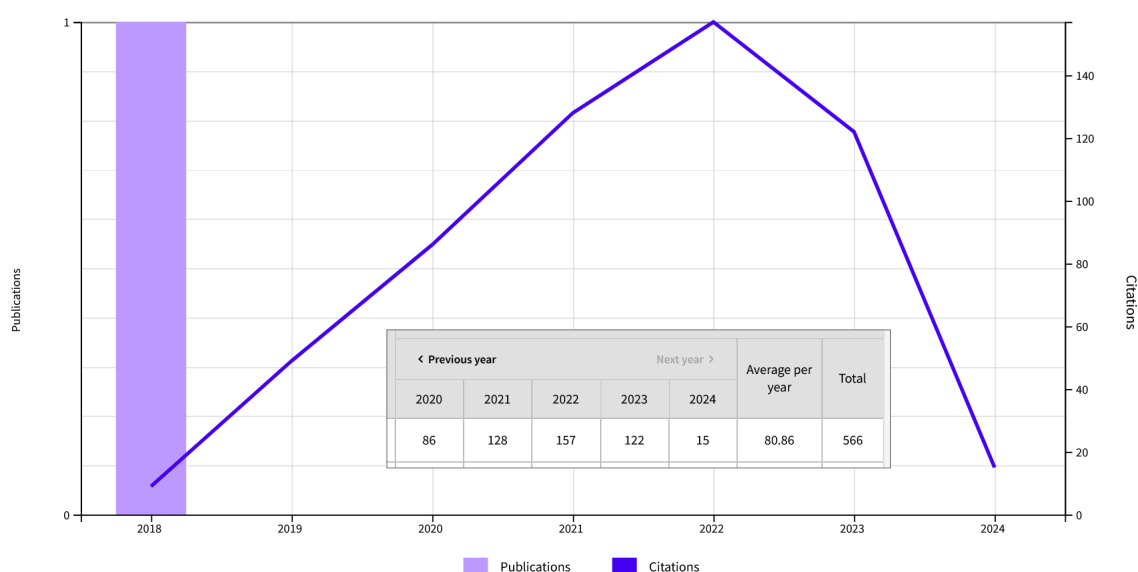

Sarbu, I., Sebarchievici, C. A Comprehensive Review of Thermal Energy Storage, SUSTAINABILITY, Volume: 10, Issue: 1, Article Number: 191, ISSN: 2071-1050, 2018;  
Times Cited in Web of Science Core Collection: 566

**Abstract:** Thermal energy storage (TES) is a technology that stocks thermal energy by heating or cooling a storage medium so that the stored energy can be used at a later time for heating and cooling applications and power generation. TES systems are used particularly in buildings and in industrial processes. This paper is focused on TES technologies that provide a way of valorizing solar heat and reducing the energy demand of buildings. The principles of several energy storage methods and calculation of storage capacities are

described. Sensible heat storage technologies, including water tank, underground, and packed-bed storage methods, are briefly reviewed. Additionally, latent-heat storage systems associated with phase-change materials for use in solar heating/cooling of buildings, solar water heating, heat-pump systems, and concentrating solar power plants as well as thermo-chemical storage are discussed. Finally, cool thermal energy storage is also briefly reviewed and outstanding information on the performance and costs of TES systems are included.

## Web of Science - Clarivate Analytics Highly Cited Paper

As of January/December 2023, this highly cited paper received enough citations to place it in the top 1% of the academic field of **Engineering** based on a highly cited threshold for the field and publication year.



Boldea, I., Tutelea, L.N., Parsa, L., Dorrell, D. Automotive Electric Propulsion Systems With Reduced or No Permanent Magnets: An Overview, IEEE TRANSACTIONS ON INDUSTRIAL ELECTRONICS, Volume: 61, Issue: 10, Pages: 5696-5711, ISSN: 0278-0046, eISSN: 1557-9948, 2014; Times Cited in Web of Science Core Collection: 549

**Abstract:** Hybrid and electric vehicle technology has seen rapid development in recent years. The motor and the generator are at the heart of the vehicle drive and energy system and often utilize expensive rare-earth permanent magnet (PM) material. This paper reviews and addresses the research work that has been carried out to reduce the amount of rare-earth material that is used while maintaining the high efficiency and performance that rare-earth PM machines offer. These new machines can use either less rare-earth PM material,

weaker ferrite magnets, or no magnets; and they need to meet the high performance that the more usual interior PM synchronous motor with sintered neodymium-iron-boron magnets provides. These machines can take the form of PM-assisted synchronous reluctance machines, induction machines, switched reluctance machines, wound rotor synchronous machines (claw pole or biaxially excited), double-saliency machines with ac or dc stator current control, or brushless dc multiple-phase reluctance machines.

## Web of Science - Clarivate Analytics Highly Cited Paper

As of January/December 2023, this highly cited paper received enough citations to place it in the top 1% of the academic field of **Engineering** based on a highly cited threshold for the field and publication year.

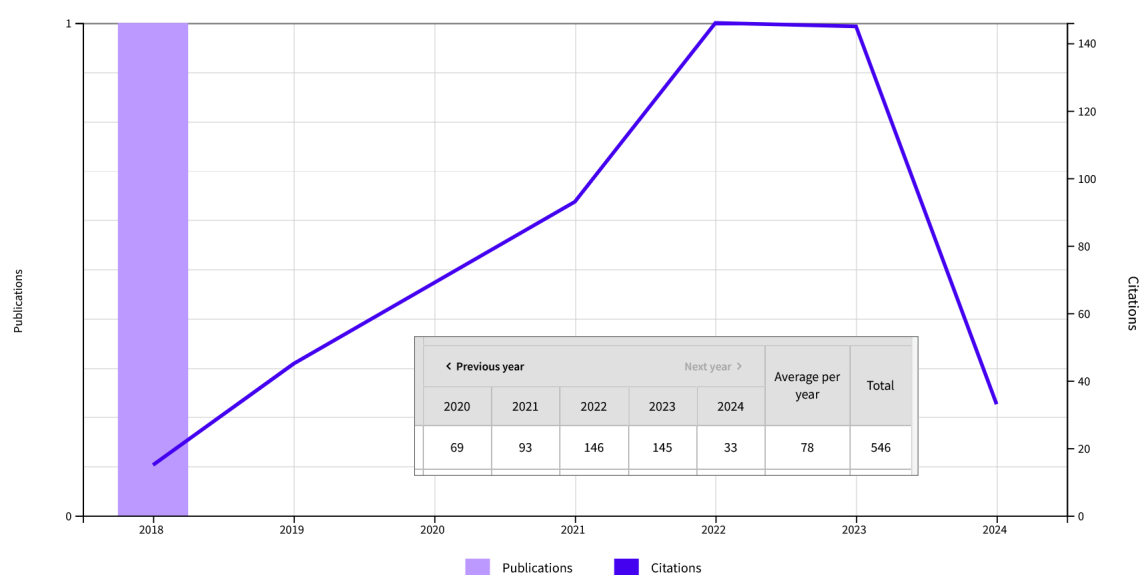

Ancuti, C.O., Ancuti, C., De Vleeschouwer, C., Bekaert, P. Color Balance and Fusion for Underwater Image Enhancement, IEEE TRANSACTIONS ON IMAGE PROCESSING, Volume: 27, Issue: 1, Pages: 379-393, PubMed ID: 28981416, ISSN: 1057-7149, eISSN: 1941-0042, 2018; Times Cited in Web of Science Core Collection: 546

**Abstract:** We introduce an effective technique to enhance the images captured underwater and degraded due to the medium scattering and absorption. Our method is a single image approach that does not require specialized hardware or knowledge about the underwater conditions or scene structure. It builds on the blending of two images that are directly derived from a color-compensated and white-balanced version of the original degraded image. The two images to fusion, as well as their associated weight maps, are defined to promote the transfer of edges and color contrast to the output

image. To avoid that the sharp weight map transitions create artifacts in the low frequency components of the reconstructed image, we also adapt a multiscale fusion strategy. Our extensive qualitative and quantitative evaluation reveals that our enhanced images and videos are characterized by better exposedness of the dark regions, improved global contrast, and edges sharpness. Our validation also proves that our algorithm is reasonably independent of the camera settings, and improves the accuracy of several image processing applications, such as image segmentation and keypoint matching.

## Web of Science - Clarivate Analytics Highly Cited Paper

As of January/December 2023, this highly cited paper received enough citations to place it in the top 1% of the academic field of **Engineering** based on a highly cited threshold for the field and publication year.



Sarbu, I., Sebarchievici, C. General review of ground-source heat pump systems for heating and cooling of buildings, *ENERGY AND BUILDINGS*, Volume: 70, Pages: 441-454, ISSN: 0378-7788, eISSN: 1872-6178, 2014;  
Times Cited in Web of Science Core Collection: 411

**Abstract:** A large number of ground-source heat pumps (GSHP) systems have been used in residential and commercial buildings throughout the world due to the attractive advantages of high energy and environmental performances. The GSHPs are proven renewable energy technology for space heating and cooling. This paper provides a detailed literature review of the GSHP systems, and their recent advances. The operation principle and energy efficiency of a heat pump are defined first. Then, a general introduction on the GSHPs and its development, and a detailed description of the surface water (SWHP), ground-water (GWHP), and ground-couplet (GCHP) heat pumps are performed. The most typical simulation and ground thermal response

test models for the vertical ground heat exchangers currently available are summarized including the heat transfer processes outside and inside the boreholes. Also, some information about a new GWHP using a heat exchanger with special construction, and the possibility to obtain the better energy efficiency with combined heating and cooling by GCHP are presented. The various hybrid GCHP systems for cooling or heating-dominated buildings are well described. Finally, the energy, economic and environmental performance of a closed-loop GCHP system is also briefly reviewed. It is found that the GSHP technology can be used both in cold and hot weather areas and the energy saving potential is significant.

## Web of Science - Clarivate Analytics Highly Cited Paper

As of January/December 2023, this highly cited paper received enough citations to place it in the top 1% of the academic field of **Economics & Business** based on a highly cited threshold for the field and publication year.

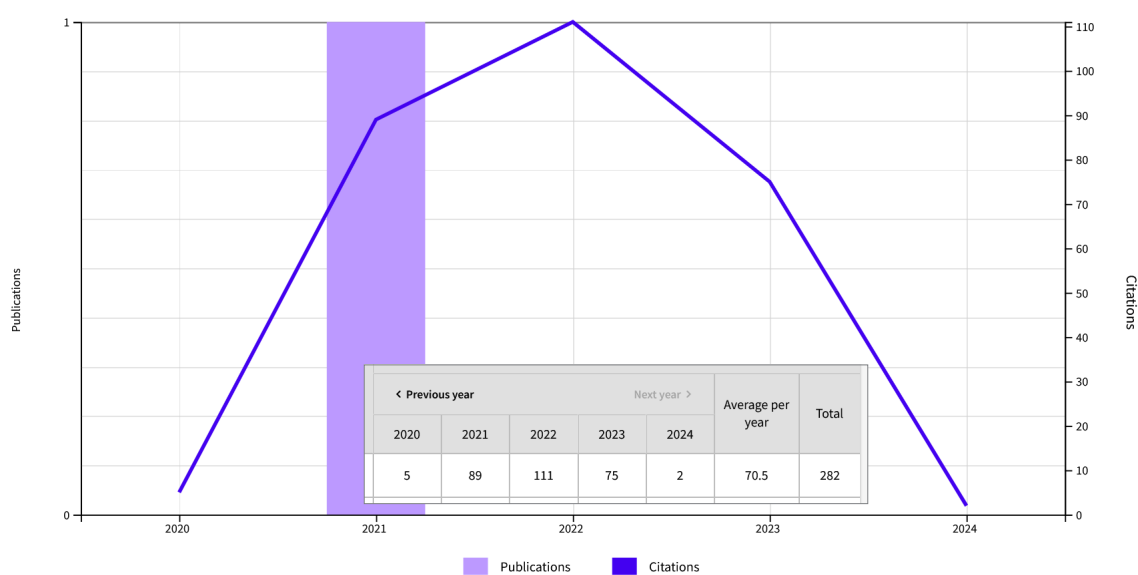

Albulescu, C.T. COVID-19 and the United States financial markets' volatility, *FINANCE RESEARCH LETTERS*, Volume: 38, Article Number: 101699, PubMed ID: 32837380, ISSN: 1544-6123, eISSN: 1544-6131, 2021;  
Times Cited in Web of Science Core Collection: 282

**Abstract:** We empirically investigate the effect of the official announcements regarding the COVID-19 new cases of infection and fatality ratio, on the financial markets volatility in the United States (US). We consider both COVID-19 global and US figures and show

that the sanitary crisis enhances the S&P 500 realized volatility. Our findings are robust to different model specifications and suggest that the prolongation of the coronavirus pandemic is an important source of financial volatility, challenging the risk management activity.

## Web of Science - Clarivate Analytics Highly Cited Paper

As of January/December 2023, this highly cited paper received enough citations to place it in the top 1% of the academic field of **Chemistry** based on a highly cited threshold for the field and publication year.

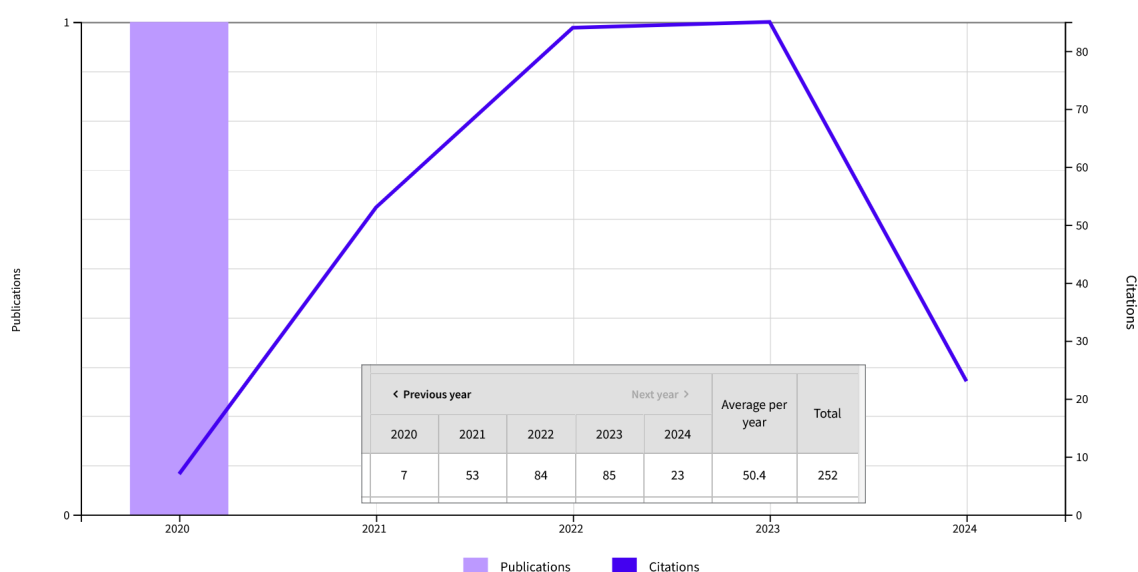

Covaci, C., Gontean, A. Piezoelectric Energy Harvesting Solutions: A Review, *SENSORS*, Volume: 20, Issue: 12, Article Number: 3512, PubMed ID: 32575888, eISSN: 1424-8220, 2020;  
Times Cited in Web of Science Core Collection: 252

**Abstract:** The goal of this paper is to review current methods of energy harvesting, while focusing on piezoelectric energy harvesting. The piezoelectric energy harvesting technique is based on the materials' property of generating an electric field when a mechanical force is applied. This phenomenon is known as the direct piezoelectric effect. Piezoelectric transducers can be of different shapes and materials,

making them suitable for a multitude of applications. To optimize the use of piezoelectric devices in applications, a model is needed to observe the behavior in the time and frequency domain. In addition to different aspects of piezoelectric modeling, this paper also presents several circuits used to maximize the energy harvested.

## Web of Science - Clarivate Analytics Highly Cited Paper

As of January/December 2023, this highly cited paper received enough citations to place it in the top 1% of the academic field of **Engineering** based on a highly cited threshold for the field and publication year.

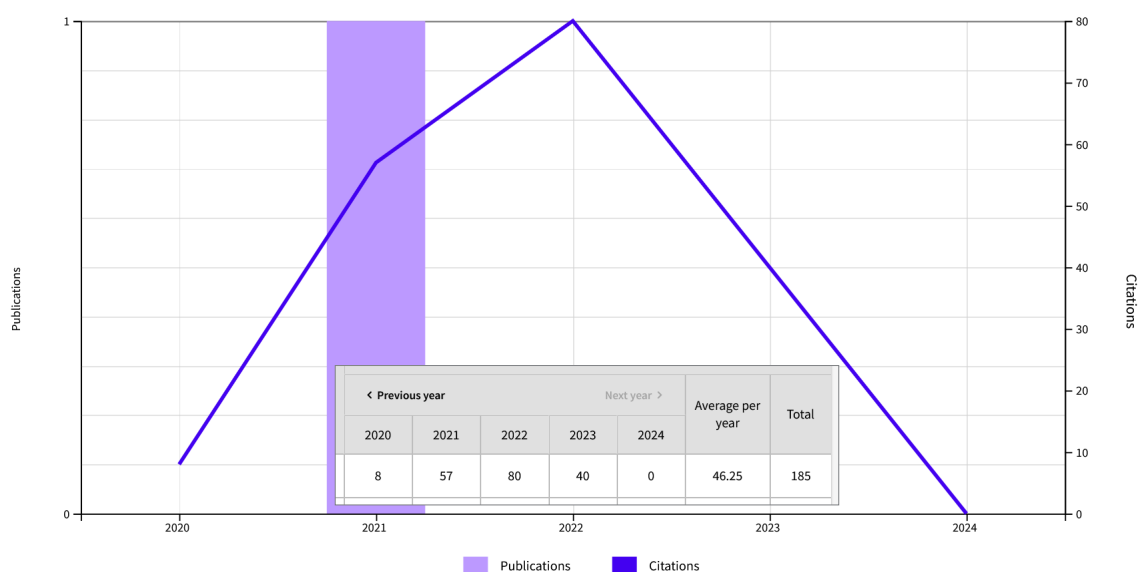

Roman, R.C., Precup, R.E., Petriu, E.M. Hybrid data-driven fuzzy active disturbance rejection control for tower crane systems, EUROPEAN JOURNAL OF CONTROL, Volume: 58, Pages: 373-387, ISSN: 0947-3580, eISSN: 1435-5671, 2021;  
Times Cited in Web of Science Core Collection: 185

**Abstract:** This paper proposes the Virtual Reference Feedback Tuning (VRFT) of a combination of two control algorithms, Active Disturbance Rejection Control (ADRC) as a representative data-driven (or model-free) control algorithm and fuzzy control, in order to exploit the advantages of data-driven control and fuzzy control. The combination of Active Disturbance Rejection Control with Proportional-Derivative Takagi-Sugeno Fuzzy Control (PDTSF) tuned by Virtual Reference Feedback Tuning results in two novel data-driven algorithms referred to as hybrid data-driven fuzzy ADRC algorithms. The main benefit of this combination is the automatic optimal tuning in a model-free manner of the parameters of the combination of Active Disturbance Rejection Control with Proportional-Derivative Takagi-Sugeno Fuzzy Control called ADRC-PDTSF. The second benefit is that the suggested combination is time saving in finding the optimal parameters of the controllers. However, since Virtual Reference Feedback Tuning generally

works with linear controllers to solve a certain optimization problem and the fuzzy controllers are essentially non-linear, this paper replaces the least-squares algorithm specific to Virtual Reference Feedback Tuning with a metaheuristic optimization algorithm, i.e. Grey Wolf Optimizer. The fuzzy control system stability is guaranteed by including a limit cycle-based stability analysis approach in Grey Wolf Optimizer algorithm to validate the next solution candidates. The hybrid data-driven fuzzy ADRC algorithms are validated as controllers in terms of real-time experiments conducted on three-degree-of-freedom tower crane system laboratory equipment. To determine the efficiency of the new hybrid data-driven fuzzy ADRC algorithms, their performance is compared experimentally with that of two control algorithms, namely Active Disturbance Rejection Control with Proportional-Derivative Takagi-Sugeno Fuzzy Control, whose parameters are optimally tuned by Grey Wolf Optimizer in a model-based manner using the nonlinear process model.



## Web of Science - Clarivate Analytics Highly Cited Paper

As of January/December 2023, this highly cited paper received enough citations to place it in the top 1% of the academic field of **Engineering** based on a highly cited threshold for the field and publication year.

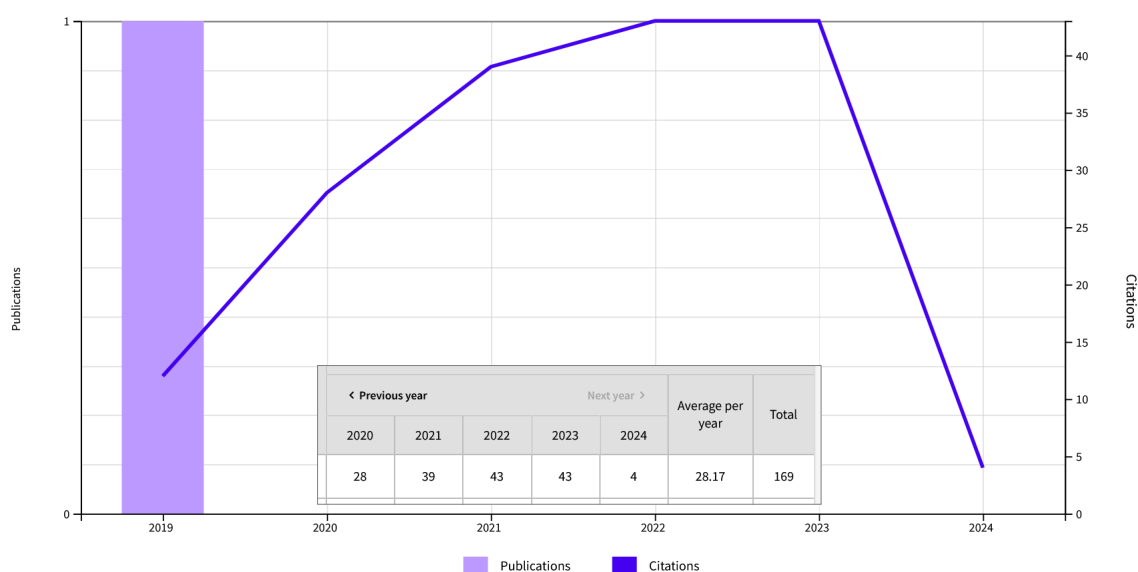

Sarbu, I., Dorca, A. Review on heat transfer analysis in thermal energy storage using latent heat storage systems and phase change materials, INTERNATIONAL JOURNAL OF ENERGY RESEARCH, Volume: 43, Issue: 1, Pages: 29-64, ISSN: 0363-907X, eISSN: 1099-114X, 2019; Times Cited in Web of Science Core Collection: 169

**Abstract:** Thermal energy storage (TES) is a technology that stocks thermal energy by heating or cooling a storage medium so that the stored energy can be used later for heating and cooling applications and for power generation. TES has recently attracted increasing interest to thermal applications such as space and water heating, waste heat utilisation, cooling, and air conditioning. Phase change materials (PCMs) used for the storage of thermal energy as latent heat are special types of advanced materials that substantially contribute to the efficient use and conservation of waste heat and solar energy. This paper provides a comprehensive review on the development of latent heat storage (LHS) systems focused on heat transfer and enhancement techniques employed in PCMs to effectively charge and discharge

latent heat energy, and the formulation of the phase change problem. The main categories of PCMs are classified and briefly described, and heat transfer enhancement technologies, namely dispersion of low-density materials, use of porous materials, metal matrices and encapsulation, incorporation of extended surfaces and fins, utilisation of heat pipes, cascaded storage, and direct heat transfer techniques, are also discussed in detail. Additionally, a two-dimensional heat transfer simulation model of an LHS system is developed using the control volume technique to solve the phase change problem. Furthermore, a three-dimensional numerical simulation model of an LHS is built to investigate the quasi-steady state and transient heat transfer in PCMs. Finally, several future research directions are provided.

## Web of Science - Clarivate Analytics Highly Cited Paper

As of January/June 2023, this highly cited paper received enough citations to place it in the top 1% of the academic field of **Engineering** based on a highly cited threshold for the field and publication year.



Gheju, M., Balcu, I., Mosoarca, G. Removal of Cr(VI) from aqueous solutions by adsorption on MnO<sub>2</sub>, JOURNAL OF HAZARDOUS MATERIALS, Volume: 310, Pages: 270-277, PubMed ID: 26947189, ISSN: 0304-3894, eISSN: 1873-3336, 2016;  
Times Cited in Web of Science Core Collection: 162

**Abstract:** Adsorption of Cr(VI) on MnO<sub>2</sub> was investigated with respect to effect of pH, temperature, ionic strength, initial Cr(VI) concentration, co-presence of different anions (HCO<sub>3</sub><sup>-</sup>, SO<sub>4</sub><sup>2-</sup>, H<sub>2</sub>PO<sub>4</sub><sup>-</sup>, NO<sub>3</sub><sup>-</sup> and Cl<sup>-</sup>) and of low molecular weight natural organic materials (LMWNOM) (acetate, oxalate and citrate). The process was rapid during the first 3-5 min, reaching equilibrium after one hour. Adsorption decreased with increasing pH, temperature and Cr(VI) initial concentration, and increased with increasing ionic strength. Co-presence of phosphate, sulfate, bicarbonate, citrate and oxalate hindered Cr(VI) adsorption, whereas nitrate, chloride and acetate did not exert any notable influence. The overall order of Cr(VI) adsorption suppression due to

co-presence of anions and LMWNOM was H<sub>2</sub>PO<sub>4</sub><sup>-</sup> > HCO<sub>3</sub><sup>-</sup> > SO<sub>4</sub><sup>2-</sup>, and oxalate > citrate, respectively. Highest experimental equilibrium sorption capacity (0.83 mg g<sup>-1</sup>) was obtained at 20 degrees C and pH 5.9, while lowest (0.18 mg g<sup>-1</sup>) was noticed in the co-presence of H<sub>2</sub>PO<sub>4</sub><sup>-</sup>, at 20 degrees C and pH 6.9. Adsorption kinetics was successfully fitted by pseudo-second-order model. Mechanisms for both specific and non-specific adsorption are likely to be involved, while rate-controlling step involved both intra-particle and film diffusion processes. Cr(VI) was strongly bound to MnO<sub>2</sub>, which makes risks of its subsequent liberation into the environment to be low.

## Web of Science - Clarivate Analytics Highly Cited Paper

As of July/December 2023, this highly cited paper received enough citations to place it in the top 1% of the academic field of **Chemistry** based on a highly cited threshold for the field and publication year.

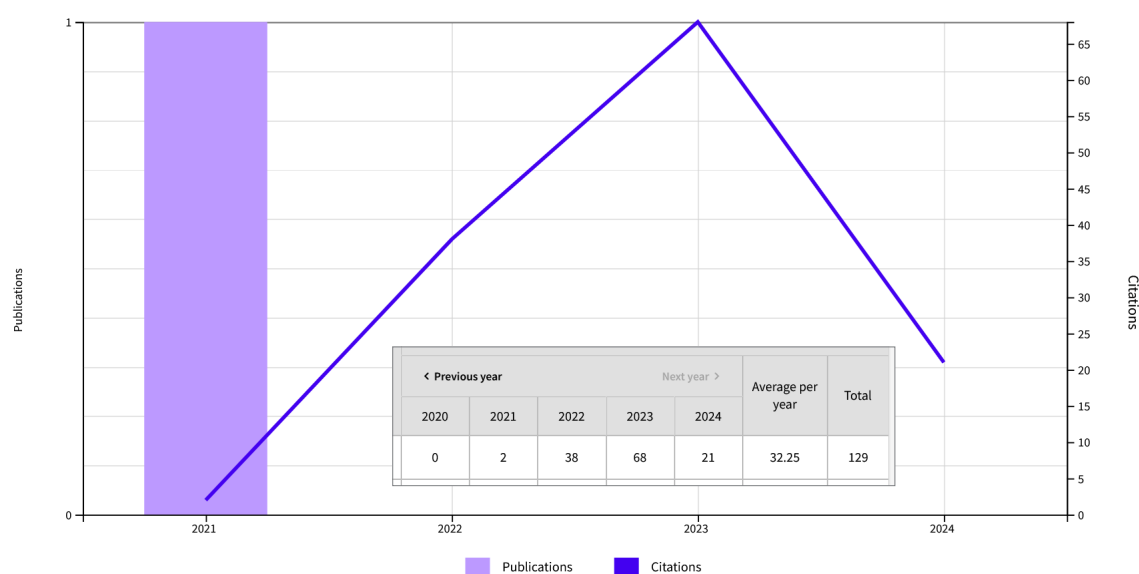

Ardean, C., Davidescu, C.M., Nemes, N.S., Negrea, A., Ciopec, M., Duteanu, N., Negrea, P., Duda-Seiman, D., Musta, V. Factors Influencing the Antibacterial Activity of Chitosan and Chitosan Modified by Functionalization, *INTERNATIONAL JOURNAL OF MOLECULAR SCIENCES*, Volume: 22, Issue: 14, Article Number: 7449, PubMed ID: 34299068, eISSN: 1422-0067, 2021;  
Times Cited in Web of Science Core Collection: 129

**Abstract:** The biomedical and therapeutic importance of chitosan and chitosan derivatives is the subject of interdisciplinary research. In this analysis, we intended to consolidate some of the recent discoveries regarding the potential of chitosan and its derivatives to be used for biomedical and other purposes. Why chitosan? Because chitosan is a natural biopolymer that can be obtained from one of the most abundant polysaccharides in nature, which is chitin. Compared to other biopolymers, chitosan presents some advantages, such as accessibility, biocompatibility, biodegradability, and no toxicity, expressing significant antibacterial potential. In addition, through chemical processes, a high number of chitosan derivatives can be obtained with many possibilities for use. The presence of several types of functional groups in the structure of the polymer and the fact that it has cationic properties are determinant for the increased

reactive properties of chitosan. We analyzed the intrinsic properties of chitosan in relation to its source: the molecular mass, the degree of deacetylation, and polymerization. We also studied the most important extrinsic factors responsible for different properties of chitosan, such as the type of bacteria on which chitosan is active. In addition, some chitosan derivatives obtained by functionalization and some complexes formed by chitosan with various metallic ions were studied. The present research can be extended in order to analyze many other factors than those mentioned. Further in this paper were discussed the most important factors that influence the antibacterial effect of chitosan and its derivatives. The aim was to demonstrate that the bactericidal effect of chitosan depends on a number of very complex factors, their knowledge being essential to explain the role of each of them for the bactericidal activity of this biopolymer.

## Web of Science - Clarivate Analytics Highly Cited Paper

As of January/December 2023, this highly cited paper received enough citations to place it in the top 1% of the academic field of **Engineering** based on a highly cited threshold for the field and publication year.

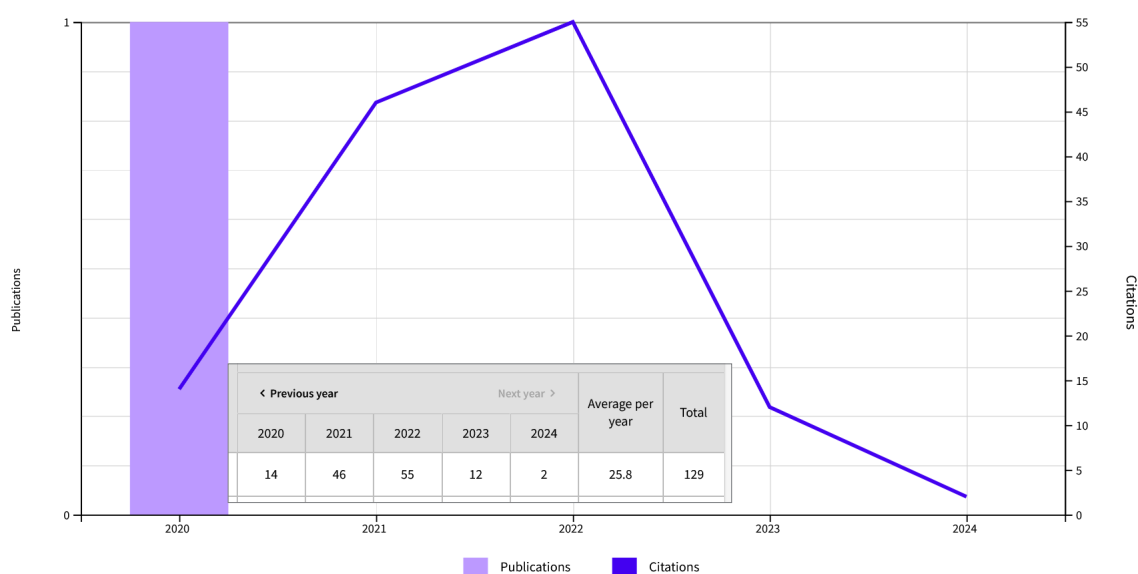

Precup, R.E., Teban, T.A., Albu, A., Borlea, A.B., Zamfirache, I.A., Petriu, E.M. Evolving Fuzzy Models for Prosthetic Hand Myoelectric-Based Control, IEEE TRANSACTIONS ON INSTRUMENTATION AND MEASUREMENT, Volume: 69, Issue: 7, Pages: 4625-4636, ISSN: 0018-9456, eISSN: 1557-9662, 2020;

Times Cited in Web of Science Core Collection: 129

**Abstract:** This article applies an incremental online identification algorithm to develop a set of evolving fuzzy models (FMs) that characterize the nonlinear finger dynamics of the human hand for the myoelectric (ME)-based control of a prosthetic hand. The FM inputs are the ME signals obtained from eight ME sensors and past inputs and/or outputs. The FM outputs are the finger angles, considered here as the midcarpal joint angles, to ensure their control. The best evolving FMs that characterize each of the five fingers are described with the results validated on real data. Simple second-order linear models are

next given to enable the cost-effective controller design. Five separate control loops are proposed, with proportional-integral (PI) controllers separately tuned by a frequency-domain approach. Simple PI-fuzzy controllers are designed starting with the linear PI controllers to ensure the control system performance improvement. The evolving FMs are used to simulate accurately the behavior of the human hand. Digital simulation results are included to show the effectiveness of the PI-fuzzy controllers and the performance improvement in comparison to the initial PI ones.

## Web of Science - Clarivate Analytics Highly Cited Paper

As of January/December 2023, this highly cited paper received enough citations to place it in the top 1% of the academic field of **Computer Science** based on a highly cited threshold for the field and publication year.

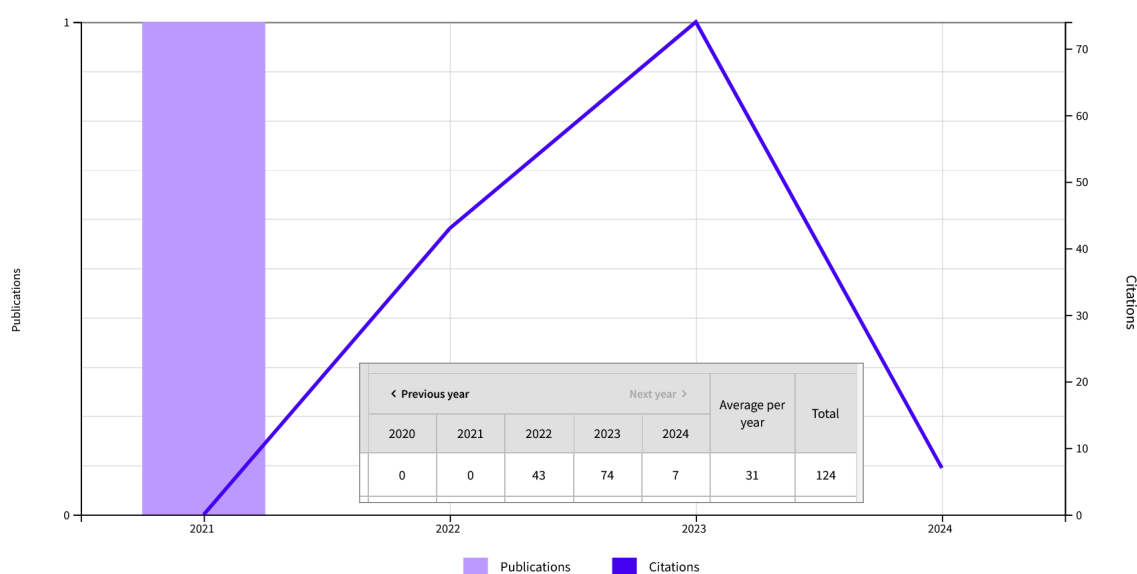

Zamfirache, I.A., Precup, R.E., Roman, R.C., Petriu, E.M. Policy Iteration Reinforcement Learning-based control using a Grey Wolf Optimizer algorithm, INFORMATION SCIENCES, Volume: 585, Pages: 162-175, ISSN: 0020-0255, eISSN: 1872-6291, 2021; Times Cited in Web of Science Core Collection: 124

**Abstract:** This paper presents a new Reinforcement Learning (RL)-based control approach that uses the Policy Iteration (PI) and a metaheuristic Grey Wolf Optimizer (GWO) algorithm to train the Neural Networks (NNs). Due to an efficient tradeoff to exploration and exploitation, the GWO algorithm shows good results in NN training and solving complex optimization problems. The proposed approach is compared to the classical PI RL-based control approach using the Gradient Descent (GD) algorithm, and with the RL-based control approach which uses the metaheuristic Particle Swarm Optimization (PSO) algorithm. The experiments are conducted using a nonlinear servo system laboratory equipment. Each approach evaluated on

how well it solves the optimal reference tracking control for an experimental servo system position control system. The policy NNs specific to all three approaches are implemented as state feedback with integrator controllers to remove the steady-state control errors and thus ensure the convergence of the objective function. Because of the random nature of metaheuristic algorithms, the experiments for GWO and PSO algorithms are run multiple times and the results are averaged before the conclusions are presented. The experimental results shows that for the control objective considered in this paper, the GWO algorithm represents a better solution compared to GD and PSO algorithms.

## Web of Science - Clarivate Analytics Highly Cited Paper

As of January/December 2023, this highly cited paper received enough citations to place it in the top 1% of the academic field of **Geosciences** based on a highly cited threshold for the field and publication year.

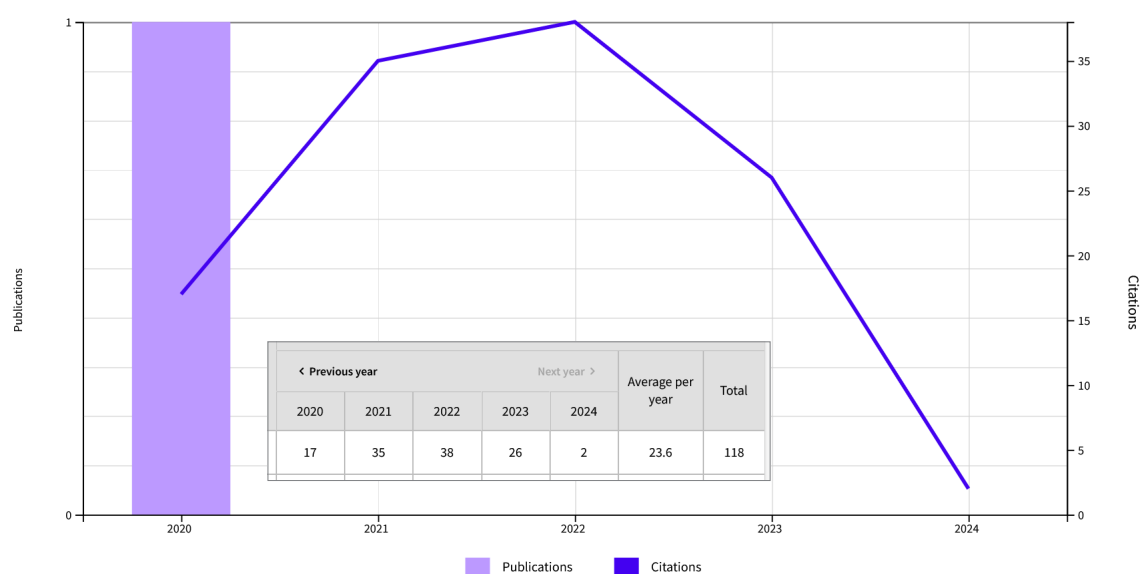

Tmusic, G., Manfreda, S., Aasen, H., James, M.R., Goncalves, G., Ben-Dor, E., Brook, A., Polinova, M., Arranz, J.J., Meszaros, J., Zhuang, R.D., Johansen, K., Malbeteau, Y., de Lima, I.P., Davids, C., Herban, S., McCabe, M.F. Current Practices in UAS-based Environmental Monitoring, *REMOTE SENSING*, Volume: 12, Issue: 6, Article Number: 1001, eISSN: 2072-4292, 2020; Times Cited in Web of Science Core Collection: 118

**Abstract:** With the increasing role that unmanned aerial systems (UAS) are playing in data collection for environmental studies, two key challenges relate to harmonizing and providing standardized guidance for data collection, and also establishing protocols that are applicable across a broad range of environments and conditions. In this context, a network of scientists are cooperating within the framework of the Harmonious Project to develop and promote harmonized mapping strategies and disseminate operational guidance to ensure best practice for data collection and interpretation. The culmination of these efforts is summarized in the present manuscript. Through

this synthesis study, we identify the many interdependencies of each step in the collection and processing chain, and outline approaches to formalize and ensure a successful workflow and product development. Given the number of environmental conditions, constraints, and variables that could possibly be explored from UAS platforms, it is impractical to provide protocols that can be applied universally under all scenarios. However, it is possible to collate and systematically order the fragmented knowledge on UAS collection and analysis to identify the best practices that can best ensure the streamlined and rigorous development of scientific products.

## Web of Science - Clarivate Analytics Highly Cited Paper

As of January/December 2023, this highly cited paper received enough citations to place it in the top 1% of the academic field of **Engineering** based on a highly cited threshold for the field and publication year.

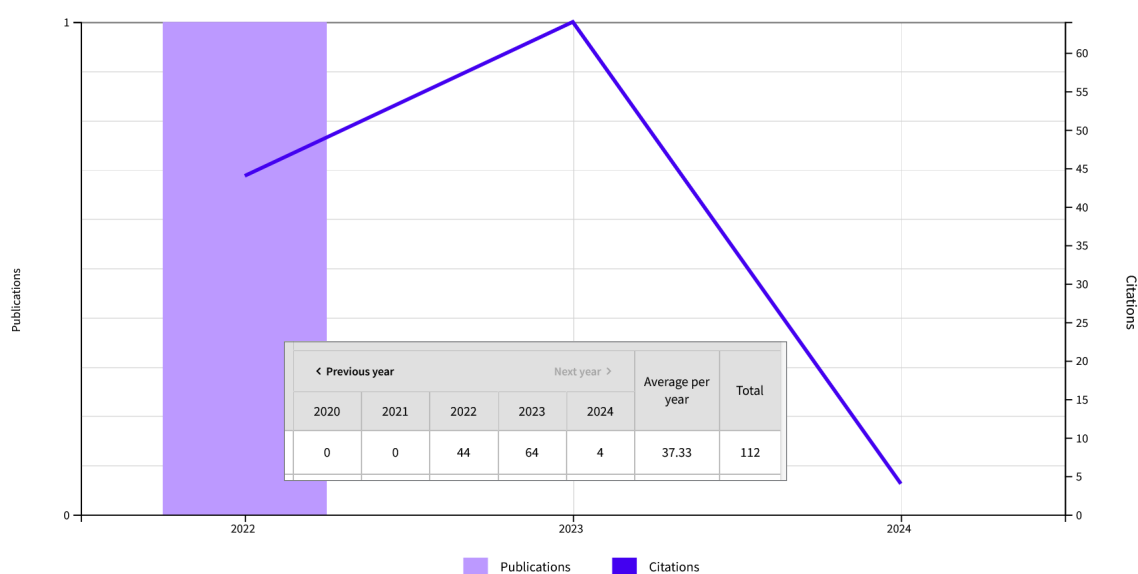

Pozna, C., Precup, R.E., Horvath, E., Petriu, E.M. Hybrid Particle Filter-Particle Swarm Optimization Algorithm and Application to Fuzzy Controlled Servo Systems, IEEE TRANSACTIONS ON FUZZY SYSTEMS, Volume: 30, Issue: 10, Pages: 4286-4297, ISSN: 1063-6706, eISSN: 1941-0034, 2022; Times Cited in Web of Science Core Collection: 112

**Abstract:** This article presents a hybrid metaheuristic optimization algorithm that combines particle filter (PF) and particle swarm optimization (PSO) algorithms. The new PF-PSO algorithm consists of two steps: the first generates randomly the particle population; and the second zooms the search domain. An application of this algorithm to the optimal tuning of proportional-integral-fuzzy controllers

for the position control of a family of integral-type servo systems is then presented as a second contribution. The reduction in PF-PSO algorithm's cost function allows for reduced energy consumption of the fuzzy control system. A comparison with other metaheuristic algorithms on canonical test functions and experimental results are presented at the end of this article.

## Web of Science - Clarivate Analytics Highly Cited Paper

As of January/December 2023, this highly cited paper received enough citations to place it in the top 1% of the academic field of **Computer Science** based on a highly cited threshold for the field and publication year.

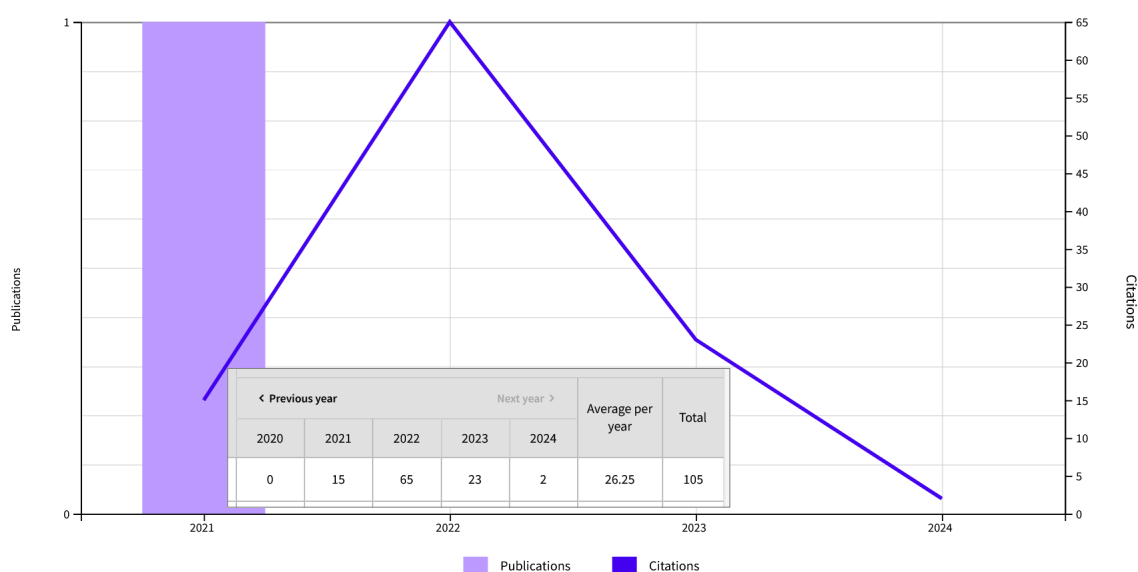

Borlea, I.D., Precup, R.E., Borlea, A.B., Ierican, D. A Unified Form of Fuzzy C-Means and K-Means algorithms and its Partitional Implementation, KNOWLEDGE-BASED SYSTEMS, Volume: 214, Article Number: 106731, ISSN: 0950-7051, eISSN: 1872-7409, 2021;  
Times Cited in Web of Science Core Collection: 105

**Abstract:** This paper proposes as an element of novelty the Unified Form (UF) clustering algorithm, which treats Fuzzy C-Means (FCM) and K-Means (KM) algorithms as a single configurable algorithm. UF algorithm was designed to facilitate the FCM and KM algorithms software implementation by offering a solution to implement a single algorithm, which can be configured to work as FCM or KM. The second element of novelty of this paper is the Partitional Implementation of Unified Form (PIUF) algorithm, which is built upon the UF algorithm and designed to solve in an elegant manner the challenges of processing large datasets in a sequential manner and the scalability of the UF algorithm for processing datasets of any size. PIUF algorithm has the advantage of overcoming any possible hardware limitations that can occur if large volumes of data are processed (required to be stored, loaded in memory and processed by a certain specified computational system). PIUF algorithm is designed and formulated

to be used on a single machine if the processed dataset is very big and it cannot be entirely loaded in the memory; at the same time it can be scaled to multiple processing nodes for reducing the processing time required to find the optimal solution. UF and PIUF algorithms are implemented and validated in BigTim platform, which is a distributed platform developed by the authors, and offers support for processing various datasets in a parallel manner but they can be implemented in any other data processing platforms. The Iris dataset is considered and next modified to obtain different datasets of different sizes in order to test the algorithms implementations in BigTim platform in different configurations. The analysis of PIUF algorithm and the comparison with FCM, KM and DBSCAN clustering algorithms are carried out using two performance indices; three performance indices are employed to evaluate the quality of the obtained clusters.



## Web of Science - Clarivate Analytics Highly Cited Paper

As of January/December 2023, this highly cited paper received enough citations to place it in the top 1% of the academic field of **Psychiatry/ Psychology** based on a highly cited threshold for the field and publication year.

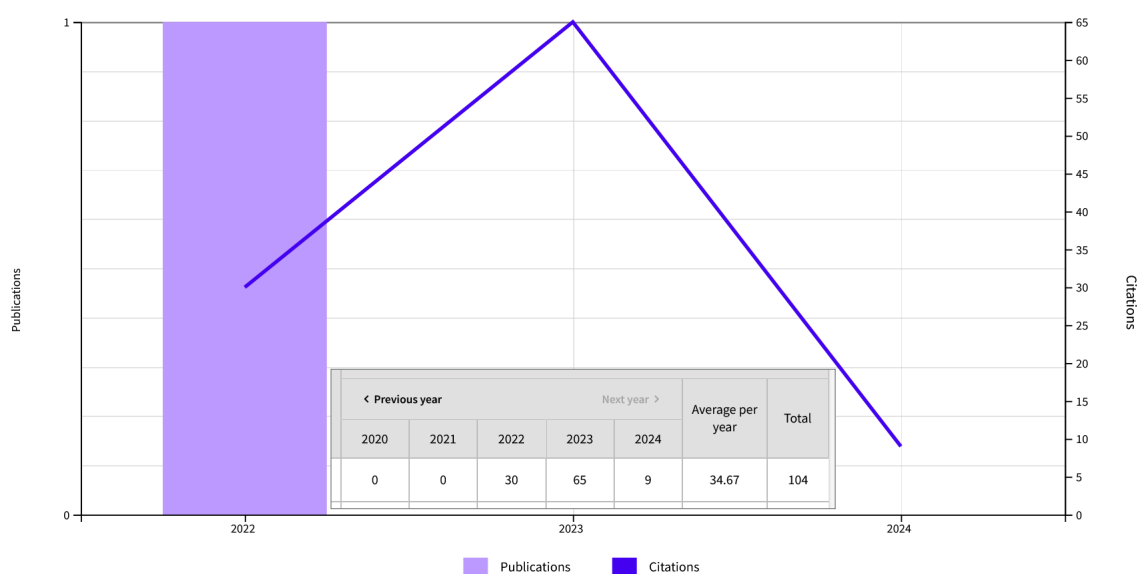

Yu, S.B., Abbas, J., Draghici, A., Negulescu, O.H., Ain, N.U. Social Media Application as a New Paradigm for Business Communication: The Role of COVID-19 Knowledge, Social Distancing, and Preventive Attitudes, *FRONTIERS IN PSYCHOLOGY*, Volume: 13, Article Number: 903082, PubMed ID: 35664180, ISSN: 1664-1078, 2022;  
Times Cited in Web of Science Core Collection: 104

**Abstract:** Business firms and the public have encountered massive consequences of the COVID-19 pandemic. This pandemic has become the most significant challenge and influenced all communities. This research study focuses on exploring the relationship between COVID-19 knowledge, social distancing, individuals' attitudes toward social media use, and practices of using social media amid the COVID-19 crisis. This study examines how attitudes toward social media use mediate the linkage between COVID-19 knowledge, social distancing, and practices for social media use. This survey uses a non-probability convenience sampling approach to collect samples and recruit willing respondents with their consent for data collection. This study recorded the feedback from 348 participants who encountered the indirect/direct effects of nationwide lockdowns, restrictions on social gatherings, and COVID-19 infection. The findings validate the

proposed hypotheses for their direct effects and indicate significant beta-values, t-statistics, and the p-values at  $p < 0.001$ . The results validate a relationship between the COVID-19 knowledge of and social distancing practices. Similarly, the results approved a positive link between social distancing and attitudes toward social media use amid COVID-19. The findings validate the relation between social distancing and attitudes toward social media use during COVID-19 challenges (beta-value = 0.22 and t-statistics = 3.078). The results show the linkage between attitudes toward social media use and practices of using social media (beta-value = 0.41, and t-statistics = 7.175). Individuals' attitude toward social media use during COVID-19 mediates the connection between COVID-19 knowledge and COVID-19 practices of using social media use. The results validate the first mediation at beta-value = 0.21 and t-statistic = 5.327.

...

## Web of Science - Clarivate Analytics Highly Cited Paper

As of January/December 2023, this highly cited paper received enough citations to place it in the top 1% of the academic field of **Computer Science** based on a highly cited threshold for the field and publication year.

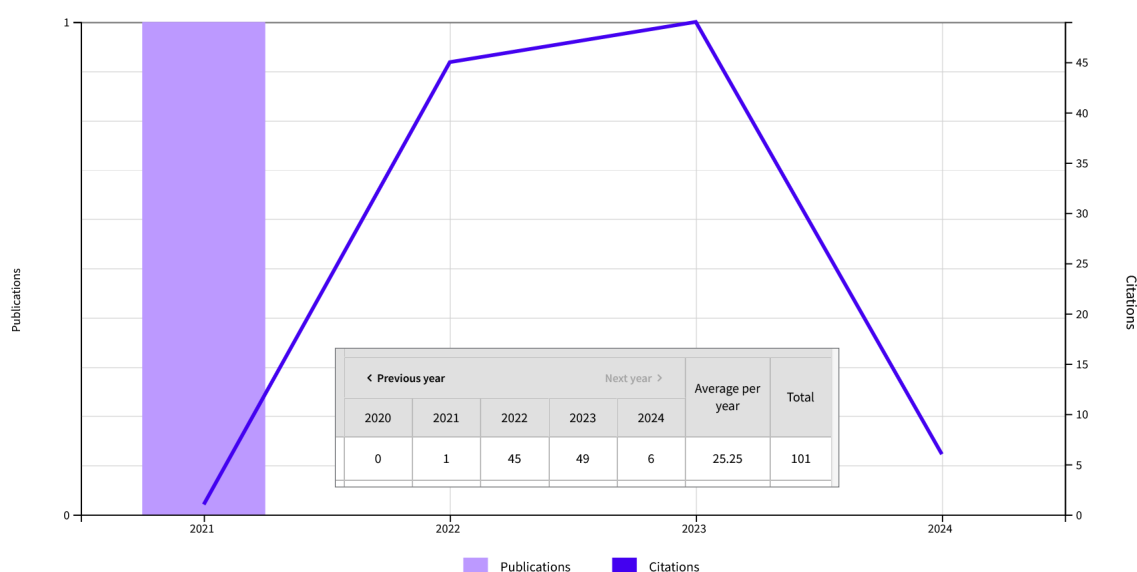

Zamfirache, I.A., Precup, R.E., Roman, R.C., Petriu, E.M. Reinforcement Learning-based control using Q-learning and gravitational search algorithm with experimental validation on a nonlinear servo system, INFORMATION SCIENCES, Volume: 583, Pages: 99-120, ISSN: 0020-0255, eISSN: 1872-6291, 2021;  
Times Cited in Web of Science Core Collection: 101

**Abstract:** This paper presents a novel Reinforcement Learning (RL)-based control approach that uses a combination of a Deep Q-Learning (DQL) algorithm and a metaheuristic Gravitational Search Algorithm (GSA). The GSA is employed to initialize the weights and the biases of the Neural Network (NN) involved in DQL in order to avoid the instability, which is the main drawback of the traditional randomly initialized NNs. The quality of a particular set of weights and biases is measured at each iteration of the GSA-based initialization using a fitness function aiming to achieve the predefined optimal control or learning objective. The data generated during the RL process is used in training a NN-based controller that will be able to autonomously

achieve the optimal reference tracking control objective. The proposed approach is compared with other similar techniques which use different algorithms in the initialization step, namely the traditional random algorithm, the Grey Wolf Optimizer algorithm, and the Particle Swarm Optimization algorithm. The NN-based controllers based on each of these techniques are compared using performance indices specific to optimal control as settling time, rise time, peak time, overshoot, and minimum cost function value. Real-time experiments are conducted in order to validate and test the proposed new approach in the framework of the optimal reference tracking control of a nonlinear position servo system. The experimental results show the superiority of this approach versus the other three competing approaches.

## Web of Science - Clarivate Analytics Highly Cited Paper

As of January/December 2023, this highly cited paper received enough citations to place it in the top 1% of the academic field of **Psychiatry/ Psychology** based on a highly cited threshold for the field and publication year.

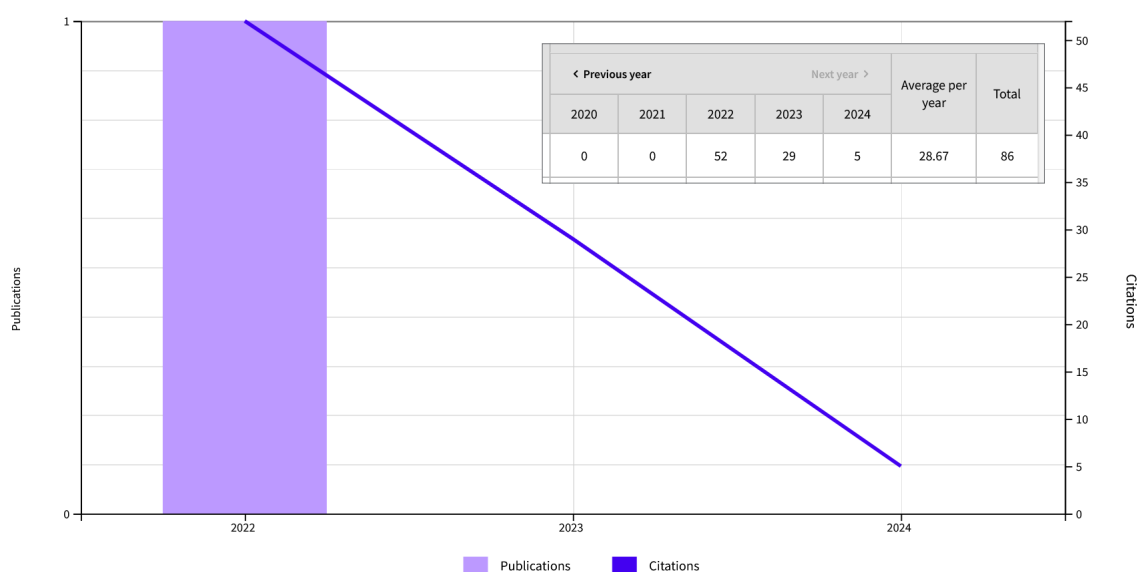

Zhou, Y.Y., Draghici, A., Abbas, J., Mubeen, R., Boatca, M.E., Salam, M.A. Social Media Efficacy in Crisis Management: Effectiveness of Non-pharmaceutical Interventions to Manage COVID-19 Challenges, FRONTIERS IN PSYCHIATRY, Volume: 12, Article Number: 626134, PubMed ID: 35197870, ISSN: 1664-0640, 2022;  
Times Cited in Web of Science Core Collection: 86

**Abstract:** The new identified virus COVID-19 has become one of the most contagious diseases in human history. The ongoing coronavirus has created severe threats to global mental health, which have resulted in crisis management challenges and international concerns related to health issues. As of September 9, 2021, there were over 223.4 million patients with COVID-19, including 4.6 million deaths and over 200 million recovered patients reported worldwide, which has made the COVID-19 outbreak one of the deadliest pandemics in human history. The aggressive public health implementations endorsed various precautionary safety and preventive strategies to suppress and minimize COVID-19 disease transmission. The second, third, and fourth waves of COVID-19 continue to pose global challenges to crisis management, as its evolution and implications are still unfolding. This study posits that examining the strategic ripostes and pandemic

experiences sheds light on combatting this global emergency. This study recommends two model strategies that help reduce the adverse effects of the pandemic on the immune systems of the general population. This present paper recommends NPI interventions (non-pharmaceutical intervention) to combine various measures, such as the suppression strategy (lockdown and restrictions) and mitigation model to decrease the burden on health systems. The current COVID-19 health crisis has influenced all vital economic sectors and developed crisis management problems. The global supply of vaccines is still not sufficient to manage this global health emergency. In this crisis, NPIs are helpful to manage the spillover impacts of the pandemic. It articulates the prominence of resilience and economic and strategic agility to resume economic activities and resolve healthcare issues.

...

## Web of Science - Clarivate Analytics Highly Cited Paper

As of January/December 2023, this highly cited paper received enough citations to place it in the top 1% of the academic field of **Engineering** based on a highly cited threshold for the field and publication year.

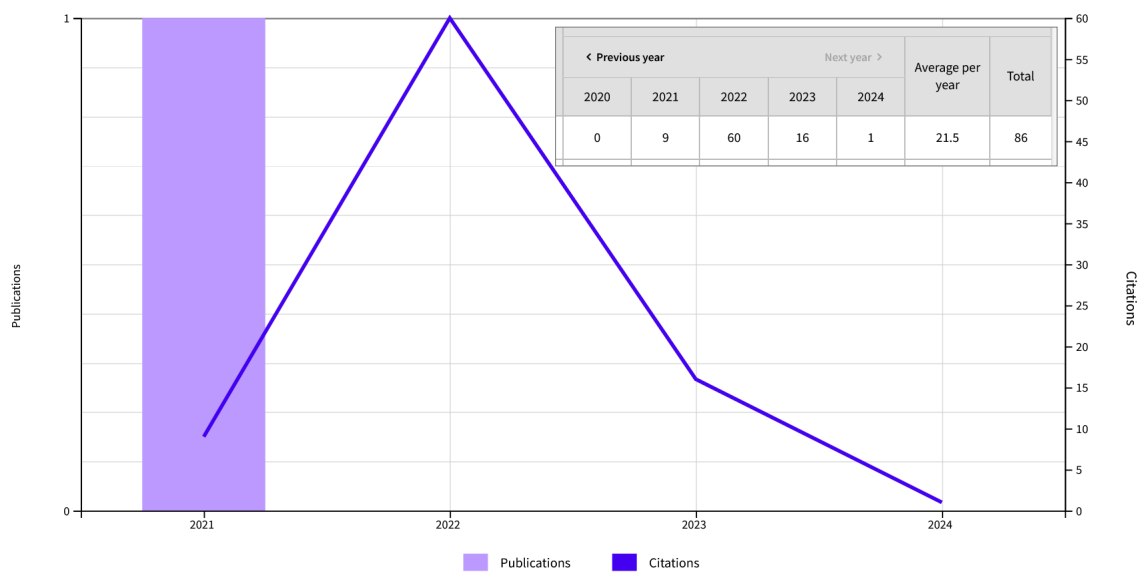

Precup, R.E., David, R.C., Roman, R.C., Szedlak-Stinean, A.I., Petriu, E.M. Optimal tuning of interval type-2 fuzzy controllers for nonlinear servo systems using Slime Mould Algorithm, INTERNATIONAL JOURNAL OF SYSTEMS SCIENCE, ISSN: 0020-7721, eISSN: 1464-5319, 2021; Times Cited in Web of Science Core Collection: 86

**Abstract:** This paper presents a novel application of the metaheuristic Slime Mould Algorithm (SMA) to the optimal tuning of interval type-2 fuzzy controllers. Inserting the information feedback model F1 in SMA leads to a new version of the metaheuristic algorithm, further referred to as SMAF1. The paper discusses implementation details specific to interval type-2 fuzzy controllers for the position control of processes modelled by nonlinear servo systems with an integral component and dead zone plus saturation nonlinearity. The linear

PI controllers are tuned on the basis of the Extended Symmetrical Optimum method using only one tuning parameter and next fuzzified to result in interval type-2 fuzzy controllers. The optimisation requires the minimisation of a discrete-time objective function expressed as the sum of time multiplied by squared control errors, and the vector variable is the parameter vector of the Mamdani PI fuzzy controller. Experimental results conclusively illustrate the superiority of SMAF1 and SMA in comparison with other metaheuristic algorithms.

## Web of Science - Clarivate Analytics Highly Cited Paper

As of September/December 2023, this highly cited paper received enough citations to place it in the top 1% of the academic field of **Computer Science** based on a highly cited threshold for the field and publication year.

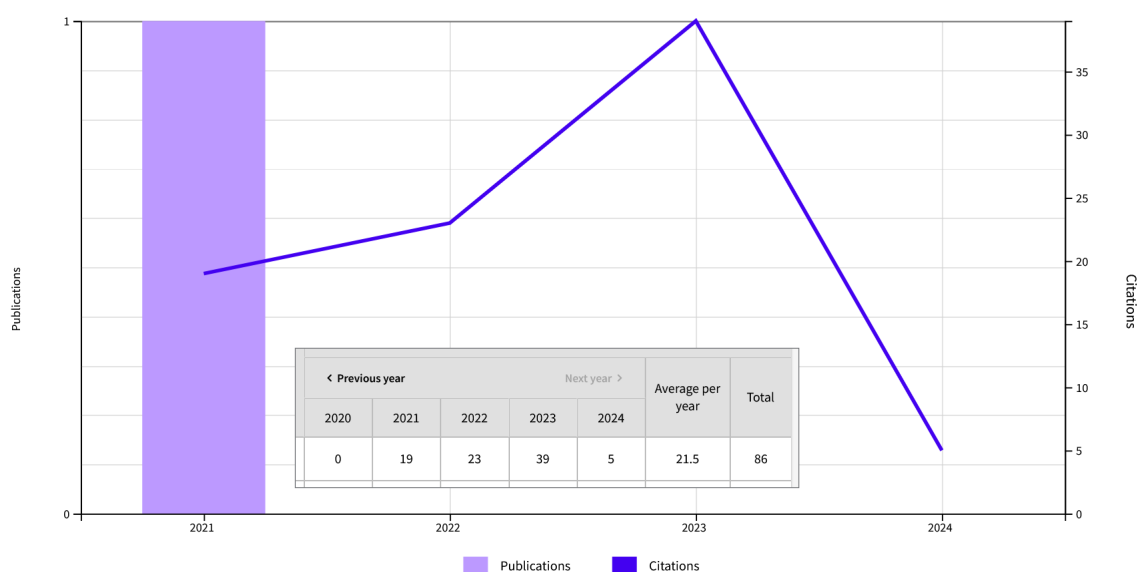

Precup, R.E., David, R.C., Roman, R.C., Petriu, E.M., Szedlak-Stinean, A.I. Slime Mould Algorithm-Based Tuning of Cost-Effective Fuzzy Controllers for Servo Systems, *INTERNATIONAL JOURNAL OF COMPUTATIONAL INTELLIGENCE SYSTEMS*, Volume: 14, Issue: 1, Pages: 1042-1052, ISSN: 1875-6891, eISSN: 1875-6883, 2021;  
Times Cited in Web of Science Core Collection: 86

**Abstract:** This paper suggests five new contributions with respect to the state-of-the-art. First, the optimal tuning of cost-effective fuzzy controllers represented by Takagi-Sugeno-Kang proportional-integral fuzzy controllers (TSK PI-FCs) is carried out using a fresh metaheuristic algorithm, namely the Slime Mould Algorithm (SMA), and a fuzzy controller tuning approach is offered. Second, a relatively easily understandable formulation of SMA is offered. Third, a real-world application of SMA is given, focusing on the optimal tuning of TSK PI-FCs for nonlinear servo systems in terms of optimization problems that target the minimization of discrete-time cost functions defined as the sum of time multiplied by squared control error. Fourth, using the concept of improving the performance of metaheuristic algorithms with information feedback models, proposed by Wang and Tan, Improving metaheuristic algorithms with information feedback models, *IEEE Trans. Cybern.* 49 (2019), 542-555, Gu and Wang,

Improving NSGA-III algorithms with information feedback models for large-scale many-objective optimization, *Fut. Gen. Comput. Syst.* 107 (2020), 49-69, and Zhang et al., Enhancing MOEA/D with information feedback models for large-scale many-objective optimization, *Inf. Sci.* 522 (2020), 1-16, new metaheuristic algorithms are introduced in terms of inserting the model F1 in SMA and other representative algorithms, namely Gravitational Search Algorithm (GSA), Charged System Search (CSS), Grey Wolf Optimizer (GWO) and Whale Optimization Algorithm (WOA). Fifth, the real-time validation of the cost-effective fuzzy controllers and their tuning approach is performed in the framework of angular position control of laboratory servo system. The comparison with other metaheuristic algorithms that solve the same optimization problem for optimal parameter tuning of cost-effective fuzzy controllers suggestively highlights the superiority of SMA. Experimental results are included.

## Web of Science - Clarivate Analytics Highly Cited Paper

As of January/December 2023, this highly cited paper received enough citations to place it in the top 1% of the academic field of **Engineering** based on a highly cited threshold for the field and publication year.

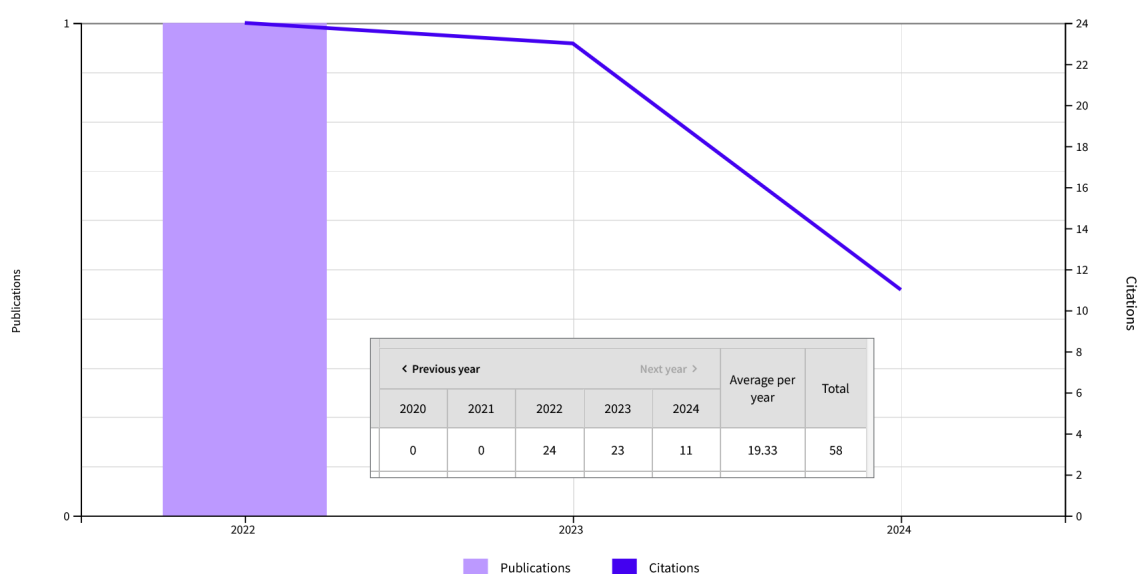

Dar, A.A., Hameed, J., Huo, C.H., Sarfraz, M., Albasher, G., Wang, C.Y., Nawaz, A. Recent optimization and panelizing measures for green energy projects; insights into CO2 emission influencing to circular economy, *FUEL*, Volume: 314, Article Number: 123094, ISSN: 0016-2361, eISSN: 1873-7153, 2022;

Times Cited in Web of Science Core Collection: 58

**Abstract:** Green energy projects (including wind, solar, biomass, hydro projects) are the major constituents of biofuel projects and primary need of global world which are directly concerned with economic growth and gross domestic products (GDP) development. In last few decades, fossil fuel consumption and carbon dioxide (CO2) emission have been increased due to more economic growth and growing population. Moreover, the objective of this research is to assess the consequence of biofuel including natural gas, environmentally friendly power projects (renewable-energy), and thermal power utilization on financial turn of events including GDP and CO2 in ten top countries. Multivariate climate countries with ubiquitous CO2

emission during the period of 1990-2018 were selected to examine the long-run flexibility as well as the path of causality between different variables, the panel co-integration test, panel heterogenous Dumitrescu and Hurlin causality evaluation and panel completely modified ordinary least squares were employed. The panel co-reconciliation test verify that variables have a long-run equilibrium correlation in their relationships. Long haul versatility and causality tests show that natural gas doesn't add to financial development or CO2 decreases. According to this present study, results can help to develop conservative policies regarding long-run and sustainable energy and design in energy development.

## Web of Science - Clarivate Analytics Highly Cited Paper

As of January/December 2023, this highly cited paper received enough citations to place it in the top 1% of the academic field of **Psychiatry/ Psychology** based on a highly cited threshold for the field and publication year.

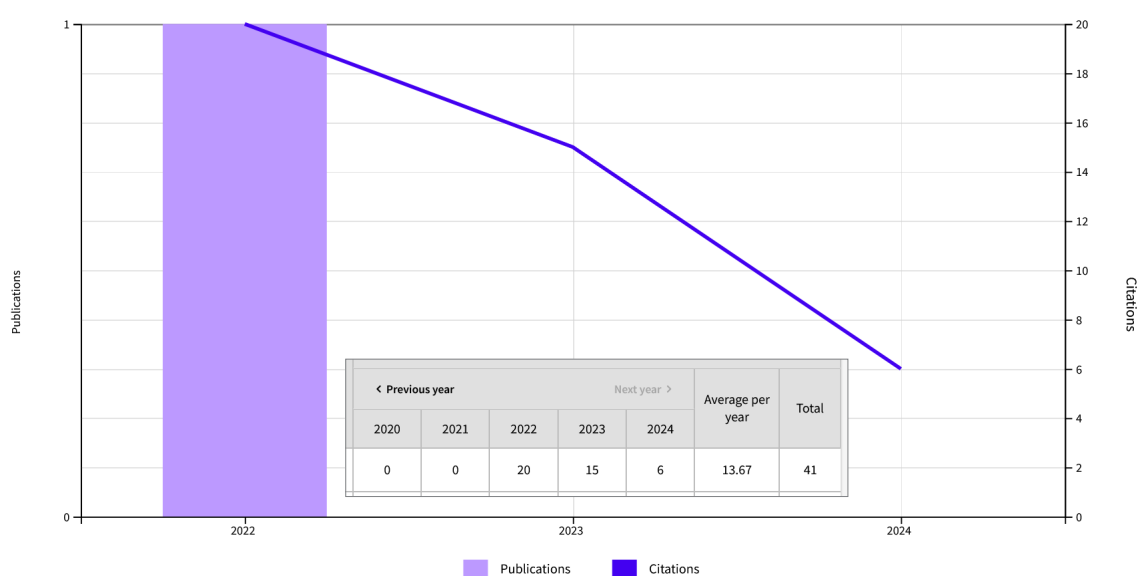

Mohsin, M., Jamil, K., Naseem, S., Sarfraz, M., Ivascu, L. Elongating Nexus Between Workplace Factors and Knowledge Hiding Behavior: Mediating Role of Job Anxiety, *PSYCHOLOGY RESEARCH AND BEHAVIOR MANAGEMENT*, Volume: 15, Pages: 441-457, PubMed ID: 35250318, ISSN: 1179-1578, 2022;  
Times Cited in Web of Science Core Collection: 41

**Abstract:** Purpose: The study objective is to investigate the relationship between workplace ostracism, workplace incivility, and knowledge hiding behavior (evasive hiding, playing dumb, rationalized hiding) while considering the mediating role of job anxiety.

**Methods:** The study collected data through structured questionnaires from 275 participants (ie, employees) working in the small to medium-sized enterprise of five big cities of Pakistan. The study adopted a structured equation modeling technique for data analysis.

**Results:** Significantly, the study results suggest a positive effect of workplace ostracism and workplace incivility on employees' knowledge hiding behavior, and job anxiety significantly mediates the relationship between workplace ostracism, workplace incivility,

and knowledge hiding behavior of employees.

**Conclusion:** The present study highlights the need to examine the personality disposition for understanding the relationship between the variables (eg, workplace ostracism, workplace incivility, knowledge hiding behavior). Employees' inappropriate behavior had suppressed by initiating a campaign for a realistic job preview, setting an exceptional example. The study significantly contributes to the current literature on knowledge hiding behavior by presenting valuable insight into organizational and individual variables, subsequently influencing the knowledge hiding behavior of individuals. Indeed, this study is the first to investigate the predictive effect of the proposed variables.

## Web of Science - Clarivate Analytics Highly Cited Paper

As of November/December 2023, this highly cited paper received enough citations to place it in the top 1% of the academic field of **Engineering** based on a highly cited threshold for the field and publication year.

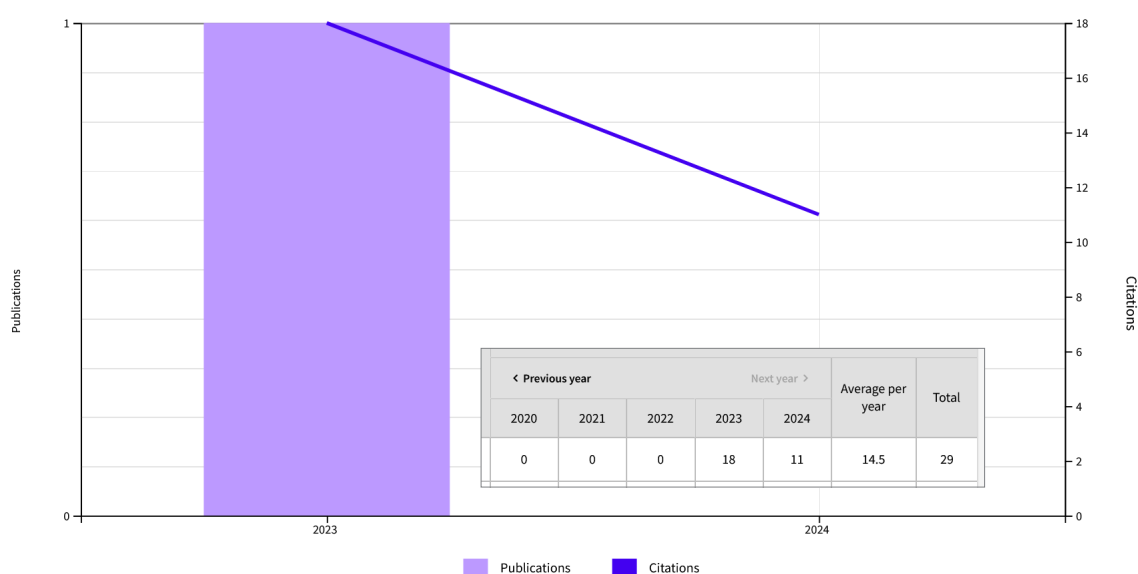

Zamfirache, I.A., Precup, R.E., Roman, R.C., Petriu, E.M. Neural Network-based control using Actor-Critic Reinforcement Learning and Grey Wolf Optimizer with experimental servo system validation, *EXPERT SYSTEMS WITH APPLICATIONS*, Volume: 225, Article Number: 120112, ISSN: 0957-4174, eISSN: 1873-6793, 2023;  
Times Cited in Web of Science Core Collection: 29

**Abstract:** This paper introduces a novel reference tracking control approach implemented using a combination of the Actor-Critic Reinforcement Learning (RL) framework and the Grey Wolf Optimizer (GWO) algorithm. The classical neural network (NN)-based implementation of the Critic, optimized with the Gradient Descent (GD) algorithm, is replaced with the GWO algorithm, aiming to eliminate the main drawbacks of the GD algorithm, i. e., slow convergence and the tendency to get stuck in local optimal values. The combined effort from multiple search agents and the random values involved in the search process make the GWO algorithm very efficient in exploring the solution space and finding global optimal solutions. The main objective of the proposed approach is to build a

NN-based controller capable of solving an optimal reference tracking control problem on nonlinear servo system laboratory equipment. The training data needed to build the controller is collected while the actor learns how to control the servo system, using the GWO-based critic to monitor the process and step in to correct the actor when needed. A comparison study is performed across three online RL-based control approaches, namely the novel approach using GWO to implement the Critic in the Actor-Critic RL framework, the traditional approach using NNs with GD for optimization and another approach using a metaheuristic algorithm called Particle Swarm Optimization (PSO). The experimental results illustrate the superiority of the proposed approach over the competing ones.



## Web of Science - Clarivate Analytics Highly Cited Paper

As of January/April and September/October 2023, this highly cited paper received enough citations to place it in the top 1% of the academic field of **Social Sciences, general** based on a highly cited threshold for the field and publication year.

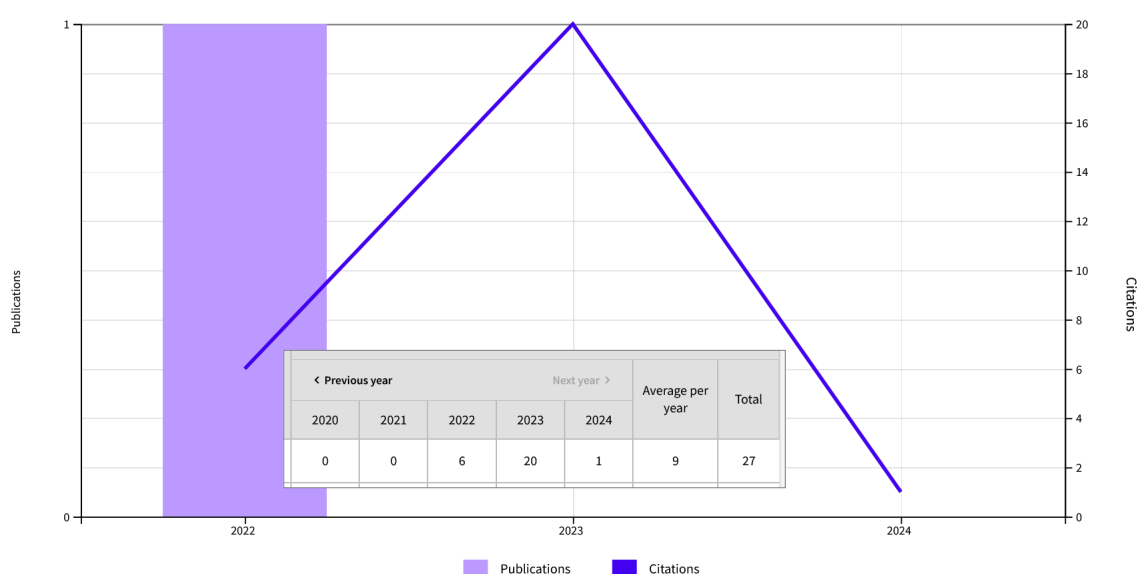

Sarfraz, M., Khawaja, K.F., Ivascu, L. Factors affecting business school students' performance during the COVID-19 pandemic: A moderated and mediated model, *INTERNATIONAL JOURNAL OF MANAGEMENT EDUCATION*, Volume: 20, Issue: 2, Article Number: 100630, ISSN: 0020-0255, eISSN: 1872-6291, 2021;  
Times Cited in Web of Science Core Collection: 27

**Abstract:** The COVID-19 pandemic has directly influenced higher education by converting traditional face-to-face (F2F) learning to blended learning (BL). Because of this dramatic change in the academic environment, it is essential to evaluate student views and preferences and how the BL setting affects their academic performance. Therefore, the current research aims to investigate the relationship between Unified Theory of Acceptance and Use of Technology (UTAUT) constructs (performance expectancy, effort expectancy, and facilitating condition) and student academic performance through

student attitude. We also examined the moderating role of trust in technology between UTAUT constructs and student performance. The study uses a sample of 1050 business management university students for mediation/moderation analysis using the Hayes Bootstrap technique. The results demonstrate that student attitude mediates the relationship between UTAUT constructs and student academic performance, with trust in technology strengthening the relationship. The study offers implications for universities and policymakers.



## BOOKS IN HIGHLIGHT



## LINEAR ELECTRIC MACHINES, DRIVES, AND MAGLEVS HANDBOOK, SECOND EDITION

**Ion BOLDEA**

Published by: CRC Press, 2023

Pages: 736

ISBN: 9781032131030

<https://www.routledge.com/Linear-Electric-Machines-Drives-and-MAGLEVs-Handbook/Boldea/p/book/9781032131030#googlePreviewCont>

### Short description of the context

The Second Edition (First Edition: 2013) of the book is dedicated mainly to R&D and decision-making engineers in industry and to senior undergraduate and graduate students in electric power, mechanical, robotics, power electronics and control engineering. It is based mainly on the author's vast experience in the field (40 years), which includes five books in English published in 1976, 1985, 1987, 1996 and 2001, but also draws heavily from recent contributions to the field worldwide.

### Purpose and Motivation of the book

The numerous numerical design and control examples (with practical specifications) throughout the 23 chapters of the book allow the reader deep and fast access to a practical but thorough unitary (good for comparisons) methodology in designing and controlling LEMs for various applications.

### Summary

The book is structured into 23 chapters:

- Fields, Forces, and Materials for LEMs;
- Classifications and Applications of LEMs;
- Linear Induction Motors: Topologies, Fields, Forces, and Powers Including Edge, End, and Skin Effects;
- Linear Induction Motors: Theories, Transients, and Control;
- Design of Flat and Tubular Low-Speed LIMs;
- Transportation (Medium- and High-Speed) SLIM Design;
- DC-Excited Linear Synchronous Motors (DCE-LSM) Steady State, Design, Transients, and Control;
- Superconducting Magnet Linear Synchronous Motors;
- Homopolar Linear Synchronous Motors (H-LSM): Modeling, Design, and Control;
- Linear Reluctance Synchronous Motors: Modeling, Performance Design, and Control;
- Linear Switched Reluctance Motors (L-SRM): Modeling, Design, and Control;
- Flat Linear Permanent Magnet Synchronous Motors;

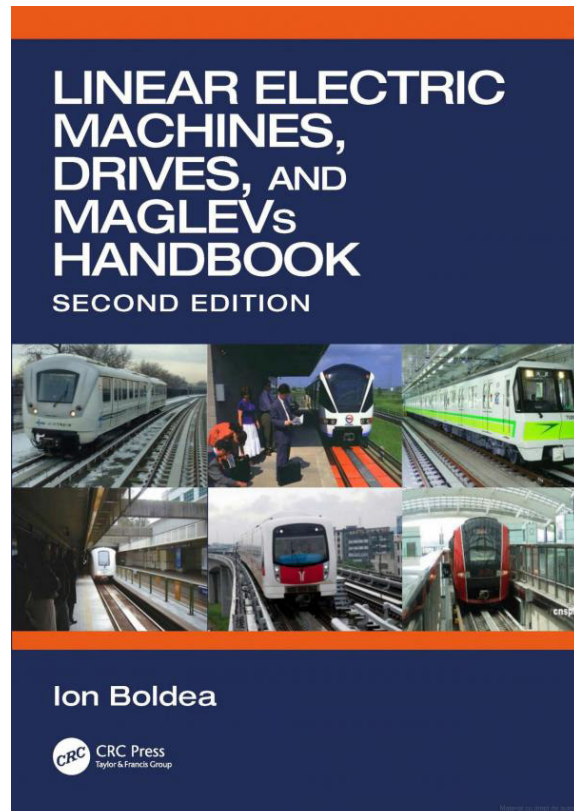

- Tubular Linear Permanent Magnet Synchronous Motors;
- Multi-Pole Coil Three- or Two-Phase Linear PM Reluctance Motors;
- Flux- Modulation Linear PM Motors and Magnetic Screws;
- Plunger Solenoids and Their Control;
- Linear Single-Phase PM Brushless Motors;
- Resonant Linear Oscillatory Single-Phase PM Motors/Generators;
- Multiaxis Linear PM Motor Drives;
- Attraction Force (Electromagnetic) Levitation Systems;
- Repulsive Force Levitation Systems;
- Active Guideway MAGLEVs;
- Passive Guideway MAGLEVs



## A MULTILINGUAL DICTIONARY OF TRANSLATION AND INTERPRETING: ENGLISH – GERMAN – ROMANIAN

Simona ȘIMON, Marcela Alina FĂRCAȘIU, Anca DEJICA-CARȚIȘ, Daniel DEJICA

Published by: Pro Universitaria, Bucharest, 2023

Pages: 273

ISBN: 978-606-26-1790-5

### Short description of the context

In a globalized world, mastering foreign languages and acquiring translation and interpreting skills are a goal that has to be met by the education system as well as by today's multicultural and multilingual communities in an endeavor to create an inclusive and dynamic society in which personal and professional exchanges are not hindered by linguistic and cultural differences. As such, knowing the terminology used in the field of translation and interpreting is the first step made in this direction by anyone wishing to build a career in the field of translation, interpreting, linguistics, language teaching or/and communication.

### Purpose and Motivation of the book

A MULTILINGUAL DICTIONARY OF TRANSLATION AND INTERPRETING: ENGLISH — GERMAN — ROMANIAN is the first multilingual dictionary of this type both in Romania and abroad, at least to the authors' knowledge. The dictionary comprises semi-specialized and specialized vocabulary, being a useful tool for translators, interpreters, communication specialists, academics and students, and for the general public, who is interested in learning field-specific concepts in English, German and Romanian.

### Summary

A MULTILINGUAL DICTIONARY OF TRANSLATION AND INTERPRETING: ENGLISH — GERMAN — ROMANIAN focuses mainly on the field of translation and interpreting, but it also addresses related fields, namely linguistics, communication, education, language industry, translation technology and management.

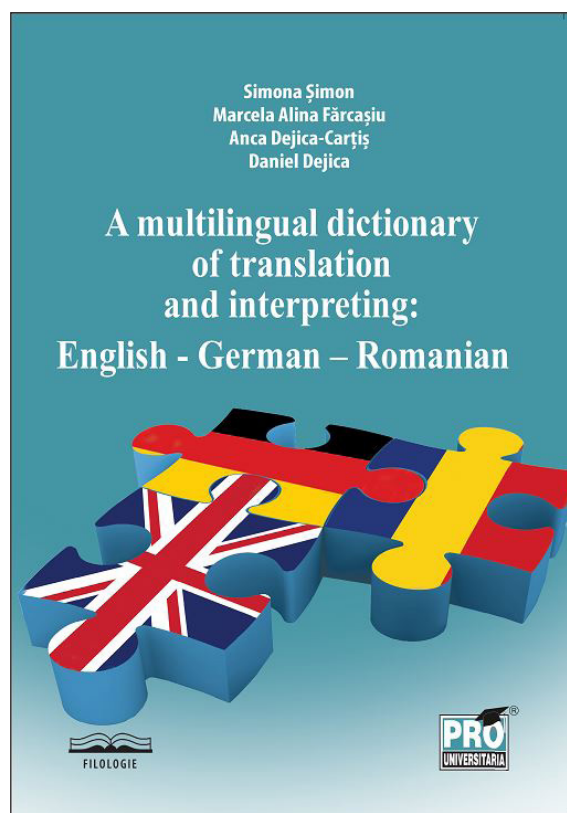

- The dictionary includes more than 3,000 terms and phrases, selected on frequency and usage criteria.
- The dictionary contains three trilingual annexes, covering types of official documents that are usually sworn-translated, national and international associations and institutions in the field of translation and interpreting as well as national and international standards in this field.
- The book ends with three indices of the main English, German, and Romanian keywords as well as with the bibliography and webography used to create this dictionary.

Marius GHEJU

Published by: Politehnica Publishing, 2023

Pages: 304

ISBN: 978-606-35-0518-8

### Short description of the context

This work is aimed at students, teachers, engineers, and researchers who are engaged in environmental engineering.

### Purpose and Motivation of the book

- Along with water and soil, the atmosphere is a crucial component of the environment, indispensable for life on Earth.
- This comprehensive work serves as a critical resource for anyone seeking to deepen their understanding of this field.

### Summary

- The topic of this work addresses the field of environmental chemistry. The book is structured in 14 chapters, illustrated with figures and tables.
- In the first 2 chapters, general topics are treated, including the composition, structure, stability / instability of the atmosphere. Subsequently, important chemical species existing in the atmosphere are discussed in separate chapters, as well as processes in which they can be involved.
- In the last 3 chapters, aspects regarding a series of complex atmospheric pollution phenomena are presented, such as acid rain, global warming, smog.

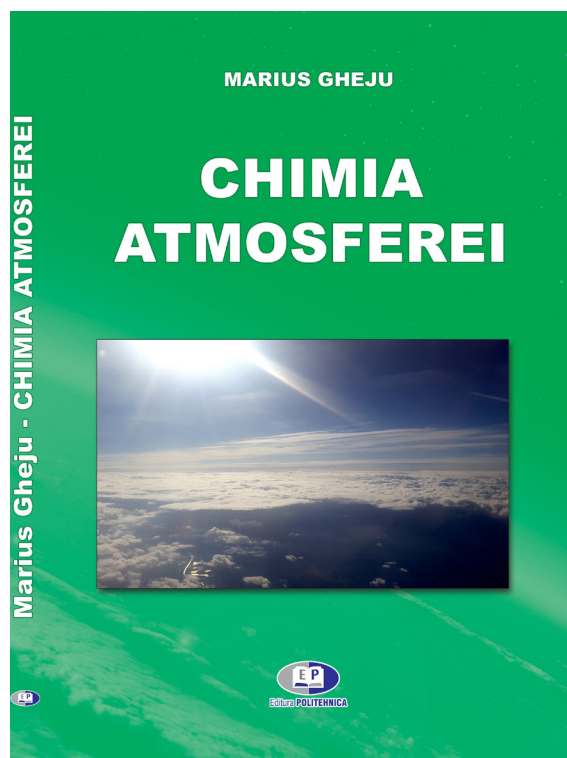



# BOOKS LIST



1. Anghel, A.A., Zăbavă, E.S. Modelare 3D avansată și fabricație digitală, Editura Politehnica, Timișoara, 2023, ISBN 978-606-35-0542-3;
2. Boldea, I. Linear Electric Machines, Drives, and MAGLEVs Handbook, Second Edition, CRC Press, 2023, ISBN: 9781032131030;
3. Bompa, T.O., Sărăndan S.O. Pregătire fizică pentru fotbal. Știința și metodologia, Editura Politehnica, Timișoara, 2023, ISBN 978-606-35-0545-4;
4. Brighenti, R., Marșavina, L., Sedmak, A., Nahlik, L., Berto F. (Ed) International Conference. Structural Integrity and Reliability of Advanced Materials obtained through Additive Manufacturing, Editura Politehnica, Timișoara, 2023, ISBN 978-606-35-0525-6;
5. Cosma, C. Tehnologii de prototipare și fabricație rapidă, Editura Politehnica, Timișoara, 2023, ISBN 978-606-35-0548-5;
6. Deaconu, S.I., Blaj, M.A. Mașini și acționări electrice în industria autovehiculelor rutiere, Editura Politehnica, Timișoara, 2023, ISBN 978-606-35-0523-2;
7. Deaconu, S.I., Topor, M. Mașini și acționări electrice în automatizări industriale, Editura Politehnica, Timișoara, 2023, ISBN 978-606-35-0524-9;
8. Dejica, D., Dragomir, G.M. Dicționar englez-român, român-englez cu termeni și expresii utilizate în domeniul egalității de șanse și tratament. Ediția a III-a revizuită și adăugită, Editura Politehnica, Timișoara, 2023, ISBN 978-606-35-0560-7;
9. Eugeni, C., Gambier, Y. La traduction intralinguistique les défis de la diamesie, Editura Politehnica, Timișoara, 2023, ISBN 978-606-35-0517-1;
10. Feier, A., Popescu, M., Magda A. 70 de ani de ingineria sudării la Universitatea Politehnica Timișoara. Monografie, Editura Politehnica, Timișoara, 2023, ISBN 978-606-35-0532-4;
11. Frigură-Iliasa, M., Guțu-Chetrușca, C. Impactul instalațiilor energetice asupra mediului. Aplicații, Editura Politehnica, Timișoara, 2023, ISBN 978-606-35-0544-7;
12. Ghangrekar, M.M. (Editor), Surampalli, R.Y. (Editor), Zhang, T.C. (Editor), Duteanu, N.M. (Editor). Microbial Electrochemical Technologies: Fundamentals and Applications, Volumes 1 & 2, Wiley - VCH, 2023, ISBN: 978-352783900-1, 978-352735372-9;
13. Gheju, M. Chimia atmosferei, Editura Politehnica, Timișoara, 2023, ISBN 978-606-35-0518-8;
14. Grosseck, M.D. Die terminologielehre leicht Verständlich, Editura Politehnica, Timișoara, 2023, ISBN 978-606-35-0522-2;
15. Gubencu, D.V. Îmbunătățirea continuă a proceselor tehnologice, Editura Politehnica, Timișoara, 2023, ISBN 978-606-35-0490-7;
16. Gubencu, D.V. Tolerarea și măsurarea mărimilor geometrice, Editura Politehnica, Timișoara, 2023, ISBN 978-606-35-0551-5;
17. Hălbac-Cotoară-Zamfir, C., Rădulescu, R., Hălbac-Cotoară-Zamfir, R. Expoziția culturii banațene, Editura Politehnica, Timișoara, 2023, ISBN 978-606-35-0568-3;
18. Hălbac-Cotoară-Zamfir, R., Hălbac-Cotoară Zamfir, C., Mușat, C.C., Sîrbu, I.V., Barstad, J., Evans, R. Patrimoniul cultural urban, Editura Politehnica, Timișoara, 2023, ISBN 978-606-35-0559-1;

19. Hălăbac-Cotoară-Zamfir, R., Hălăbac-Cotoară-Zamfir, C., Iacobescu, O.J., Sirbu, I., Bertolin, C., Ogut, O., Bonnevie Cyvin, J., Stolte, J., Krzeminska, D. Cultura parcurilor – parcuri ale culturii, Editura Politehnica, Timișoara, 2023, ISBN 978-606-35-0550-8;
20. Hălăbac-Cotoară-Zamfir, R., Hălăbac-Cotoară-Zamfir, C., Văduva, R., Povian, C.M., Anghel, A.A., Stolte, J., Fennell, J., Barstad, J., Evans, R. Gândește verde. Cetățenia de mediu, Editura Politehnica, Timișoara, 2023, ISBN 978-606-35-0564-5;
21. Hălăbac-Cotoară-Zamfir, R., Toma, R.A., Ilin, C.M., Cernicova-Bucă, M., Evans, R., Gudiu, C., Hălăbac-Cotoară-Zamfir, C., Barstad, J. Împuternicirea tinerilor cetățeni ca viitori creatori și furnizori ai culturii tehnice urbane, Editura Politehnica, Timișoara, 2023, ISBN 978-606-35-0562-1;
22. Hălăbac-Cotoară-Zamfir, R., Toma, R.A., Ilin, C.M., Cernicova-Bucă, M., Evans, R., Gudiu, C., Hălăbac-Cotoară-Zamfir, C., Barstad, J. Împuternicirea tinerilor cetățeni ca viitori creatori și furnizori ai culturii tehnice urbane, Editura Politehnica, Timișoara, 2023, ISBN 978-606-35-0562-1;
23. Manea, A.S., Stroitiță, D.C. Hidraulică și mașini hidraulice, Editura Politehnica, Timișoara, 2023, ISBN 978-606-35-0515-7;
24. Mateaș, M. Experimentarea roboților, Editura Politehnica, Timișoara, 2023, ISBN 978-606-35-0521-8;
25. Mateaș, M. Tehnici și sisteme de măsurare în medicină, Editura Politehnica, Timișoara, 2023, ISBN 978-606-35-0515-7;
26. Mihăilescu, B., Wohlrabe, H., Blecha, T., Gontean, A. (Ed) ISSE 2023. 46<sup>th</sup> International Spring Seminar on Electronics Technology „Revolutionizing the electronics Ecosystems – Chiplet and Heterogeneous Integration”, Editura Politehnica, Timișoara, 2023, ISBN 978-606-35-0528-7;
27. Mircea, V.Ș. Bastioane ale ingineriei civile, Editura Politehnica, Timișoara, 2023, ISBN 978-606-35-0512-6;
28. Moza, G. Differential and integral calculus, Editura Politehnica, Timișoara, 2023, ISBN 978-606-35-0558-4;
29. Muzi, M., Botha, N., Schick, B., Simionescu, O. (Ed) Bright Cityscapes, Editura Politehnica, Timișoara, 2023, ISBN 978-606-35-05555-3;
30. Osaci, M. Fizică. Teme experimentale, Editura Politehnica, Timișoara, 2023, ISBN 978-606-35-0530-0;
31. Osaci, M. Fizică. Teorie și aplicații, Editura Politehnica, Timișoara, 2023, ISBN 978-606-35-0529-4;
32. Păunescu, D., Negrea, R., Cădăriu, L., Moza, G., Jivulescu, M., Bînzar, T., Arieșanu, C., Lăzureanu, C., Gîrban, A., Bundău, O., Juratoni, A., Hedrea, C., Petrișor, C., Eckstein, A., Lupa, N., Cismaș, E. Culgere de probleme de matematică pentru examenul de admitere din anul 2024 la Universitatea Politehnica Timișoara, Editura Politehnica, Timișoara, 2023, ISBN 978-606-35-0565-2;
33. Perju, D., Mateaș, M. Tehnici și sisteme de măsurare, Editura Politehnica, Timișoara, 2023, ISBN 978-606-35-0516-4;
34. Proștean, G., Giuca, O., Suru, S.N. Inginerie industrială și management. Aplicații, Editura Politehnica, Timișoara, 2023, ISBN 978-606-35-0539-3;
35. Rațiu, S. Internal combustion engines for road vehicles. Construction and calculation. Practical approach, Editura Politehnica, Timișoara, 2023, ISBN 978-606-35-0553-9;
36. Rusu, L.M. Informatică aplicată – online, Editura Politehnica, Timișoara, 2023, ISBN 978-606-35-0535-5;

37. Rusu, L.M. Programare în Matlab – online, Editura Politehnica, Timișoara, 2023, ISBN 978-606-35-0520-1;
38. Rusu, L.M. Tehnici și echipamente pentru imagistică medicală – online, Editura Politehnica, Timișoara, 2023, ISBN 978-606-35-0537-9;
39. Stroiță, C.D., Ghera, C. Acționări hidraulice, Editura Politehnica, Timișoara, 2023, ISBN 978-606-35-0554-6;
40. Stroiță, C.D., Ghera, C., Manea, A.S. Acționări hidraulice și pneumatice. Aplicații, Editura Politehnica, Timișoara, 2023, ISBN 978-606-35-0543-0;
41. Șelariu, M. Supermatematica. Fundamente. Vol. 3, Editura Politehnica, Timișoara, 2023, ISBN 978-606-35-0540-9;
42. Șelariu, M. Supermatematica. Fundamente. Vol. 4, Editura Politehnica, Timișoara, 2023, ISBN 978-606-35-0541-6;
43. Șimon, S., Fărcașiu, M. A., Dejica-Cartîș, A., Dejica, D. A Multilingual Dictionary of Translation and Interpreting: English – German – Romanian, Pro Universitaria, București, 2023, ISBN: 978-606-26-1790-5;
44. Ternauciu, A. Sisteme de gestiune a conținutului WEB. Platforme online construite cu Joomla, Editura Politehnica, Timișoara, 2023, ISBN 978-606-35-0556-0;
45. Tutelea, N.L., Deaconu, S.I., Muntean, N., Feifei, B., Topor, M. Generatorul asincron cu două înfășurări statorice de putere și turație redusă, Editura Politehnica, Timișoara, 2023, ISBN 978-606-35-0557-7;
46. Universitatea Politehnica Timișoara. Facultatea de Mecanică, Laboratorul de Rezistența Materialelor. Un secol de activitate. 1923 – 2023, Editura Politehnica, Timișoara, 2023, ISBN 978-606-35-0547-8;
47. Vilceanu, C.B., Herban, I.S., Chendeș, R.V. Aplicații ale tehnologiilor avansate de măsurare în domeniul geodeziei, Editura Politehnica, Timișoara, 2023, ISBN 978-606-35-0566-8;
48. Zaharia, R., Both, I., Duma D. Structural analysis. Statically indeterminate structures – theory, Editura Politehnica, Timișoara, 2023, ISBN 978-606-35-0507-2;
49. Zăbavă, E. S., Sălcianu, C.L., Pașca M.A. Pași de modelare în CAD. Aplicații în CATIA V5, Editura Politehnica, Timișoara, 2023, ISBN 978-606-35-0534-8.

